

ML6425, ML7425 Spring Return Electric Linear Valve Actuators

PRODUCT DATA



FEATURES

ML6425 and ML7425

- Accurate valve positioning.
- Quick and easy installation.
- No separate linkage required.
- On power failure:
ML6425A and ML7425A drive valve stem down.
ML6425B and ML7425B draw valve stem up.
- Conduit connector is standard.
- No adjustments required.
- True spring return on power failure.
- Low power consumption.
- High close-off ratings.
- Force-limiting end switches.
- Direct/reverse action.
- Synchronous motor.
- Corrosion resistant design.
- Maintenance free.

ML7425

- Position Feedback signal.
- Fail-safe position selection for control signal loss.

APPLICATION

The ML6425 Spring Return Electric Linear Valve Actuators are floating control actuators used with controllers that provide a switched or floating single-pole double-throw (spdt) output. These actuators operate standard Honeywell valves in heating, ventilating, and air conditioning (HVAC) applications.

The ML7425 Spring Return Electric Linear Valve Actuators are modulating control actuators used with controllers that provide an analog output of 0 to 10 Vdc or 2 to 10 Vdc. These actuators operate standard Honeywell valves in heating, ventilating, and air conditioning (HVAC) applications. An internal selector plug can be used to reverse the direction of action.

Contents

Application	1
Features	1
Specifications	2
Ordering Information	2
Installation	3
Operation	7
Checkout	8



SPECIFICATIONS

Models:

Model	Spring Return Action	Description
ML6425A	Drive valve stem down on power failure	Electric Linear Valve Actuator
ML7425A		
ML6425B	Draw valve stem up on power failure	
ML7425B		

Dimensions: See Fig. 1.

Weight: 5.1 lb (2.3 kg).

Electrical Ratings:

Power Input: 24 Vac \pm 15%, 60 Hz.

Power Consumption:

ML6425: 11 VA maximum at 24 Vac.

ML7425: 12 VA maximum at 24 Vac.

Signal Source Output Resistance: 1 kOhm maximum.

Signal Load: 1 mA maximum.

Signal Inputs (Supply Voltage Between Terminals):

ML6425:

B and 24 Vac: Drive valve stem down.

W and 24 Vac: Draw valve stem up.

ML7425: 0 to 10 Vdc or 2 to 10 Vdc.

Stem Force: 135 lbf (600N).

Actuator Stroke: 3/4 in. (20 mm).

Actuator Run Time at 60 Hz: 90 seconds.

Spring Return Time: 12 seconds.

Temperature Ranges:

Ambient: 14°F to 122°F (-10°C to +50°C).

Storage: -40°F to +158°F (-40°C to +70°C).

Maximum Valve Medium: 300°F (150°C).

Humidity: 5 to 95 percent relative humidity, noncondensing.

Close-off Pressure Ratings: See Table 1.

Protection Standard: IP54.

Approvals:

Underwriter's Laboratories, Inc. UL94-5V Flame Retardant.

Meets CE requirements.

Cable entry: Conduit connector and one knockout on case.

Actuator Material:

Cover: ABS-FR plastic.

Base: PBTP-FR plastic.

Yoke: Diecast aluminum.

Accessories:

43191679-111 Single Auxiliary 10K ohm Potentiometer.

43191679-112 Single Auxiliary 220 ohm Potentiometer.

43191680-105 Dual Auxiliary Switch (for 24 Vac use *only*).

43196000-001 High Temperature Kit (1/2 to 3 in. valves).

Increases temperature range high-end to 428°F (220°C).

ORDERING INFORMATION

When purchasing replacement and modernization products from your TRADELINE® wholesaler or distributor, refer to the TRADELINE® Catalog or price sheets for complete ordering number.

If you have additional questions, need further information, or would like to comment on our products or services, please write or phone:

1. Your local Home and Building Control Sales Office (check white pages of your phone directory).
2. Home and Building Control Customer Logistics
Honeywell Inc., 1885 Douglas Drive North
Minneapolis, Minnesota 55422-4386 (612) 951-1000

In Canada—Honeywell Limited/Honeywell Limitée, 155 Gordon Baker Road, North York, Ontario M2H 3N7.

International Sales and Service Offices in all principal cities of the world. Manufacturing in Australia, Canada, Finland, France, Germany, Japan, Mexico, Netherlands, Spain, Taiwan, United Kingdom, U.S.A.

Table 1. Close-off ratings for ML6425, ML7425 Electric Linear Valve Actuators and Honeywell Valves (psi).

Type	Valve	1/2 in.	3/4 in.	1 in.	1-1/4 in.	1-1/2 in.	2 in.	2-1/2 in.	3 in.
Flange	V5011A	—	—	—	—	—	—	28	16
	V3350/3351/3450/3451	—	—	—	—	—	—	21	14
	V5013B,C; V3360/3361/3460/3461	—	—	—	—	—	—	21 ^a	14 ^a
NPT	V5011F,G	150 ^b	150 ^b	150 ^b	134 ^b	77	49	28	16
	V5011H,J	150	150	150	145	—	—	—	—
	V5011N1xxx, V5011N3xxx, V5013N	230	230	163	104	67	37	—	—
	V5011N2xxx	100	100	100	100	67	37	—	—
	V5013F	150	150	150	126	77	49	—	—

^aRepresents maximum pressure difference between the outlet and either of the two inlets.

^bDo not exceed 100 psi with V5011G valves used in steam applications.

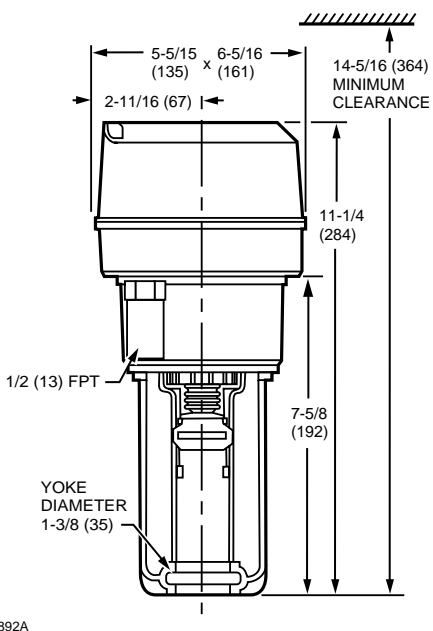

Fig. 1. Approximate dimensions of ML6425, ML7425 Electric Linear Valve Actuator in in. (mm).

INSTALLATION

When Installing this Product...

1. Read instructions carefully. Failure to follow them could damage the product or cause a hazardous condition.
2. Check ratings and description given in the specifications to make sure the product is suitable for your application.
3. Installer must be a trained, experienced service technician.
4. After installation is complete, check out product operation as provided in these instructions.



CAUTION

Electrical Shock or Equipment Damage Hazard.
Can shock individuals or short equipment circuitry.
 Disconnect power supply before installation.

Location

Install the actuator in a location that allows enough clearance for mounting accessories and for servicing.



CAUTION

Equipment Damage Hazard.
Can damage actuator due to condensation or a valve gland leak.
 Install the actuator in a position above horizontal.

Mounting

1. Place the actuator on the valve with the U-bolt around the valve collar. See Fig. 2.
2. Place the U-bolt against the valve collar and secure the actuator to the valve by turning each U-bolt nut clockwise. To assure even pressure on the collar, first tighten the nuts finger-tight and then alternate turning each U-bolt nut until both are snug.
3. Push aside the stem button retaining clip and hold. See Fig. 3.
4. Lift valve stem until the head of the valve stem button is inside the large slot of the stem button retaining clip on the actuator.
5. Release the stem button retaining clip to secure the stem button. Check to make certain the stem button is secured by the retaining clip.
6. Remove the cover from the actuator using a Phillips or crosspoint screwdriver. See Fig. 4.



CAUTION

Personal Injury Hazard.
Manual spring handle under tension can turn quickly when lifted, pinching fingers between handle and plastic casing.
 Use a screwdriver to lift and release manual spring handle. (See Fig. 5.)

7. Remove the manual spring handle retaining clip, and lift and release the handle. See Fig. 5. The easiest way to perform this operation safely is to:
 - a. Remove the retaining clip.
 - b. Wedge a small, flat-bladed screwdriver under the manual spring handle and pry up the handle. (See Fig. 5.)

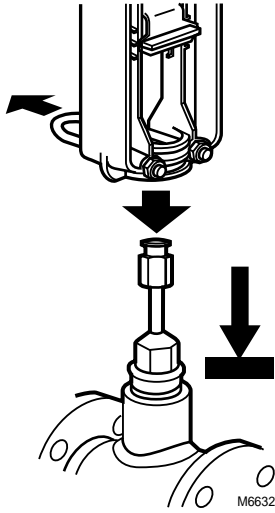

Fig. 2. Attaching actuator to valve collar.

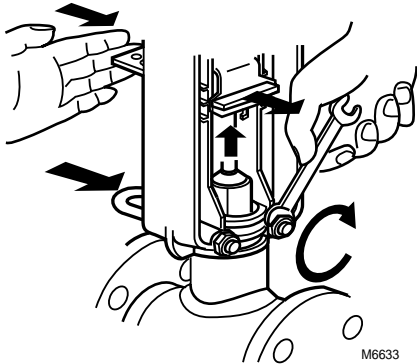

Fig. 3. Securing actuator to valve.

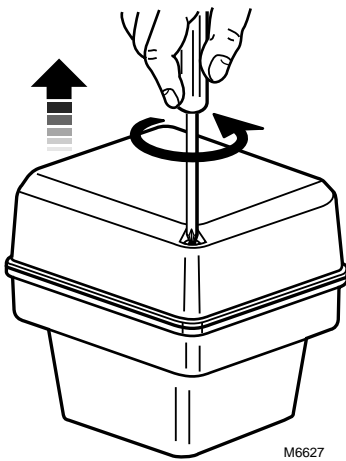

Fig. 4. Removing actuator cover.

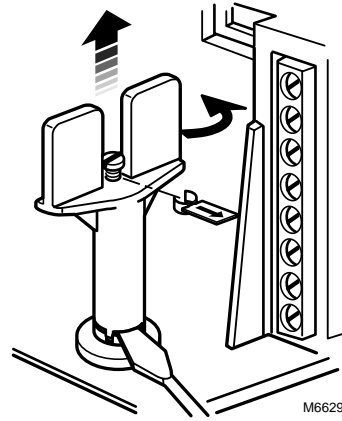

Fig. 5. Removing spring retaining clip and releasing manual spring handle.

Wiring



CAUTION

Electrical Shock or Equipment Damage Hazard.
Can shock individuals or short equipment circuitry.
Disconnect power supply before installation.

All wiring must comply with local electrical codes, ordinances and regulations. Voltage and frequency of the transformer used with the actuator must correspond with the power supply and actuator characteristics. See Fig. 6 through 13 for connection information and typical wiring hookups.

1. Feed power and control wires through the conduit connector located on the bottom of the actuator case. See Fig. 6.



CAUTION

Equipment Damage Hazard.
Conduit connection or removal can break an unsupported connector.
When removing or attaching conduit, use a wrench to support the motor connector.

2. Using the wiring diagram in Fig. 7, connect power and control wires. Make sure that all wiring is correct.
3. When wiring is complete, replace the cover on the actuator. See Fig. 14.
4. Apply power and control signals to the actuator.

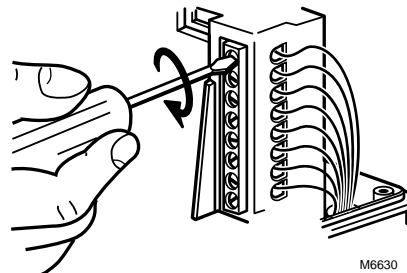

Fig. 6. Connecting power and control wiring.

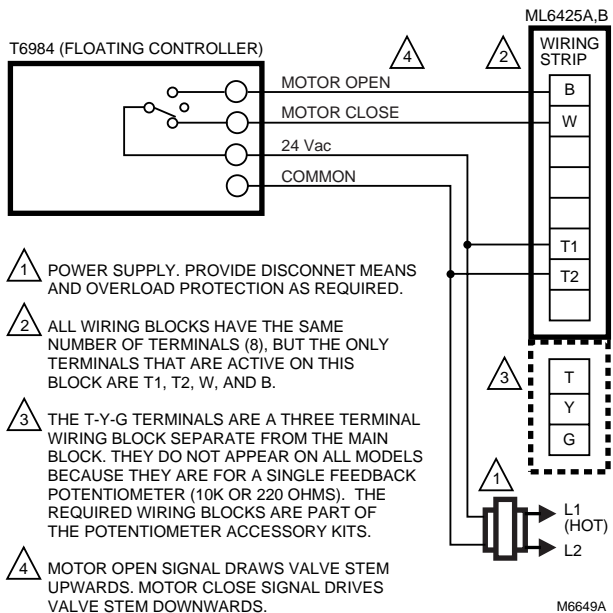

Fig. 7. ML6425 wiring.

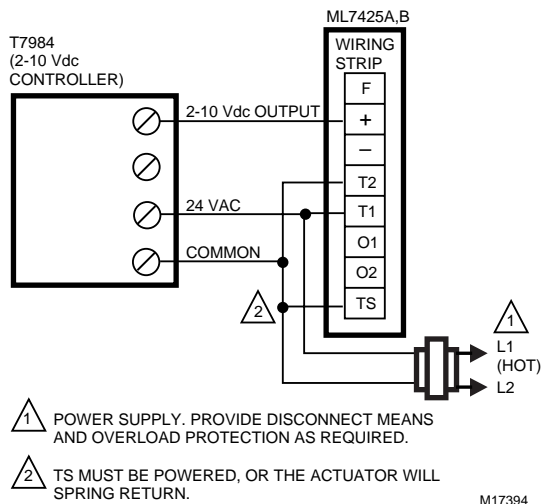

Fig. 8. ML7425 wiring.

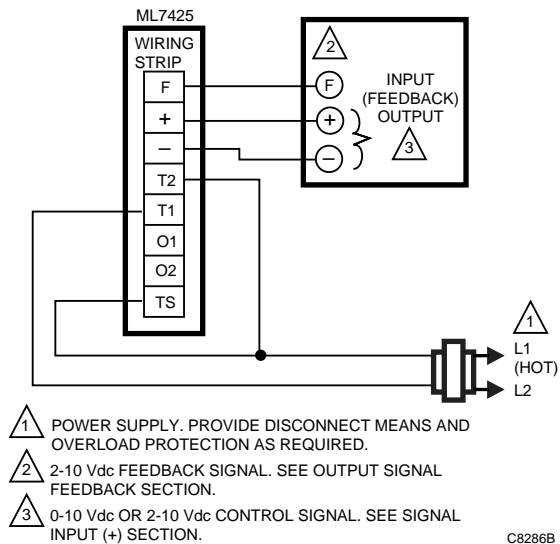

Fig. 9. ML7425 wiring using controller feedback output and a common transformer.

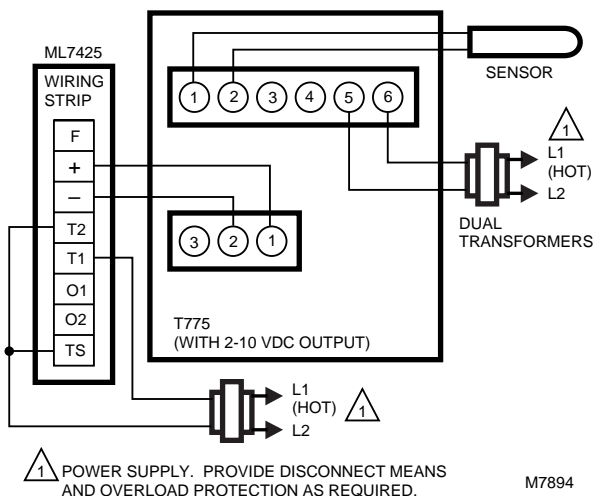

Fig. 10. ML7425 wiring using 2 to 10 Vdc control signal and separate transformers.

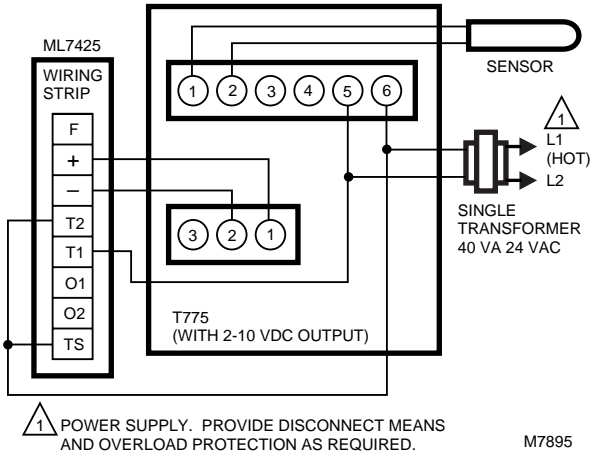

Fig. 11. ML7425 wiring using 2 to 10 Vdc control signal and a common transformer.

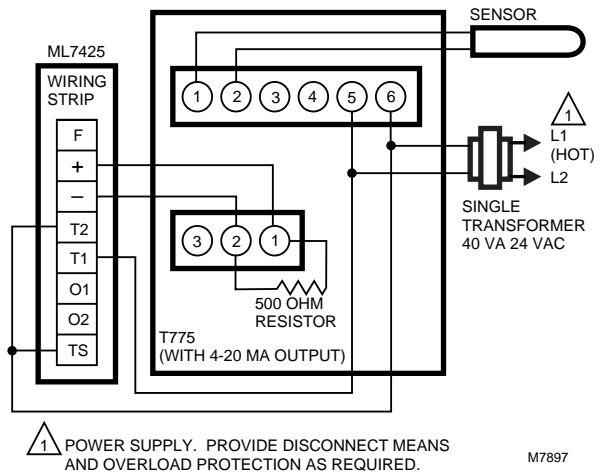

Fig. 13. ML7425 wiring using 4 to 20 mA control signal and a common transformer.

NOTE: 500 ohm resistor not shipped with product.

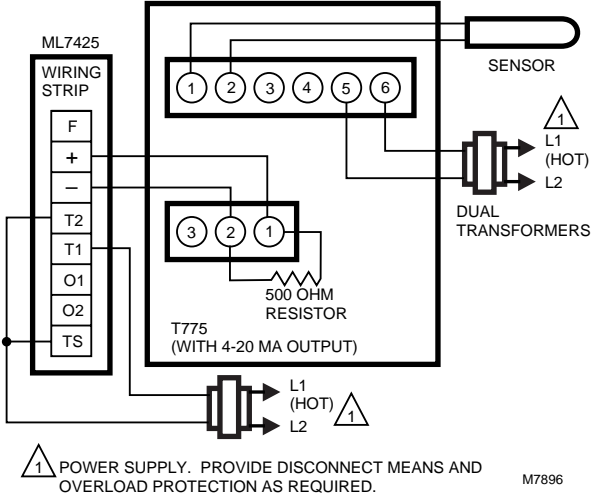

Fig. 12. ML7425 wiring using 4 to 20 mA control signal and separate transformers.

NOTE: 500 ohm resistor not shipped with product.

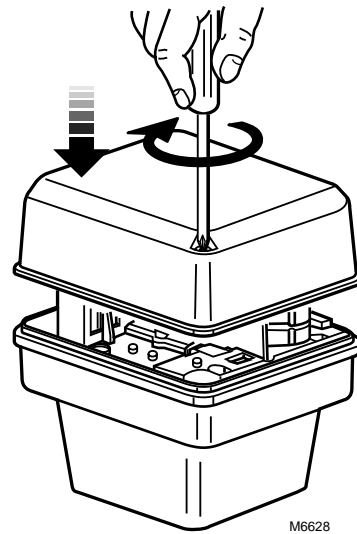

Fig. 14. Replacing actuator cover.

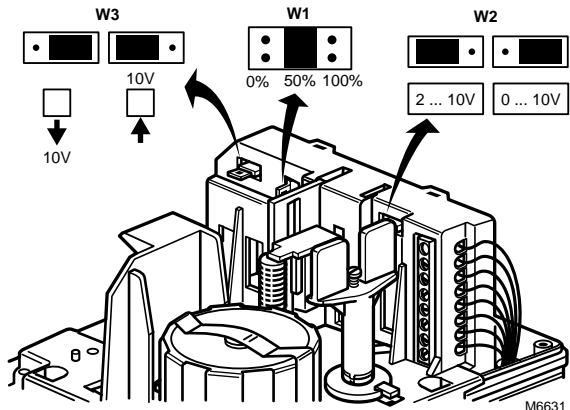

Fig. 15. Location of W1, W2, and W3 selector plugs.

Auxiliary Potentiometers

The 43191679 Auxiliary Potentiometers can be used as feedback potentiometers and to provide remote indication of the valve position. See the Installation Instructions packed with the potentiometers.

Auxiliary Switches



CAUTION

Equipment Damage Hazard.

Improper voltage will damage the auxiliary switch beyond repair.

Use the 43191680 Dual Auxiliary Switch only with 24 Vac applications.

The 43191680 Dual Auxiliary Switch can be used on both the ML6425 and ML7425 Electric Linear Valve Actuators. Switching points are adjustable over the full length of actuator stroke; for example, the switch can be used to switch pumps or provide remote indication of any stroke position. See the Installation Instructions packed with the auxiliary switch.

OPERATION

In the actuator, the drive of a synchronous motor is converted into the linear motion of the actuator stem by using a spur gear transmission. A button retainer clip connects the actuator stem to the valve stem.

An integrated spring package limits the stem force to a factory-adjusted value in either direction. Installed microswitches turn off the actuator when the specified stem force is reached.

The ML6425, ML7425 Spring Return Valve Actuators provide a safety valve position in the event of power failure. On power failure, the ML6425A and ML7425A extend the actuator stem; the ML6425B and ML7425B retract the actuator stem.

The actuators are shipped from the factory with a spring handle retaining clip installed, so the actuator can be connected to the valve without applying power. Remove this clip after the actuator is installed. (See Installation section.)

ML7425

Signal Input (+)

The analog input signal (+) range is set at the factory to 0 to 10 Vdc. Changing the position of the W2 selector plug sets the range to 2 through 10 Vdc. Selector plugs W1, W2, and W3 are positioned on the back side of the printed circuit board. See Fig. 15 for location of the selector plugs.

Signal Input Failure

Using selector plug W1, the actuator can be set to run to one of three positions in event of a signal failure:

- 0% Actuator position corresponds with 0 or 2 Vdc signal.
- 50% Actuator stem in mid-position.
- 100% Actuator position according to 10 Vdc signal.

NOTE: W1 is factory set at the mid-position.

Output Signal Feedback (F)

An analog output signal (2 to 10 Vdc) that represents the actual actuator stem position is available at terminal F. It can be used for remote indication of the stem position. When the valve stem is fully downward, the output signal is 10 Vdc.

When the valve stem is up, the output signal is 0 or 2 Vdc. The output of the signal does not change when the action of the actuator is reversed using W3. See Direction of Action.

Actuator Override

To override the control signal (for freeze protection or similar applications), connect the 24 Vac common (T2) to either terminal O1 or O2. Connecting to terminal O1 fully extends the actuator stem. Connecting to O2 fully retracts the actuator stem.

The control signal (+) is ignored when the override signal is applied to Terminal O1 or O2. This override can be achieved with a switch or a relay. See Fig. 16.

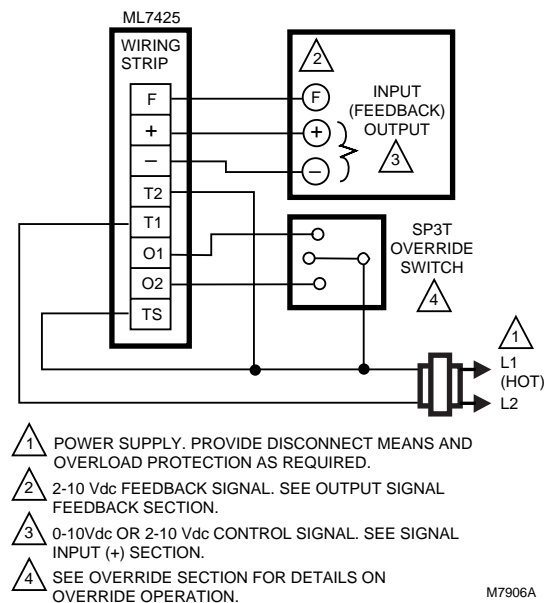

Fig. 16. Connections for overriding control signal to drive ML7425 to a specific position.

Direction of Action

The direction of actuator action can be changed by repositioning selector plug W3, which is factory set so that the actuator drives the valve stem down on increasing signal and draws it up on decreasing signal. When the valve stem is up, the output signal from the feedback (F) function is 0 or 2 Vdc. The output of the signal does not change when W3 is used to reverse the action of the actuator. See Fig. 15.

CHECKOUT

The actuator can be checked out either directly or by using a controller.

Direct Checkout

1. Mount the actuator for the required application; see Installation section.
2. Check the valve position and make sure that 24 Vac is correctly applied to the actuator.
3. Apply the power to the appropriate leadwires to move the valve.
4. If the actuator does not move, make sure the actuator is properly installed/wired.
5. If the actuator installation and wiring are both correct and the actuator does not run, replace the actuator.

Controller Checkout

1. Adjust the setpoint of the controller to call for opening the valve. Observe the actuator.
2. If the valve is closed, it should begin to open.
3. If the valve remains closed, move the setpoint further toward the open setting.
4. If the valve does not move, check for 24 Vac in the actuator power input.
5. If 24 Vac is present and the actuator does not operate, check the voltage across the controller leadwires to determine if the device is miswired.
6. If the wiring is correct, 24 Vac is present on the power input terminals, and the actuator does not run, replace the actuator.

Home and Building Control

Honeywell Inc.
Honeywell Plaza
P.O. Box 524
Minneapolis, MN 55408-0524

Honeywell Latin American Region

480 Sawgrass Corporate Parkway
Suite 200
Sunrise FL 33325

Home and Building Control

Honeywell Limited-Honeywell Limitée
155 Gordon Baker Road
North York, Ontario
M2H 3N7

Honeywell Europe S.A.

3 Avenue du Bourget
1140 Brussels
Belgium

Honeywell Asia Pacific Inc.

Room 3213-3225
Sun Hung Kai Centre
No. 30 Harbour Road
Wanchai
Hong Kong

Honeywell

