

# Conversion Wiring Diagrams for RM7890

The diagrams and instructions contained in this booklet are for converting the following models of primaries and programmers to RM7890 microprocessor based integrated burner control.

---

## TABLE OF CONTENTS

	Page
Product Selection Matrix .....	3
Honeywell R180B, R190B, R190C, RA190B, R890B,C, RA890B,C .....	5
Honeywell RA890E,G .....	6
Honeywell RA890F,H,J,K .....	7
Fireye TFM-1/UVM-1 .....	8
Protection Controls (Recycle Devices) 7256-B, -BE, -B5, -B5E, -BH, -BHE, -B5H, -B5HE .....	9
Protection Controls (Lockout Devices) 7256-BNR, -BNRE, BNRH, BNRHE, -B5NR, -B5NRE, -B5NRH, -B5NRHE .....	10



## **WARNING**

---

Improper configuration jumper selection could cause a fire or explosion hazard that could lead to property damage, severe injury or death.

---



## **CAUTION**

- 
1. Installer must be a trained, experienced, flame safeguard control service technician.
  2. Disconnect power supply before beginning installation to prevent electrical shock and equipment damage. More than one power supply disconnect may be involved.
  3. All wiring must comply with applicable local electrical codes, ordinances, and regulations.
  4. All line voltage terminal wiring shall be no. 14, 16 or 18 copper conductor TTW (60C) or THW (75C) or THHN (90C), 600 volt insulation wire. A maximum of two conductors can be wired to each Q7800 Subbase terminal.
  5. Voltage and frequency of the power supply and flame detector(s) connected to this control must agree with those marked on the device.
  6. Loads connected to the control terminals must not exceed ratings listed in Specification, form 65-0126, or on the RM7890 label.
  7. All external timers must be listed or component recognized by authorities having jurisdiction for the specific purpose for which they are used.
  8. Perform all required checkout tests after installation is complete.
-

**IMPORTANT:**

- 1. For on-off gas-fired systems, some authorities having jurisdiction prohibit the wiring of any limit or operating contacts in series between the flame safeguard control and the main fuel valve(s).
- 2. Do not connect more than two C7012E,F or C7076A,D Ultraviolet Flame Detectors (with self-checking shutter) in parallel to the same terminals.
- 3. This equipment generates, uses and can radiate radio frequency energy and if not installed and used in accordance with the instructions may cause interference to radio communications. It has been tested and found to comply with the limits for a

Class B computing device of Part 15 of FCC rules, which are designed to provide reasonable protection against such interference when operated in a commercial environment. Operation of this equipment in a residential area may cause interference, in which case, users at their own expense may be required to take whatever measures are required to correct this interference.

- 4. This digital apparatus does not exceed the Class B limits for radio noise for digital apparatus set out on the Radio Interference Regulations of the Canadian Department of Communications.

**SEQUENCE TIMING FOR NORMAL OPERATION:**

Device	Initiate	Standby	Main Flame Establishing Period	Run
RM7890A	10 sec.	*	4 or 10 sec	*
RM7890B	10 sec.	*	4 or 10 sec.	*

\*STANDBY and RUN can be an indefinite period of time.

**APPROVAL BODIES:**

Underwriters Laboratories Inc. listed: File No. MP268, Guide No. MCCZ.  
 Canadian Standards Association certified: LR9S329-3.  
 Factory Mutual approved: Report No. J11V9A0.AF.  
 Industrial Risk Insurers acceptable.  
 Federal Communications Commission, Part 15, Class B.  
 Canadian Department of Communications, CS-03, Certification No. 5733459A.

**MOUNTING:** Q7800A for panel mount or Q7800B for wall or burner mount.

**REQUIRED COMPONENTS:**

Q7800 Subbase  
 RM7847/48/49/86 Flame Amplifier

**ACCESSORIES:**

5-Wire Connector  
 —part no. 203541.  
 Combustion Service Manager  
 —part no. ZM7850A1001.  
 Communication Interface Base Unit  
 —part no. Q7700A1014.

**Communication Interface ControlBus Module**

—part no. QS7800A1001.  
**DATA CONTROLBUS MODULE™**  
 —part no. S7810A1009.  
 Dust Cover  
 —part no. 221729.  
 Electrical Access Slot Cover  
 —part no. 203765.  
 Expanded Annunciator  
 —part no. S7830A1005.  
 Flame Simulators  
 —part no. 203659 UV Flame Simulator.  
 —part no. 123514A Rectification Simulator.  
 Keyboard Display Module  
 —part no. S7800A1001.  
 Remote Display Mounting Bracket  
 —part no. 203765.  
 Remote Reset Module  
 —part no. S7820A1007.  
 Remote Display Power Supply  
 —part no. 203968 Plug-in.  
 Tester  
 —part no. A7800A1002.

# SELECTION MATRIX

## ON - OFF BURNER CONTROL

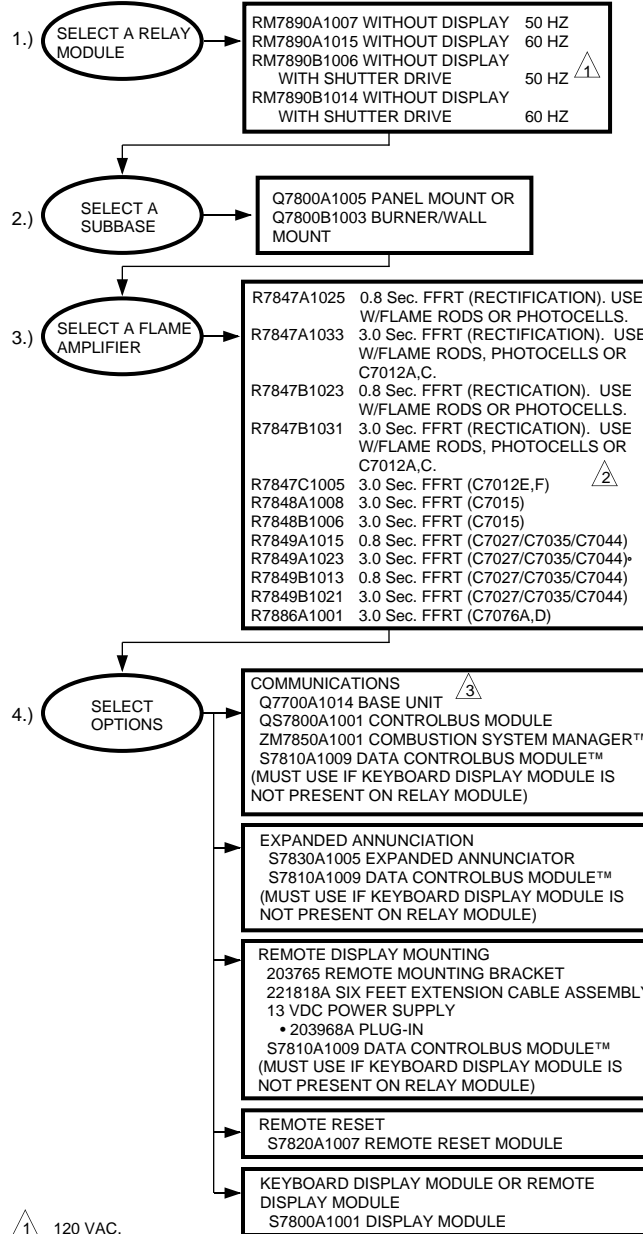



<sup>1</sup> 120 VAC.

<sup>2</sup> FFRT = FLAME FAILURE RESPONSE TIME.







<sup>3</sup> ONE Q7700 WILL SUPPORT ANY COMBINATION OF UP TO SIX (6) QS7700s/QS7800s.

M5156





### Directions:

1. Disconnect all power to primary or programmer.
2. Remove old primary or programmer from subbase.
3. Mark all wires on subbase; i.e., wires connected to terminal 1 should be marked "1".
4. Disconnect wires from subbase.
5. Remove old subbase.
6. Mount Q7800 Subbase.
7. Connect wires to subbase per wiring conversion for control being replaced. Pay close attention to footnotes. The symbol  designates a footnote.
8. Install the RM7890.
9. The RM7890 has two site configurable jumper options which are used to select Pilot Flame Establishing Period and Flame Failure Action. Refer to the RM7890 Instructions, form 60-0126, for assistance and proper selection.
10. If a low voltage controller is used on the RA890 or UVM-1, remove it and replace it with a line voltage controller. The line voltage controller should be connected in series with the limits. If it is desirable to retain the low voltage controller, then follow the procedure noted in Footnote .
11. Refer to the RM7890 Instructions, form 60-0126, for checkout and startup.

### General Footnotes:

-  Be sure system is modernized to 120 Vac. The replacement 7800 SERIES control is 120 Vac.
-  Select subbase.
-  Select proper flame amplifier according to the cross reference table. NOTE: The RM7890 control can be used with R7847/48/49/86 flame amplifiers.
-  Select proper flame detector if converting from a competitive control to Honeywell or if a different flame detection system is desired; i.e., old flame amplifier was flame rectification and new flame amplifier will be ultraviolet. Refer to the product selection matrix on page 3 for proper flame detector.
-  Proper grounding of the green subbase terminal screw to an electrical earth ground is a MUST for proper operation of the 7800 SERIES Control.
-  NOTE: UL allows only two electrical wires to each subbase terminal. Wiring information may show more than two wires to a particular terminal, which may require an external connection to accomplish the termination.
-  Select proper site configurable jumper configuration as required by the application. Refer to the cross reference table and to Specifications, form 65-0126.

NOTE: Jumper number 1 selects Pilot Flame Establishing Period and Jumper number 2 selects Flame Failure Action (Recycle or Lockout). Recycle option requires .8 second Flame Amplifier.

-  Do not use any unused subbase terminals as a wiring junction or termination point.
-  If a low voltage alarm has been used, remove it and replace with a line voltage alarm. Connect the alarm directly to the Q7800 Subbase terminal 4.
-  If Dynamic Self-Check has been selected for the flame amplifier (RM7890B only), then connect one of the shutter leads (white) of the C7012E/F or C7076A/D Flame Detector to the Q7800 Subbase terminal 22.
-  If a low voltage controller is being used, remove it and install a line voltage controller in series with the limits. If it is desirable to use a low voltage controller, then install an external relay with the N.O. contacts in series with the limits. The low voltage relay coil will be in the low voltage controller circuit. Note that it may be necessary to provide an external low voltage transformer.

# 7800 SERIES CONVERSION WIRING DIAGRAM

A B  
 FROM R180B, R190B, RA190B, R190C, 1 C TO RM7890  
 (DEVICE TO BE MODERNIZED) (O.S. NUMBER OF RELAY MODULE TO BE USED)

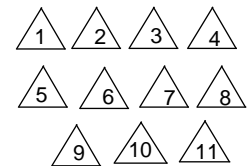
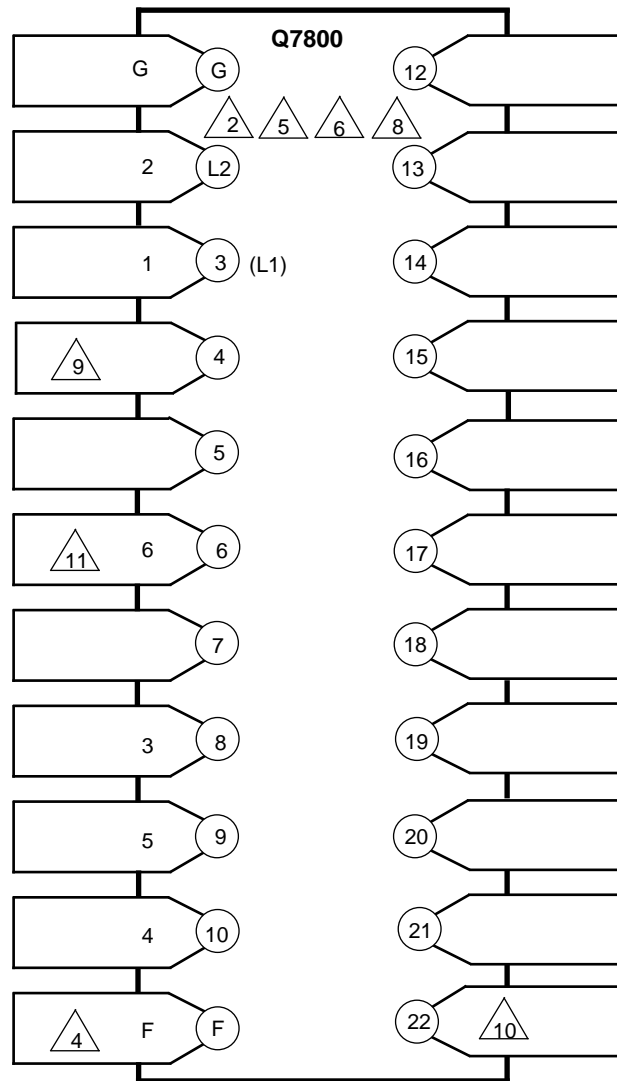

GENERAL FOOTNOTES,  
SEE PAGE 4.

A THE R190C IS USED ONLY IN THE W124 CONTROL PANEL. HONEYWELL RECOMMENDS MODERNIZING THE CONTROL PANEL TO RM7838A (REFER TO CONVERSION WIRING DIAGRAM FORM 65-0129 INSTEAD OF CONVERTING THE R190C TO RM7890).

B IF THE APPLICATION HAS EXTERNAL PURGE TIMING AND/OR AN EXTERNAL INTERRUPTED PILOT RELAY, THEN CONVERT TO RM7895. SEE CONVERSION WIRING DIAGRAM, FORM 65-0125.

C IF THE APPLICATION HAS A CONTINUOUS PILOT (STANDING PILOT), AN EXTERNAL RELAY WILL HAVE TO BE INSTALLED TO SWITCH THE F LEAD. THE RELAY MUST HAVE GOLD-CLAD OR GOLD-FLASH CONTACTS AND A 120 VAC COIL. POWER THE RELAY COIL FROM THE Q7800 SUBBASE TERMINAL 8. CONNECT THE RELAY CONTACTS BETWEEN THE F LEAD OF THE DETECTOR AND THE F TERMINAL OF THE Q7800 SUBBASE. THE R4222N1002 OR R4222V1002 RELAY IS ACCEPTABLE TO USE IN THIS TYPE OF APPLICATION. USE THE N.O. PILOT DUTY CONTACTS.

M5235

# 7800 SERIES CONVERSION WIRING DIAGRAM

FROM RA890E, G <sup>A</sup> <sup>B</sup> <sub>1 2 3</sub> TO RM7890  
 (DEVICE TO BE MODERNIZED) (O.S. NUMBER OF RELAY MODULE TO BE USED)

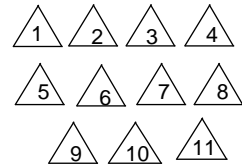
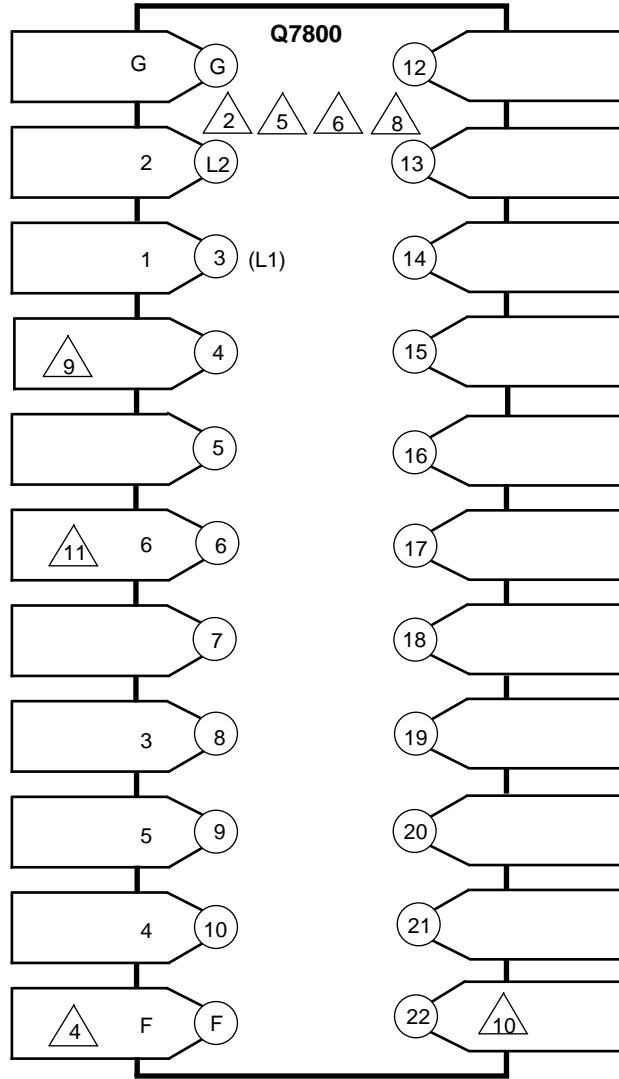

GENERAL FOOTNOTES,  
SEE PAGE 4.

<sup>A</sup> IF THE APPLICATION HAS EXTERNAL PURGE TIMING AND/OR AN EXTERNAL INTERRUPTED PILOT RELAY, THEN CONVERT TO RM7895. SEE CONVERSION WIRING DIAGRAM, FORM 65-0125.

<sup>B</sup> IF THE APPLICATION HAS A CONTINUOUS PILOT (STANDING PILOT), AN EXTERNAL RELAY WILL HAVE TO BE INSTALLED TO SWITCH THE F LEAD. THE RELAY MUST HAVE GOLD-CLAD OR GOLD-FLASH CONTACTS AND A 120 VAC COIL. POWER THE RELAY COIL FROM THE Q7800 SUBBASE TERMINAL 8. CONNECT THE RELAY CONTACTS BETWEEN THE F LEAD OF THE DETECTOR AND THE F TERMINAL OF THE Q7800 SUBBASE. THE R4222N1002 OR R4222V1002 RELAY IS ACCEPTABLE TO USE IN THIS TYPE OF APPLICATION. USE THE N.O. PILOT DUTY CONTACTS.

M5236

# 7800 SERIES CONVERSION WIRING DIAGRAM

FROM RA890 F, H, J, K <sup>A</sup> <sup>C</sup> <sup>E</sup> <sup>F</sup> <sub>1 2 3 4 5 6</sub> TO RM7890  
 (DEVICE TO BE MODERNIZED) (O.S. NUMBER OF RELAY MODULE TO BE USED)

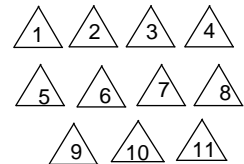
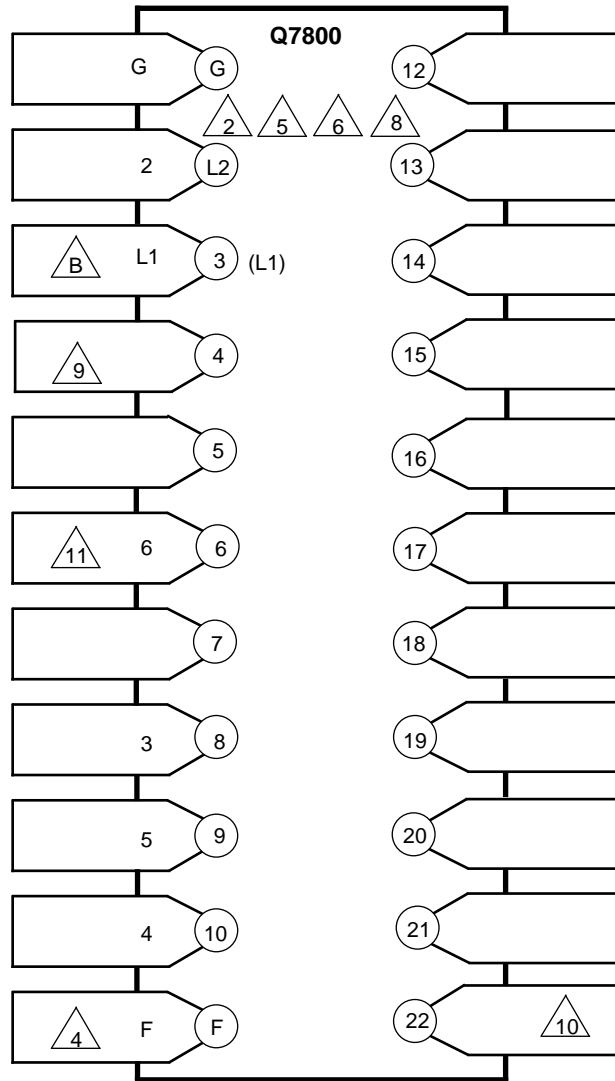

GENERAL FOOTNOTES,  
SEE PAGE 4.

<sup>A</sup> IF THE APPLICATION HAS EXTERNAL PURGE TIMING AND/OR AN EXTERNAL INTERRUPTED PILOT RELAY, THEN CONVERT TO RM7895. SEE CONVERSION WIRING DIAGRAM, FORM 65-0125.

<sup>B</sup> BRING L1 POWER FROM POWER SOURCE TO Q7800 SUBBASE TERMINAL 3.

<sup>C</sup> USE R7847B AMPLIFIER WITH RM7890 WHEN REPLACING RA890H.

<sup>D</sup> PUT 120 VAC RELAY COIL IN PARALLEL WITH THE PILOT VALVE (TERMINAL 8) WITH N.O. RELAY CONTACT IN SERIES WITH "F" LEAD. USE R784B AMPLIFIER WITH RM7890 TO REPLACE RA890J WITH STANDING PILOT. (SEE FOOTNOTE

<sup>F</sup> .)

<sup>E</sup> RA890K ENERGIZED LOAD RELAY IMMEDIATELY ON A CALL FOR HEAT. REPLACEMENT RM7890 DELAYS TO COMPLETE A SAFE-START CHECK.

<sup>F</sup> IF THE APPLICATION HAS A CONTINUOUS PILOT (STANDING PILOT), AN EXTERNAL RELAY WILL HAVE TO BE INSTALLED TO SWITCH THE F LEAD. THE RELAY MUST HAVE GOLD-CLAD OR GOLD-FLASH CONTACTS AND A 120 VAC COIL. POWER THE RELAY COIL FROM THE Q7800 SUBBASE TERMINAL 8. CONNECT THE RELAY CONTACTS BETWEEN THE F LEAD OF THE DETECTOR AND THE F TERMINAL OF THE Q7800 SUBBASE. THE R4222N1002 OR R4222V1002 RELAY IS ACCEPTABLE TO USE IN THIS TYPE OF APPLICATION. USE THE N.O. PILOT DUTY CONTACTS.

# 7800 SERIES CONVERSION WIRING DIAGRAM

FROM FIREYE TFM-1 / UVM-1  $\triangle$  A  $\triangle$  1 TO RM7890  
 (DEVICE TO BE MODERNIZED) (O.S. NUMBER OF RELAY MODULE TO BE USED)

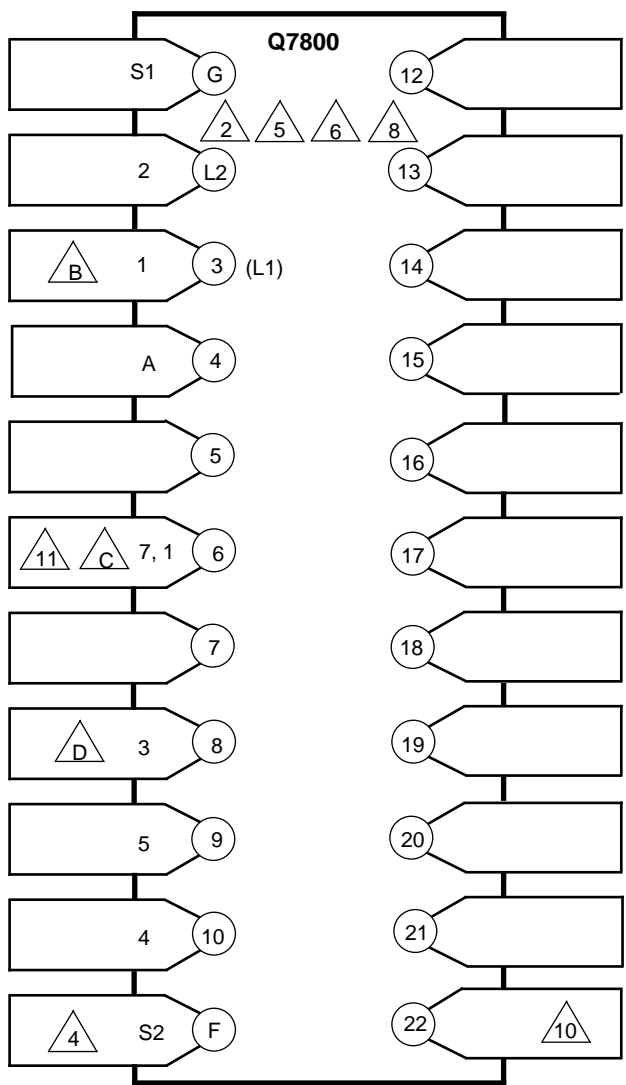

- $\triangle$  A IF THE DEVICE TO BE REPLACED HAS AN AIR FLOW SWITCH, THEN CONVERT TO RM7895. SEE CONVERSION WIRING DIAGRAM, FORM 65-0125.
- $\triangle$  B IN THE RM7890 DEVICE, THE Q7800 SUBBASE L1 TERMINAL (3) MUST BE POWERED DIRECTLY FROM THE HOT SUPPLY (L1). IN THE UVM-1 DEVICE, L1 WAS SUPPLIED TO THE DEVICE THROUGH THE LIMIT CONTROLS.
- $\triangle$  C IN THE UVM-1 DEVICE, THE LIMITS ARE CONNECTED TO TERMINAL 1 OF THE SUBBASE. IN THE UVM-1D, F, G AND TFM-1 D, F DEVICES, THE LIMITS ARE CONNECTED TO TERMINAL 7 OF THE SUBBASE.

- $\triangle$  D IF THERE IS A BLOWER MOTOR CONNECTED TO THE PILOT/IGNITION TERMINAL OF THE DEVICE BEING REPLACED, MAKE SURE THAT THE COMBINED CURRENT LOAD OF THE BLOWER MOTOR, PILOT AND IGNITION DOES NOT EXCEED THE MAXIMUM RATING OF RM7890 TERMINAL 8. REFER TO SPECIFICATION, FORM 65-0126, OR DEVICE LABEL. IF THE COMBINED LOAD EXCEEDS THE MAXIMUM TERMINAL RATING, THEN A BLOWER CONTACTOR WILL HAVE TO BE USED.



# 7800 SERIES CONVERSION WIRING DIAGRAM

A PROTECTION CONTROLS (RECYCLE) B  
 FROM 7256-B, -BE, -B5, -B5E, -BH, -BHE, -B5H, -B5HE TO RM7890  
 (DEVICE TO BE MODERNIZED) (O.S. NUMBER OF RELAY MODULE TO BE USED)

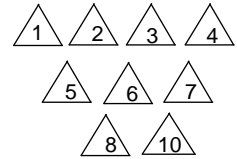
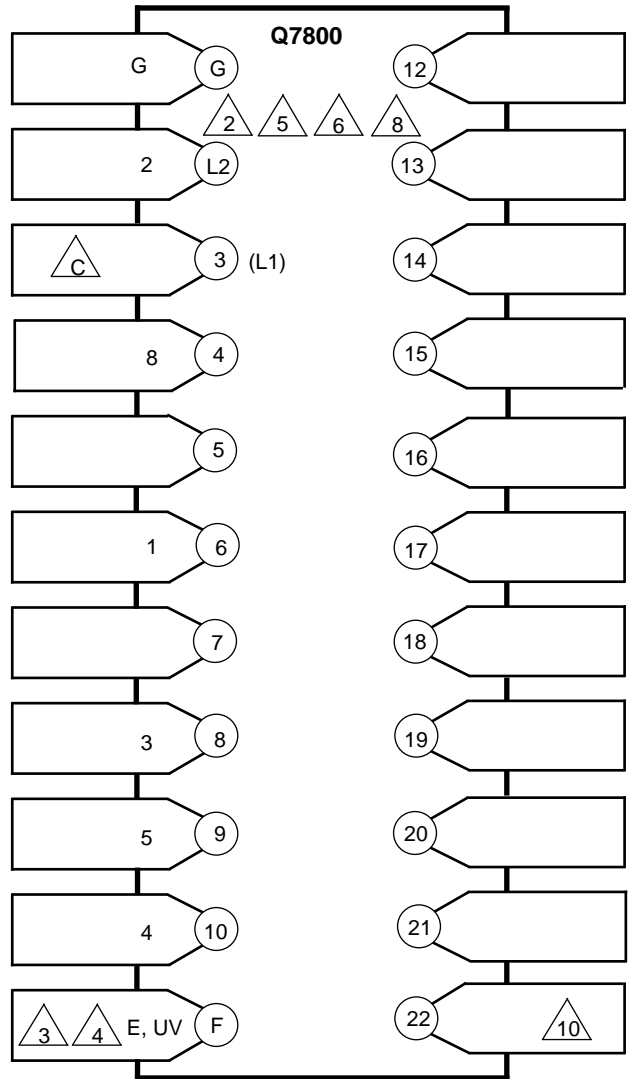

GENERAL FOOTNOTES,  
SEE PAGE 4.

A THESE DEVICE TYPES WOULD RECYCLE ON A FLAME FAILURE. TO MAINTAIN THIS FUNCTION, KEEP JUMPER 2 OF THE RM7890 DEVICE INTACT. REFER TO SPECIFICATION, FORM 65-0126.

C THE RM7890 DEVICE REQUIRES ITS L1 TERMINAL (3) TO BE POWERED DIRECTLY FROM THE MASTER DISCONNECT SWITCH.

B DEVICE TYPES 7256-BE, -B5E, -B5H, B5HE HAVE A FIVE SECOND PILOT FLAME ESTABLISHING PERIOD. TO MAINTAIN THIS FUNCTION, JUMPER 1 OF THE RM7890 DEVICE WILL HAVE TO BE CLIPPED. REFER TO SPECIFICATION, FORM 65-0126. NOTE THAT CLIPPING JUMPER 1 WILL RESULT IN A FOUR SECOND PILOT FLAME ESTABLISHING PERIOD.

M5239

# 7800 SERIES CONVERSION WIRING DIAGRAM

PROTECTION CONTROLS (LOCKOUT) △ A  
 7256-BNR, -BNRE, -BNRH, -BNRHE, △ B  
 FROM -B5NR, -B5NRE, -B5NRH, -B5NRHE TO RM7890  
 (DEVICE TO BE MODERNIZED) (O.S. NUMBER OF RELAY MODULE TO BE USED)

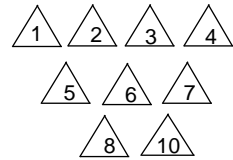
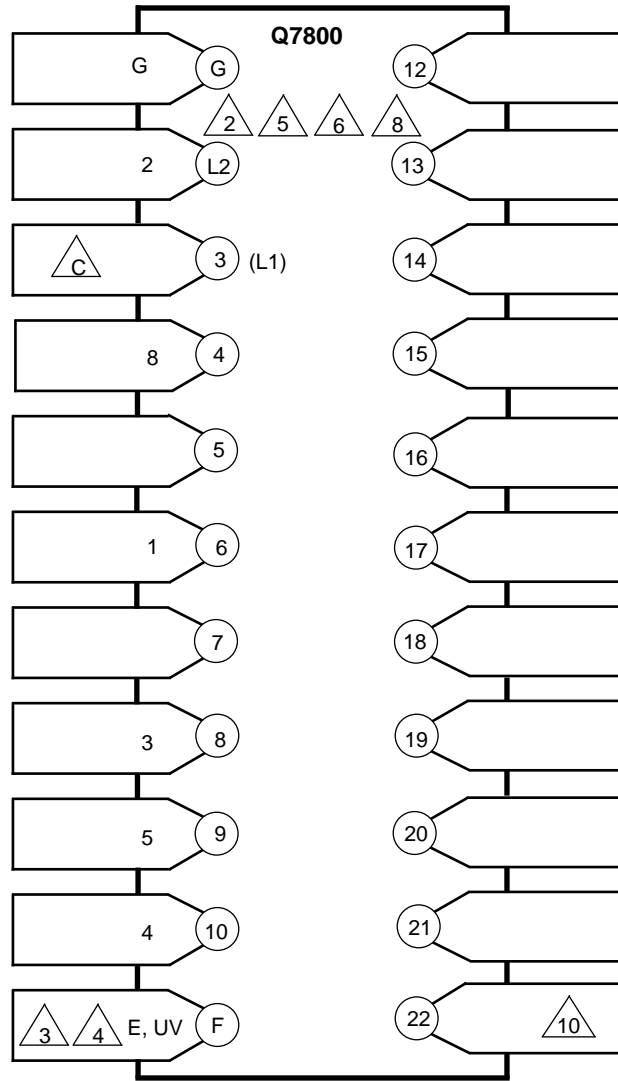

GENERAL FOOTNOTES,  
SEE PAGE 4.

△ THESE DEVICES TYPES WOULD LOCKOUT ON A FLAME FAILURE. TO MAINTAIN THIS FUNCTION, JUMPER 2 OF THE RM7890 DEVICE MUST BE CLIPPED. REFER TO SPECIFICATION, FORM 65-0126.

△ THE RM7890 DEVICE REQUIRES ITS L1 TERMINAL (3) TO BE POWERED DIRECTLY FROM THE MASTER DISCONNECT SWITCH.

△ DEVICE TYPES 7256-B5NR, -B5NRE, -B5NRH, B5NRHE HAVE A FIVE SECOND PILOT FLAME ESTABLISHING PERIOD. TO MAINTAIN THIS FUNCTION, JUMPER 1 OF THE RM7890 DEVICE WILL HAVE TO BE CLIPPED. REFER TO SPECIFICATION, FORM 65-0126. NOTE THAT CLIPPING JUMPER 1 WILL RESULT IN A FOUR SECOND PILOT FLAME ESTABLISHING PERIOD.



**Honeywell**

*Helping You Control Your World*

---

**Home and Building Control**

Honeywell Inc.  
1985 Douglas Drive North  
Golden Valley, Minnesota 55422

**Home and Building Control**

Honeywell Limited—Honeywell Limitée  
740 Ellesmere Road  
Scarborough, Ontario  
M1P 2V9

Printed in U.S.A.



**QUALITY IS KEY**