

V4943/V8943B,C,N; V4944/V8944B,C,L,N Regulating Diaphragm Gas Valves

PRODUCT DATA

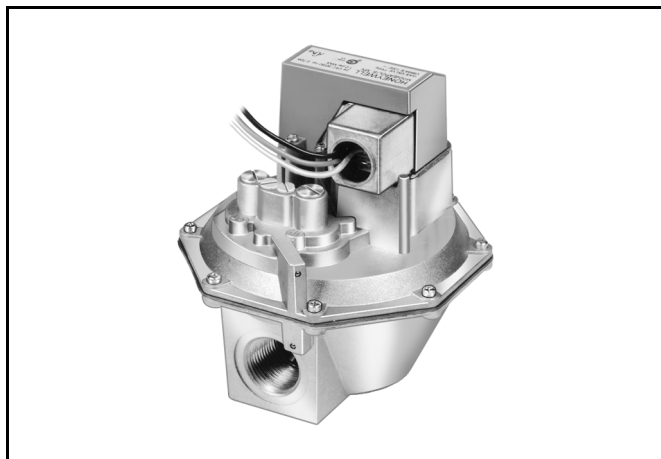

APPLICATION

The V4943/V8943B and N (single stage) and V4944/V8944B and N (two stage) are solenoid-operated diaphragm valves suitable for natural gas only. The V4943/V8943C and V4944/V8944C and L are solenoid-operated diaphragm valves suitable for Liquefied Petroleum (LP) gas only. These valves are used on boilers, unit heaters, duct furnaces, makeup air and rooftop heaters.

FEATURES

- Models are available for natural or liquid petroleum (LP) gases.
- Valve models L, N are rapid opening (less than six seconds) and fast closing, and are available for LP and natural gases, respectively.
- Line voltage with two-wire thermostat or controller is used with V4943; V8943 is used with 24V thermostat or controller.
- V4944 is used with line voltage dual-stage thermostat or controller; V8944 is used with 24V dual-stage thermostat or controller.
- Slow opening B,C valve models are available for natural and LP gases respectively.
- Valve closes on power failure; recommended for final shutoff service.
- Valve closing time: 2 seconds maximum at 7 inches wc inlet pressure.
- Valves rated for 0.5 pound per square inch (psi) (3.4 kPa).
- Leadwires and cover for electrical conduit connections are provided.

Contents

Application.....	1
Features	1
Specifications	2
Ordering Information	2
Installation	6
Operation	9
Checkout and Troubleshooting	10
Service Information	11



SPECIFICATIONS

Models:

All models are solenoid-operated regulating diaphragm gas valves. Details are shown in Table 1.

Table 1. Model Availability.

Model	Voltage and Frequency	Maximum Current	Power Consumption (VA Maximum)	Pipe Size (in.)	Thread Type	Maximum Operating Pressure		Opening Time (sec.)	Pressure Regulation	Type of Gas	Number of Lead-wires
						psi	kPa				
V4943B	120V (+10%, -15%), 60 Hz	0.055A	6.6	1, 1-1/4, 1-1/2, 2	NPT	0.5	3.4	3 to 25	Single stage	Natural ^a	2
V4943N				1, 1-1/4, 1-1/2				<6			
V8943B	24V, (+10%, -15%) 50/60 Hz	0.363A	9.0	1, 1-1/4, 1-1/2, 2				3 to 25		LP	
V8943C				1, 1-1/4							
V8943N				1, 1-1/4, 1-1/2				<6			
V4944B	120V (+10%, -15%) 60 Hz	0.077A	9.0	1, 1-1/4, 1-1/2				3 to 25	Two stage	LP	3
V4944C											
V4944L				1-1/4				<6			
V4944N				1, 1-1/4, 1-1/2, 2							
V8944B	24V (+10%, -15%) 50/60 hz	0.516A	12.4	1, 1-1/4, 1-1/2, 2				3 to 25		LP	
V8944C				1, 1-1/4, 1-1/2							
V8944L				1, 1-1/4				<6			
V8944N				1, 1-1/4, 1-1/2, 2							

^a Includes natural gas, mixed air-natural gas, LP gas-air.

Flow Capacity: See Table 2.

ORDERING INFORMATION

When purchasing replacement and modernization products from your TRADELINE® wholesaler or distributor, refer to the TRADELINE® Catalog or price sheets for complete ordering number.

If you have additional questions, need further information, or would like to comment on our products or services, please write or phone:

1. Your local Honeywell Automation and Control Products Sales Office (check white pages of your phone directory).
2. Honeywell Customer Care
1885 Douglas Drive North
Minneapolis, Minnesota 55422-4386

In Canada—Honeywell Limited/Honeywell Limitée, 35 Dynamic Drive, Scarborough, Ontario M1V 4Z9.

International Sales and Service Offices in all principal cities of the world. Manufacturing in Australia, Canada, Finland, France, Germany, Japan, Mexico, Netherlands, Spain, Taiwan, United Kingdom, U.S.A.

Table 2. V4/8943 and V4/8944 Flow Capacity.

Pipe Size (in.)	CSA Certified 1.0 in. pd Natural Gas cfh	Btuh per 1000 cfh Natural gas	Regulation Capacities 0.64 sp gr Natural Gas	
			Maximum cfh	Minimum cfh
1	1,000	1,000,000	1,000	300
1-1/4	1,600	1,600,000	1,600	480
1-1/2	2,300	2,300,000	2,300	780
2	3,000	3,000,000	3,000	870

Valve Pattern: Straight-through, non offset.

Valve Body Material: Die-cast aluminum.

Electrical Terminations: 1/4 in. (6 mm) spade terminals (quick connects). Leadwires and cover for electrical conduit connections are provided.

Valve Closing Time: On power failure, a maximum of 2 seconds at 7 in. wc inlet pressure.

Ambient Temperature Ratings: -40°F to +150°F (-40°C to +66°C).

Maximum Fluid Temperatures: 150°F (66°C).

Standard Factory Settings: See Table 3.

Dimensions: See Fig. 1.

Weight:

1 in., 1-1/4 in. valves: 4 lb (1.8 kg).

1-1/2 in., 2 in. valves: 5 lb (2.3 kg).

Table 3. Factory Settings and Regulation Ranges.

Firing stages ^a	Natural Gas (i.e. B, N models)		LP Gas (i.e. C, L models)	
	Factory Setting	Adj. Range	Factory Setting	Adj. Range
Low Fire:				
Standard Models	0.8" wc	0.8" to 2" wc	1.4" wc	1.4" to 4.2" wc
Special Models (Group 1)	1.6" wc	1.6" to 4.2" wc		
Special Models (Group 2)	0.8" wc	0.8" to 2" wc		
Special Models (Group 3)	0.8" wc	0.8" to 2" wc		
High Fire:				
Standard Models	3.5" wc	3" to 4.5" wc	10" wc	8.8" to 11.5" wc
Special Models (Group 1)	3.5" wc	3" to 4.5" wc		
Special Models (Group 2)	3.5" wc	1.4" to 4.2" wc		
Special Models (Group 3)	5" wc	4.0" to 7" wc		

^a V4943 is a single-stage valve, please refer to "High Fire" for spring specifications.

Special Models (Group 1): V4944B1075, V4944B1083, V4944B1091, V8944B1092, V8944B1100, V8944B1118

Special Models (Group 2): V4944B1109, V4944B1125, V4944B1141, V4944B1166; V4943B1050, V4943B1068, V4943B1076, V4943B1084

Special Models (Group 3): V4944B1117, V4944B1133, V4944B1158; V4943B1092, V4943B1100, V4943B1118

Approvals:

Underwriters Laboratories Listed: File Number MH1639

CSA Certified: Report Number C2030020 (except those listed as Special Models Group 2 and Special Models Group 3)

Commonwealth of Massachusetts Product Certification Number: G1-12-05-22

Mounting Position:

Standard Position: Upright (horizontal).

Accessories:

AT72D Transformer (40 VA) for all 24 Vac models.

NOTE: V4944B1059, V4944N1052 and V4944N1060 can be mounted upright to 90 degrees from the upright on the horizontal axis with respect to the inlet connection.

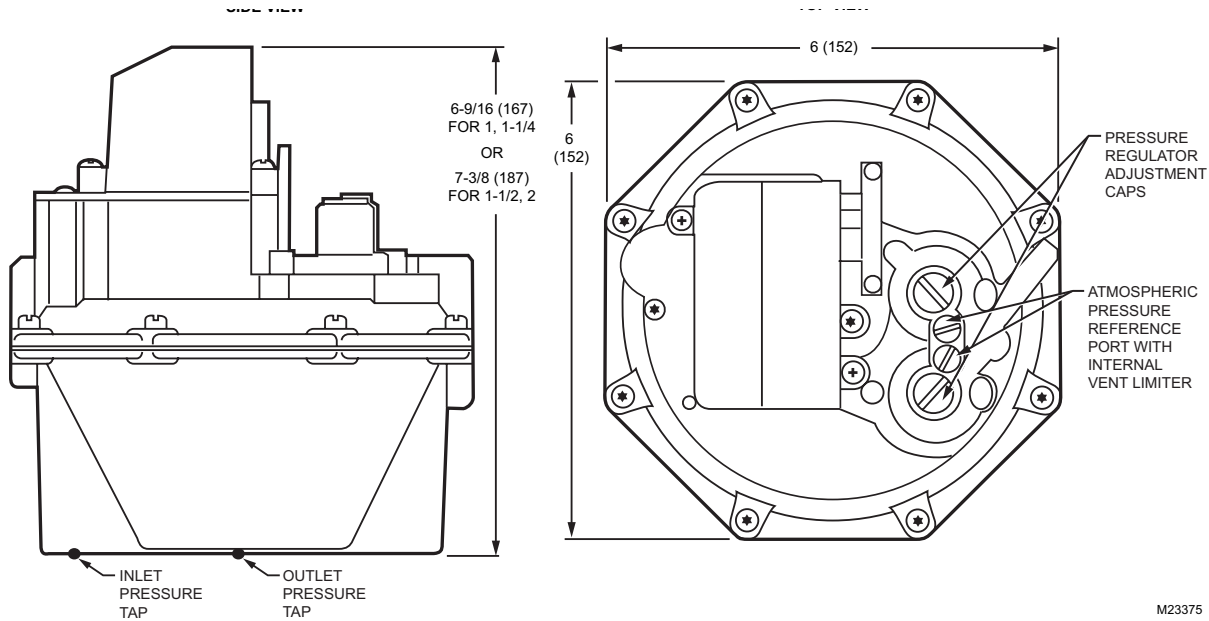

Fig. 1. V4943/44 and V8943/44 dimensions in in. (mm).

Gas Valve Sizing

1. Check the burner nameplate for:
 - a. the type of gas used, and
 - b. the gas flow capacity. The capacity will be listed in British thermal units per hour (Btuh) or in cubic feet per hour (cfh).
2. Contact the local gas utility for information regarding:
 - a. the specific gravity (sp gr) and
 - b. the Btu per cubic foot (Btucf) for the type of gas used.

3. Find the capacity in cf/h. If the capacity is listed in Btu, convert to cf/h using the following formula:

$$\text{Capacity in cfh} = \frac{\text{Btuh (burner nameplate)}}{\text{Btu/cf (gas utility)}}$$

4. For gases with specific gravities other than 0.64, multiply the burner cf/h using the proper conversion factor in Table 4.

Table 4. Gas Conversion Factors.

Type of Gas	sp gr (average)	Multiply cfh by
Manufactured	0.60	0.968
Mixed	0.70	1.046
LP-Propane	1.53	1.546
LP-Butane	1.98	1.759

5. Use the corrected burner capacity in cfh when determining the gas valve size in Fig. 2-10.
6. Determine the maximum pressure drop across the valve and draw a vertical line at this pressure in Fig. 2-10.

7. At the point of intersection of the vertical line and the curve, draw a horizontal line to intersect the flow (capacity) scale. The point of intersection indicates the capacity that can be obtained with the maximum pressure drop.
8. If the capacity at the maximum pressure drop is insufficient, use the capacity vs. pressure drop curve for the next larger valve size and repeat steps 6 and 7.

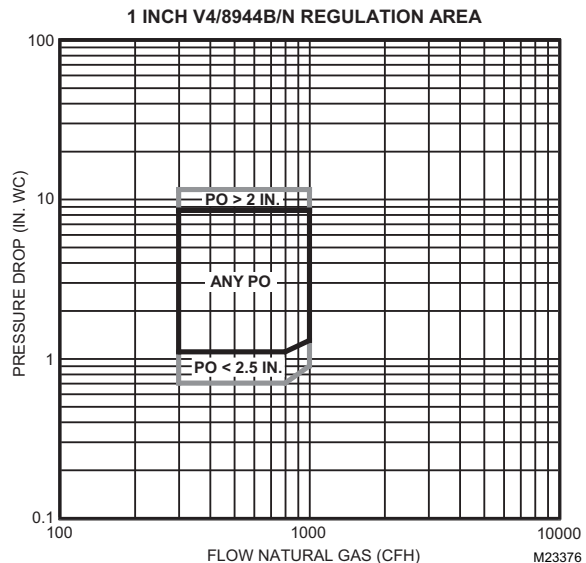

Fig. 2. Capacity vs. pressure drop of Natural Gas curves for 1 in. valve.

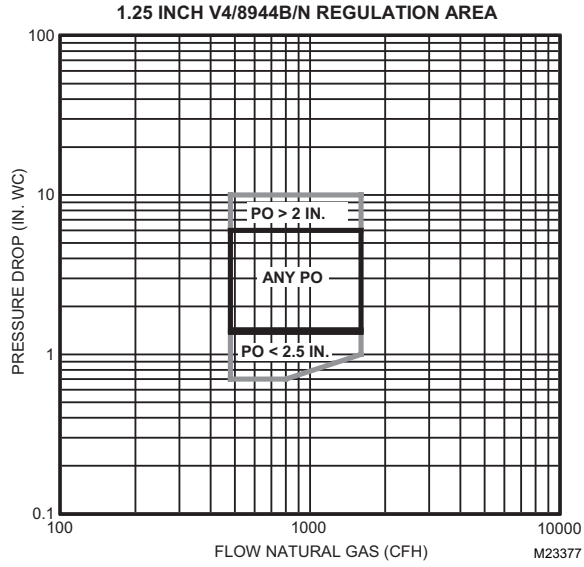

Fig. 3. Capacity vs. pressure drop of Natural Gas curves for 1-1/4 in. valve.

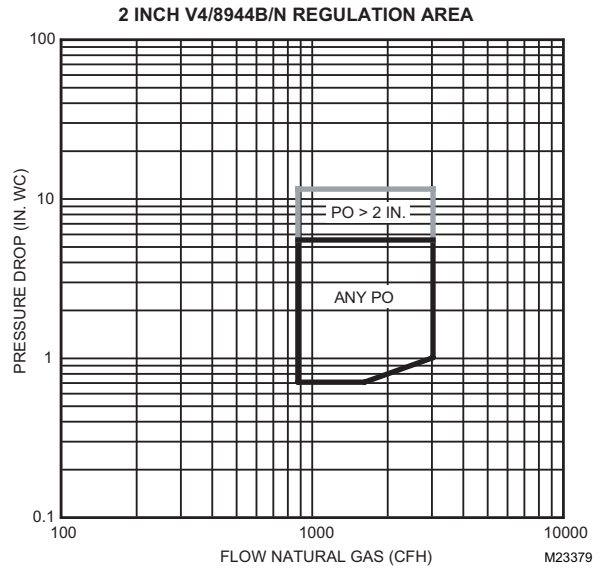

Fig. 5. Capacity vs. pressure drop of Natural Gas curves for 2 in. valve.

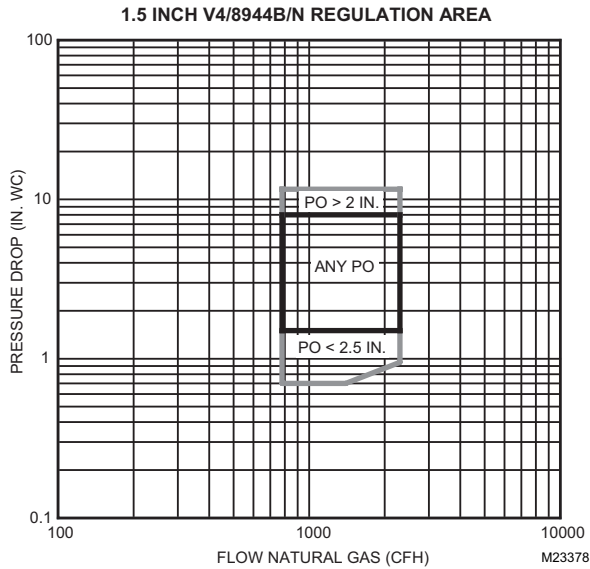

Fig. 4. Capacity vs. pressure drop of Natural Gas curves for 1-1/2 in. valve.

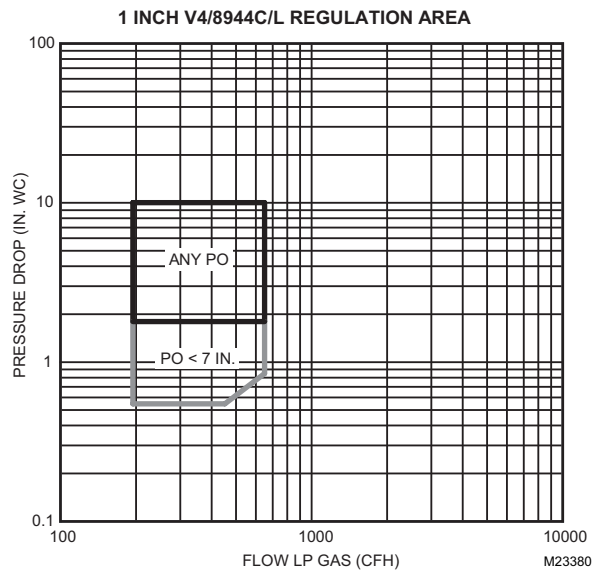

Fig. 6. Capacity vs. pressure drop of LP Gas curves for 1 in. valve.

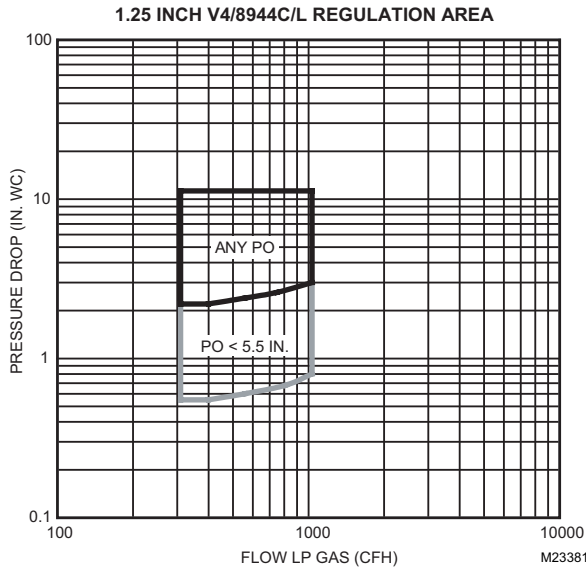

Fig. 7. Capacity vs. pressure drop of LP Gas curves for 1-1/4 in. valve.

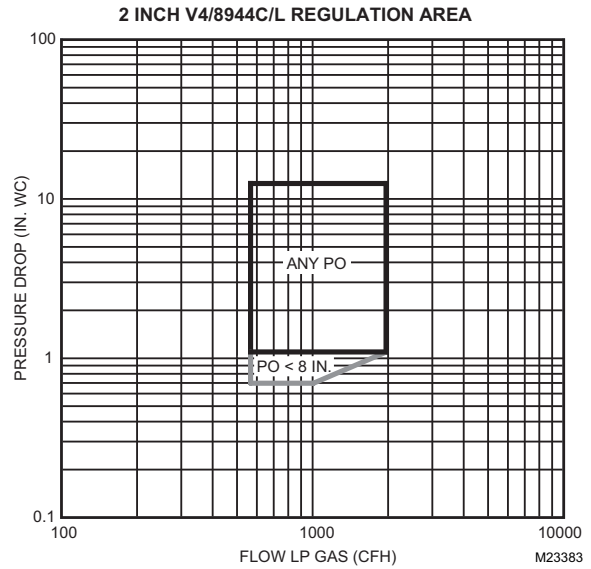

Fig. 9. Capacity vs. pressure drop of LP Gas curves for 2 in. valve.

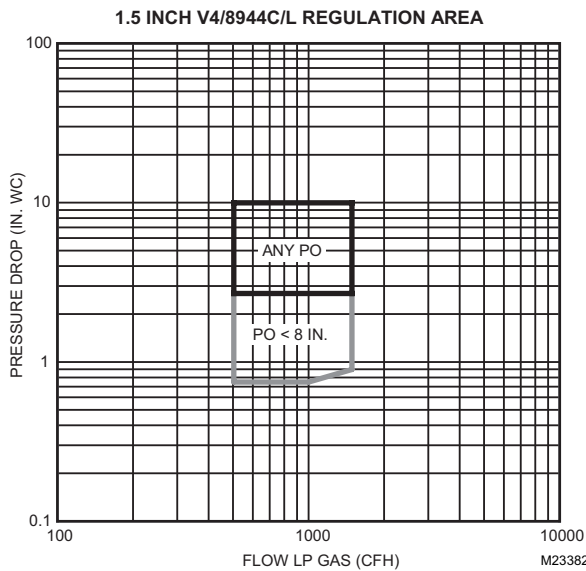

Fig. 8. Capacity vs. pressure drop of LP Gas curves for 1-1/2 in. valve.

To size two identical valves piped in series:

1. Find the cf/h for the type of gas used.
2. Consider both valves as one unit. Determine the maximum pressure drop across the one unit.
3. Find the pressure drop across the first valve by assuming it to be 45 percent of the total pressure drop.
4. Find the valve size from Fig. 2–9.
5. The second valve will be the same size as the first valve.

INSTALLATION

⚠ WARNING

Explosion hazard.
Can cause serious injury, death or equipment damage.
 Installation and service by trained professionals only. Exceeding the pressure rating or use of unspecified fuel can lead to improper operation of the valve and can create an explosion hazard. Property damage, severe bodily injury or death can result.

When installed in the Commonwealth of Massachusetts, the installation and servicing of this product must be done by a licensed gas fitter or plumber.

Consult specifications before installing valve.

When Installing this Product...

1. Read these instructions carefully. Failure to follow them could damage the product or cause a hazardous condition.
2. Check the ratings given in the instructions and on the product to make sure the product is suitable for your application.

3. Installer must be a trained experienced flame safeguard control technician.
4. After installation is completed, check out product operation as provided in these instructions.

⚠ WARNING

Explosion hazard and electrical shock hazard. Can cause serious injury or death.

1. Turn off gas supply before starting installation.
2. Disconnect power supply before beginning installation to prevent electrical shock and equipment damage.
3. Do not remove seal over valve inlet or outlet until ready to connect piping.

Prepare Piping and Install Valve (Fig. 10).

1. Use new, properly reamed pipe free from chips.
2. Do not thread pipe too far. Valve distortion or malfunction can result from excess pipe in valve.
3. Apply good quality pipe dope resistant to the action of LP gas; put a moderate amount only on the pipe threads. If pipe dope lodges on the valve seat, it will prevent proper closure.
4. Install the valve in a horizontal pipe line in an upright position with the gas flow in the direction indicated by the arrow on the casing. The valve must be upright

(electrical connection tower in the up position) on a horizontal axis with respect to the inlet connection (see Fig. 10). Certain models may be mounted in the limited horizontal position (any position from upright to 90 degrees to upright on an horizontal axis with respect to the inlet connection. See Specifications section.)

5. Apply a parallel jaw wrench only to the flat next to the pipe being inserted. A wrench applied to the valve body itself or to the end farthest from the pipe being inserted can distort the casting and cause a malfunction.
6. The gas flow must be in the same direction as the arrow on the bottom of the valve body.

⚠ WARNING

Explosion and Fire Hazard. Can cause serious injury or death.

If flow is not in direction of arrow, valve may not shut off; which can cause excess gas and harm to equipment or personnel.

7. Make electrical connections as illustrated in the wiring diagrams (see Fig. 11–14).
8. Turn on the main gas and, with a soap solution, check the valve installation for leaks.
9. The V4943/V8943, V4944/V8944 combination valve pressure regulating sections are provided with integral vent limiters.

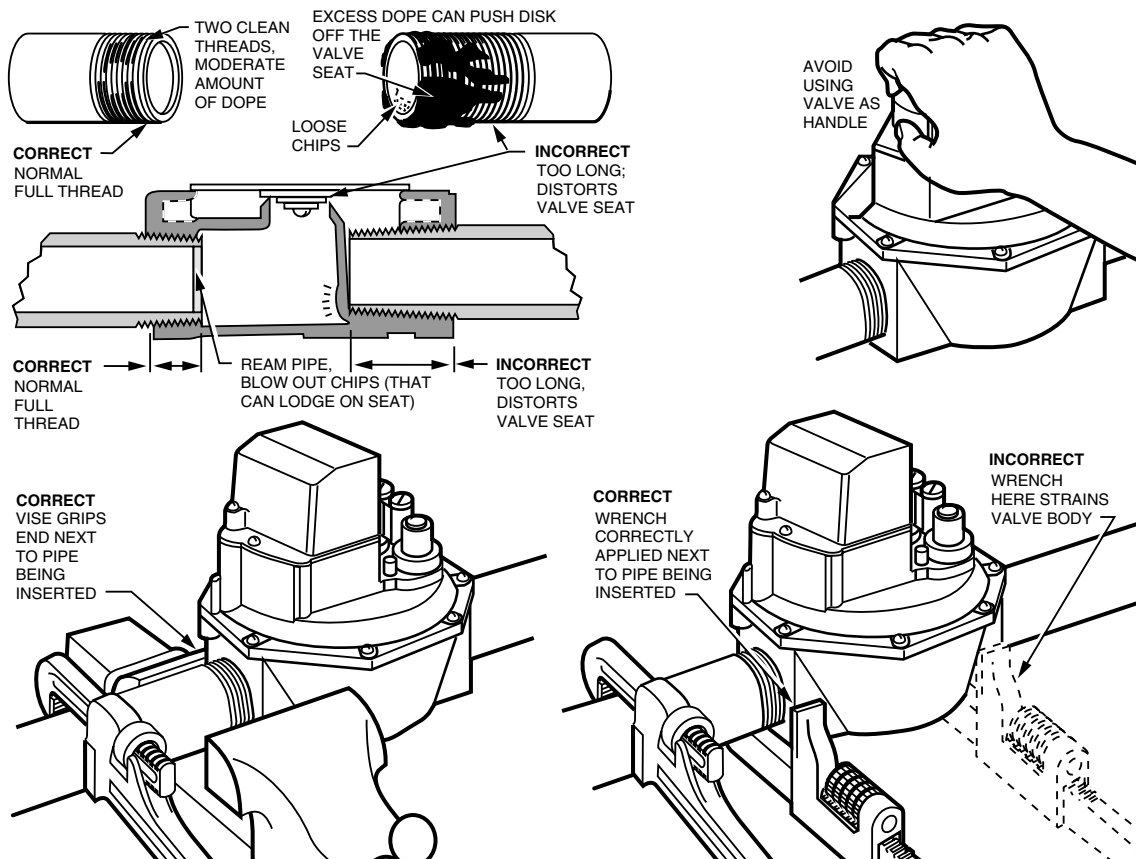

Fig. 10. Preparing the piping and installing the valve.

Wiring

WARNING

Electrical Shock Hazard.
Can cause serious injury, death or equipment damage.
 Disconnect the power supply before making connections to prevent electrical shock and equipment damage.

1. All wiring must comply with applicable electrical codes, ordinances and regulations. Use NEC Class 1 (line voltage) wiring.
2. For normal installations, use moisture-resistant No. 14 wire suitable for at least 167°F (75°C) when using a flame safeguard primary control, or for at least 194°F (90°C) when using a flame safeguard programming control.
3. For high temperature installations, use moisture-resistant No. 14 wire selected for a temperature rating above the maximum operating temperature.
4. Check the power supply circuit. The voltage and frequency must match those of the valve.
5. See Fig. 11 through 14 for typical field wiring connections. Follow the burner manufacturer wiring diagram, if provided.
6. Make wiring connections at the electrical wires provided at the top of the valve.

CAUTION

Equipment Damage Hazard.
Miswiring can cause equipment damage.

1. Label all wires prior to disconnection when servicing valves. Wiring errors can cause damage to the equipment through improper and dangerous operation.
2. Verify proper operation after servicing.
3. After the installation is complete, cycle the valve several times with the manual fuel shutoff cock closed. Make sure the valve and actuator function properly.
4. If the installation is gas tight and functioning properly, proceed to the Checkout section.

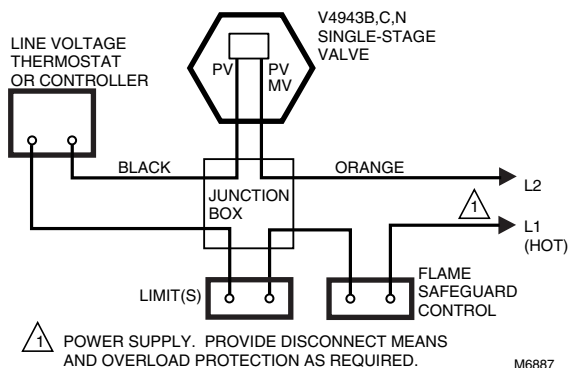

Fig. 11. Typical wiring diagram for V4943B,N.

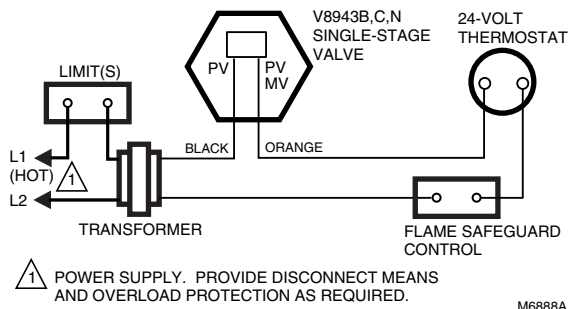

Fig. 12. Typical wiring diagram for V8943B,C,N.

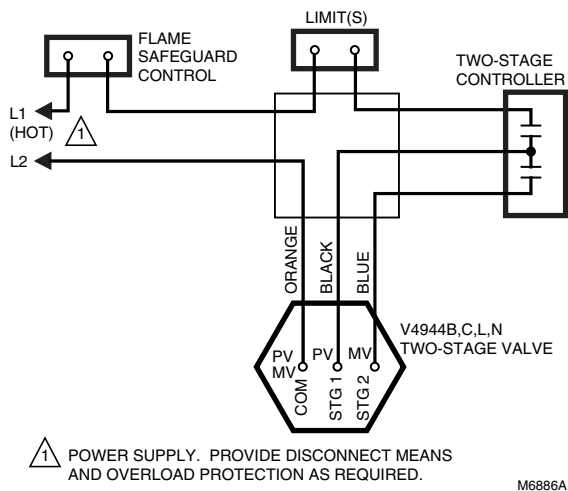

Fig. 13. Typical wiring diagram for V4944B,C,L,N with three leadwire electrical termination.

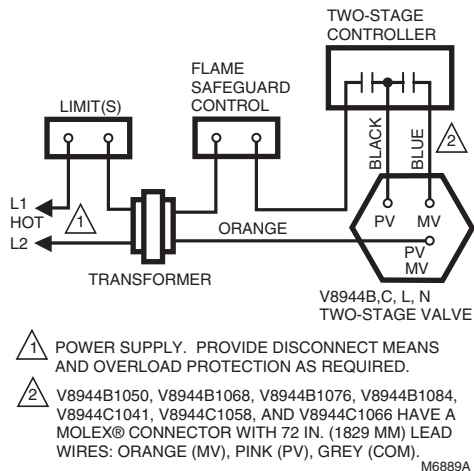

Fig. 14. Typical wiring diagram for V8944B,C,L,N with three leadwire electrical termination.

OPERATION

General

The V4943/V8943B,C, N and V4944/V8944B,C,L, N Valves are solenoid-operated diaphragm gas valves with one or two stages of regulation. They can operate as a shut-off valve and a pressure regulating valve. The V4943/V8943B,C,N have a single stage of regulation (high fire) and the V4944/V8944B,C,L,N have two stages of regulation (high fire and low fire). The models with L and N suffixes are rapid opening devices while the B- and C-suffixed models are slow opening devices.

In a redundant valve (two valves in series) system, it is recommended that the V4943/V8943B,C, N and V4944/V8944B,C,L, N Valves be positioned downstream from the redundant valve for proper operation of the pressure regulator(s). The V4943/V8943N and V4944/V8944L,N models have a 0.022 in. bleed orifice in the bleed line (the valves bleed internally to the outlet side) and are rapid opening valves (maximum opening time is six seconds). The V4943/V8943B,C and V4944/V8944B,C models have bleed orifices varying in diameter from 0.014 in. to 0.018 in. to control the opening time.

The range of outlet pressure is adjusted by turning a screw which changes the compression in the regulator spring. The valves are suitable for natural gas (B and N models) or LP (C and L models) applications.

Leadwires and a cover for electrical conduit connections are provided with each valve.

The valves are available in 1 in., 1-1/4 in., 1-1/2 in. and 2 in. sizes. The 1 in. and 1-1/4 in. valves share a common body casting and the 1-1/2 in. and 2 in. valves share a larger body casting. The valves are intended to replace the V4843/V8843B,C,N and V4844/V8844B,C,N lines of valves.

The valves are used as combination controls, providing both pressure regulation and shutoff functions for burners. Typical burner applications include boilers, process equipment, ovens, incinerators, water heaters, rooftop units, and commercial/ industrial atmospheric/power burners. The burner firing rates range from 400 kbtu/hour to 5,000 kbtu/hour.

Operation of the V4943B,C,N/V8943B,N

The V4943/V8943B,C,N Valves are combination gas controls that include a single stage of pressure regulation in addition to the shut-off function. They have a single solenoid and a single regulating diaphragm.

When the controller is not calling for heat, the valve solenoid coil is not energized. Static gas inlet pressure and a spring act together to close the valve. In this condition, a three-way servo valve directs inlet pressure directly above the main diaphragm, creating static pressure on both sides of the main diaphragm.

On a call for heat, the controller contacts close and the valve solenoid coil is energized, opening the servo valve and allowing the gas that is above the main diaphragm to bleed downstream, and diverting inlet (supply) gas through a supply orifice. This reduces the pressure above the diaphragm, and the gas that is bled off flows through a regulating valve to the outlet of the gas valve. The pressure differential across the

main diaphragm is greater than the spring force, so the valve opens. The valve opening rate is controlled by a timing orifice through which the bleed gas passes.

Once the valve is open, outlet pressure is sensed through the bleed passage. The outlet pressure acts on the regulating (servo) diaphragm and tends to open or close the integral regulating valve until a force balance is established between the outlet pressure acting on the servo diaphragm and the regulator spring that acts on the atmospheric side of the servo diaphragm.

The system is balanced when the flow of supply gas through the supply orifice is equal to the outflow of gas through the regulating valve. The regulated output pressure required to achieve equilibrium is varied by increasing or decreasing the spring force acting on the atmospheric side of the regulating diaphragm. Pressure adjustment is done through the use of a threaded nylon screw acting on the regulating spring. Regulator springs with different spring rates provide the various ranges of pressure regulation needed for natural and LP gases.

After the controller is satisfied, the procedure is reversed. The controller contacts open and the solenoid coil is de-energized. The plunger is released, moving to the down position. The servo valve closes, diverting supply gas away from the orifice and allowing the gas inlet pressure to act directly above the main diaphragm. The resulting increase in upper chamber pressure, along with the main spring, forces the main diaphragm against the valve seat, stopping the gas flow.

In the event of a power failure during automatic operation of the valve, the V4943/V8943B,C,L,N Valve servo valve closes, diverting supply gas away from the orifice and allowing the gas inlet pressure to act directly on the main diaphragm. The change in upper chamber pressure, along with the main spring, forces the main diaphragm against the valve seat, stopping the gas flow. Normal operation will resume upon the restoration of power.

Operation of the V4944/V8944B,C,L,N Valves

These models use two pressure regulators (low fire and high fire) and two solenoids to provide two distinct stages of pressure regulation. The first stage pressure regulator solenoid activates the same quick-close orifice valve and servo valve as in the V4943/V8943 models, but the bleed gas now flows through a first stage (low fire) regulator valve to the outlet. This maintains the outlet at a pressure controlled by the low fire regulator. The second stage regulator (high fire) is set to a higher outlet pressure. When the second stage solenoid is energized, gas is shunted past the low fire regulator through a timing orifice. The increased flow of supply gas (due to the second servo valve opening) further reduces the pressure above the main diaphragm, causing it to open more. The corresponding increase in outlet pressure forces the low fire regulator closed, and the valve regulates off the high fire regulator.

The V4944/V8944L and N models use a timing orifice that gives an opening time to low fire of less than six seconds. The slower opening V4944/V8944B and C use timing orifices that give an opening time of three to 25 seconds.

Both regulators can be adjusted separately and the springs are sized so that the highest achievable pressure of the low pressure regulator range is less than the lowest achievable

pressure of the high fire pressure regulator. The high fire setpoint cannot be achieved without the first stage solenoid being energized.

Valve closing operation is identical to that described for V4943/V8943B,C,N valves.

CHECKOUT AND TROUBLESHOOTING

WARNING

Explosion or Fire Hazard.

Can cause serious injury or death.

Do not let fuel accumulate in the combustion chamber. If fuel is allowed to enter the chamber for longer than a few seconds without igniting, an explosive mixture could result.

CAUTION

Equipment Damage Hazard.

Failure to complete tests can cause equipment damage.

1. Do not put the system into service until you have satisfactorily completed all applicable tests described in the Checkout section of the instructions for the flame safeguard control, and any other tests required by the burner manufacturer.
2. Close all manual fuel shutoff valves as soon as trouble occurs.

Checkout

1. Valve outlet pressure measurements are made at a point approximately five pipe diameters downstream from the valve outlet. Consider pressure measurements made at the outlet pressure tap as reference measurements only, because turbulence and dynamic gas flow effects may result in erratic pressure readings.
2. Shut off gas supply to valve and make sure valve is closed when setting up pressure measuring equipment.
3. Set up pressure measuring equipment.
4. Make sure the valve is closed. Turn on the supply gas to the valve.
5. Set the thermostat or controller to energize the valve and check the final outlet pressure. See step 1. Allow enough time for the system pressure to stabilize.
6. For regulator setpoint and spring range, please refer to Table 3.
7. The low pressure regulator (V4944/V8944B,C,L,N) and high pressure regulator V4943/V8943B,C,N and V4944/V8944B,C,L,N) adjustment screws are located under the slotted aluminum screw cap(s) of the adjustment screw housings (see Fig. 1). To adjust the pressure setting:
 - a. Temporarily remove the slotted aluminum screw cap and gasket from the housing that contains the regulator adjustment setscrew.
 - b. Turn the adjustment setscrew clockwise to increase the pressure setting or counterclockwise to decrease the pressure setting. Allow adequate time (30 to 60 seconds) for the pressure to reach equilibrium between pressure adjustments. A mechanical range stop in the low pressure regulator adjustment of the V4944/V8944B,C,L,N models controls the minimum

setting to which the low pressure regulator can be adjusted. Do not turn the adjusting setscrew counterclockwise beyond the point at which it is stopped by the mechanical range limit.

- c. After the regulators have been properly adjusted, replace the gasket and slotted aluminum screw cap on the adjustment screw housing.
8. Start the system and observe its operation through at least one complete cycle to make sure the valve functions properly.

Valve Leak Test (See Fig. 15).

This test checks the tightness closure of a gas safety shutoff valve. It should be performed by a qualified technician during the initial startup of a burner system, or whenever the valve is replaced (see Service Information section). It is recommended that this test also be included in scheduled inspection and maintenance procedures.

1. De-energize the control system to make sure there is no power to the safety shutoff valve (C) shown in Fig. 15.
2. Close the upstream manual gas cock (A).
3. Make sure the manual test petcock (F) is closed in the leak test tap assembly (D).
4. Remove the leak test tap plug (valve outlet pressure tap can be used as a test tap) and connect the test apparatus to the leak test tap (D).
5. Close the downstream manual gas cock (E).
6. Open the upstream manual gas cock (A).
7. Run the safety shutoff valve (C) to its fully open position (through the safety system); then immediately de-energize the system to close the valve.
8. Immerse a 1/4 in. tube vertically 1/2 in. (13 mm) into a jar of water.
9. Slowly open the test petcock (F).
10. When the rate of bubbles coming through the water stabilizes, count the number of bubbles appearing during a ten-second period. Each bubble appearing during a ten-second period represents a flow rate of approximately 0.001 cfm.

To meet code requirements, leakage must not exceed the values in Table 5.

Table 5. Allowable Leakage Rates.

Pipe Size (in.)	Allowable ^a Leakage	Number of Bubbles per 10 sec.
1, 1-1/4	353	13
1-1/2, 2	453	16

^a Based on air standard conditions, test pressures in accordance with ANSI Z21.21, Section 2.4.2 and a maximum of 235 cc/h per inch of seal-off-diameter. Seal-off diameter is not the same as pipe size.

11. Close the upstream manual gas cock (A).
12. Close the test petcock (F), remove the test apparatus, and replace the leak test tap plug (D).
13. Open the upstream manual gas cock (A) and energize the safety shutoff valve (C).
14. Test with soap bubbles to make sure there is no leak at the test tap (D).
15. De-energize the safety shutoff valve (C).
16. Open the downstream manual gas cock (E).
17. Restore the system to normal operation.

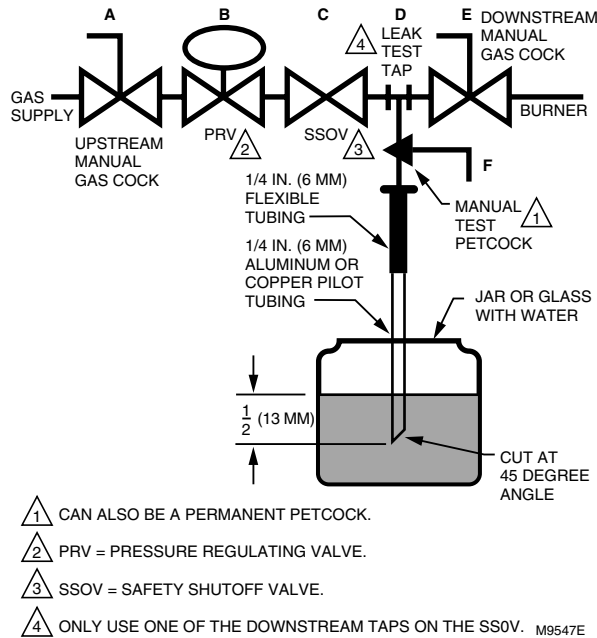

Fig. 15. Valve leak test.

Troubleshooting

! WARNING

Electrical Shock Hazard.

Can cause electrical shock or equipment damage. Use utmost care during troubleshooting. Line voltage is present right at the electrical terminations for the V4943B,C,N and V4944B,C,L,N valves, and present in all controller circuits for all V4943/V8943 and V4944/V8944 valves.

IMPORTANT

Do not assume that the valve must be replaced until all other sources of trouble have been eliminated.

1. If the valve will not open when the thermostat or controller calls for heat:
 - a. Check that there is voltage at the proper electrical terminations. Be careful—there should be line voltage at the actuator of V4943 and V4944 valves.
 - b. If there is no voltage at the actuator, first make sure line voltage power is connected to the master switch, the master switch is closed and overload protection (circuit breaker, fuse or similar device) has not opened the power line.
 - c. For V8943A only: If line voltage power is correct, check transformer output. Replace the transformer if necessary.

- d. If there is still no voltage at the actuator, make sure all appropriate contacts in the thermostat or controller, limits and flame safeguard control are closed. If one or more is open, determine the cause(s) and correct the condition(s) before proceeding.
 - e. If there is proper voltage at the valve actuator but the valve still does not open, first check that the gas pressure at the valve is normal.
 - f. If the valve still does not open, replace the valve.
2. If the valve will not close when one or more of the appropriate contacts in the thermostat or controller, limit(s) or flame safeguard control is open:
 - a. Make sure that the gas flow is in the direction of the arrow on the valve body.
 - b. Make sure the valve actuator is wired in the correct circuit. Open the master switch to remove power from the valve actuator. If the valve closes now, the actuator may not be wired properly. Check and correct the wiring, if necessary.
 - c. Look for a short in the electrical circuit.

SERVICE INFORMATION

! WARNING

Electrical Shock Hazard

Can cause serious injury, death or equipment damage.

1. Only qualified service technicians should attempt to service or repair flame safeguard controls and burner systems.
2. Line voltage is present in the electrical circuits to the valve. Open the master switch before replacing the valve.

Scheduled Inspection and Maintenance

For periodic inspection and maintenance, set up a schedule and follow it. Include the burner valves (check for external leakage around all seals and joints with leak detector; also check for internal valve seat leakage—see Valve Leak Test section) and all other controls. Refer to the flame safeguard control instructions for more information.

! CAUTION

Equipment Damage Hazard.

Can cause equipment damage or improper operation.

Label all wires prior to disconnecting when servicing valves. Wiring errors can cause improper and dangerous operation.

Verify proper operation after servicing.

Automation and Control Solutions

Honeywell International Inc.
1985 Douglas Drive North
Golden Valley, MN 55422
customer.honeywell.com

Honeywell Limited-Honeywell Limitée
35 Dynamic Drive
Scarborough, Ontario M1V 4Z9

