

V5097A-E Industrial Gas Valves

PRODUCT DATA



FEATURES

- Used with natural or liquefied petroleum (LP) gases.
- V5097 normally closed valves are rated for final shutoff service (safety shutoff).
- V5097A,C,D,E Valves are for on-off service.
- V5097B Valve has a characterized guide and in combination with the V4055, V4062 and V9055 Fluid Power Actuators, provides slow-opening, HI-LO-OFF, and modulating functions, respectively.
- V5097C,E Valves have a double seal and are used with V4055D,E Fluid Power Actuators to provide proof-of-closure switch and valve seal overtravel interlock.
- V5097D,E Valves are for high pressure applications (see Table 1).
- Two valve body types (small and large) applicable to seven pipe sizes:
 - Small body type for 3/4 in. (19 mm), 1 in. (25 mm), 1-1/4 in. (32 mm), 1-1/2 in. (38 mm) and 2 in. (51 mm) pipes.
 - Large body type for 2 in. (51 mm), 2-1/2 in. (64 mm) and 3 in. (76 mm) pipes.
- Eight pipe adapter sizes 3/4 in. (19 mm) to 3 in. (76 mm) have NPT or BSP-PL threaded connections.
- V5097 version provides three 1/4 in. upstream and two 1/4 in. downstream taps and plugs. CE version provides an additional downstream tap and plug.
- Valve body rating of 75 psi (5 bar); body passes Underwriters Laboratories Inc. burst test.
- Yellow SHUT indicator attached to the valve stem provides indication of the valve closed position.
- Unpainted die-cast aluminum body.

APPLICATION

The V5097A-E Gas Valves are used with the V4055, V4062 and V9055 Fluid Power Actuators to control gas flow to commercial and industrial burners.

Contents

Application	1
Features	1
Specifications	2
Ordering Information	2
To Size Two Identical Valves Piped In Series	6
Installation	7
Operation and Checkout	8
Service information	9



SPECIFICATIONS

IMPORTANT

The specifications in this publication do not include normal manufacturing tolerances; therefore, an individual unit may not exactly match the specifications listed. Also, this product is tested and calibrated under closely controlled conditions, and some minor differences in performance can be expected if those conditions are changed.

Models: See Table 1.

Table 1. Industrial Gas Valve Models:

Model Number	Features
V5097A	Low pressure on-off (with quick-opening guide).
V5097B	Low pressure characterized guide (provides slowly increasing gas flow on opening). For slow-opening, high-low-off, or modulating service.
V5097C	Low pressure double-seat. Used with V4055D, V4062D, V9055D Actuators to provide proof-of-closure switch and a valve seal overtravel interlock.
V5097D	High pressure on-off (with quick-opening guide).
V5097E	High pressure double-seat. Used with V4055D, V4062D, V9055D Actuators to provide proof-of-closure switch and a valve seal overtravel interlock.

Type of Gas: Natural or liquefied petroleum (LP) only.

Pipe Size:

Small Body: 3/4 in. (19 mm); 1 in. (25 mm); 1-1/4 in. (32 mm); 1-1/2 in. (38 mm); 2 in. (51 mm).

Large Body: 2 in. (51 mm); 2-1/2 in. (64 mm); 3 in. (76 mm).

Pipe Threads:

NPT or BSP-PL threads (equivalent to ISO R7 and DIN 2999). Available 3/4 in. to 3 in. pipe adapters. (Order separately.)

Pressure Ratings: See Table 2.

Valve Body Rating: 75 psi (5 bar); body passes burst test of Underwriters Laboratories Inc.

Valve Capacities: IAS ratings at 1 in. (0.25 kPa) pressure drop; based on gas with 0.64 sp gr.

Bolt/Nut Fasteners:

Small Body:

3/8-16 x 1.375, Grade 5 bolt. Metric equivalent M8 x 1.25 x 35mm, class 9.8.

Large Body:

1/2-13 x 2.00, Grade 5 bolt. Metric equivalent M12 x 1.75 x 50mm, class 9.8.

Pipe Adapter Ratings: See Table 3.

Gas Pressure Limit Switch Mounting: Two 1/4 in. NPT or BSP-PL upstream and downstream tapping and plug.

Upstream Tapping and Plug: 1/4 in. NPT or BSP-PL.

Downstream Tapping and Plug: 1/4 in. NPT.

Ambient Operating Temperature Rating: -40°F to +150°F (-40°C to +66°C); -40°F to +125°F (-40°C to +52°C) when used with V9055.

Material: Die-cast aluminum.

Mounting: Directly in gas supply line.

Dimensions: See Fig. 1 and 2.

Weight:

Small Body Valve: 3.68 lb (1.67 kg).

Large Body Valve: 8.0 lb (3.64 kg).

Small Body Pipe Adapters: .67 lb (0.3 kg).

Large Body Pipe Adapters: 2.125 lb (.97 kg).

Replacement Parts:

133393A Replacement Seal Assembly (Includes valve seal, bonnet seal and tube of lubricant) for Small Body Valves.

133392A Replacement Seal Assembly (Includes valve seal, bonnet seal and tube of lubricant) for Large Body Valves.

For all pipe adapter sizes, see Table 3.

Replacement Bonnet Assembly (Table 4):

Includes complete bonnet assembly, plus the required replacement seal assembly.

Accessories:

133637 Tube of lubricant (supplied).

DSP3556 Valve Assembly Tool (UVG).

ORDERING INFORMATION

When purchasing replacement and modernization products from your TRADELINE® wholesaler or distributor, refer to the TRADELINE® Catalog or price sheets for complete ordering number.

If you have additional questions, need further information, or would like to comment on our products or services, please write or phone:

1. Your local Honeywell Automation and Control Products Sales Office (check white pages of your phone directory).
2. Honeywell Customer Care
1885 Douglas Drive North
Minneapolis, Minnesota 55422-4386

In Canada—Honeywell Limited/Honeywell Limitée, 35 Dynamic Drive, Scarborough, Ontario M1V 4Z9.

International Sales and Service Offices in all principal cities of the world. Manufacturing in Australia, Canada, Finland, France, Germany, Japan, Mexico, Netherlands, Spain, Taiwan, United Kingdom, U.S.A.

4074EYE Bag Assembly, contains 6 bolts, nuts and lock washers for Large Body Valves and adapters.
 4074EYF Bag Assembly, contains 6 bolts, nuts and lock washers for Small Body Valves and adapters.

4074EYK Bag Assembly, contains 2 O-rings and tube of lubricant—small body.
 4074EYL Bag Assembly, contains 2 O-rings and tube of lubricant—large body.

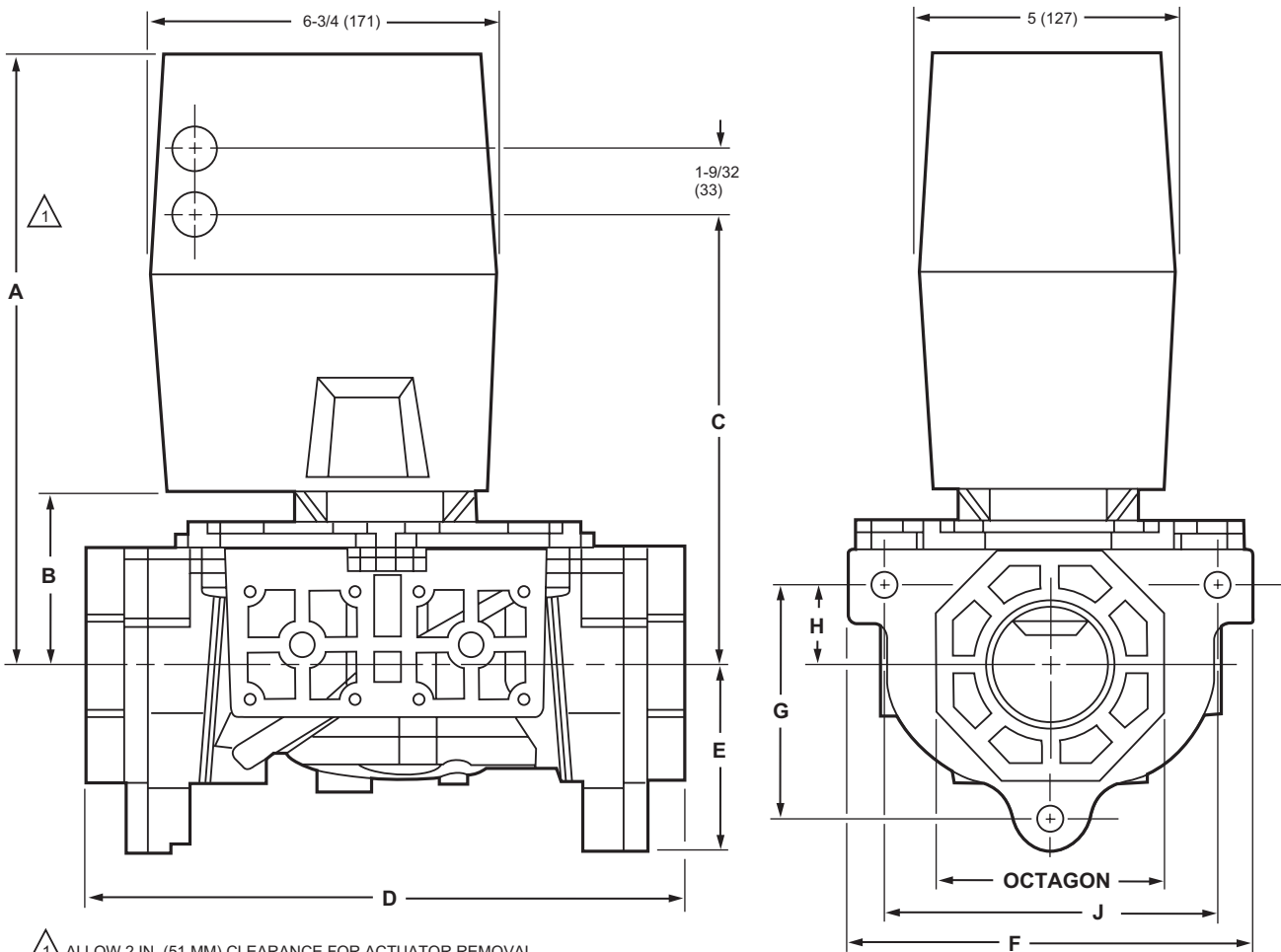

1 ALLOW 2 IN. (51 MM) CLEARANCE FOR ACTUATOR REMOVAL.

VALVE SIZE (IN.)	DIM. A		DIM. B		DIM. C		DIM. D		DIM. E		DIM. F		DIM. G		DIM. H		DIM. J		OCTAGON	
	IN.	MM	IN.	MM	IN.	MM	IN.	MM	IN.	MM	IN.	MM	IN.	MM	IN.	MM	IN.	MM	IN.	MM
3/4	11-1/8	283	2-3/4	70	8-3/16	208	8-1/4	210	2-7/16	62	5	127	2-5/16	58	7/8	23	3-15/16	100	2-13/16	71
1	11-1/8	283	2-3/4	70	8-3/16	208	8-1/4	210	2-7/16	62	5	127	2-5/16	58	7/8	23	3-15/16	100	2-13/16	71
1-1/4	11-1/8	283	2-3/4	70	8-3/16	208	8-1/4	210	2-7/16	62	5	127	2-5/16	58	7/8	23	3-15/16	100	2-13/16	71
1-1/2	11-1/8	283	2-3/4	70	8-3/16	208	8-1/4	210	2-7/16	62	5	127	2-5/16	58	7/8	23	3-15/16	100	2-13/16	71
2	11-3/4	298	3-3/8	86	8-5/16	211	11-3/4	298	3-5/8	91	8	203	4-7/16	113	1-1/2	38	6-1/2	165	4-1/2	114
2-1/2	11-3/4	298	3-3/8	86	8-5/16	211	11-3/4	298	3-5/8	91	8	203	4-7/16	113	1-1/2	38	6-1/2	165	4-1/2	114
3	11-3/4	298	3-3/8	86	8-5/16	211	11-3/4	298	3-5/8	91	8	203	4-7/16	113	1-1/2	38	6-1/2	165	4-1/2	114

M11682A

Fig. 1. Approximate dimensions of 3/4 in. through 3 in. V5097 Valves with valve actuator, in inches and millimeters.

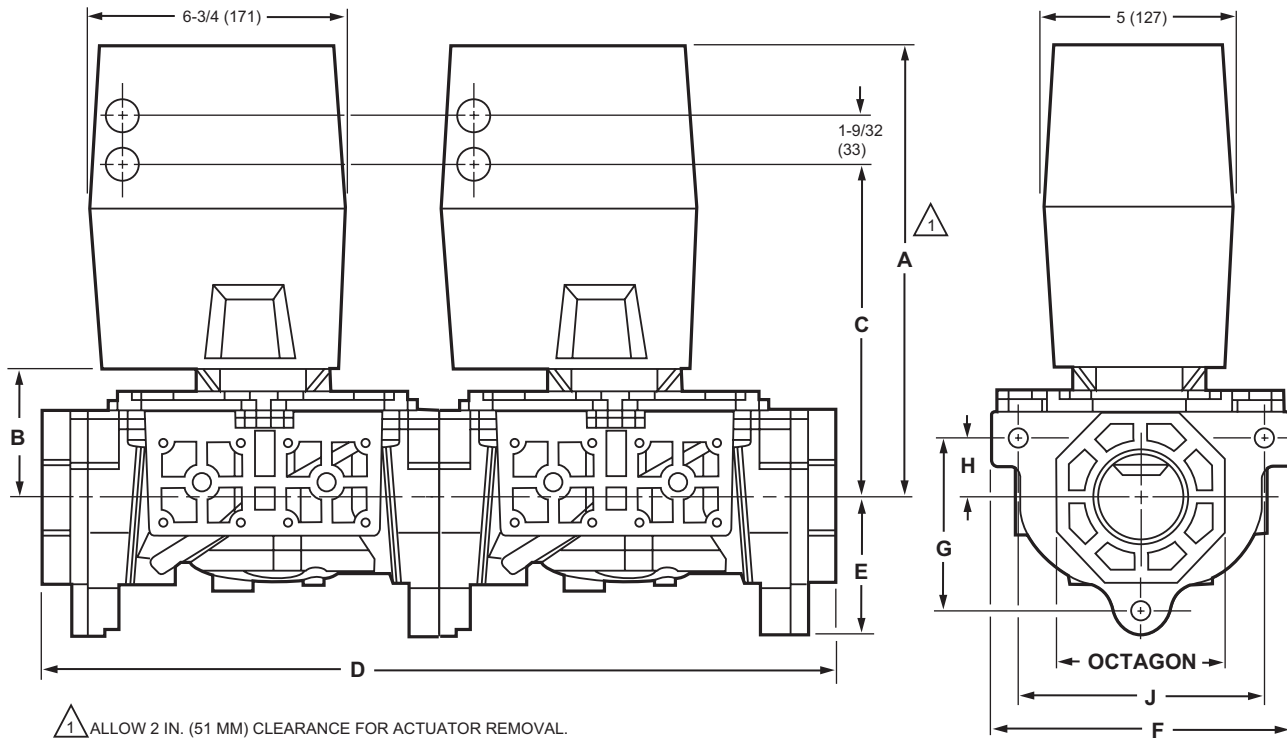

VALVE SIZE (IN.)	DIM. A		DIM. B		DIM. C		DIM. D		DIM. E		DIM. F		DIM. G		DIM. H		DIM. J		OCTAGON	
	IN.	MM	IN.	MM	IN.	MM	IN.	MM	IN.	MM	IN.	MM	IN.	MM	IN.	MM	IN.	MM	IN.	MM
3/4	11-1/8	283	2-3/4	70	8-3/16	208	14	210	2-7/16	62	5	127	2-5/16	58	7/8	23	3-15/16	100	2-13/16	71
1	11-1/8	283	2-3/4	70	8-3/16	208	14	210	2-7/16	62	5	127	2-5/16	58	7/8	23	3-15/16	100	2-13/16	71
1-1/4	11-1/8	283	2-3/4	70	8-3/16	208	14	210	2-7/16	62	5	127	2-5/16	58	7/8	23	3-15/16	100	2-13/16	71
1-1/2	11-1/8	283	2-3/4	70	8-3/16	208	14	210	2-7/16	62	5	127	2-5/16	58	7/8	23	3-15/16	100	2-13/16	71
2	11-3/4	298	3-3/8	86	8-5/16	211	21	298	3-5/8	91	8	203	4-7/16	113	1-1/2	38	6-1/2	165	4-1/2	114
2-1/2	11-3/4	298	3-3/8	86	8-5/16	211	21	298	3-5/8	91	8	203	4-7/16	113	1-1/2	38	6-1/2	165	4-1/2	114
3	11-3/4	298	3-3/8	86	8-5/16	211	21	298	3-5/8	91	8	203	4-7/16	113	1-1/2	38	6-1/2	165	4-1/2	114

M11683A

Fig. 2. Approximate dimensions of two small and large V5097 Valves with valve actuators and pipe adapters in inches and millimeters.

Table 2. V5097 Models.

Model	Pipe Size (in. NPT)	Standard Pressure Actuators V4055A,D, V40652, V9055						High Pressure Actuators V4055B,E					
		MOPD ^a		MOP ^b		MCOP ^c		MOPD ^a		MOP ^b		MCOP ^c	
		psi	mbar	psi	mbar	psi	bar	psi	bar	psi	bar	psi	bar
Standard Pressure Valves V5097A,B,C	3/4 to 2	5	340	15	1000	15	1	15	1	15	1	15	1
	2 to 3			13	880								
High Pressure Valves V5097D,E	3/4 to 2	5	340	40	2700	75	5	25	1.6	62	4	75	5
	2 to 3			13	880	45	3	15	1	21	1.4	45	3

^a Maximum operating pressure differential. Once open, the valve and actuator operate correctly against this pressure at 85% of rated voltage.

^b Maximum opening pressure. Actuator opens valve against this pressure at 85% of rated voltage.

^c Maximum close-off pressure. Maximum allowable pressure drop across fully closed valve prevents seal leakage (independent of 75 psi valve body rating).

Approvals:

Underwriters Laboratories Inc. Listed: File MH1639, Guide

No. Y102:

V4055A,B,D,E/V5097A,B,C,D,E.

V4062/V5097A,B,C,E.

V9055/V5097A,B,C,E.

Industrial Risk Insurers (Formerly FIA) Acceptable:

V4055A,B,D,E/V5097A,B,C,D,E.

V9055/V5097A,B,C,E.

Factory Mutual Approved: All.

International Approval Services (IAS) Design Certified: Report

No. 21-1C:

V4055A/V5097A,B.

V4055B/V5097D.

V4055DV5097C.

V4055E/V5097E.

V4062/V5097B,C.

V9055/V5097B,C.

NOTE: IAS does not certify models equipped with BSP threads.

International Approval Services (IAS) Certified (60 Hz

Actuator Models Only): Report No. 1029-SSV-4098:

V4055A,B,D,E/V5097A,B,C,D, E.

V4062/V5097B.

V9055/V5097B.

CE Approved: CE-0063AR1359 (V5097A1020, V5097A1038,

V5097B1028, V5097B1036 Only).

Australian Gas Association Approved (Pending).

Table 3. Valve Plus Two Pipe Adapters Ratings.

Adapter Part Number	Size (in.)	CSA Rated Capacity	
		(cfh)	(cu m/hr)
32000109-001	3/4 NPT	665	18.8
32000109-002	1 NPT	960	27.2
32000109-003	1-1/4 NPT	1406	39.8
32000109-004	1-1/2 NPT	1717	48.6
3200109-005	2 NPT (Small Body)	1990	56.9
32001605-001	2 NPT (Large Body)	3620	102.5
32001605-002	2-1/2 NPT	4250	120.3
32001605-003	3 NPT	5230	148.1
32000109-006	3/4 BSP	665	18.8
32000109-007	1 BSP	960	27.2
32000109-008	1-1/4 BSP	1406	39.8
32000109-009	1-1/2 BSP	1717	48.6
32001605-004	2 BSP (Large Body)	3620	102.5
32001605-005	2-1/2 BSP	4250	120.3
32001605-006	3 BSP	5230	148.1

Table 4. Replacement Bonnet Assemblies.

Valve Model	Pipe Adapter Size (in. NPT)	Replacement Bonnet Assembly (part no.)
V5097A1004 (On-Off)	3/4, 1, 1-1/4, 1-1/2, 2 (small)	133398AA
V5097A1012	2, 2-1/2, 3 (large)	133417AA
V5097B1002 (Characterized guide)	3/4, 1, 1-1/4, 1-1/2, 2 (small)	133398BA
V5097B1010	2, 2-1/2, 3 (large)	133417BA
V5097C1000	3/4, 1, 1-1/4, 1-1/2, 2 (small)	133398CA
V5097C1018	2, 2-1/2, 3 (large)	133417CA
V5097D1008	3/4, 1, 1-1/4, 1-1/2, 2 (small)	136308AA
V5097D1016	2, 2-1/2, 3 (large)	136307AA
V5097E1005	3/4, 1, 1-1/4, 1-1/2, 2 (small)	136308BA
V5097E1013	2, 2-1/2, 3 (large)	136307BA

Gas Valve Sizing

Honeywell gas valve capacities are shown in cubic feet per hour (cfh) or cubic meters per hour (m³h) for gas with a specific gravity of 0.64 (1 cfh = 0.0283 m³h).

1. Check the burner nameplate for (a) the type of gas used, and (b) the gas flow capacity (listed in Btuh or in cfh).
2. Call the gas utility for information on (a) sp gr and (b) Btu/cu ft for type of gas used.
3. If the capacity is listed in Btuh, convert to cfh using the following formula:
Capacity in cfh = $\frac{\text{Btuh (from burner nameplate)}}{\text{Btu/cf (from gas utility)}}$

4. For gases with specific gravities other than 0.64, correct the cfh from the nameplate or from the formula in step 3 for the specific gravity of gas used, following the information in Fig. 3.
5. Use the cfh capacity (for 0.64 or the corrected cfh from step 4) for determining the gas valve size in Fig. 4.
6. Determine the maximum pressure drop across the valve and draw a horizontal line at this pressure in Fig. 4.
7. Draw a vertical line in Fig. 4 at the capacity (cfh) previously determined. Use the corrected capacity for a gas with a specific gravity other than 0.64.
8. Use the valve size at the intersection of the horizontal and vertical lines. If the intersection is between valve sizes, use the next larger valve size in Fig.4.

TO SIZE TWO IDENTICAL VALVES PIPED IN SERIES

1. Find the cf/h for the type of gas used.
2. Consider both valves as one unit. Determine the total maximum pressure drop across the unit.
3. Find the pressure drop across the first valve by assuming it to be 45 percent of the total pressure drop.
4. Find the valve size from Fig. 1.
5. The second valve will be the same size as the first valve.

How to use the Specific Gravity Conversion Factors (Fig. 3)

Listed valve capacity ratings are based on 0.64 specific gravity (sg gr) gas. When the required cfh capacity is known for gas of other specific gravity, it can be converted to the 0.64 equivalent by using the correct multiplying factor obtained from Fig. 3.

For example, a valve capacity of 2670 cfh based on 0.72 sp gr gas is required. What valve capacity, based on 0.64 sp gr gas, will be required?

On the vertical scale of Fig. 3, find 0.72 specific gravity (left side of figure). Draw a line horizontally from that point to the right to intersect the curve, then move straight down the chart to the bottom scale and read the conversion factor (1.06, in this example).

Multiply the 2670 cfh by the conversion factor (1.06) to obtain a valve capacity of 2830 cfh.

Applying this number to Fig. 4, assuming a 1 in. wc pressure drop, use a 2 in. (large body) V5097 Valve for that flow (step 8 of Gas Valve Sizing).

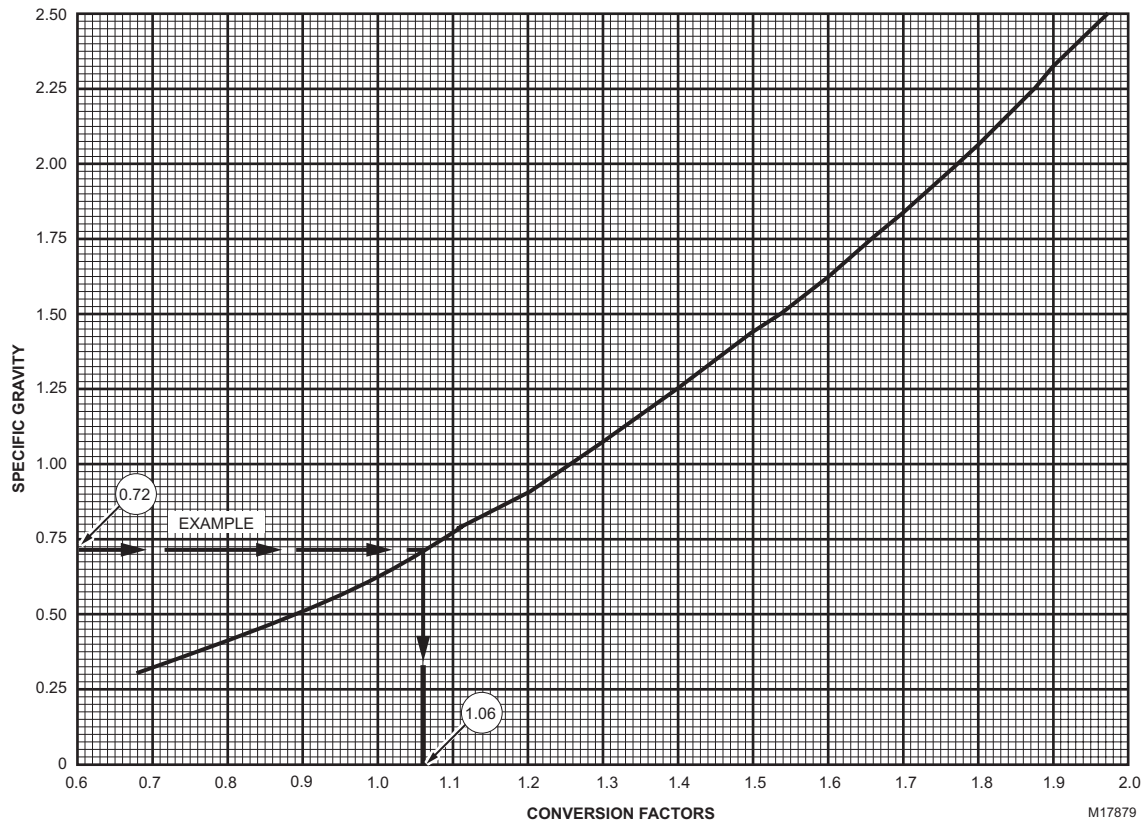

Fig. 3. Specific gravity conversion factors.

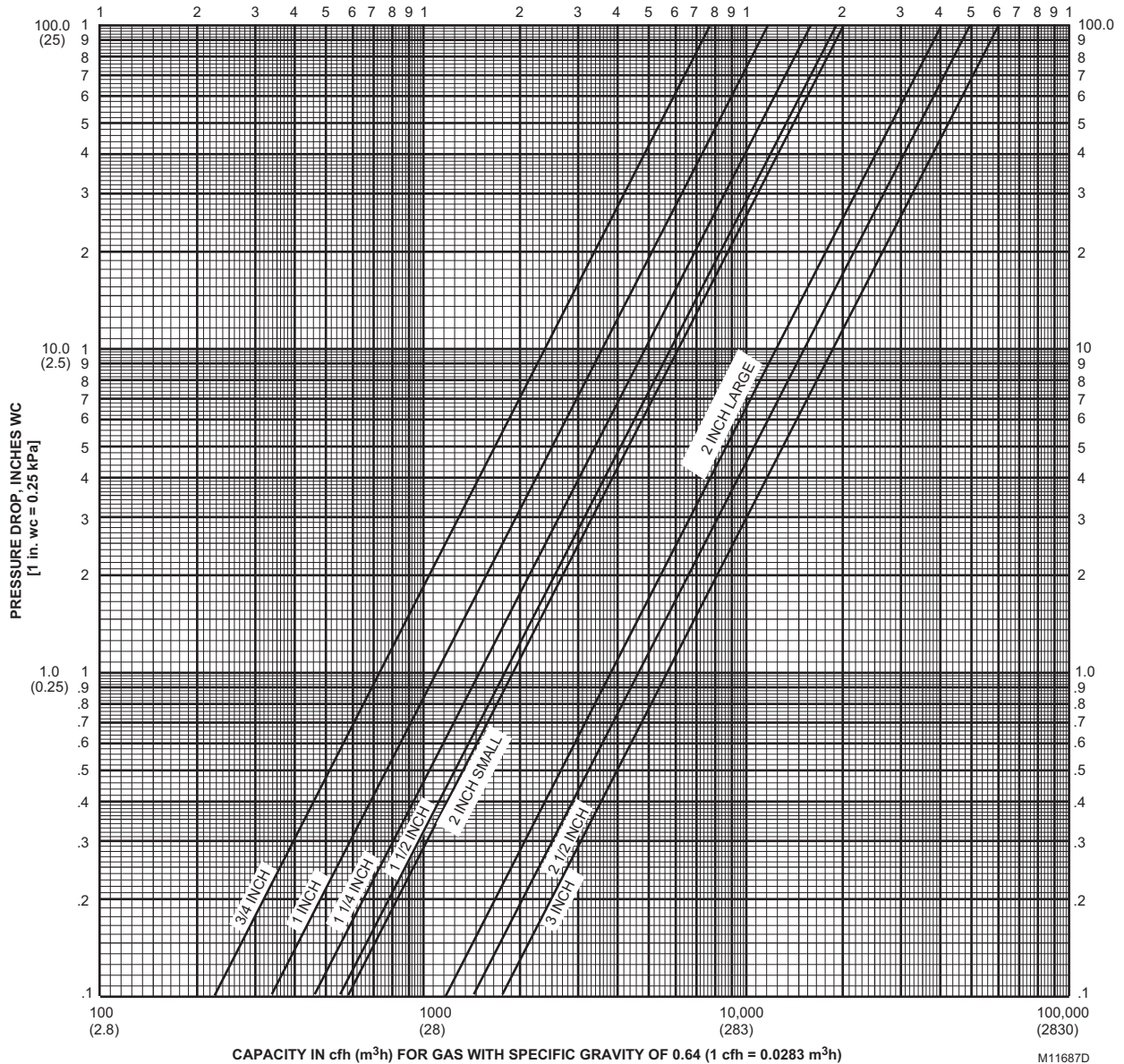

Fig. 4. Flow curves for V5097 valves.

INSTALLATION

IMPORTANT

The V5097 Valve is designed to provide control of gaseous fuel (natural and LP gas) flow in applications with minimum water exposure. V5097 Valves used in maritime, beverage, food processing, outdoor or other installations with occasional exposure to water can develop valve stem and spring corrosion, decreasing the operating life of the valve. Inspect V5097 Valves used in these installations annually and replace the valve bonnets when corrosion is noted.

A valve actuator with a NEMA 4 rating is recommended for these installations because the

water-tight design of the NEMA 4-rated actuator prevents water from entering the valve stem and spring chamber through the actuator. Under certain conditions, some water can be retained in the external upper portion of the valve body. The retained water is effectively excluded from the valve stem and spring chamber by a functional seal that is incorporated into the NEMA 4-rated actuator.

When Installing this Product...

1. Read these instructions carefully. Be sure to carefully follow Warning information.
2. Check the ratings given in the instructions and on the product to make sure the product is suitable for your application.

3. Installer must be a trained, experienced flame safeguard control technician.
4. After installation is complete, check out product operation as provided in these instructions.

WARNING

Explosion Hazard And Electrical Shock Hazard. Can cause explosion, serious injury or death.

1. Turn off gas supply before starting installation.
2. Disconnect power supply for valve actuator before beginning installation.
3. Install the valve so the arrow on the valve body points in the gas flow direction.

Location

1. Install the valve in the gas supply line downstream from the pressure regulator.
2. Mount the valve and actuator in any position that allows sufficient clearance for installation and for repair and replacement.
3. Be sure the valve position indicators are easily visible with the valve and actuator in the final position.
4. Ensure the final position of the valve and actuator allows for damper linkage, if used.

IMPORTANT

Allow space for turning the valve body and pipe adapter (actuator not attached) onto the gas piping. Swing dimensions measured from the center of the pipe for 3/4 in. through 2 in. (small) valves are 3-1/4 in. (83 mm) and for 2 in. through 3 in. (large) valves are 5 in. (127 mm).

WARNING

Explosion Hazard. Can cause serious injury or death.

1. Make sure gas flow is in the direction of the arrow on the valve body so the valve shuts off.
2. Do not use valve in a corrosive environment or the valve may not shut completely.

IMPORTANT

Use only the three Grade 5 (minimum) bolts or metric equivalent with split washers (supplied with valve) secured and fastened to ensure gas-tight seal. Use all six bolts.

Installation

Installation instructions are found in form 66-1099, Integrated Valve Train Assembly Instructions.

OPERATION AND CHECKOUT

Operation

A V5097 Industrial Gas Valve is operated by a V4055, V4062 or V9055 Fluid Power Gas Valve Actuator. The valve opens when the actuator is energized, and closes when power is

removed. When closed, the valve seals off against the rated close-off pressure with no power applied. For further information, refer to the actuator instructions.

Checkout

WARNING

Explosion Hazard And Electrical Shock Hazard. Can cause explosion, serious injury or death.

Do not allow fuel to accumulate in the combustion chamber for longer than a few seconds without igniting to prevent an explosive mixture from accumulating.

WARNING

Explosion Hazard. Can cause serious injury or death.

1. Do not put the system into service until you have satisfactorily completed the following Valve Leak Test, all applicable tests described in the Checkout section of the instructions for the flame safeguard control, and any other tests required by the burner manufacturer.
2. All tests must be performed by a trained, experienced flame safeguard control technician.
3. Close all manual fuel shutoff valves as soon as trouble occurs.

After the installation is completed, cycle the valve several times with the manual fuel shutoff cock closed. Make sure the valve and actuator function properly. Also perform the Valve Leak Test before putting the valve into service.

Valve Leak Test (Fig. 5)

This is a test for checking the closure tightness of the gas safety shutoff valve. It should be performed only by trained experienced flame safeguard control technicians during the initial startup of the burner system, or whenever the valve or valve bonnet is replaced (see Service Information section). It is recommended that this test also be included in the scheduled inspection and maintenance procedures. For a periodic inspection test, follow steps 1, 3, 4, 5, 8, 9, 10, 12, 13, 16, and 17.

1. De-energize the control system to assure no power goes to the valve actuator (C, Fig. 5).
2. Close the upstream manual gas cock (A).
3. Make sure the manual test petcock (F) is closed in the leak test tap assembly (D).
4. Remove the leak test tap plug and connect the test apparatus to the leak tap (D).
5. Close the downstream manual gas cock (E).
6. Open the upstream manual gas cock (A).
7. Run the V5097 Valve to its fully open position (through the safety system); then immediately de-energize the system to close the V5097 Valve.
8. Immerse a 1/4 in. (6 mm) tube vertically 1/2 in. (13 mm) into a jar of water.
9. Slowly open the test petcock (F).
10. When the rate of bubbles coming through the water stabilizes, count the number of bubbles appearing during a ten-second period or note the time required for ten bubbles. Each bubble appearing represents a flow rate of 0.001 cfh.

To meet US requirements, be sure leakage does not exceed the rates in Table 5.

Table 5. V5097 Valve Allowable Leakage Rate.

V5097 Pipe Adapter Size (in.)	Medium	Allowable Leakage SCCH	Maximum No. of Bubbles in 10 sec.)	Minimum No. of Seconds for 10 bubbles
3/4, 1, 1-1/4, 1-1/2, 2	0.64 gas	573	14	6.7
	1.00 air ^a	458	9	10.2
	1.57 LP	366	9	10.5
2, 2-1/2, 3	0.64 gas	940	24	4.1
	1.00 air ^a	752	16	6.2
	1.57 LP	602	15	6.4

^a Based on air at standard conditions, test pressures provided by ANSI Z21.21, Section 2.42 and a maximum of 235 cc/h/in. of seal-off diameter (not pipe size).

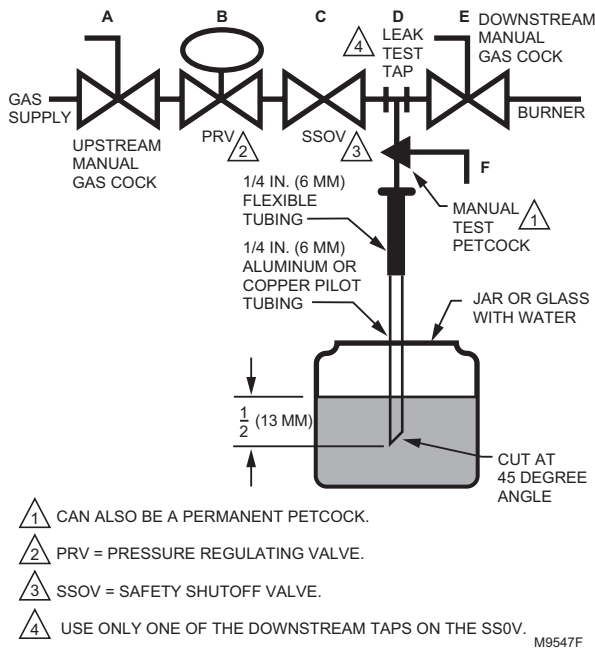

Fig. 5. Valve leak test.

NOTE: For international leak test requirements, contact the appropriate approval agency.

After the Test

1. Close the upstream manual gas cock (A).
2. Close the test petcock (F), remove the test apparatus, and replace the leak test tap (D).

3. Open the upstream manual gas cock (A) and energize the V5097 Valve actuator through the safety system.
4. Test with rich soap and water solution to make sure there is no leak at the test tap (D) or any pipe adapter/valve mating surfaces.
5. De-energize the V5097 Valve (C).
6. Open the downstream manual gas cock (E).
7. Restore the system to normal operation. If two safety shutoff valves are used, check each V5097 Valve for closure tightness.

SERVICE INFORMATION

⚠ WARNING

Explosion Hazard And Electrical Shock Hazard. Can cause explosion, serious injury or death.

1. Turn off the gas supply and disconnect all electrical power to the valve actuator before servicing.
2. Properly position and seat the seals in the valve body to prevent a hazardous gas leak.
3. Do not disassemble the valve bonnet assembly because the valve seat is not replaceable.

IMPORTANT

Only trained, experienced flame safeguard control technicians should attempt to service or repair flame safeguard controls and burner assemblies.

Scheduled Inspection and Maintenance

Set up and follow a schedule for periodic inspection and maintenance for the burner, all other controls, and the valve(s). It is recommended that the valve leak test in the Operation and Checkout section be included in this schedule. Refer to the instructions for the primary safety control for more information.

Valve Bonnet Replacement

The entire valve bonnet can be replaced without removing the valve body from the gas line. Do not disassemble the valve bonnet assembly because the valve seat is not replaceable.

For part numbers, refer to Replacement Parts in the Specifications section. Complete instructions for replacing the bonnet assembly are included with the replacement part.

Seal Assembly Replacement (Fig. 6)

When removing the bonnet to inspect and clean the valve, install new seal assemblies (see Replacement Parts in the Specification section). Coat the new seals with the grease provided and insert them in the valve body as shown in Fig. 6.

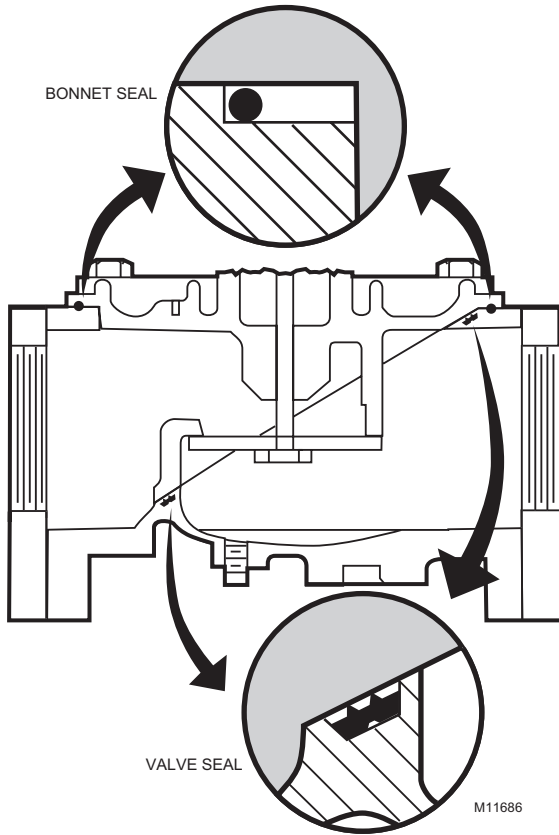

Fig. 6. Proper positions of valve and bonnet seals in V5097 Valves.

Failure to properly position and seat the seals in the valve body can result in a hazardous gas leak.

After the new bonnet assembly is installed or the bonnet is removed for any reason, check for gas leakage around the bonnet seal. Turn on the gas at the manual valve. Paint the seal area with a rich soap and water solution. Bubbles indicate a gas leak. If a leak is detected, check that the bonnet screws are tight. If necessary, turn off the gas again and remove the bonnet to make sure the seals are properly seated.

Honeywell

Automation and Control Solutions

Honeywell International Inc.
1985 Douglas Drive North
Golden Valley, MN 55422

Honeywell Limited-Honeywell Limitée
35 Dynamic Drive
Scarborough, Ontario
M1V 4Z9

Honeywell International

Control Products
Honeywell Building
17 Changi Business Park Central 1
Singapore 486073

Honeywell Europe S.A.

3 Avenue du Bourget
1140 Brussels
Belgium

Honeywell Latin American Region

480 Sawgrass Corporate Parkway
Suite 200
Sunrise FL 33325

