

## EC7810A, EC7820A 7800 SERIES Relay Modules

### INSTALLATION INSTRUCTIONS

## APPLICATION

The Honeywell EC7810, EC7820 is a microprocessor-based integrated burner control for automatically fired gas, oil, or combination fuel single burner atmospheric (EC7810A) or atmospheric with fan (EC7820A) applications. The EC7810, EC7820 Relay Module system consists of a relay module, wiring subbase, amplifier, and purge card. Options include personal computer interface, keyboard display module (KDM), Data ControlBus Module™, remote display mounting and Combustion System Manager® Software. Functions provided by the relay modules include automatic burner sequencing, flame supervision, system status indication, system or self-diagnostics and troubleshooting.

This document provides installation and static checkout instructions. Other applicable publications are:

- 65-0084 Q7800A,B 22-Terminal Wiring Subbase Product Data.
- 65-0089 ST7800A Plug-In Purge Timer Installation Instructions.
- 65-0090 S7800A Keyboard Display Module Product Data.
- 65-0091 S7810A Data ControlBus Module™ Product Data.
- 65-0095 S7820 Remote Reset Module Product Data.
- 65-0097 221729C Dust Cover Packing Sheet.
- 65-0102 ZM7850A Combustion System Manager® Operating Instructions.
- 65-0109 R7824, R7847, R7848, R7849, R7851, R7861, R7886 Flame Amplifiers for the 7800 SERIES Product Data.
- 65-0131 221818A Extension Cable Assembly Product Data.
- 65-0229 7800 SERIES Relay Modules Checkout and Troubleshooting Product Data.
- 65-0249 ModBus Module (S7810M1029 only).

## SPECIFICATIONS

### Electrical Ratings, See Tables 4 and 5:

Voltage and Frequency: 220-240 Vac (+10/-15%),  
50/ 60 Hz (±10%).

Power Dissipation: 10W maximum.

Maximum Total Connected Load: 2000 VA.

Fusing Total Connected Load: 15A maximum, type SC  
or equivalent.

### Environmental Ratings:

Ambient Temperature:

Operating: -40°F to 140°F (-40°C to 60°C).

Storage: -40° F to 150° F (-40°C to +66°C).

Humidity: 85% relative humidity continuous, noncondensing.

Vibration: 0.5G environment.

### Approvals:

Factory Mutual Approved: Report No. J.I.1.0Y0A9.AF.

IRI: Acceptable.

Federal Communications Commission: Part 15, Class B,  
Emissions.

### European Directives:

Gas Appliance Directive: 90/269/EEC.

Low Voltage Directive: 73/23/EEC.

EMC Directive: 89/336/EEC.

GASTEC: CE-63AP3070/1.

Approved according to EN298, "Automatic gas burner systems for gas burners and gas burning appliances with or without fans.

### Oil Approvals:

EC7810A1027: DIN-5F 104/96.

EC7820A1026: DIN-5F 105/96.

### IMPORTANT

*To comply with EN60730 for remote mounting of the display and/or remote reset, provide electrical separation using insulation at least equivalent to double or use reinforced insulation. Accomplish this by optically isolating the communication and/or remote reset lines from the control cabinet, or providing physical separation from the communication and/or remote reset lines using electrical conduit and part number 204718A Remote Display Cover Assembly or other suitable enclosure that meets IP40 class of protection.*



**IMPORTANT**

A Flame Detection System is required for operation and must be ordered separately. Select the applicable Flame Signal Amplifier and matching Flame Detector from form number 65-0109.

## INSTALLATION

### When Installing this Product...

1. Read these instructions carefully. Failure to follow them could damage the product or cause a hazardous condition.
2. Check the ratings given in the instructions and marked on the product to make sure the product is suitable for the application.
3. Installer must be a trained, experienced, flame safeguard service technician.
4. After installation is complete, check out the product operation as provided in these instructions.

### **WARNING**

**Explosion or Fire Hazard.**  
Can cause severe injury, death or property damage.

Observe applicable local safety requirements each time a control is installed on a burner.

### **WARNING**

**Electrical Hazard or Equipment Damage Hazard.**  
Can cause electrical shock or equipment and control damage.

Disconnect the power supply before beginning installation. More than one power supply disconnect may be required.

**IMPORTANT**

1. *Wiring connections for the relay modules are unique; refer to Fig. 5 and 6 or the correct Specifications for proper subbase wiring.*
2. *Wiring must comply with all applicable codes, ordinances and regulations.*
3. *Wiring must comply with NEC Class 1 (Line Voltage) wiring.*
4. *Loads connected to the 7800 SERIES Relay Module must not exceed those listed on the 7800 SERIES Relay Module label or the Specifications; see Tables 4 and 5.*
5. *Limits and interlocks must be rated to simultaneously carry and break current to the ignition transformer, pilot valve, and main fuel valve(s).*
6. *All external timers must be listed or component recognized by authorities who have proper jurisdiction.*
7. *For on-off gas-fired systems, some authorities who have jurisdiction prohibit the wiring of any limit or operating contacts in series between the flame safeguard control and the main fuel valve(s).*

8. *Two Flame Detectors can be connected in parallel with the exception of C7015 Infrared Flame Detectors.*
9. *This equipment generates, uses and can radiate radio frequency energy and, if not installed and used in accordance with the instructions, can cause interference with radio communications. It has been tested and found to comply with the limits for a Class B computing device of Part 15 of FCC rules, which are designed to provide reasonable protection against such interference when operated in a commercial environment. Operation of this equipment in a residential area may cause interference; in which case, the users at their own expense may be required to take whatever measures are required to correct this interference.*
10. *This digital apparatus does not exceed the Class B limits for radio noise for digital apparatus set out in the Radio Interference Regulations of the Canadian Department of Communications.*

See Fig. 1 and 2 for the internal block diagrams of the EC7810A and EC7820A Relay Modules.

### Location

#### Humidity

Install the relay module where the relative humidity never reaches the saturation point. The relay module is designed to operate in a maximum 85 percent relative humidity continuous, noncondensing, moisture environment. Condensing moisture may cause a safety shutdown.

#### Vibration

Do not install the relay module where it could be subjected to vibration in excess of 0.5G continuous maximum vibration.

#### Weather

The relay module is not designed to be weather tight. When installed outdoors, the relay module must be protected by an approved weather-tight enclosure.

### Mounting Wiring Subbase

See Fig. 1 and 2 for the internal block diagrams of the relay modules.

1. Mount the subbase in any position except horizontally with the bifurcated contacts pointing down. The standard vertical position is recommended. Any other position decreases the maximum ambient temperature rating.
2. Select a location on a wall, burner or electrical panel. The Q7800 can be mounted directly in the control cabinet. Be sure to allow adequate clearance for service, installation, access or removal of the 7800 SERIES Relay Module, KDM, flame amplifier, flame amplifier signal voltage probes, Run/Test Switch, electrical signal voltage probes and electrical field connections.
3. For surface mounting, use the back of the subbase as a template to mark the four screw locations; then drill the pilot holes.
4. Securely mount the subbase using four no. 6 screws.

## Wiring Subbase

### WARNING

**Electrical Shock or Equipment Damage Hazard.**  
**Can cause personal injury or equipment and control damage.**

Disconnect all power supplies before beginning installation.

1. For proper subbase wiring, refer to Fig. 5 or 6.
2. For proper remote wiring of the KDM, refer to the Specifications for the KDM (65-0090), Network Interface Unit (63-2278), Data ControlBus Module™ (65-0091) or Extension Cable Assembly (65-0131).
3. Disconnect the power supply from the main disconnect before beginning installation to prevent electrical shock and equipment damage. More than one disconnect may be required.
4. All wiring must comply with all applicable electrical codes, ordinances and regulations. Where required, wiring must comply with NEC, Class 1 (Line Voltage) wiring.
5. For recommended wire size and type, see Table 1.
6. For recommended grounding practices, see Table 2.
7. Use recommended wire routing of leadwires:
  - a. Do not run high voltage ignition transformer wires in the same conduit with the flame detector, Data ControlBus Module™, or Remote Reset Module wiring.
  - b. Do not route flame detector, Data ControlBus Module™, or Remote Reset Module leadwires in conduit with line voltage circuits.

- c. Enclose flame detector leadwires without armor cable in metal cable or conduit.
- d. Follow directions in the flame detector, Data ControlBus Module™, or Remote Reset Module Instructions.

8. KDM wiring:  
 The KDM is powered from a low voltage, energy limited source so it can be mounted outside of a control panel if it is protected from mechanical damage.

**NOTE:** A separate 13 Vdc power supply must be used any time more than two Data ControlBus Modules or KDM are used or are placed more than 100 feet (30.5 meters) from the relay module.

9. Maximum wire lengths:
  - a. 7800 SERIES Relay Module leadwires—The maximum length of leadwire is 300 feet (91.4 meters) to terminal inputs (Control, Preignition Interlock, Running/Lockout Interlock, High Purge Switch and Low Fire Switch).
  - b. Flame Detector leadwires—The maximum flame sensor leadwire length is limited by the flame signal strength.
  - c. Remote Reset leadwires—The maximum length of wire is 1000 feet (305 meters) to a Remote Reset push-button.
  - d. Data ControlBus Module—The maximum Data ControlBus Module™ cable length depends on the number of system modules connected, the noise conditions and the cable used. The maximum length of all Data ControlBus Module™ interconnecting wire is 4000 feet (1219 meters).
10. Make sure loads do not exceed the terminal ratings. Refer to the label on the 7800 SERIES Relay Module or to the ratings in Table 3.

**Table 1. Recommended Wire Sizes and Part Numbers.**

Application	Recommended Wire Size	Recommended Part Numbers
Line Voltage Terminals	14, 16, or 18 AWG copper conductor, 600 volt insulation, moisture-resistant wire.	TTW60C, THW75C, THHN90C.
KDM <sup>a</sup>	22 AWG two-wire twisted pair with ground, or five-wire.	Belden 8723 shielded cable or equivalent.
Data ControlBus Module™		
Remote Reset Module	22 AWG two-wire twisted pair, insulated for low voltage.	—
Communications Interface ControlBus™ Module	22 AWG two-wire twisted pair with ground.	Belden 8723 shielded cable or equivalent.
13 Vdc full wave rectified transformer power input	18 AWG wire insulated for voltages and temperatures for given application.	TTW60C, THW75C, THHN90C.

<sup>a</sup> The KDM, Data ControlBus Module™ (for remote mounting or communications) or Communication Interface ControlBus™ Module must be wired in a daisy chain configuration, (1(a)-1(a), 2(b)-2(b), 3(c)-3(c)). The order of interconnection of all the devices listed above is not important. Be aware that modules on the closest and farthest end of the daisy chain configuration string require a 120 ohm (1/4 watt minimum) resistor termination across terminals 1 and 2 of the electrical connectors for connections over 100 feet (30.5 meters).

**Table 2. Recommended Grounding Practices.**

Ground Type	Recommended Practice
Earth ground (subbase and relay module)	<ol style="list-style-type: none"> <li>1. Use to provide a connection between the subbase and the control panel of the equipment. Earth ground must be capable of conducting enough current to blow the 15A fuse (or breaker) in the event of an internal short circuit.</li> <li>2. Use wide straps or brackets to provide minimum-length, maximum-surface area ground conductors. If a leadwire must be used, use 14 AWG copper wire.</li> <li>3. Make sure that mechanically tightened joints along the ground path are free of nonconductive coatings and protected against corrosion on mating surfaces.</li> </ol>
Signal Ground (KDM, Data ControlBus Module™, Communications Interface ControlBus™ Module)	Use the shield of the signal wire to ground the device to the signal ground terminal 3(c) of each device. Connect the shield at both ends of the daisy chain to earth ground.

**Table 3. EC7810A/EC7820A Terminal Ratings.**

Terminal No.	Abbreviation	Description	Ratings
G	—	Flame Sensor Ground <sup>a</sup>	—
Earth G	—	Earth Ground <sup>a</sup>	—
N	—	Line Voltage Common (Neutral)	—
3 (EC7810A)	L1	Line Voltage Supply (L1)	220/230/240 Vac, 1A, 10A inrush for 5000 cycles.
3 (EC7820A)	AL	Alarm (Normally Open)	220/230/240 vac, 1A, 10 inrush for 5000 cycles.
4 (EC7810A)	AL	Alarm (Normally Open)	220/230/240 Vac, 1A, 10A inrush for 5000 <sup>b</sup> cycles.
4 (EC7820A)	FAN	Burner/Blower Motor	220/230/240 Vac, 4A at P.F. = 0.5, 20A inrush.
5 (EC7810A)	Not Used.		
5 (EC720A)	L1	Line Voltage Supply (L1)	220-240 Vac (+10%/-15%), 50/60 Hz (±10%).
6	RT	Limits and Burner Control	220/230/240 Vac, 5A (maximum).
7 (EC7810A)	Not Used		
7 (EC7820A)	LD2	Airflow Switch Input	220/230/240 Vac, 1 mA.
8	PV1	Pilot Valve 1 (interrupted)	220/230/240 Vac, 4A at PF = 0.5, 20A inrush. <sup>c</sup>
9	MV	Main Fuel Valve <sup>d</sup>	220/230/240 Vac, 4A at PF = 0.5, 20A inrush. <sup>c</sup>
10	IGN	Ignition	220/230/240 Vac, 4A at PF = 0.2. <sup>c</sup>
F(11)	—	Flame Signal	135 to 220 Vac, current limited.
12	Not Used		
13	COM	Firing Rate Common	220/230/240 Vac, 4A at PF = 0.5. <sup>d</sup>
14	MOD	Firing Rate Modulate	220/230/240 Vac, 4A at PF = 0.5. <sup>d</sup>
15	Not Used		
16	—	Control Voltage	220-240 Vac (+10%/-15%).
17	ES2	Preignition Interlock Input	220/230/240 Vac, 1 mA.
18	ES1	Low Fire Switch Input	220/230/240 Vac, 1 mA.
19	Not Used		
20	LOS	Lockout Input	220/230/240 Vac, 1 mA.
21	PV2	Pilot Valve 2 (Intermittent)	220/230/240 Vac, 4A at PF = 0.5, 20A inrush. <sup>c</sup>
22	SHTR	Shutter	220-240 Vac, 0.25A. <sup>e</sup>

<sup>a</sup> See Table 2.

<sup>b</sup> 2000 VA maximum connected load to 7800 SERIES Relay Module Assembly.

<sup>c</sup> Total load current, excluding burner/boiler motor and firing rate outputs, cannot exceed 5A, 25A inrush.

<sup>d</sup> Can also be 24 Vac, 3A at P.F. = 0.5.

<sup>e</sup> 220-240 Vac to 120 Vac, 10 VA minimum step-down transformer (not provided) required to drive shutter.

## Final Wiring Check

1. Check the power supply circuit. The voltage and frequency tolerance must match those of the 7800 SERIES Relay Module. A separate power supply circuit may be required for the 7800 SERIES Relay Module. Add the required disconnect means and overload protection.
2. Check all wiring circuits and complete the Static Checkout before installing the 7800 SERIES Relay Module on the subbase.
3. Install all electrical connectors.
4. Restore power to the panel.

## STATIC CHECKOUT

After checking all wiring, perform this checkout before installing the 7800 SERIES Relay Module on the subbase. These tests verify the Q7800 Wiring Subbase is wired correctly, and the external controllers, limits, interlocks, actuators, valves, transformers, motors and other devices are operating properly. See Tables 4 and 5.

For further checkout and troubleshooting, see form 65-0229.

## WARNING

**Explosion Hazard, Electrical Shock Hazard.  
Can cause serious injury, death or equipment damage.**

1. Close all manual fuel shutoff valve(s) before starting these tests.
2. Use extreme care while testing the system. Line voltage is present on most terminal connections when power is on.
3. Open the master switch before installing or removing a jumper on the subbase.
4. Before continuing to the next test, be sure to remove test jumper(s) used in the previous test.
5. Replace all limits and interlocks that are not operating properly. Do not bypass limits and interlocks.



## CAUTION

**Equipment Damage Hazard.**

**High voltage dielectric test can cause equipment damage.**

Do not perform a dielectric test with the 7800 SERIES Relay Module installed. Internal surge protectors break down and conduct current, causing dielectric test failure and destruction of the internal lightning and high current protection.



## CAUTION

**Equipment Shutdown Hazard.**

**Improper procedure causes lockout.**

Clipping and removing a Site Configurable Jumper after 200 hours of operation results in a hard lockout (Code 110).

## Equipment Recommended

1. Voltmeter (1M ohm/volt minimum sensitivity) set on the 0-300 Vac scale.
2. Two jumper wires; no. 14 wire, insulated, 12 in. (304.8 mm) long with insulated alligator clips at both ends.

## General Instructions

1. Perform all applicable tests listed in Tables 4 and 5, in the order listed.
2. Make sure all manual shutoff valve(s) are closed.
3. For each test, open the master switch and install the jumper wire(s) between the subbase wiring terminals listed in the Test Jumpers section.
4. Close the master switch before observing operation.
5. Read the voltage between the subbase wiring terminals listed in the Voltmeter column.
6. If there is no voltage or the operation is abnormal, check the circuits and external devices as described in the last column.
7. Check all wiring for proper connections, tight terminal screws, and appropriate wire and wiring techniques. Replace all damaged or incorrectly sized wires.
8. Replace faulty controllers, limits, interlocks, actuators, valves, transformers motors and other devices, as required.
9. Make sure normal operation is obtained for each required test before continuing the checkout.
10. After completing each test, be sure to remove the test jumper(s).

**Table 4. EC7810 Static Checkout.**

Test No.	Test Jumpers	Voltmeter	Normal Operation	If Operation is Abnormal, Check the Items Listed Below
1	None	3-L2	Line voltage at terminal 3.	<ol style="list-style-type: none"> <li>1. Master Switch.</li> <li>2. Power connected to the master switch.</li> <li>3. Overload protection (fuse, circuit breaker) has not opened the power line.</li> </ol>
2	None	18-L2	Line voltage at terminal 18.	Low Fire Start Switch.
3	None	17-L2	Line voltage at terminal 17.	Preignition interlocks.
4	3-16	—	Alarm (if used and connected to terminal 16) turns on.	Alarm.

**Table 4. EC7810 Static Checkout. (Continued)**

Test No.	Test Jumpers	Voltmeter	Normal Operation	If Operation is Abnormal, Check the Items Listed Below
Disconnect alarm or turn off for following tests.				
5	3-16	L2-20	Line voltage at terminal 20.	Lockout switches.
6	3-16	L2-6	Line voltage at terminal 6.	<ol style="list-style-type: none"> <li>Limits.</li> <li>Burner controller.</li> </ol>
Connect alarm or turn on for remainder of tests.				
7	3-10	—	Ignition spark (if ignition transformer is connected to terminal 10).	<ol style="list-style-type: none"> <li>Watch for spark or listen for buzz.</li> <li>Ignition electrodes are clean</li> <li>Ignition transformer is okay.</li> </ol>
8	3-8	—	<ol style="list-style-type: none"> <li>Ignition spark (if ignition transformer is connected to terminal 8).</li> <li>Automatic pilot valve opens (if connected to terminal 8).</li> </ol> <p>NOTE: Refer to wiring diagram of system being tested.</p>	<ol style="list-style-type: none"> <li>Watch for spark or listen for buzz.                             <ol style="list-style-type: none"> <li>Ignition electrodes are clean.</li> <li>Ignition transformer is okay.</li> </ol> </li> <li>Listen for click or feel head of valve for activation.                             <ol style="list-style-type: none"> <li>Actuator, if used.</li> <li>Pilot valve.</li> </ol> </li> </ol>
9	3-21	—	Same as test no. 8 for connections to terminal 8. If using direct spark ignition on a model with intermittent pilot on terminal 21, check the optional second stage fuel valve, if used.	Same as test no. 8. If using direct spark ignition, check the first stage fuel valve(s) instead of the pilot valve.
10	3-9	—	Automatic main fuel valve(s) open(s). If using direct spark ignition on a model with intermittent pilot on terminal 21, check the optional second stage fuel valve, if used.	<ol style="list-style-type: none"> <li>Listen for and observe operation of the main fuel valve(s) and actuator(s).</li> <li>Valve(s) and actuator(s).</li> </ol>
11	4-3	—	Alarm (if used) turns on.	Alarm.
12	15-13	18-L2	<ol style="list-style-type: none"> <li>Raise setpoint of series 90 controller. Firing rate motor should drive toward open.</li> <li>Lower setpoint of series 90 controller. Firing rate motor should drive toward closed.</li> </ol> <p>NOTE: If damper motor is used, motor drives open; zero volts at terminal 18 after motor starts driving open.</p>	<ol style="list-style-type: none"> <li>Series 90 controller.</li> <li>Firing rate motor and transformer.</li> <li>Low Fire Switch.</li> </ol>
Final	 <p><b>CAUTION</b>  <b>Electrical Shock Hazard or Equipment Damage Hazard.</b>  <b>Can cause injury or equipment/control damage.</b>                      After completing these tests, open the master switch and remove all test jumpers from the subbase terminals. Also remove bypass jumpers from the low fuel pressure limits (if used).</p>			

**Table 5. EC7820 Static Checkout.**

Test No.	Test Jumpers	Voltmeter	Normal Operation	If Operation is Abnormal, Check the Items Listed Below
1	None	5-L2	Line voltage at terminal 5.	<ol style="list-style-type: none"> <li>Master Switch.</li> <li>Power connected to master switch.</li> <li>Overload protection (fuse, circuit breaker) has not opened the power line.</li> </ol>
2	None	18-L2	Line voltage at terminal 18.	Low Fire Start Switch.
3	None	17-L2	Line voltage at terminal 17.	Preignition interlocks.
4	5-16	—	Alarm (if used and connected to terminal 16) turns on.	Alarm.
Disconnect alarm or shut off for following tests.				
5	5-16	20-L2	Line voltage at terminal 20.	Lockout limits.
6	5-16	6-L2	Line voltage at terminal 6.	<ol style="list-style-type: none"> <li>Limits.</li> <li>Burner Controller.</li> </ol>

Table 5. EC7820 Static Checkout. (Continued)

Test No.	Test Jumpers	Voltmeter	Normal Operation	If Operation is Abnormal, Check the Items Listed Below
7	5-16 5-4	7-L2	<ol style="list-style-type: none"> <li>0 volts at terminal 7.</li> <li>Fan starts.</li> <li>Line voltage at terminal 7.</li> </ol>	<ol style="list-style-type: none"> <li>Fan motor circuit. <ol style="list-style-type: none"> <li>Manual switch of fan.</li> <li>Fan motor power supply, overload protection and starter.</li> <li>Fan motor.</li> </ol> </li> <li>Airflow switch.</li> </ol>
8	5-10	—	Ignition spark (if ignition transformer is connected to terminal 10).	<ol style="list-style-type: none"> <li>Watch for spark or listen for buzz.</li> <li>Ignition electrodes are clean.</li> <li>Ignition transformer is okay.</li> </ol>
9	5-8	—	<ol style="list-style-type: none"> <li>Ignition spark (if ignition transformer is connected to terminal 8).</li> <li>Automatic pilot valve opens (if connected to terminal 8).</li> </ol> <p>NOTE: Refer to wiring diagram of system being tested.</p>	<ol style="list-style-type: none"> <li>Watch for spark or listen for buzz. <ol style="list-style-type: none"> <li>Ignition electrodes are clean.</li> <li>Ignition transformer is okay.</li> </ol> </li> <li>Listen for click or feel head of valve for activation. <ol style="list-style-type: none"> <li>Actuator, if used.</li> <li>Pilot valve.</li> </ol> </li> </ol>
10	5-21	—	Same as test no. 9 for connections to terminal 8. If using direct spark ignition, check the first stage fuel valve(s) instead of the pilot valve.	Same as test no. 9. If using direct spark ignition, check the first stage fuel valve(s) instead of the pilot valve.
11	5-9	—	Automatic main fuel valve(s) opens. If using direct spark ignition on a model with intermittent pilot on terminal 21, check the optional second stage fuel valve, if used.	<ol style="list-style-type: none"> <li>Listen for and observe operation of the main fuel valve(s) and actuator(s).</li> <li>Valve(s) and actuator(s).</li> </ol>
12	4-5	—	Alarm (if used) turns on.	Alarm.
13	15-13	18-L2	<ol style="list-style-type: none"> <li>Raise setpoint of series 90 controller. Firing rate motor should drive toward open.</li> <li>Lower setpoint of series 90 controller. Firing rate motor should drive toward closed.</li> </ol> <p>NOTE: If damper motor is used, motor drives open; zero volts at terminal 18 after motor starts driving open.</p>	<ol style="list-style-type: none"> <li>Series 90 Controller.</li> <li>Firing rate motor and transformer.</li> <li>Low Fire Start Switch.</li> </ol>
Final	 <p><b>CAUTION</b>  <b>Electrical Shock Hazard or Equipment Damage Hazard.</b>  <b>Can cause injury or equipment/control damage.</b>  After completing these tests, open the master switch and remove all test jumpers from the subbase terminals. Also remove bypass jumpers from the low fuel pressure limits (if used).</p>			

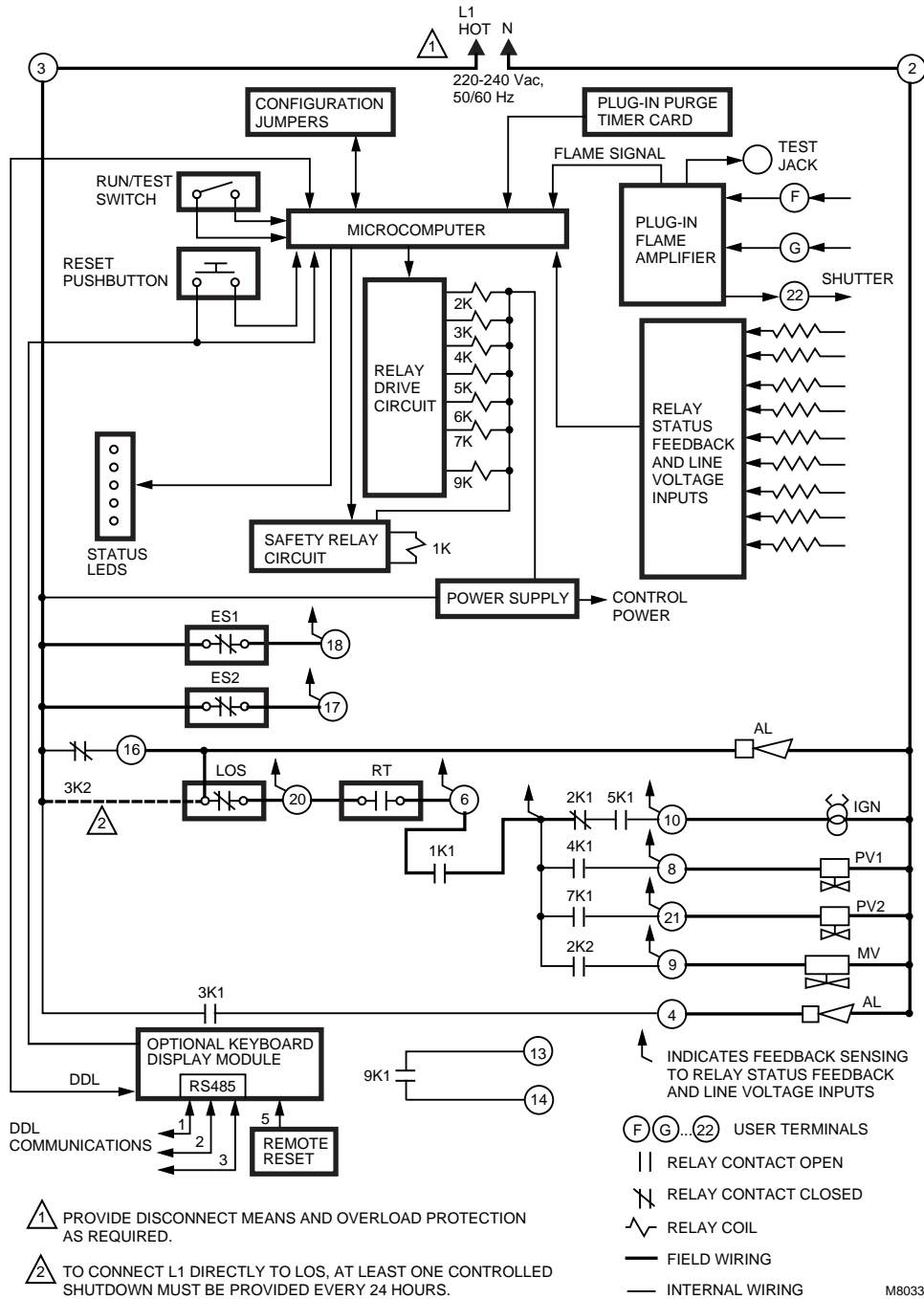

Fig. 1. Internal block diagram of EC7810A Relay Module (see Fig. 3 for detailed wiring instructions).



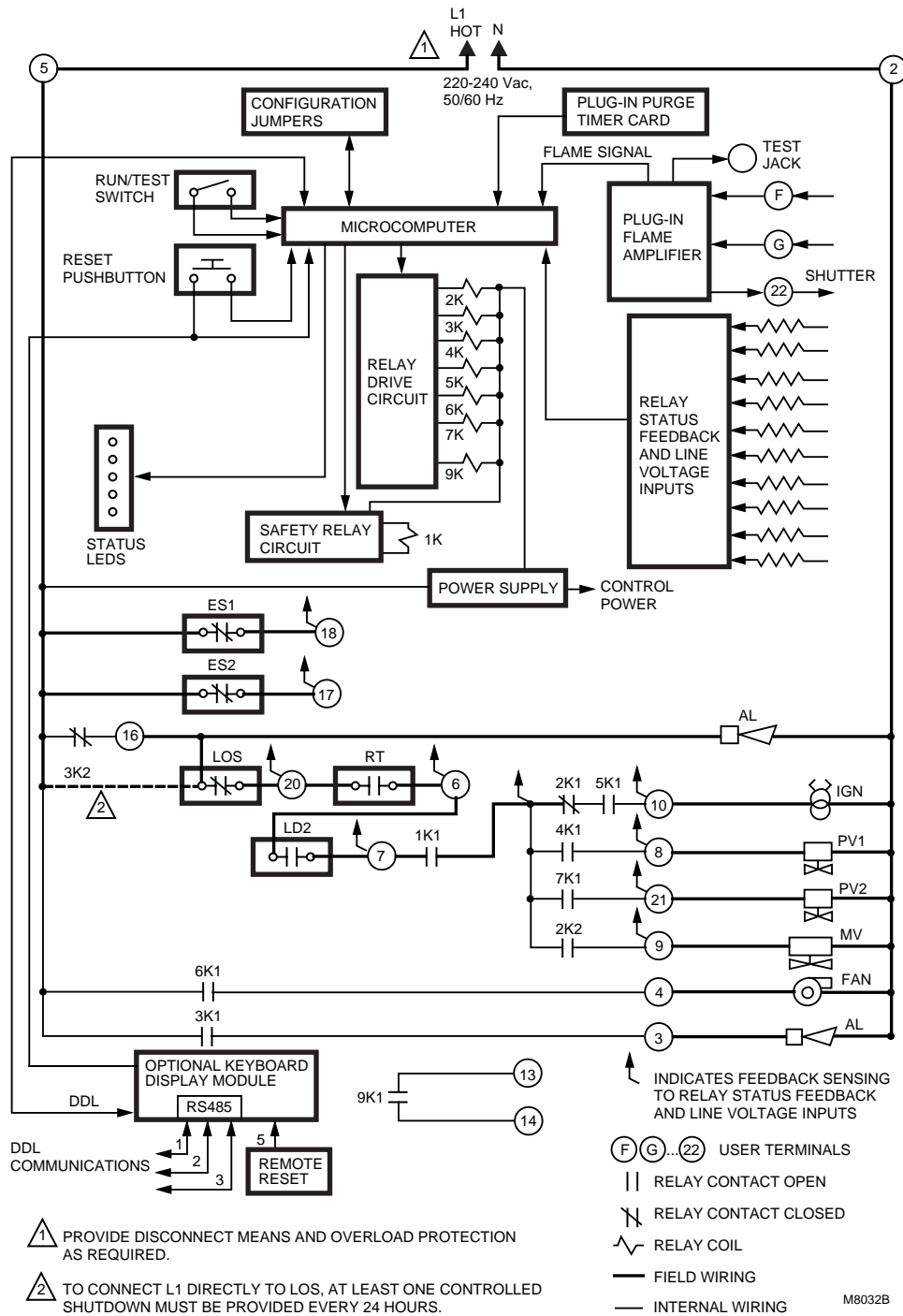
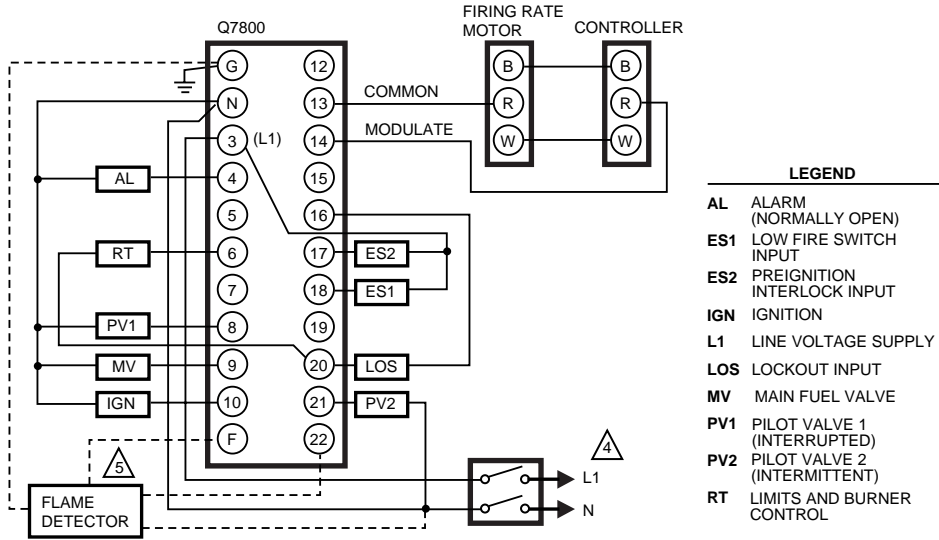
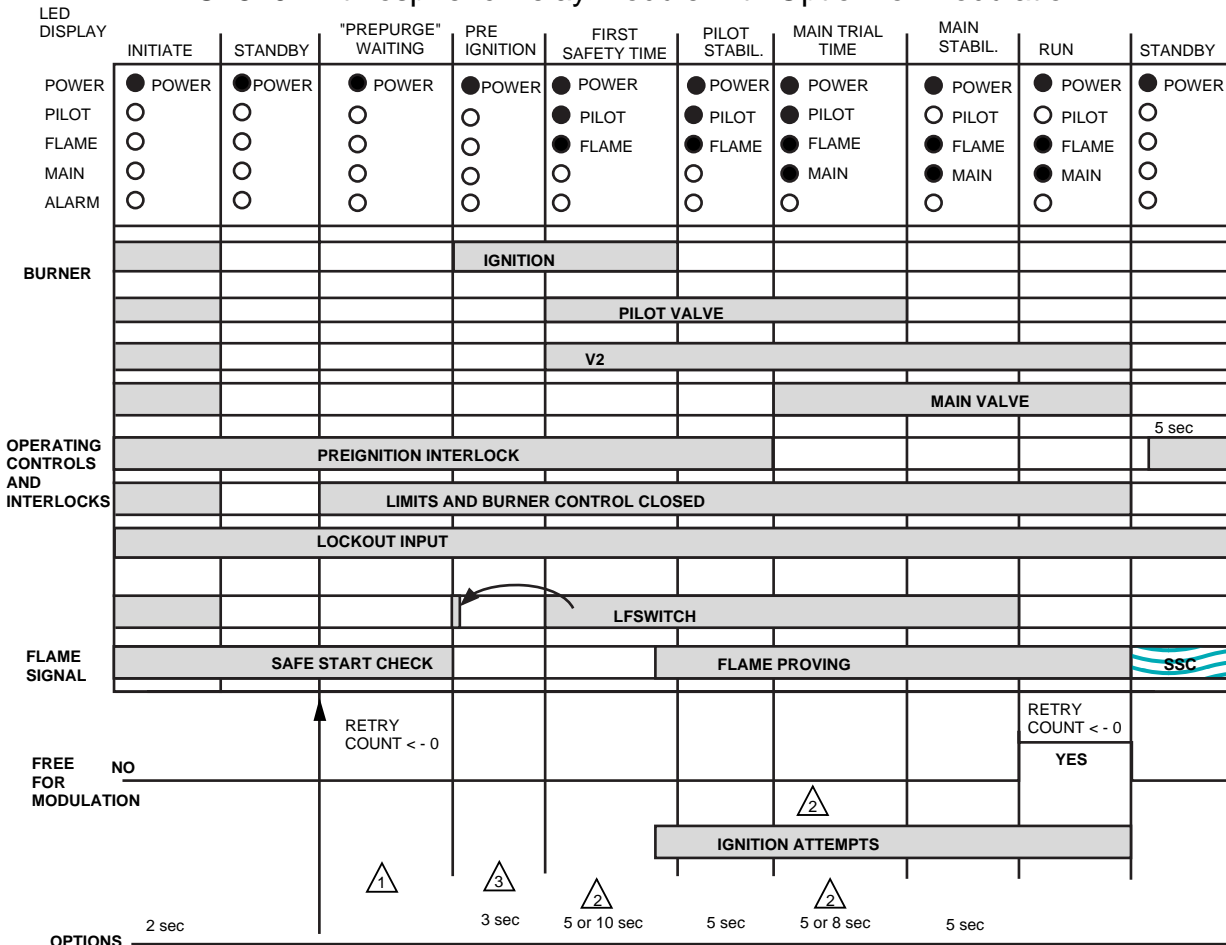

Fig. 2. Internal block diagram of EC7820A Relay Module (see Fig. 4 for detailed wiring instructions).



EC7810A Atmospheric Relay Module with Option for Modulation



NOTE: IGNITION ATTEMPTS: 1 OR 5 FOR 5: IF NO FLAME, RECYCLE TO WAITING PERIOD; LOCK OUT AFTER 5 TRIES.

- 1 SELECT VIA ST7800A PURGE TIMER CARD
- 2 SELEC VIA CONFIGURATION JUMPERS OR MODEL NUMBERS.
- 3 DUE TO 1 EXTRA SECOND FOR SAFETY RELAY TEST, TIMING WILL VARY FROM 3 TO 4 SECONDS.

4 220/230/240 VAC, 50/60 Hz POWER SUPPLY.

5 WHEN USING A C7061A; C7076A,D; SENSOR, A 220/240 VAC TO 120 VAC, 10 VA STEP-DOWN TRANSFORMER MUST BE INSTALLED TO DRIVE THE SHUTTER. WHEN USING FLAME DETECTOR SPECIFICATIONS FOR WIRING DETAILS.

M11629

Fig. 3. Wiring subbase and operation sequence for EC7810A Relay Module.

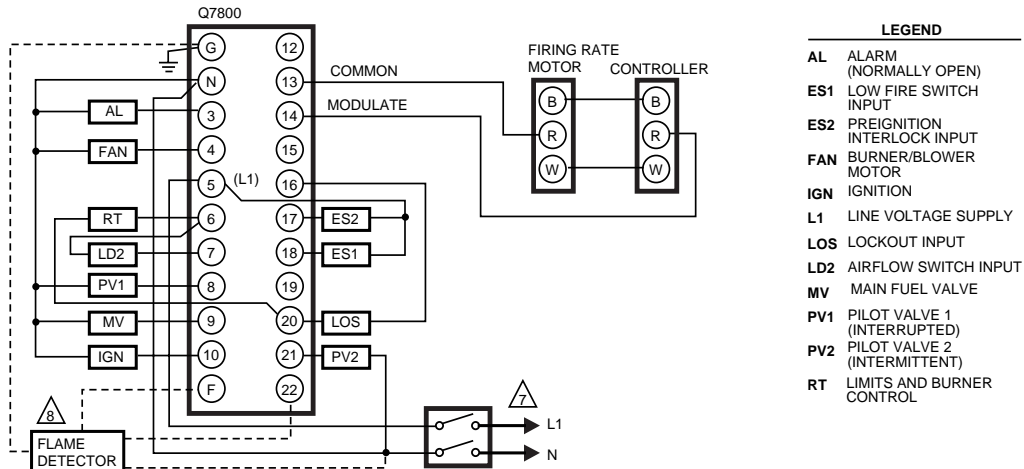

EC7820A Atmospheric + Fan Relay Module with Option for Modulation

LED DISPLAY	INITIATE	STANDBY	"PREPURGE" WAITING	PRE IGNITION	FIRST SAFETY TIME	PILOT STABIL.	MAIN TRIAL TIME	MAIN STABIL.	RUN	STANDBY
POWER	● POWER	● POWER	● POWER	● POWER	● POWER	● POWER	● POWER	● POWER	● POWER	● POWER
PILOT	○	○	○	○	● PILOT	● PILOT	● PILOT	○ PILOT	○ PILOT	○
FLAME	○	○	○	○	● FLAME	● FLAME	● FLAME	● FLAME	● FLAME	○
MAIN	○	○	○	○	○	○	● MAIN	● MAIN	● MAIN	○
ALARM	○	○	○	○	○	○	○	○	○	○
BURNER	BURNER/BLOWER MOTOR									
	IGNITION									
	PILOT VALVE									
	V2									
	MAIN VALVE									
OPERATING CONTROLS AND INTERLOCKS	PREIGNITION INTERLOCK									
	LIMITS AND BURNER CONTROL CLOSED									
	LOCKOUT INPUT									
	AFS CHK									
	AIRFLOW SWITCH CLOSED									
FLAME SIGNAL	SAFE START CHECK									
	FLAME PROVING									
	SSC									
FREE FOR MODULATION	RETRY COUNT < - 0									
	RETRY COUNT < - 0									
OPTIONS	2 sec AFS CHK									
	IGNITION ATTEMPTS									

NOTE: IGNITION ATTEMPTS: 1 OR 5 FOR 5: IF NO FLAME, RECYCLE TO WAITING PERIOD; LOCK OUT AFTER 5 TRIES.

- 1. IF ON AT CALL FOR HEAT, HOLD (120 sec). LOCK OUT IF STILL ON.
- 2. IF OFF AFTER 10 SEC OF FAN, LOCK OUT.
- 3. TAKE LOCKOUT ACTION, CONTINUE 15 SEC POSTPURGE TIMING
- 4. SELECT VIA ST7800A PURGE TIMER CARD
- 5. SELECT VIA CONFIGURATION JUMPERS OR MODEL NUMBERS
- 6. DUE TO 1 EXTRA SECOND FOR SAFETY RELAY TEST, TIMING WILL VARY FROM 3 TO 4 SECONDS.
- 7. 220/230/240 VAC, 50/60 Hz POWER SUPPLY.
- 8. WHEN USING A C7061A OR C7076A,D SENSOR, A 220/240 VAC TO 120 VAC, 10 VA STEP-DOWN TRANSFORMER MUST BE INSTALLED TO DRIVE THE SHUTTER. REFER TO AMPLIFIER AND FLAME DETECTOR SPECIFICATIONS FOR WIRING DETAILS.

M11630A

Fig. 4. Wiring subbase and operation sequence for EC7820A Relay Module.

## Mounting Relay Module

1. Mount the 7800 SERIES RELay Module vertically on the Q7800 Subbase, or mount horizontally with the knife blade terminals pointing down. When mounted on the Q7800A, the 7800 SERIES Relay Module must be in an electrical enclosure.
2. When mounting in an electrical enclosure, provide adequate clearance for service, installation and removal of the 7800 SERIES Relay Module, KDM, flame amplifier, flame amplifier signal voltage probes, electrical signal voltage probes, and electrical connections.
  - a. Allow an additional two inches below the 7800 SERIES Relay Module for the flame amplifier mounting.
  - b. Allow an optional three-inch minimum on both sides of the 7800 SERIES Relay Module for electrical signal voltage probes.

3. Make sure no subbase wiring is projecting beyond the terminal blocks. Tuck wiring in against the back of the subbase so it does not interfere with the knife blade terminals or bifurcated contacts.

### IMPORTANT

*Install the 7800 SERIES Relay Module with a plug-in motion rather than a hinge action.*

4. Mount the 7800 SERIES Relay Module by aligning the four L-shaped corner guides and knife blade terminals with the bifurcated contacts on the wiring subbase and tightening the two screws securely without deforming the plastic.
5. Mount other required and optional system components by referring to Fig. 5 and the instructions provided with each component.

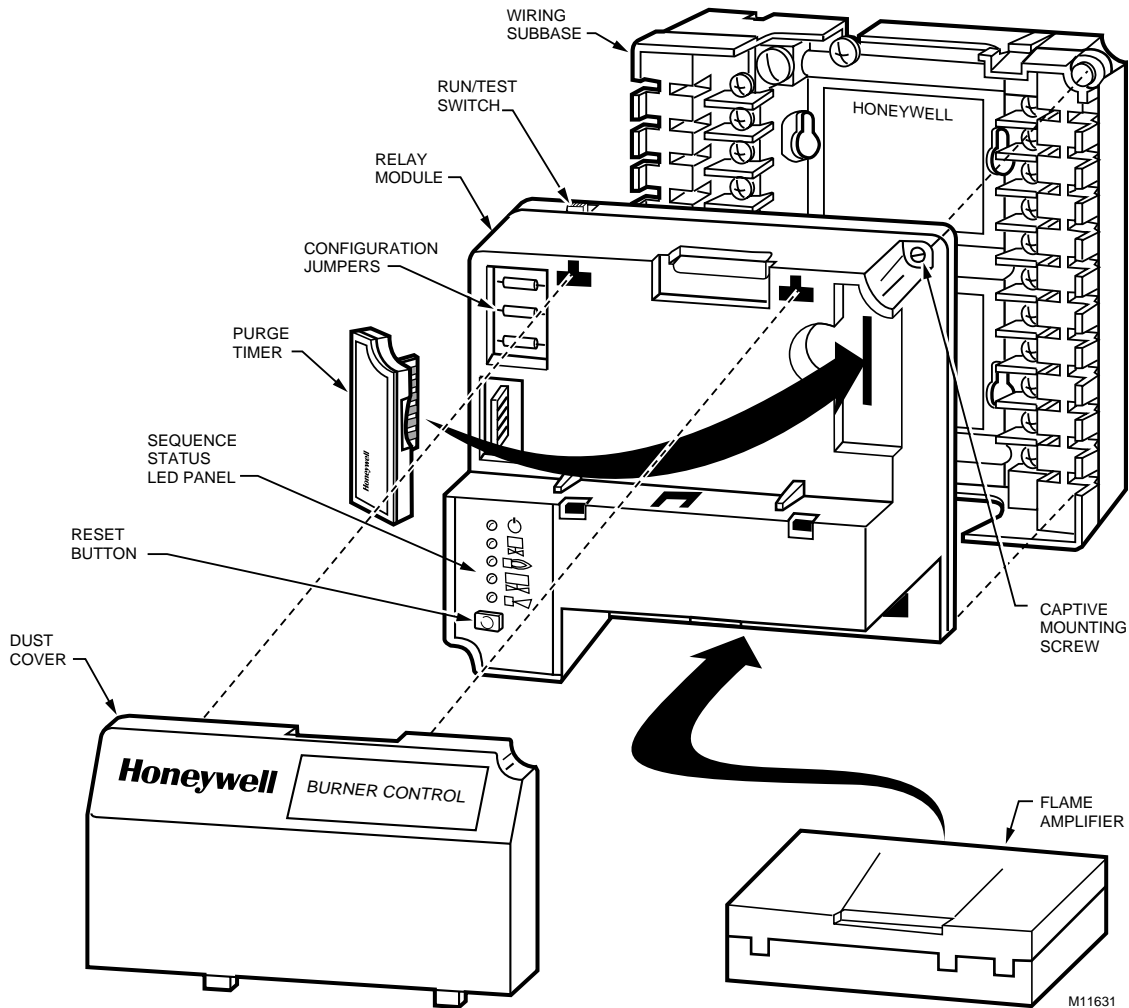

Fig. 5. 7800 SERIES Relay Module exploded view.

## PRINCIPAL TECHNICAL FEATURES

The EC7810A or EC7820A Relay Module provides all customary flame safeguard functions while providing

significant advancements in the areas of safety, annunciation, and system diagnostics.

## Safety Shutdown (Lockout) Occurs If:

### INITIATE Period:

1. Purge card is not installed or is removed.
2. Purge card is defective.
3. Configuration jumpers were changed (after 200 hours of operation).
4. Ac line power errors—see Operation.
5. Four-minute INITIATE period is exceeded.

### STANDBY Period:

1. Flame signal is present after 40 seconds. Preignition Interlock is open an accumulative time of 30 seconds.
2. Airflow Switch feature is enabled and the Airflow Switch is closed for 120 seconds with Limits and Burner Control closed (EC7820A).
3. Ignition/pilot valve/intermittent pilot valve terminal is energized.
4. Main valve terminal is energized.
5. Internal system fault.
6. Purge card is not installed or is removed.
7. Purge card is defective.
8. Lockout Input opens during STANDBY.

### PURGE Period:

1. Preignition Interlock opens anytime during PURGE.  
Flame signal detected during PURGE.

2. Airflow Switch Input does not close within 10 seconds (EC7820A).
3. If Airflow Switch is disabled, there is no jumper between terminals 6 and 7 (EC7820a).
4. Airflow Switch opens during PURGE (EC7820a).
5. Lockout Input opens during PURGE.
6. Ignition/pilot valve/intermittent pilot valve terminal is energized.
7. Main valve terminal is energized.
8. Internal system fault.
9. Purge card is removed.
10. Purge card is defective.

### PREIGNITION Period:

1. Lockout Input opens during PREIGNITION.
2. Airflow Switch opens during PREIGNITION (EC7820A).
3. Preignition Interlock opens during PREIGNITION.
4. Ignition terminal is not energized.
5. Pilot valve/intermittent pilot valve terminal is energized.
6. Main valve terminal is energized.
7. Internal system fault.
8. Purge card is removed.
9. Purge card is defective.

### SAFETY 1 Period:

1. Lockout Input opens during SAFETY 1.
2. Airflow Switch opens during SAFETY 1 (EC7820A).
3. Low Fire Switch opens.
4. No flame is present at the end of SAFETY 1.

NOTE: Some devices allow five ignition attempts.

5. Ignition terminal is not energized.
6. Pilot valve/intermittent pilot valve terminal is not energized.
7. Main valve terminal is energized.
8. Internal system fault.
9. Purge card is removed.
10. Purge card is defective.
11. Preignition Interlock opens during SAFETY 1.

### PILOT STAB. Period:

1. Lockout Input opens during PILOT STAB.
2. Airflow Switch opens during PILOT STAB. (EC7820A).
3. Low Fire Switch opens.
4. No flame is present.

NOTE: Some devices allow five ignition attempts.

5. Ignition terminal is energized.
6. Pilot valve/intermittent pilot valve terminal is not energized.
7. Main valve terminal is energized.
8. Internal system fault.
9. Purge card is removed.
10. Purge card is defective.
11. Preignition Interlock opens during PILOT STAB.

### MAIN TRIAL Period:

1. Lockout Input opens during MAIN TRIAL.
2. Airflow Switch opens during MAIN TRIAL (EC7820A).
3. Low Fire Switch opens.
4. No flame is present.

NOTE: Some devices allow five ignition attempts.

5. Ignition terminal is energized.
6. Pilot valve/intermittent pilot valve terminal is not energized.
7. Pilot valve is energized during MAIN TRIAL stabilization.
8. Main valve terminal is not energized.
9. Internal system fault.
10. Purge card is removed.
11. Purge card is defective.

### RUN Period:

1. No flame is present.

NOTE: Some devices allow five ignition attempts.

2. Lockout Input opens.
3. Ignition/interrupted pilot valve terminal is energized.
4. Main valve terminal is not energized.
5. Internal system fault.
6. Purge card is removed.
7. Purge card is defective.
8. Airflow Switch opens (EC7820A).

## OPERATION

### Sequence of Operation

The 7800 SERIES Relay Module has the operating sequences listed below. See Fig. 5 and 6.

#### Initiate

The 7800 SERIES Relay Module enters the INITIATE sequence when the Relay Module is powered. The 7800 SERIES Relay Module can also enter the INITIATE sequence if the Relay Module verifies voltage fluctuations of +10/-15 percent or frequency fluctuations of  $\pm 10$  percent during any part of the operating sequence. The INITIATE sequence lasts for two seconds unless the voltage or frequency tolerances are not met. When the tolerances are not met, a hold condition is initiated and displayed on the KDM for at least five seconds. When the tolerances are met, the INITIATE sequence restarts. If the condition is not corrected and the hold condition exists for four minutes, the 7800 SERIES Relay Module locks out. Causes for hold conditions in the INITIATE sequence:

- a. ac line dropout detection.
- b. ac line noise prevents a sufficient reading of the line voltage inputs.
- c. Low line voltage brownouts.
- d. L1 and N are incorrectly wired, causing incorrect ac line phase.

#### Standby

The 7800 SERIES Relay Module is ready to start an operating sequence when the operating control determines a call for heat is present. The burner switch, limits, operating control and all microcomputer-monitored circuits must be in the correct state for the relay module to continue into the PURGE sequence.

#### Normal Start-Up Purge

The 7800 SERIES Relay Module provides PURGE timing selectable from two seconds to thirty minutes with power applied and the operating control indicating a call for heat.

- a. Preignition Interlocks, Limits and Burner Control, Run/Test Switch, Airflow Switch input (EC7820A), Lockout Input and all microcomputer-monitored circuits must be in the correct operating state.
- b. Blower motor output (EC7820A, terminal 4) is powered to start the PURGE sequence. PURGE timing does not begin until the Airflow Switch Input (EC7820A, terminal 7) is closed.
- c. Preignition Interlock input must remain closed throughout PURGE; otherwise, a safety shutdown occurs.
- d. For the EC7820A, the Airflow Switch input must close by ten seconds into PURGE; otherwise, a safety shutdown occurs.

#### Ignition Trials

1. Preignition:
  - a. The ignition transformer, terminal 10, are energized for three seconds.
2. First Safety Time (SAFETY1):

- a. With the Low Fire Switch input closed:
  - (1) The pilot valves and ignition transformer, terminals 8, 10, and 21, are energized. Terminal 8 is an interrupted pilot valve, while terminal 21 is an intermittent pilot valve.
  - (2) During SAFETY1, the Low Fire Switch Input must be closed. If it opens, a safety shutdown occurs.
  - (3) The Preignition Interlock Input is ignored during MAIN TRIAL and RUN.
- b. Flame must be proven by the end of five or ten seconds to allow the sequence to continue. A safety shutdown occurs if there is no flame. Some devices allow five ignition attempts. The number of attempts is indicated on the first line of the display during SAFETY1.
3. Pilot stabilization (PILOT STAB.). With flame proven, the ignition, terminal 10, is de-energized. The duration of this state is 5 seconds.
4. Main Trial (MAIN TRIAL):
  - a. The MAIN TRIAL time is selectable as five or eight seconds. After PILOT STAB., and with the presence of a flame, the main fuel valve, terminal 9, is powered. If a flame out occurs, the relay module will lock out within one or two seconds, depending on the Flame Failure Response Time (FFRT) of the amplifier. Thus, second safety time is defined as MAIN TRIAL time plus FFRT of the amplifier. Note that some devices allow five ignition attempts
  - b. During MAIN TRIAL, the Low Fire Switch input must be closed. If it opens, a safety shutdown occurs.
  - c. After five or eight seconds of MAIN TRIAL, terminal 8 is de-energized for main stabilization. Flame must remain proven during this period.

#### Run

1. The firing rate motor releases to modulation.
2. The relay module is now in RUN and remains in RUN until the controller input, terminal 6, opens, indicating that the demand is satisfied or a limit has opened.

NOTE: 7800 SERIES Relay Module LEDs. POWER, PILOT, FLAME, MAIN and ALARM provide positive visual indication of the program sequence. See Fig. 5.

#### Run/Test Switch

The Run/Test Switch is located on the top side of the 7800 SERIES Relay Module, see Fig. 6. The Run/Test Switch allows the burner sequence to be altered as follows:

1. In the measured PURGE sequence, the Run/Test Switch, when placed in the TEST position, causes the PURGE timing to stop.
2. During the PILOT STAB. period, the Run/Test Switch, when placed in the TEST position, stops the timer, allowing for pilot turn-down test and other burner adjustments. This activates a fifteen-second flameout timer that permits pilot flame adjustment without nuisance safety shutdowns.
3. During Run, the Run/Test Switch, when placed in the TEST position, drives the firing rate motor to the OPEN position.

**NOTE:** When the 7800 SERIES Relay Module is switched to the TEST mode, it stops and holds at the next Run/Test Switch point in the operating sequence. Make sure that the Run/Test Switch is in the RUN position before leaving the installation.

## SETTINGS AND ADJUSTMENTS

### Selectable Site-Configurable Jumpers

The EC7810A Relay Module has two site-configurable jumper options while the EC7820A Relay Module has three jumper options, see Fig. 6 and Table 6. If necessary, clip the site-configurable jumper with side cutters and remove the resistors from the relay module. The relay module reads the settings of these configuration jumpers at startup. After 200 hours of main valve operation, the relay module locks the jumper settings into internal memory. If these jumpers are changed after the lockin occurs, the relay module will lock out. This safety function assures that the relay module cannot be modified after it is installed in a particular location.

If JR3 (Airflow Switch) is intact (no Airflow Switch), then a jumper must be installed between terminals 6 and 7 of the wiring subbase. If jumper JR3 is clipped (Airflow Switch is present), the relay module locks out if it detects a jumper between terminals 6 and 7.

**SERVICE NOTE:** Clipping and removing a site-configurable jumper enhances the level of safety.

### CAUTION

**Equipment Shutdown Hazard.**  
**Improper procedure causes lockout.**  
 Clipping and removing a Site Configurable Jumper after 200 hours of operation results in a hard lockout (Code 110).

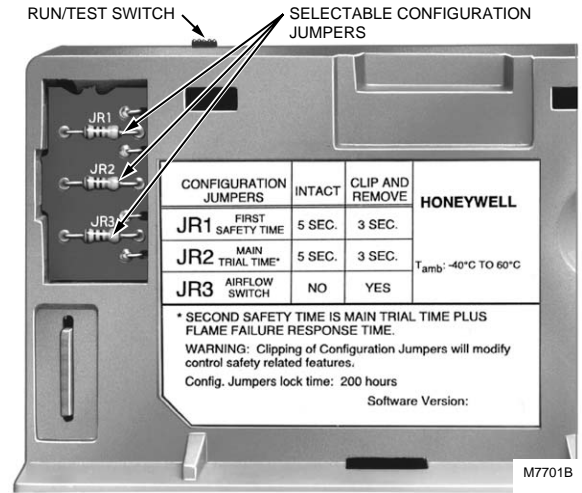

**Fig. 6. Selectable site-configurable jumpers.**

**Table 6. Site configurable jumper options.**

Jumper Number	Description	Intact	Clipped
JR1	First Safety Time	10 seconds	5 seconds
JR2	Main Trial Time	8 seconds	5 seconds
JR3 <sup>a</sup>	Airflow Switch	No	Yes

<sup>a</sup> Omitted on EC7810.

### WARNING

**Explosion Hazard.**  
**Can cause serious injury or death.**  
 Be sure all manual fuel shutoff valves are closed.

**Honeywell**

---

**Automation and Control Solutions**

Honeywell International Inc.  
1985 Douglas Drive North  
Golden Valley, MN 55422

Honeywell Limited-Honeywell Limitée  
35 Dynamic Drive  
Scarborough, Ontario  
M1V 4Z9

