

RM7897A1002, RM7897C1000

7800 SERIES

Relay Modules

INSTALLATION INSTRUCTIONS

APPLICATION

The RM7897A,C are microprocessor-based integrated burner controls for automatically fired gas, oil, or combination fuel single burner applications. The RM7897A,C system consist of a relay module, subbase, amplifier, and purge card. Options include keyboard display module (KDM), Personal Computer Interface, Data ControlBus™ Module, remote display mounting, Expanded Annunciator and Combustion System Manager® Software.

Functions provided by the RM7897A,C include automatic burner sequencing, flame supervision, system status indication, system or self-diagnostics and troubleshooting.

The RM7897 adds a proof of closure input to the standard primary control function of the RM7895/RM7896 product. It adds a blinking fault code function to the POWER LED on Alarm shutdown. It also adds programmable postpurge using the S7800A1142 Keyboard Display Module (KDM). The RM7897A1002 offers selectable pilot operation, intermittent on terminal 8 or interrupted on terminal 21.

The RM7897C1000 offers interrupted pilot and delayed main valve for 2-step firing (Low-High-Low) applications.

This document provides installation and static checkout instructions. Other applicable publications are:

| Publication No. | Product |
|-----------------|--------------------------------------------------|
| 63-2278 | Q7700 Network Interface Unit Product Data |
| 65-0084 | Q7800A,B 22-Terminal Wiring Subbase Product Data |
| 65-0288 | S7800A1142 Keyboard Display Module Product Data |
| 65-0091 | S7810A Data ControlBus Module™ Product Data |
| 65-0095 | S7820 Remote Reset Module Product Data |
| 65-0097 | 221729C Dust Cover Installation Instructions |
| 65-0101 | S7830 Expanded Annunciator Product Data |

| Publication No. | Product |
|-----------------|---------------------------------------------------------------------------------------------------|
| 65-0102 | ZM7850A Combustion System Manager™ Operating Instructions |
| 65-0109 | R7824, R7847, R7848, R7849, R7851, R7861, R7886 Flame Amplifiers for the 7800 Series Product Data |
| 65-0131 | 221818A Extension Cable Assembly Product Data |
| 65-0229 | 7800 SERIES Relay Modules Checkout and Troubleshooting Product Data. |
| 65-0092 | QS7800A ControlBus™ Module, Standard |
| 65-0227 | QS7800B ControlBus™ Module, Multidrop |

SPECIFICATIONS

Electrical Ratings (See Table 3):

Voltage and Frequency:

RM7897A,C: 120 Vac (+10/-15%), 50/60 Hz (± 10%).

Power Dissipation: 10W maximum.

Maximum Total Connected Load: 2000 VA.

Fusing Total Connected Load: 15A Fast Blow, type SC or equivalent.

Environmental Ratings:

Ambient Temperature:

Operating: -40°F to 140°F (-40°C to +60°C).

Storage: -40°F to 150°F (-40°C to +66°C).

Humidity: 85% relative humidity continuous, noncondensing.

Vibration: 0.5G environment.

Approvals:

Underwriters Laboratories Inc. Listed: File No. MP268, Guide No. MCCZ.

Canadian Standards Association Certified: Pending.

Factory Mutual Approved: Report No. Pending.

IRI Acceptable.

Federal Communications Commission: Part 15, Class B, Emissions.



INSTALLATION

When Installing this Product...

1. Read these instructions carefully. Failure to follow them could damage the product or cause a hazardous condition.
2. Check the ratings given in the instructions and marked on the product to make sure the product is suitable for the application.
3. Installer must be a trained, experienced, flame safeguard service technician.
4. After installation is complete, check out the product operation as provided in these instructions.

WARNING

Fire or Explosion Hazard.

Can cause severe injury, death or property damage.

Follow applicable safety requirements when installing a control on a burner to prevent death or severe injury.

WARNING

Electrical Shock Hazard.

Can cause serious injury, death or equipment damage.

Disconnect power supply before beginning installation. More than one disconnect may be required.

IMPORTANT

1. *Wiring connections for the relay modules are unique; refer to Fig. 2 and 3 or the appropriate Specifications for proper subbase wiring.*
2. *Wiring must comply with all applicable codes, ordinances and regulations.*
3. *Wiring must comply with NEC Class 1 (Line Voltage) wiring.*
4. *Loads connected to the RM7897A,C must not exceed those listed on the RM7897A,C label or the Specifications; see Table 1.*
5. *Limits and interlocks must be rated to simultaneously carry and break current to the ignition transformer, pilot valve, and main fuel valve(s).*
6. *All external timers must be listed or component-recognized by authorities who have proper jurisdiction.*
7. *For on-off gas-fired systems, some authorities who have jurisdiction prohibit the wiring of any limit or operating contacts in series between the flame safeguard control and the main fuel valve(s).*
8. *Two flame detectors can be connected in parallel with the exception of Flame Detectors C7015, C7927,C7961 and C7952.*

9. *This equipment generates, uses and can radiate radio frequency energy and, if not installed and used in accordance with the instructions, can cause interference with radio communications. It has been tested and found to comply with the limits for a Class B computing device of Part 15 of FCC rules, which are designed to provide reasonable protection against such interference when operated in a commercial environment. Operation of this equipment in a residential area may cause interference, in which case, the users, at their own expense, may be required to take whatever measures are required to correct this interference.*
10. *This digital apparatus does not exceed the Class B limits for radio noise for digital apparatus set out in the Radio Interference Regulations of the Canadian Department of Communications.*

Location

Humidity

Install the relay module where the relative humidity never reaches the saturation point. The relay module is designed to operate in a maximum 85% relative humidity continuous, noncondensing, moisture environment. Condensing moisture can cause a safety shutdown.

Vibration

Do not install the relay module where it can be subjected to vibration in excess of 0.5G continuous maximum vibration.

Weather

The relay module is not designed to be weather tight. When installed outdoors, protect the relay module in an approved weather-tight enclosure.

Mounting Wiring Subbase

1. Mount the subbase in any position except horizontally with the bifurcated contacts pointing down. The standard vertical position is recommended. Any other position decreases the maximum ambient temperature rating.
2. Select a location on a wall, burner or electrical panel. The Q7800 can be mounted directly in the control cabinet. Be sure to allow adequate clearance for service, installation, access or removal of the RM7897A,C expanded annunciator, keyboard display module, flame amplifier, flame amplifier signal voltage probes, run/test switch, electrical signal voltage probes and electrical field connections.
3. For surface mounting, use the back of the subbase as a template to mark the four screw locations. Then drill the pilot holes.
4. Securely mount the subbase using four no. 6 screws (not provided).

Wiring Subbase

⚠ WARNING

Electrical Shock Hazard.
Can cause severe injury, death or equipment damage.

Disconnect the power supply before beginning installation. More than one disconnect may be required.

The internal block diagram of the RM7897A,C is shown in Fig. 1.

1. For proper subbase wiring and sequence chart, refer to Fig. 2 and 3.
2. For remote wiring of the Keyboard Display Module, refer to the Specifications for the Keyboard Display Module (65-0288), Network Interface Unit (63-2278), Data ControlBus™ Module (65-0091) or Extension Cable Assembly (65-0131).
3. Disconnect the power supply from the main disconnect before beginning installation to prevent electrical shock and equipment damage. More than one disconnect can be required.
4. All wiring must comply with all applicable electrical codes, ordinances and regulations. Wiring, where required, must comply with NEC, Class 1 (Line Voltage) wiring.
5. For recommended wire size and type, see Table 1.
6. For recommended grounding practices, see Table 2.

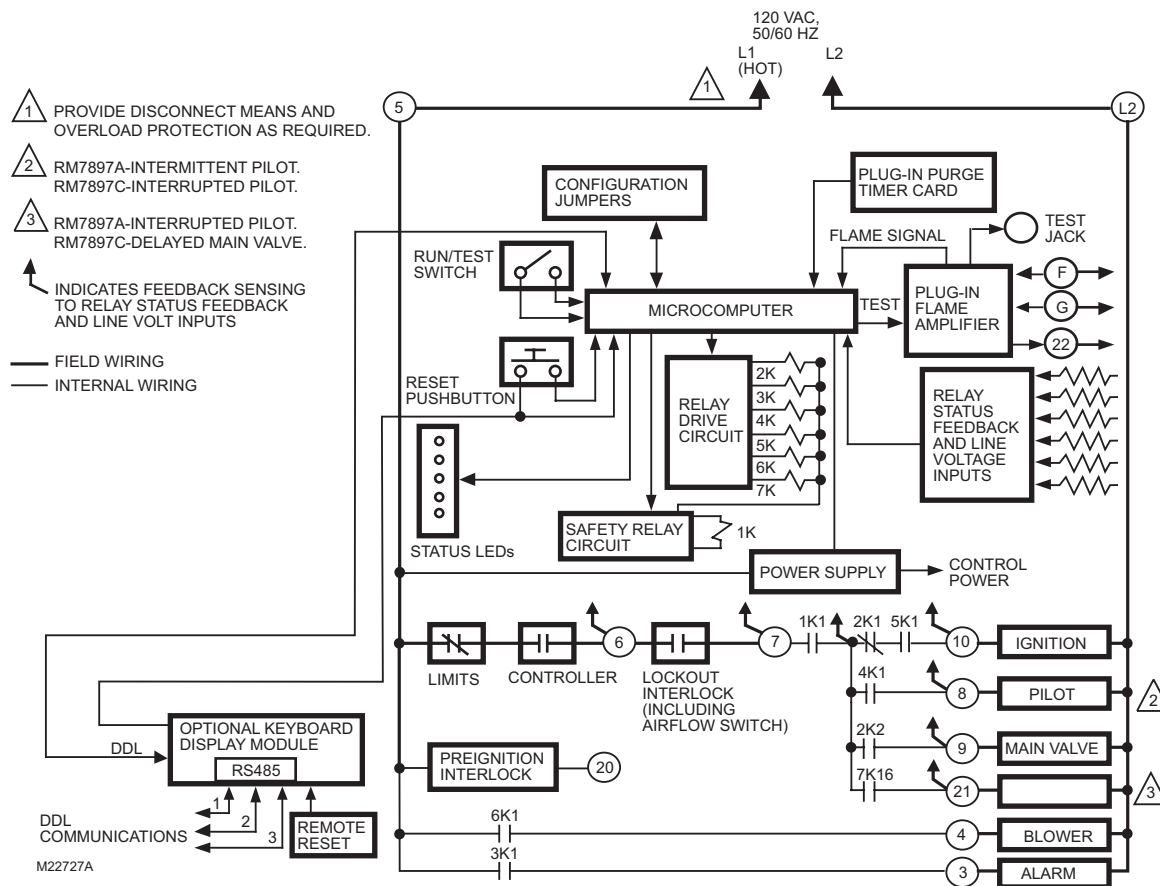
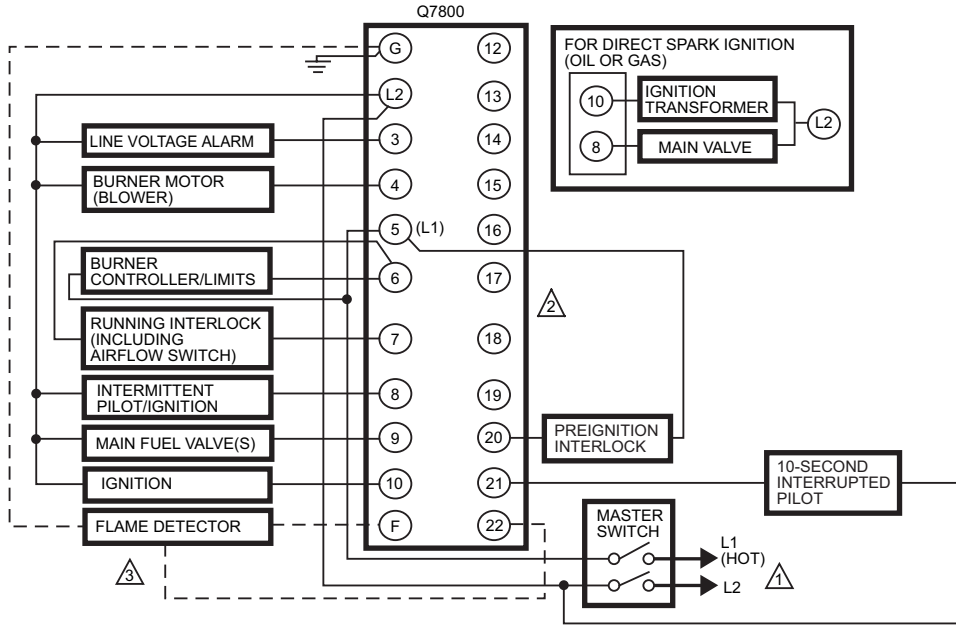

Fig. 1. Internal block diagram of RM7897A,C (see Fig. 2 and 3 for detailed wiring instructions).

7. Recommended wire routing of leadwires:
 - a. Do not run high voltage ignition transformer wires in the same conduit with the flame detector, Data ControlBus Module™, or Remote Reset Module wiring.
 - b. Do not route flame detector, Data ControlBus™ Module, or Remote Reset Module leadwires in conduit with line voltage circuits.
 - c. Enclose flame detector leadwires without armor cable in metal cable or conduit.
 - d. Follow directions in flame detector, Data ControlBus™ Module, or Remote Reset Module Instructions.
 8. The KDM is powered from a low voltage, energy limited source. It can be mounted outside of a control panel if it is protected from mechanical damage.
- NOTE:** A 13 Vdc power supply must be used any time more than one KDM is used.



| | INITIATE (INITIAL POWERUP ONLY) | STANDBY | 00 TIMED PREPURGE | 00 PFEP 10 SEC. (4 SEC. IF JR1 CLIPPED) | 10 | 20 | 00 POSTPURGE | STANDBY |
|--------------------------------------------|------------------------------------------|---------|-------------------------------------------------|-----------------------------------------------------|---------------|---------|-----------------|---------|
| LED DISPLAY | ● POWER | ● POWER | ● POWER | ● POWER | ● POWER | ● POWER | ● POWER | ● POWER |
| | ○ | ○ | ○ PILOT | ● PILOT | ● PILOT | ● PILOT | ○ | ○ |
| | ○ | ○ | ○ FLAME | ● FLAME | ● FLAME | ● FLAME | ○ | ○ |
| | ○ | ○ | ○ MAIN | ○ MAIN | ● MAIN | ● MAIN | ○ | ○ |
| BURNER | | | BURNER/BLOWER MOTOR (5) | | | | | |
| | | | (10) | IGN. | | | | |
| | | | | INTERMITTENT PILOT (8) | | | | |
| | | | | INTERRUPTED PILOT (21) | | | | |
| OPERATING CONTROLS AND INTERLOCKS | | | | MAIN VALVE (9) | | | | |
| | | | LIMITS AND BURNER CONTROLLER CLOSED (L1) TO (6) | | | | | |
| | | | RUNNING INTERLOCKS CLOSED (6) TO (7) | | | | | |
| FLAME SIGNAL | | | PREIGNITION INTERLOCK CLOSED (5) TO (20) | | | | PII | |
| | | | SAFE START CHECK | | FLAME PROVING | | | SSC |

⚠ 120 VAC, 50/60 HZ POWER SUPPLY. PROVIDE DISCONNECT MEANS AND OVERLOAD PROTECTION AS REQUIRED.

⚠ DO NOT CONNECT ANY WIRES TO UNUSED TERMINALS.

⚠ SEE FLAME DETECTOR SPECIFICATIONS FOR CORRECT WIRING.

⚠ PROGRAMMED ON SETUP USING S7800A1142 DISPLAY.

⚠ PURGE TIME DEPENDS ON WHICH ST7800 IS INSTALLED.

M22728B

Fig. 2. Wiring subbase and sequence chart for RM7897A.

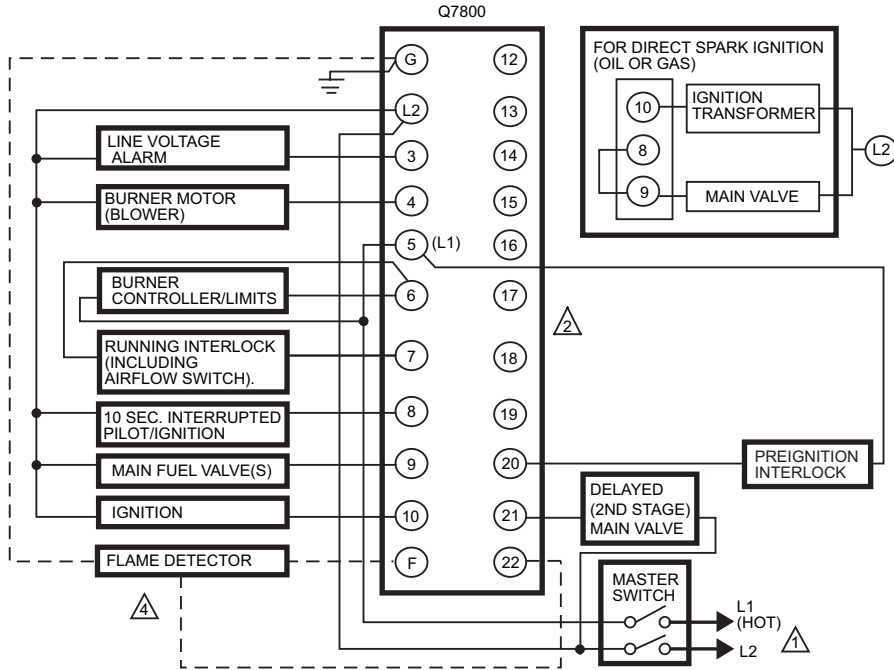

| | INITIATE (INITIAL POWERUP ONLY) | STANDBY | 00 TIMED ⁵ 00 PREPURGE | 10 SEC. (4 SEC. IF JR1 CLIPPED) MFEP | 20 | 00 ³ POSTPURGE, STANDBY | |
|------------------------------------------|---------------------------------|-----------------------------|----------------------------------------------------|----------------------------------------------------|----------------------------------------------------|----------------------------------------------------|-----------------------------|
| LED DISPLAY | ● POWER ○ ○ ○ ○ | ● POWER ○ ○ ○ ○ | ● POWER ○ PILOT ○ FLAME ○ MAIN ○ ALARM | ● POWER ● PILOT ● FLAME ○ MAIN ○ ALARM | ● POWER ● PILOT ● FLAME ● MAIN ○ ALARM | ● POWER ○ PILOT ○ FLAME ○ MAIN ○ ALARM | ● POWER ○ ○ ○ ○ |
| BURNER | | | | | | | |
| | | | | | 5 | | |
| | | | 10 | | | | |
| | | | | 8 | | | |
| | | | | | 9 | | |
| | | | | | 21 | | |
| OPERATING CONTROLS AND INTERLOCKS | | | | | | | |
| | | | | L1 TO 6 | | | |
| | | | | 6 TO 7 | | | |
| | | | | 5 TO 20 | | PII | |
| FLAME SIGNAL | | | | | | | |
| | | | | | | SSC | |

⚠ 120 VAC, 50/60 HZ POWER SUPPLY. PROVIDE DISCONNECT MEANS AND OVERLOAD PROTECTION AS REQUIRED.

⚠ DO NOT CONNECT ANY WIRES TO UNUSED TERMINALS.

⚠ PROGRAMMABLE POST PURGE TIMING USING S7800A1142 KDM.

⚠ SEE FLAME DETECTOR SPECIFICATIONS FOR CORRECT WIRING.

⚠ PURGE TIME DEPENDS ON WHICH ST7800 IS INSTALLED.

M22729A

Fig. 3. Wiring subbase and sequence chart for RM7897C.

Table 1. Recommended Wire Sizes and Part Numbers.

| Application | Recommended Wire Size | Recommended Part Numbers |
|----------------------------------------------------------|----------------------------------------------------------------------------------|-------------------------------------------|
| Line voltage terminals. | 14, 16 or 18 AWG copper conductor, 600 volt insulation, moisture-resistant wire. | TTW60C, THW75C, THHN90C. |
| Keyboard Display Module | 22 AWG two-wire twisted pair with ground, or five-wire. | Belden 8723 shielded cable or equivalent. |
| Data ControlBus™ Module ^a | 22 AWG two-wire twisted pair with ground, or five-wire. | Belden 8723 shielded cable or equivalent. |
| Remote Reset Module | 22 AWG two-wire twisted pair, insulated for low voltage. | — |
| Communications Interface ControlBus™ Module ^a | 22 AWG two-wire twisted pair with ground. | Belden 8723 shielded cable or equivalent. |
| 13 Vdc full-wave rectified transformer power input. | 18 AWG wire insulated for voltages and temperatures for given application. | TTW60C, THW75C, THHN90C. |

^a The KDM, Data ControlBus™ Module (for remote mounting or communications) or Communication Interface ControlBus™ Module must be wired in daisy chain configuration, 1(a)-1(a), 2(b)-2(b), 3(c)-3(c). The order of interconnection of all the devices listed above is not important. Be aware that modules on the closest and farthest end of the daisy chain configuration string require a 120 ohm (1/4 watt minimum) resistor termination across terminals 1 and 2 of the electrical connectors for connections over 100 feet (31 meters).

Table 2. Recommended Grounding Practices.

| Ground Type | Recommended Practice |
|----------------------------------------------------------------------------------------------------------------|---------------------------------------------------------------------------------------------------------------------------------------------------------------------------------------------------------------------------------------------------------------------------------------------------------------------------------------------------------------------------------------------------------------------------------------------------------------------------------------------------------------------------------------------------------------------------------------------------------------------------------------------|
| Earth ground (subbase and relay module). | <ol style="list-style-type: none"> 1. Use to provide a connection between the subbase and the control panel of the equipment. Earth ground must be capable of conducting enough current to blow the 15A, type SC, fast blow fuse (or breaker) in the event of an internal short circuit. 2. Use wide straps or brackets to provide minimum length, maximum surface area ground conductors. If a leadwire is required, use 14 AWG copper wire. 3. Make sure that mechanically tightened joints along the ground path are free of nonconductive coatings and protected against corrosion on mating surfaces. |
| Signal ground (Keyboard Display Module, Data ControlBus™ Module, Communications Interface ControlBus™ Module). | Use the shield of the signal wire to ground the device to the signal ground terminal 3(c) of each device. Connect the shield at both ends of the daisy chain to earth ground. |

9. Maximum wire lengths:
 - a. RM7897A,C leadwires: The maximum leadwire length is 300 feet to terminal inputs (Control, Running/Lockout Interlock).
 - b. Flame Detector leadwires: The maximum flame sensor leadwire length is limited by the flame signal strength.
 - c. Remote Reset leadwires: The maximum length of wire is 1000 feet (305 meters) to a Remote Reset push button.
 - d. Data ControlBus Module™: The maximum Data ControlBus™ Module cable length depends on the number of system modules connected, the noise conditions and the cable used. The maximum length of all Data ControlBus™ Module interconnecting wire is 4000 feet (1219 meters).

10. Be sure loads do not exceed the terminal ratings. Refer to the label on the RM7897A,C or to the terminal ratings in Table 3.

Final Wiring Check

1. Check the power supply circuit. The voltage and frequency tolerance must match those of the RM7897A,C. A separate power supply circuit can be required for the RM7897A,C. Add the required disconnect means and overload protection.
2. Check all wiring circuits and complete Static Checkout in Table 6 before installing the RM7897A,C on the subbase.
3. Install all electrical connectors.
4. Restore power to the panel.

STATIC CHECKOUT

external controllers, limits, interlocks, actuators, valves, transformers, motors and other devices are operating properly.

After checking all wiring, perform this checkout before installing the RM7897A,C on the subbase. These tests verify the Q7800 Wiring Subbase is wired correctly, and the

Table 3. Terminal Ratings.

| Terminal Number | Description | Ratings |
|-----------------|--------------------------------|------------------------------------------------------|
| | | RM7897A,C |
| G | Flame Sensor Ground | — |
| Earth G | Earth Ground ^a | — |
| L2(N) | Line Voltage Common | — |
| 3 | Alarm | 120 Vac, 1A pilot duty. |
| 4 | Burner Motor | 120 Vac, 9.8A AFL, 58.8 ALR (inrush). |
| 5 | Line Voltage Supply (L1) | 120 Vac (+10/-15%), 50 or 60 Hz (±10%). ^b |
| 6 | Burner Controller and Limits | 120 Vac, 1 mA. |
| 7 | Lockout Interlock | 120 Vac, 8A run, 43A inrush. |
| 8 | Pilot Valve/Ignition | 120 Vac ^c |
| 9 | Main Fuel Valve | 120 Vac ^c |
| 10 | Ignition | 120 Vac ^c |
| F(11) | Flame Sensor | 60 to 220 Vac, current limited. |
| 12 to 19 | — | — |
| 20 | Prelgnition Interlock | 120 Vac, 1 mA. |
| 21 | Interrupted Pilot (RM7897A) | 120 Vac |
| 21 | 2nd Stage Main Valve (RM7897C) | 120 Vac ^c |
| 22 | Shutter | 120 Vac, 0.5A |

^a See Table 2.

^b 2000 VA maximum load connected to RM7897A,C Assembly.

^c See Tables 4 and 5.

Table 4. Combinations for Terminals 8, 9, 10 and 21.

| Combination Number | Pilot Fuel 8 | Main 9 | Ignition 10 | Delayed Main Valve 21 (RM7897A Only) | Delayed Main Valve 21 (RM7897C Only) |
|--------------------|----------------|---------|-------------|--------------------------------------|--------------------------------------|
| 1 | C | F | No Load | C | No Load |
| 2 | B | F | No Load | B | No Load |
| 3 | F ^a | F | A | F | No Load |
| 4 | F | F | A | F | No Load |
| 5 | F ^a | F | A | F | F |
| 6 | D | F | A | D | No Load |
| 7 | D ^a | D | A | D | D |
| 8 | D | D | A | D | No Load |
| 9 | D ^a | No Load | A | D | D |

^a RM7897C only, jumper terminals 8 to 9.

Table 5. Composition of each Combination.

| A | B | C | D | F |
|---------------|--------------------------------------|----------------------------------------------------------------------------------|---------------|------------------------------------------------------------------------------------|
| 4.5A ignition | 50 VA Pilot Duty plus 4.5A ignition. | 180 VA Ignition plus motor valves with: 660 VA inrush, 360 VA open, 240 VA hold. | 2A Pilot Duty | 65 VA Pilot Duty plus motor valves with: 3850 VA inrush, 700 VA open, 250 VA hold. |

WARNING

Fire or Explosion Hazard.

Can cause property damage, severe injury or death.

Close all manual fuel shutoff valve(s) before starting these tests.

Use extreme care while testing the system. Line voltage is present on most terminal connections when power is on.

Ensure proper selection of configuration jumpers before starting the burner operation.

CAUTION

Electrical Hazard.

Can cause equipment damage or failure.

Do not perform a dielectric test with the relay module installed. Internal surge protectors can break down, allowing relay module to fail the dielectric test and destroy the internal lightning and high current protection.

1. Open the master switch before installing or removing a jumper on the subbase.
2. Before continuing to the next test, be sure to remove the test jumper(s) used in the previous test.
3. Replace all limits and interlocks that are not operating properly. Do not bypass limits and interlocks.

Equipment Recommended

1. Voltmeter (1M ohm/volt minimum sensitivity) set on the 0 to 300 Vac scale.
2. Two jumper wires, no. 14 wire, insulated, 12 in. (304.8 mm) long with insulated alligator clips at both ends.

General Instructions

1. Perform all applicable tests listed in Static Checkout, Table 6, in the order listed.
2. Make sure all manual fuel shutoff valve(s) are closed.
3. For each test, open the master switch and install the jumper wire(s) between the subbase wiring terminals listed in the Test Jumpers column.
4. Close the master switch before observing operation.
5. Read the voltage between the subbase wiring terminals listed in the Voltmeter column.

6. If there is no voltage or the operation is abnormal, check the circuits and external devices as described in the last column.
7. Check all wiring for correct connections, tight terminal screws, correct wire, and proper wiring techniques. Replace all damaged or incorrectly sized wires.
8. Replace faulty controllers, limits, interlocks, actuators, valves, transformers, motors and other devices, as required.
9. Make sure normal operation is obtained for each required test before continuing the checkout.
10. After completing each test, be sure to open the master power switch and remove the test jumper(s) before proceeding to the next test.

WARNING

Explosion hazard.

Can cause serious injury or death.

Be sure all manual fuel shutoff valves are closed.

Mounting RM7897A,C Relay Module

1. Mount the RM7897A,C vertically on the Q7800 Subbase or mount horizontally with the knife blade terminals pointing down. When mounted on the Q7800A, the RM7897A,C must be in an electrical enclosure.
2. When mounting in an electrical enclosure, provide adequate clearance for servicing, installation and removal of the RM7897A,C, KDM, flame amplifier, flame amplifier signal voltage probes, electrical signal voltage probes and electrical connections.
 - e. Allow an optional three-inch (76 mm) minimum on both sides of the RM7897A,C for electrical signal voltage probes.
3. Make sure no subbase wiring is projecting beyond the terminal blocks. Tuck in wiring against the back of the subbase so it does not interfere with the knife blade terminals or bifurcated contacts.

IMPORTANT

The RM7897A,C, must be installed with a plug-in motion rather than a hinge action.

4. Mount the RM7897A,C by aligning the four L-shaped corner guides and knife blade terminals with the bifurcated contacts on the wiring subbase and securely tightening the two screws without deforming the plastic.

Table 6. Static Checkout.

| Test Number | Relay Module Model | Test Jumpers | Voltmeter | Normal Operation | If Operation is Abnormal, Check Items Listed Below |
|-------------|--------------------|-----------------------------------------------------------------------------------------------------------------------------------------------------------------------------------------------------------------------------------------------------------------------------------------------------------------------------------------------------|-----------|------------------------------------------------------------------------------------------------------------------------------------------------------------------------------------------------------|-----------------------------------------------------------------------------------------------------------------------------------------------------|
| 1 | All | None | 5-L2 | Line voltage at terminal 5. | 1. Master switch. 2. Power connected to master switch. 3. Overload protection (fuse, circuit breaker, etc.) has not opened power line. |
| 2 | All | None | 6-L2 | Line voltage at terminal 6. | 1. Limits. 2. Burner controller. |
| 3 | All | 4-5 | 7-L2 | 1. Burner motor (fan or blower) starts. 2. Line voltage at terminal 7 within 10 seconds. | 1. Burner motor circuit. a. Manual switch of burner motor. b. Burner motor power supply, overload protection and starter. c. Burner motor. |
| 4 | All | 5-10 | — | 1. Ignition spark (if ignition transformer is connected to terminal 10). | 1. Watch for spark or listen for buzz. a. Ignition electrodes are clean. b. Ignition transformer is okay. |
| 5 | All | | 20-L2 | Line voltage at Terminal 20 | Preignition Interlocks. |
| 6 | All | 5-8 | — | 1. Ignition spark (if ignition transformer is connected to terminal 8). 2. Automatic pilot valve opens (if connected to terminal 8). NOTE: Refer to wiring diagram of system being tested. | 1. Watch for spark or listen for buzz. 2. Listen for click or feel head of valve for activation. a. Actuator if used. b. Pilot valve. |
| 7 | All | 5-9 | — | Automatic fuel valve(s) open(s). If using direct spark ignition, check first stage fuel valve(s) instead of pilot valve. | Same as test 6. If using direct spark ignition, check first stage fuel valve(s) instead of pilot valve. |
| 8a | RM7897A | 5-21 | — | 1. Ignition spark (if ignition connected to terminal 21). 2. Automated Pilot Valve opens (if connected to terminal 21). NOTE: Refer to wiring diagram of system being tested. | 1. Watch for spark or listen for buzz. 2. Listen for click or feel head of valve for activation. a. Actuator if used. b. Pilot valve. |
| 8b | RM7897C | 5-21 | — | Automatic second stage main fuel valve(s) open(s). | 1. Listen for and observe operation of second stage main fuel valve(s) and actuator(s). 2. Valve(s) and actuator(s). |
| 9 | All | 5-3 | — | Alarm (if used) turns on. | 1. Alarm. |
| Final | All |  <p>CAUTION Equipment Damage Hazard. Can cause equipment damage. After completing these tests, open master switch and remove all test jumpers from subbase terminals. Also remove bypass jumpers, if used, from low fuel pressure limits.</p> | | | |

Mounting Other System Components (Fig. 4)

Refer to the applicable specifications for mounting other system components.

Setup of Post Purge

An S7800A1142, Keyboard Display Module (KDM), is required for the setup of the RM7897 Post Purge Timing, and must be purchased separately.

When the RM7897A,C is installed and powered, “**STANDBY**” will be shown on the first line of the display (Fig. 5).

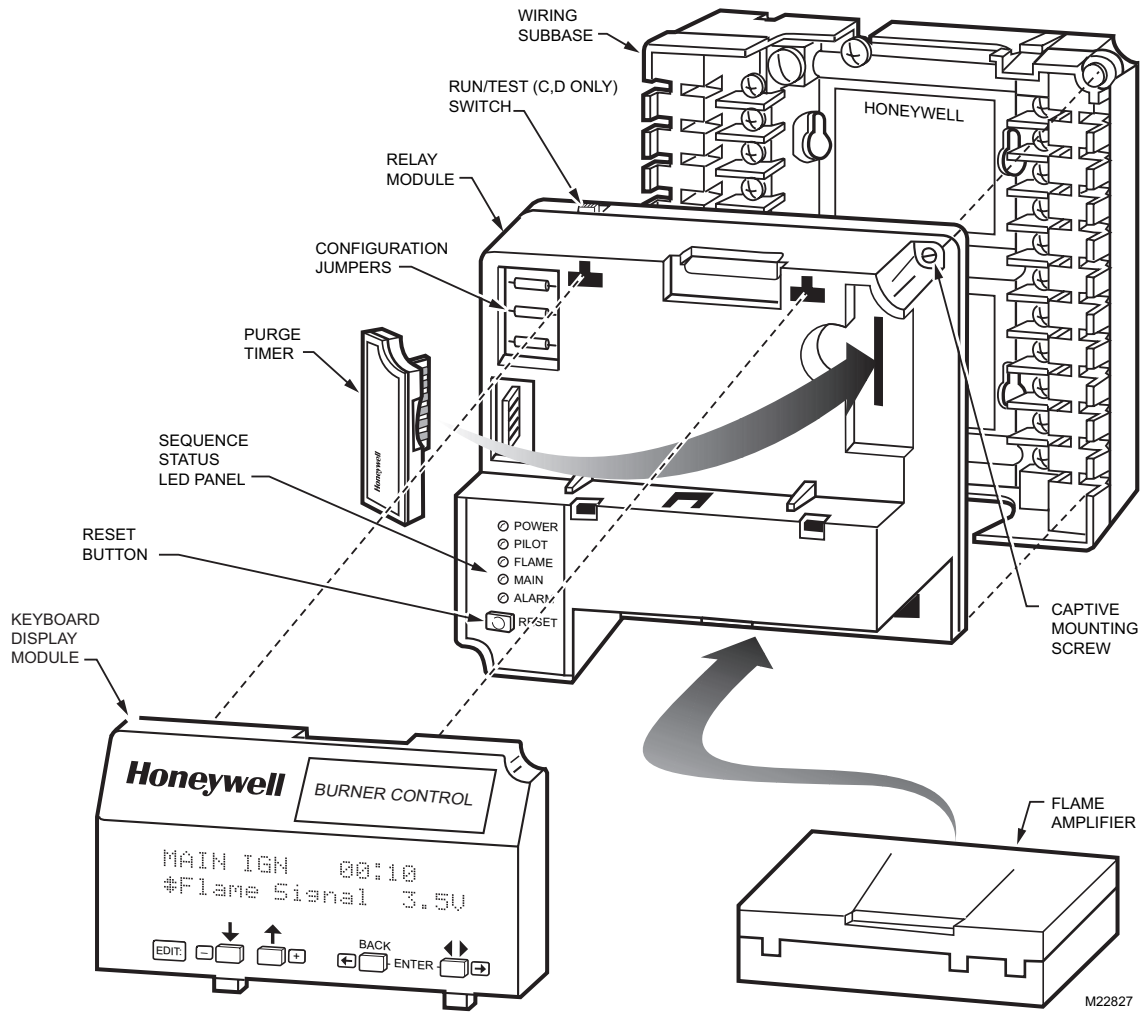

Fig. 4. RM7897A,C Relay Module, exploded view.

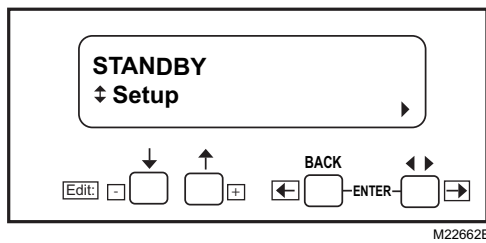

Fig. 5. Setup Needed screen.

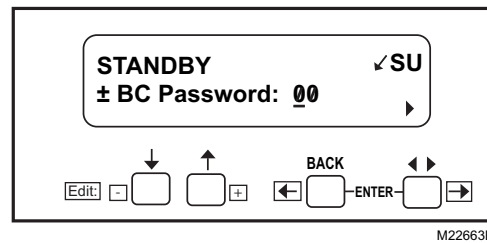

Fig. 6. Entering the setup sub-routine.

1. Scroll down until "Setup" is displayed in the second line.
2. Enter the setup sub-routine by pressing the far right arrow key on the display.

The second line reads "BC Password".

3. Use the up/down arrows to enter the first number, 7.
4. Use the far right arrow key to shift over one space.
5. Use the up/down arrows to enter the second number, 8.
6. Press Enter (left/right arrow simultaneously).

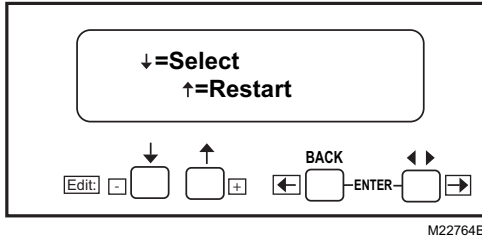

Fig. 7. Select/Restart screen.

7. Press down arrow to select.
8. "Getting Data" will be momentarily displayed, followed by the screen shown in Fig. 8.

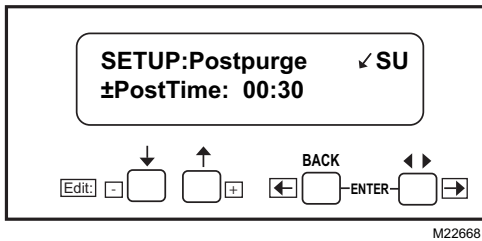

Fig. 8. Setting Post Purge time.

This screen allows for setting up the Postpurge for the RM7897A,C. This will be the time that the Combustion Fan (terminal 4) will remain energized after the call for heat has ended (terminal 6).

9. Use the up arrow to increase the postpurge time. Time increases:

- 0 to 60 seconds in 1 second intervals.
- 60 to 600 seconds in 10 second intervals.
- 10 to 60 minutes in 1 minute intervals.

10. Press Enter (Left/Right arrow keys simultaneously) when the correct postpurge time is displayed.

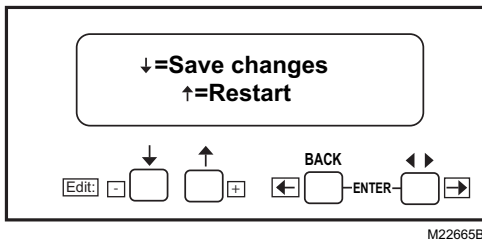

Fig. 9. Save Changes screen.

11. Use the down arrow to save changes. "Getting Data" is displayed momentarily. The following steps are used to confirm your selection.

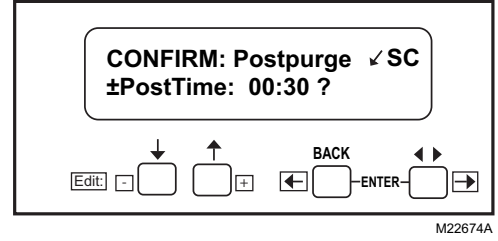

Fig. 10. Confirm Postpurge time.

1. Press Enter.

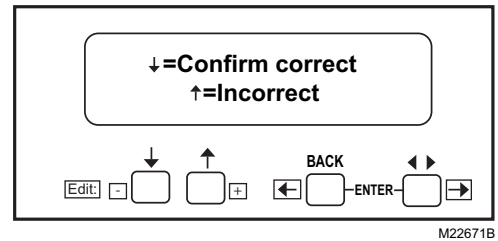

Fig. 11. Confirm correct/incorrect screen.

2. Press the down arrow to confirm the correct postpurge time. "Getting Data" will be displayed until the screen in Fig. 12 appears.

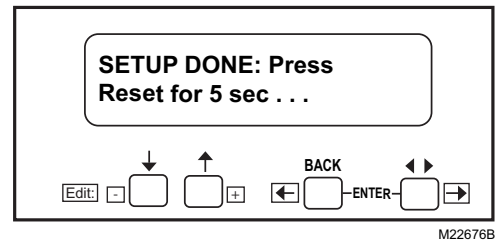

Fig. 12. Setup Done screen.

3. Go to the RM7897 and press and hold the reset button for five seconds to program the postpurge time into the relay module. The Release Reset screen will appear on the KDM.

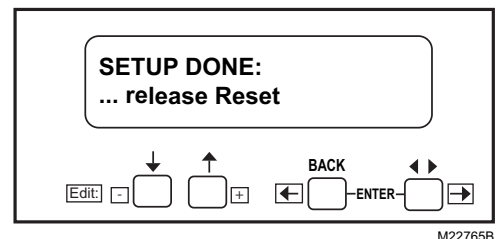

Fig. 13. Release Reset screen.

Changing the postpurge time feature is still possible. With the RM7897 in Standby, scrolling to the Setup line and entering with the password allows the settings to be changed.

Once the system is in operation, the settings of the postpurge time can be viewed under Diagnostics, using your S7800 Keyboard Display Module.

PRINCIPAL TECHNICAL FEATURES

The RM7897 provides all customary flame safeguard functions as well as significant advancements in safety, annunciation, and system diagnostics.

Safety Shutdown (Lockout) Occurs if:

1. INITIATE PERIOD
 - a. Purge card is not installed or removed.
 - b. Purge card is bad.
 - c. Configuration jumpers have been changed (after 200 hours)—Fault Code 110.
 - d. AC line power errors occurred, see Operation.
 - e. Four minute INITIATE period has been exceeded.
2. STANDBY PERIOD
 - a. Airflow lockout feature is enabled and the airflow switch does not close after ten seconds or within the specified purge card timing.
 - b. Flame signal is detected after 240 seconds.
 - c. Ignition/pilot valve terminal is energized.
 - d. Main valve terminal is energized.
 - e. Delayed main valve terminal is energized (RM7897C).
 - f. Internal system fault occurred.
 - g. Purge card is removed.
 - h. Purge card is bad.
 - i. Preignition Interlock open.
3. PREPURGE PERIOD
 - a. Airflow lockout feature is enabled and the airflow switch opens.
 - b. Ignition/pilot valve terminal is energized.
 - c. Main valve terminal is energized.
 - d. Delayed main valve terminal is energized (RM7897C).
 - e. Internal system fault occurred.
 - f. Purge card is removed.
 - g. Purge card is bad.
 - h. Flame signal is detected for 30 seconds.
 - i. Preignition interlocks open during standby.
4. PILOT FLAME ESTABLISHING PERIOD (PFEP)
 - a. Airflow lockout feature is enabled and the airflow switch opens.
 - b. No flame signal at end of PFEP.
 - c. Ignition/pilot valve/intermittent pilot valve terminal is not energized.
 - d. Main valve terminal is energized (RM7897A).
 - e. Delayed (second stage) main valve terminal is energized (RM7897C).
 - f. Internal system fault occurred.
 - g. Purge card is removed.
 - h. Purge card is bad.
5. MAIN FLAME ESTABLISHING PERIOD (MFEP) (RM7897A, terminal 21; RM7897C, terminal 8)
 - a. Airflow lockout feature is enabled and the airflow switch opens.
 - b. Ignition terminal is energized.
 - c. Ignition/pilot valve terminal is not energized.
 - d. Main valve terminal is not energized.
 - e. Delayed main valve terminal is energized.

- f. Loss of flame signal.
- g. Internal system fault occurred.
- h. Purge card is removed.
- i. Purge card is bad.
6. RUN PERIOD
 - a. No flame present (JR2 removed).
 - b. Airflow lockout feature is enabled and the airflow switch opens.
 - c. Interrupted pilot valve terminal is energized (RM7897A, terminal 21; RM7897C, terminal 8).
 - d. Main valve terminal is not energized.
 - e. Delayed main valve terminal is not energized (RM7897C).
 - f. Internal system fault occurred.
 - g. Purge card is removed.
 - h. Purge card is bad.
 - i. Ignition terminal is energized.

OPERATION

Sequence of Operation

The RM7897A,C has the operating sequences listed below; see Fig. 2 and 3. The RM7897A,C LED provide positive visual indication of the program sequence: POWER, PILOT, FLAME, MAIN and ALARM.

Initiate

The RM7897A,C Relay Module enters the INITIATE sequence when the relay module is powered. The RM7897A,C can also enter the INITIATE sequence if the relay module verifies voltage fluctuations of +10/-15% or frequency fluctuations of $\pm 10\%$ during any part of the operating sequence. The INITIATE sequence lasts for ten seconds unless the voltage or frequency tolerances are not met. When not met, a hold condition is initiated and displayed on the optional KDM for at least five seconds; when met, the INITIATE sequence restarts. If the condition is not corrected and the hold condition exists for four minutes, the RM7897A,C locks out. Causes for hold conditions in the INITIATE sequence:

1. AC line dropout detection.
2. AC line noise that can prevent a sufficient reading of the line voltage inputs.
3. Low line voltage brownouts.

The INITIATE sequence also delays the burner motor starter from being energized and de-energized from an intermittent AC line input or control input.

Standby

The RM7897A,C is ready to start an operating sequence when the operating control input determines a call for heat is present. The burner switch, limits, operating limit control and all microcomputer-monitored circuits must be in the correct state for the relay module to continue into the PREPURGE sequence.

Normal Start-Up Prepurge

The RM7897A,C Relay Module provides PREPURGE timing, selectable with ST7800 Purge Timer cards, from two seconds to thirty minutes with power applied and the operating control indicating a call for heat.

1. The Airflow Interlock, burner switch, Run/Test switch and all microcomputer-monitored circuits must also be in the correct operating state.
2. The motor output, terminal 4, is powered to start the PREPURGE sequence.
3. The Airflow Interlock input closes ten seconds into PREPURGE or within the specified purge card timing; otherwise, a recycle to the beginning of PREPURGE or lockout occurs, depending on how the Airflow Switch selectable jumper (JR3) is configured.

Ignition Trials

1. Pilot Flame Establishing Period (PFEP):
 - a. When the PFEP begins:
 - (1) The pilot valve and ignition transformer, terminals 8 and 10 (also terminal 21, RM7897A), are energized. The RM7897A has an intermittent pilot valve, terminal 8, and interrupted pilot valve on terminal 21. The RM7897C has an interrupted pilot valve, terminal 8.
 - (2) Flame must be proven by the end of the ten second PFEP (four seconds if Configuration Jumper JR1 is clipped) to allow the sequence to continue. If a flame is not proven by the end of PFEP, a safety shutdown occurs.
 - (3) the Pre-Ignition Interlock is ignored throughout the Trial for Ignition State.
2. Main Flame Establishing Period (MFEP):
 - a. After PFEP, and with the presence of flame, the main fuel valve, terminal 9, is powered. If a flameout occurs, the relay module locks out or recycles (depending on status of jumper JR2) within 0.8 or 3 seconds, depending on the Flame Failure Response Time (FFRT) of the amplifier.
 - b. The RM7897A (terminal 21) and RM7897C (terminal 8) have a ten second MFEP. After the Ignition Trials, the interrupted pilot valve, terminal 8 or 21, is de-energized. If a flameout occurs, the relay module locks out or recycles (depending on status of jumper JR2) within 0.8 or 3 seconds, depending on the Flame Failure Response Time (FFRT) of the amplifier.

Run

1. The RM7897C has a delayed main valve that is energized once the RUN period is entered.
2. The relay module is now in RUN and remains in RUN until the controller input, terminal 6, opens, indicating that the demand is satisfied or a limit has opened.

Post Purge

After demand is satisfied or a limit opens, de-energizing terminal 6, the Ignition/Pilot valve, main valve and delayed main valve, terminals 8, 9 and 21, are de-energized. The blower motor, terminal 4, remains powered during the specified programmed time. The Pre-Ignition Interlock closes within the first five seconds of Post Purge.

Run/Test Switch

The Run/Test Switch is located on the top side of the relay module, see Fig. 12. The Run/Test Switch allows the burner sequence to be altered as follows:

1. In the measured PREPURGE sequence, the Run/Test Switch, placed in the TEST position, causes the PREPURGE timing to stop.
2. In the Pilot Flame Establishing Period, the Run/Test Switch, placed in the TEST position, stops the timer during the first eight seconds of a ten-second PFEP selection or during the first three seconds of a four-second PFEP selection. It also allows for pilot turn-down test and other burner adjustments. This activates a fifteen-second flameout timer that permits pilot flame adjustment without nuisance safety shutdowns. The Run/Test Switch is ignored during PFEP for the C relay module if terminals 8 and 9 or 9 and 21 are jumpered.

IMPORTANT

When the relay module is switched to the TEST mode, it stops and holds at the next Run/Test Switch point in the operating sequence. Make sure that the Run/Test Switch is in the RUN position before leaving the installation.

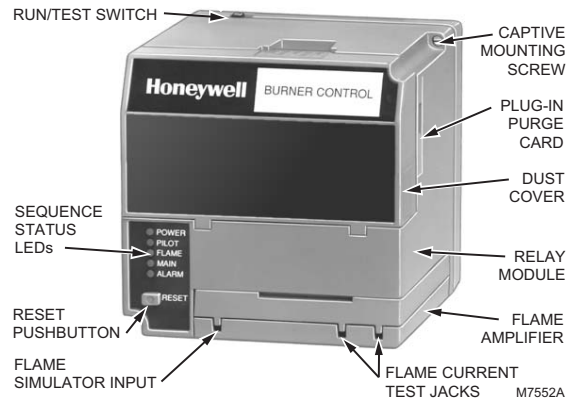

Fig. 14. Sequence Status LEDs.

SETTINGS AND ADJUSTMENTS

Selectable Site-Configurable Jumpers

The relay module has three site-configurable jumper options, see Fig. 13 and Table 7. If necessary, clip the site-configurable jumpers with side cutters and remove the resistors from the relay module.

SERVICE NOTE: Clipping and removing a site-configurable jumper enhances the level of safety.

IMPORTANT

Clipping and removing a jumper after 200 hours of operation causes a nonresettable Fault 110. The relay module must then be replaced.

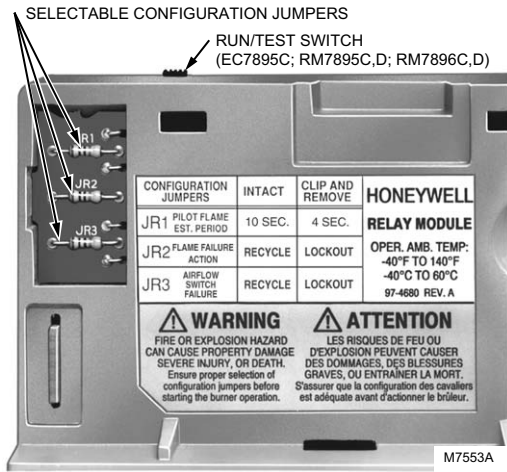

Fig. 15. Selectable site-configurable jumpers.

Table 7. Site-configurable jumper options.

| Jumper Number | Description | Intact | Clipped |
|---------------|----------------------------------------|------------|-----------|
| JR1 | Pilot Flame Establishing Period (PFEP) | 10 seconds | 4 seconds |
| JR2 | Flame Failure Action | Recycle | Lockout |
| JR3 | Airflow Switch (ILK) Failure | Recycle | Lockout |

TROUBLESHOOTING

The POWER LED provides fault identification when the Relay Module locks out on an alarm. Fault identification is a series of fast- and slow-blinking LED lights. The fast blinks identify the tens portion of the fault code (three fast blinks is 30), while the slow blinks identify the units portion of the fault code (two slow blinks is 2). Three fast blinks followed by two slow blinks would be fault code 32. This identifies a running interlock on during STANDBY. (See Table 8 for Blinking Fault Code List.)

The LED code repeats as long as the fault exists. To clear the fault, press the RESET button.

Table 8. Blinking Fault Codes and Recommended Troubleshooting.

| Fault Code | System Failure | Recommended Troubleshooting |
|---------------------------------------|----------------------------------------------------------------------------------------------------------------------------------------|----------------------------------------------------------------------------------------------------------------------------------------------------------------------------------------------------------------------------------------------------------------------------------------------------------------------------------------------------------------------------------------------------------------------------------------------------------------------------------------------------------------------------------------------------------------------------------------------------------------------------------------------------------------------------------------------------------------------------------------------------------------------------------------------------------------------------------------------------------------------------------------------------------------------------------------------------------------------------------------------------|
| Code 1-1 *Low AC Line Voltage* | Low AC Line detected. | <ol style="list-style-type: none"> 1. Check the relay module and display module connections. 2. Reset and sequence the Relay Module. 3. Check the 7800 power supply and make sure that frequency and voltage meet specifications. 4. Check the backup power supply, as appropriate. |
| Code 1-2 *AC Quality Problem* | Excessive noise or device running on slow, fast, or AC line dropout detected. | |
| Code 2-1 *Unexpected Flame Signal* | Flame sensed when no flame is expected during STANDBY or PURGE. | <ol style="list-style-type: none"> 1. Check that flame is not present in the combustion chamber; correct any errors. 2. Make sure that the flame amplifier and flame detector are compatible. 3. Check the wiring and correct any errors. 4. Remove the flame amplifier and inspect its connections. Reseat the amplifier. 5. Reset and sequence the relay module. 6. If the code reappears, replace the flame amplifier and/or the flame detector. 7. If the fault persists, replace the relay module. |
| Code 2-2 *Flame Signal Absent* | No-flame time present at the end of the Pilot Flame Establishing Period; lost during the Main Flame Establishing Period or during RUN. | <ol style="list-style-type: none"> 1. Measure the flame signal. If one exists, verify that it meets specifications. 2. Make sure that the flame amplifier and flame detector are compatible. 3. Inspect the main fuel valve(s) and valve connection(s). 4. Verify that the fuel pressure is sufficient to supply fuel to the combustion chamber. Inspect the connections to the fuel pressure switches. Make sure they are functioning properly. 5. Inspect the Airflow Switch and make sure that it is functioning properly. 6. Check the flame detector sighting position; reset and recycle. Measure the flame signal strength. Verify that it meets specifications. If not, refer to the flame detector and/or flame amplifier checkout procedures in the installation instructions. 7. Replace the flame amplifier and/or the flame detector, if necessary. 8. If the fault persists, replace the relay module. |

Table 8. Blinking Fault Codes and Recommended Troubleshooting. (Continued)

| Fault Code | System Failure | Recommended Troubleshooting |
|----------------------------------------------------|-----------------------------------------------------------------------------------------------------|--------------------------------------------------------------------------------------------------------------------------------------------------------------------------------------------------------------------------------------------------------------------------------------------------------------------------------------------------------------------------------------------------------------------------------------------------------------------------------------------------------------------------------------------------------------------------------------------------------------------------------------------------------------------------------------------------------------------------------------------------------------------------------------------------------|
| Code 2-3 *Flame Signal Overrange* | Flame signal value is too high to be valid. | <ol style="list-style-type: none"> 1. Make sure the flame detector and flame amplifier are compatible. 2. Remove the flame amplifier and inspect its connections. Reset the flame amplifier. 3. Reset and sequence the relay module. 4. Check the flame detector sighting position; reset and recycle. Measure flame strength. Verify that it meets specifications. If not, refer to the flame detector and/or flame amplifier checkout procedures in the installation instructions. 5. If the code reappears, replace the flame amplifier and/or the flame detector. 6. If the fault persists, replace the relay module. |
| Code 3-1 *Running/ Interlock Switch Problem* | Running or Lockout Interlock fault during Prepurge. | <ol style="list-style-type: none"> 1. Check wiring; correct any errors. 2. Inspect the fan; make sure there is no air intake blockage and that it is supplying air. 3. Make sure the Lockout Interlock switches are functioning properly and the contacts are free from contaminants. 4. Reset and sequence the relay module to Prepurge (place the TEST/RUN Switch in the TEST position, if available). Measure the voltage between terminal 7 and G (ground); 120 Vac should be present. Switch TEST/RUN back to RUN. 5. If steps 1 through 4 are correct and the fault persists, replace the relay module. |
| Code 3-2 *Running/ Interlock On During Standby* | Lockout Interlock powered at improper point in sequence or On in Standby. | <ol style="list-style-type: none"> 1. Check wiring to make sure that the Lockout Interlocks are connected properly between terminals 6 and 7. Correct any errors. 2. Reset and sequence the relay module. 3. If the fault persists, measure the voltage between terminal 6 and G (ground), then between terminal 7 and G. If there is 120 Vac at terminal 6 when the controller is off, the controller switch may be bad or is jumpered. 4. If steps 1 through 3 are correct and there is 120 Vac at terminal 7 when the controller is closed and the fault persists, check for a welded or jumpered Running Interlock or Airflow Switch. Correct any errors. 5. If steps 1 through 4 are correct and the fault persists, replace the relay module. |
| Code 3-3 *VPS in Improper State* | VPS (Valve Proving Switch) in wrong state during VPS Test. | <ol style="list-style-type: none"> 1. Check wiring, making sure upstream valve is connected to terminal 9 and downstream valve is connected to terminal 17. 2. Conduct Valve Seat leakage test using a manometer. 3. Reset and sequence the relay module; if fault repeats, test VPS (connected to terminal 16) is functioning properly; replace if necessary. 4. Reset and sequence the relay module. 5. If fault persists, replace the relay module. |
| Code 4-1 *Purge Card Problem* | No purge card or the purge card timing has changed from the original configuration. | <ol style="list-style-type: none"> 1. Make sure the purge card is seated properly. 2. Inspect the purge card and the connector on the relay module for any damage or contaminants. 3. Reset and sequence the relay module. 4. If the fault code reappears, replace the purge card. 5. Reset and sequence the relay module. 6. If the fault code persists, replace the relay module. |
| Code 4-2 *Wiring Problem/ Internal Fault* | Pilot (ignition) valve terminal, main valve, ignition or Main Valve 2 was on when it should be off. | <p>⚠ WARNING Electrical Shock Hazard; Fire or Explosion Hazard. Can cause severe injury, death or property damage. Remove system power and turn off power supply.</p> <ol style="list-style-type: none"> 1. Remove system power and turn off fuel supply. 2. Check wiring; correct any errors. 3. inspect Pilot Fuel Valve(s), both places, and connections. 4. Reset and sequence the relay module. 5. If the fault persists, replace the relay module. |
| Code 4-3 *Flame Amplifier Problem* | Flame not sensed, or sensed when it should be on or off. | <ol style="list-style-type: none"> 1. Check wiring; correct any errors. 2. Make sure the flame amplifier and flame detector are compatible. 3. Remove the flame amplifier and inspect the connections. Reseat the amplifier. 4. Reset and sequence the relay module. 5. If the code reappears, replace the flame amplifier and/or the flame detector. 6. If the fault persists, replace the relay module. |

Table 8. Blinking Fault Codes and Recommended Troubleshooting. (Continued)

| Fault Code | System Failure | Recommended Troubleshooting |
|-----------------------------------------------------|-----------------------------------------------------------------------------|---------------------------------------------------------------------------------------------------------------------------------------------------------------------------------------------------------------------------------------------------------------------------------------------------------------------------------------------------------------------------------------------------------------------------------------------------------------------------------------------------------------------------------------------|
| Code 4-4 *Configuration Jumper Problem* | The configuration jumpers differ from the sample taken at startup. | <ol style="list-style-type: none"> 1. Inspect the jumper connections. Make sure the clipped jumpers were completely removed. 2. Reset and sequence the relay module. 3. If the fault persists, replace the relay module. |
| Code 5-1 *Preignition Interlock* | Preignition Interlock fault. | <ol style="list-style-type: none"> 1. Check wiring and correct any errors. 2. Check Preignition Interlock switches to assure proper functioning. 3. Check fuel valve operation. 4. Reset and sequence the relay module; monitor the Preignition Interlock status. 5. If the fault persists, replace the relay module. |
| Code 5-2 *High Fire Sw. or Low Fire Sw.* | Either High Fire Switch or Low Fire Switch failure. | <ol style="list-style-type: none"> 1. Check wiring and correct any errors. 2. Reset and sequence the relay module. 3. Use manual motor potentiometer to drive the motor open and closed. Verify at motor switch that the end switches are operating properly. Use RUN/TEST switch if manual potentiometer is not available. 4. Reset and sequence the relay module. 5. If the fault persists, replace the relay module. |
| Code 5-3 *Man-Open Sw.; Start Sw. or Control On* | Man-Open Switch, Start Switch or Control On in the wrong operational state. | <ol style="list-style-type: none"> 1. Check wiring and correct any errors. 2. Make sure that the Manual Open Valve Switch, Start Switch and Control are operating properly. 3. Stat Switch held "On" too long. 4. Reset and sequence the relay module. 5. Reset and sequence the relay module. If the fault persists, replace the relay module (RM7838A1014; RM7838B1013 or RM7838C1004 only). |
| Code 6-1 *Internal Faults* | Relay Module self-test failure. | <ol style="list-style-type: none"> 1. Reset and sequence the relay module. 2. If fault reappears, remove power from the device, reapply power, then reset and sequence the relay module. 3. If the fault persists, replace the relay module. |
| Code 6-2 *Internal Faults* | Relay Module Self-Test failure. | <ol style="list-style-type: none"> 1. Reset and sequence the relay module. 2. If fault reappears, remove power from the device, reapply power, then reset and sequence the relay module. 3. If fault does not repeat on the next cycle, check for electrical noise being copied into the relay module through the external loads or possibly an electrical grounding issue. 4. If the fault persists, replace the relay module. |
| Code 6-3 *Device Specific* | Fault with special OEM input circuits. | <ol style="list-style-type: none"> 1. Check wiring and operation of special OEM inputs. 2. Reset and sequence the relay module. 3. If fault reappears, remove power from the device, reapply power, then reset and sequence the relay module. 4. If the fault does not repeat on the next cycle, check for electrical noise being copied into the relay module through the external loads or possibly an electrical grounding issue. 5. If the fault persists, replace the relay module. |
| Code 6-4 *Accessory Fault* | Unused at this time. | — |
| Code 7-7 *Unused* | Unused at this time. | — |

Automation and Control Solutions

Honeywell International Inc.
1985 Douglas Drive North
Golden Valley, MN 55422
customer.honeywell.com

Honeywell Limited-Honeywell Limitée
35 Dynamic Drive
Scarborough, Ontario M1V 4Z9

