

RM7898A 7800 SERIES Valve Proving Primary Relay Modules

INSTALLATION INSTRUCTIONS

APPLICATION

The RM7898 is a microprocessor-based integrated burner control for automatically fired gas, oil or combination fuel single burner applications. The RM7898 system consist of a relay module, subbase, amplifier, and purge card. Options include Keyboard Display Module (KDM), Personal Computer Interface, Data ControlBus™ Module, remote display mounting, Expanded Annunciator and Combustion System Manager® Software.

Functions provided by the RM7898 include automatic burner sequencing, flame supervision, system status indication, system or self-diagnostics and troubleshooting.

The RM7898 provides unique functions to a standard primary control.

As received, the RM7898 offers the following features:

- Interrupted pilot with 10 second pilot flame establishing period.
 - Main valve operation with 10 second MFEP.
 - Pre-Ignition Interlock (POC) input.
 - Shutter-driven output when appropriate amplifier is selected (R7861A, R7886A, R7852C).
 - Blinking Fault Code Power LED on safety shutdown.
- RM7898A1018 offers early spark shutoff when flame is sensed.

Available features when appropriate terminals are energized:

- Intermittent pilot T8 (Terminal 18).
- Direct spark feature for Valve Proving System (VPS) (Terminal 19).
- Valve Proving System function (Terminal 17).
- See Appendix B for examples of 24 single or dual fuel system combinations with or without using the Valve Proving feature.

Programmable features using the S7800A1142 Keyboard Display Module (KDM) (not included):

- Postpurge time—(up to 66 minutes).
- Valve Prove System features, including:
 - VPS test time
 - When in burner sequence to conduct VPS time (Never, Before, After, Both or Split):

NOTE: The S7800A1142 Series 5 or higher can be programmed for ModBus Communication. (See 65-0288 Spec Sheet.)

At commissioning time, the Valve Proving System may be scheduled to occur at one of five different times:

1. Never—Device default as received; valve proving does not occur.
2. Before—Valve proving after standby and safe start check, prior to ignition trials, concurrent with Pre-Purge.
3. After—Valve proving occurs after the Run state before the device goes to Standby, concurrent with postpurge.
4. Both—Valve proving occurs at both times Before and After noted above.
5. Split—The Main Valve 2 (MV2) (high pressure) seat test is performed at the Before time and the Main Valve 1 (MV1) (low pressure) seat test is performed during the After time.

To perform Valve Proving, it must be commissioned and Demand Input (Terminal 17) must be used.

The following assumptions apply when using the RM7898 Valve Proving testing.

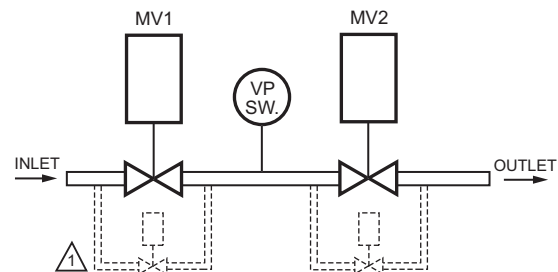

CAUTION: VALVE ENERGIZING TIMING IS BASED ON HONEYWELL VALVE OPENING TIMES OF 13 SECONDS MAXIMUM.
 - FOR VALVES WITH TIMINGS GREATER THAN 13 SECONDS OR THOSE THAT DO NOT OPEN THE ACTIVE VALVE WITHIN THE ENERGIZED TIME, A BYPASS SOLENOID VALVE (1/4", 120 VAC) IS REQUIRED TO OBTAIN THE PROPER TEST PRESSURES.
 - THE BYPASS VALVE WILL BE WIRED IN PARALLEL TO THE VALVE IT IS BYPASSING (TERMINAL 9 FOR MV1 OR TERMINAL 21 FOR MV2).

M24161

Fig. 1. Valve Proving System—simplified diagram.

MV1—Wired to terminal 9. It is located at the most upstream position of the main gas valve train.

VPS—Valve Proving Switch (Rated 1/2 of main valve inlet pressure).

MV2—Wired to terminal 21. It is the main valve located closest to the burner.

The Pre-Ignition Interlock switch or Proof of Closure for Terminal 20 can be installed on MV1, MV2, or as a series connection through both valves.



WARNING

Explosion Hazard
Can cause severe injury, death or property damage.

Be sure to select adequate testing times when the Valve Proving feature is enabled. A shorter time can result in inadequate leak testing of the valves.

This document provides installation and static checkout instructions. Other applicable publications are:

Publication No.	Product
63-2278	Q7700 Network Interface Unit Product Data
65-0084	Q7800A,B 22-Terminal Wiring Subbase Product Data
65-0288	S7800A1142 Keyboard Display Module Product Data
65-0091	S7810A Data ControlBus™ Module Product Data
65-0095	S7820 Remote Reset Module Product Data
65-0097	221729C Dust Cover Installation Instructions
65-0101	S7830 Expanded Annunciator Product Data
65-0102	ZM7850A Combustion System Manager™ Operating Instructions
65-0109	R7824, R7847, R7848, R7849, R7851, R7861, R7886 Flame Amplifiers for the 7800 SERIES Product Data
65-0131	221818A Extension Cable Assembly Product Data
65-0229	7800 SERIES Relay Modules Checkout and Troubleshooting Product Data.
65-0092	QS7800A ControlBus™ Module, Standard
65-0227	QS7800B ControlBus™ Module, Multidrop
65-0249	S7810M ModBus Module

SPECIFICATIONS

Electrical Ratings (See Table 3):

Voltage and Frequency:
 RM7898: 120 Vac (+10/-15%), 50/60 Hz (± 10%).
 Power Dissipation: 10W maximum.
 Maximum Total Connected Load: 2000 VA.

Fusing Total Connected Load: 15A Fast Blow, type SC or equivalent.

Environmental Ratings:

Ambient Temperature:
 Operating: -40°F to 140°F (-40°C to +60°C).
 Storage: -40°F to 150°F (-40°C to +66°C).
 Humidity: 85% relative humidity continuous, noncondensing.
 Vibration: 0.5G environment.

Approvals:

Underwriters Laboratories Inc. Listed: File No. MP268, Guide No. MCCZ.
 Canadian Standards Association Certified: Pending.
 Factory Mutual Approved: Report No. Pending.
 IRI Acceptable.
 Federal Communications Commission: Part 15, Class B, Emissions.

INSTALLATION

When Installing this Product...

1. Read these instructions carefully. Failure to follow them could damage the product or cause a hazardous condition.
2. Check the ratings given in the instructions and marked on the product to make sure the product is suitable for the application.
3. Installer must be a trained, experienced, flame safeguard service technician.
4. After installation is complete, check out the product operation as provided in these instructions.

WARNING

Fire or Explosion Hazard.
Can cause severe injury, death or property damage.
 Follow applicable safety requirements when installing a control on a burner to prevent death or severe injury.

WARNING

Electrical Shock Hazard.
Can cause serious injury, death or equipment damage.

Disconnect power supply before beginning installation. More than one disconnect may be required.

IMPORTANT

1. *Wiring connections for the relay modules are unique; refer to Figs. 4 and 5 or the appropriate Specifications for proper subbase wiring.*
2. *Wiring must comply with all applicable codes, ordinances and regulations.*
3. *Wiring must comply with NEC Class 1 (Line Voltage) wiring.*
4. *Loads connected to the RM7898 must not exceed those listed on the RM7898 label or the Specifications; see Table 3.*
5. *Limits and interlocks must be rated to simultaneously carry and break current to the ignition transformer, pilot valve, and main fuel valve(s).*
6. *All external timers must be listed or component-recognized by authorities who have proper jurisdiction.*
7. *For on-off gas-fired systems, some authorities who have jurisdiction prohibit the wiring of any limit or operating contacts in series between the flame safeguard control and the main fuel valve(s).*
8. *Two flame detectors can be connected in parallel with the exception of Flame Detectors C7015, C7927, C7961 and C7962.*
9. *This equipment generates, uses and can radiate radio frequency energy and, if not installed and used in accordance with the instructions, can cause interference with radio communications. It has been tested and found to comply with the limits for a Class B computing device of Part 15 of FCC rules, which are designed to provide reasonable protection against such interference when operated in a commercial environment. Operation of this equipment in a residential area may cause interference, in which case, the users, at their own expense, may be required to take whatever measures are required to correct this interference.*
10. *This digital apparatus does not exceed the Class B limits for radio noise for digital apparatus set out in the Radio Interference Regulations of the Canadian Department of Communications.*

Location**Humidity**

Install the relay module where the relative humidity never reaches the saturation point. The relay module is designed to operate in a maximum 85% relative humidity continuous, noncondensing, moisture environment. Condensing moisture can cause a safety shutdown.

Vibration

Do not install the relay module where it can be subjected to vibration in excess of 0.5G continuous maximum vibration.

Weather

The relay module is not designed to be weather tight. When installed outdoors, protect the relay module in an approved weather-tight enclosure.

Mounting Wiring Subbase

1. Mount the subbase in any position except horizontally with the bifurcated contacts pointing down. The standard vertical position is recommended. Any other position decreases the maximum ambient temperature rating.
2. Select a location on a wall, burner or electrical panel. The Q7800 can be mounted directly in the control cabinet. Be sure to allow adequate clearance for service, installation, access or removal of the RM7898 Expanded Annunciator, Keyboard Display Module, Flame Amplifier, Flame Amplifier Signal Voltage Probes, run/test switch, electrical signal voltage probes and electrical field connections.
3. For surface mounting, use the back of the subbase as a template to mark the four screw locations. Then drill the pilot holes.
4. Securely mount the subbase using four no. 6 screws (not provided).

Wiring Subbase**⚠ WARNING****Electrical Shock Hazard.**

Can cause severe injury, death or equipment damage.

Disconnect the power supply before beginning installation. More than one disconnect may be required.

The internal block diagram of the RM7898 is shown in Fig. 1.

1. For proper subbase wiring and sequence chart, refer to Fig. 4 and 5.
2. For remote wiring of the Keyboard Display Module, refer to the Specifications for the Keyboard Display Module (65-0288), Network Interface Unit (63-2278), Data ControlBus™ Module (65-0091) or Extension Cable Assembly (65-0131).
3. Disconnect the power supply from the main disconnect before beginning installation to prevent electrical shock and equipment damage. More than one disconnect can be required.
4. All wiring must comply with all applicable electrical codes, ordinances and regulations. Wiring, where required, must comply with NEC, Class 1 (Line Voltage) wiring.
5. For recommended wire size and type, see Table 1.
6. For recommended grounding practices, see Table 2.

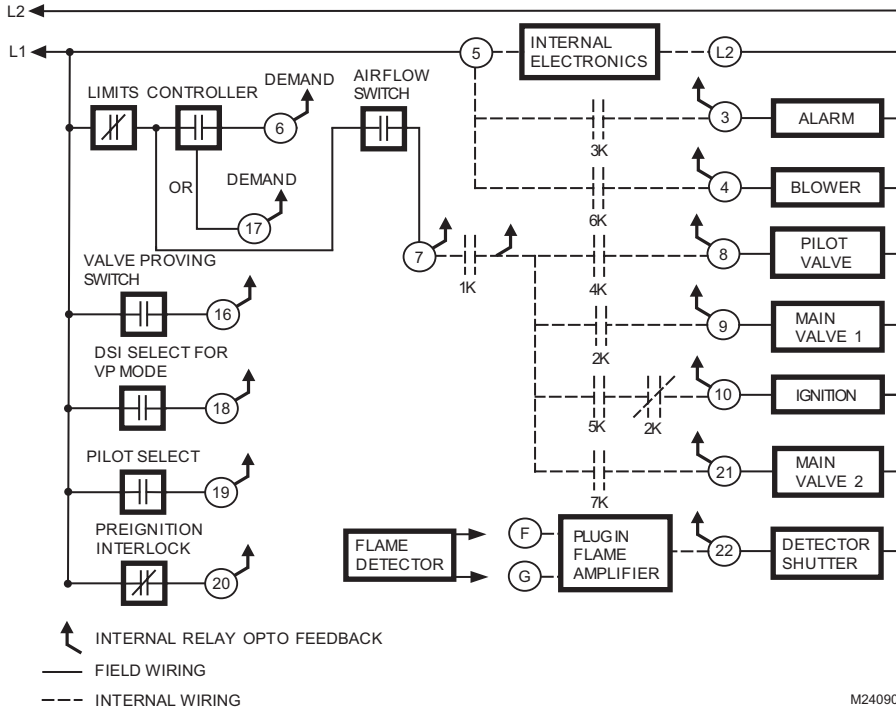

Fig. 2. Internal block diagram of RM7898 (see Figs. 4 and 5 for detailed wiring instructions).

7. Recommended wire routing of leadwires:

- a. Do not run high voltage ignition transformer wires in the same conduit with the flame detector, Data ControlBus™ Module, or Remote Reset Module wiring.
- b. Do not route flame detector, Data ControlBus™ Module, or Remote Reset Module leadwires in conduit with line voltage circuits.
- c. Enclose flame detector leadwires without armor cable in metal cable or conduit.

d. Follow directions in flame detector, Data ControlBus™ Module, or Remote Reset Module Instructions.

- 8.** The KDM is powered from a low voltage, energy limited source. It can be mounted outside of a control panel if it is protected from mechanical damage.

NOTE: A 13 Vdc power supply must be used any time more than one KDM is used.

BEFORE

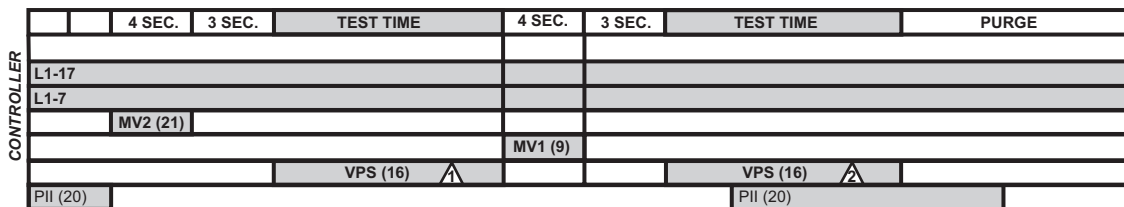

AFTER

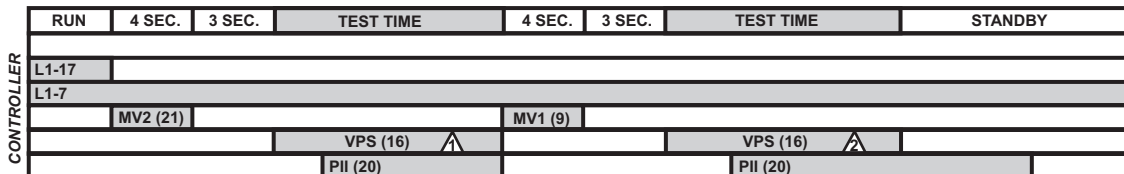

SPLIT

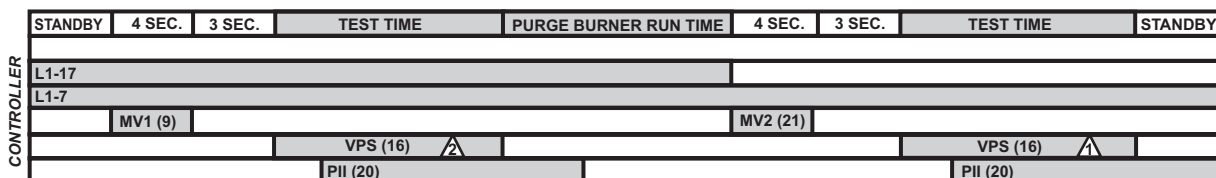

- ▲ LOCKOUT IF ON, M1 LEAKING (LOW PRESSURE TEST).
- ▲ LOCKOUT IF OFF, MV2 LEAKING (HIGH PRESSURE TEST).

M24189

Fig. 3. RM7898 Relay Module operation, Valve Proving Test options.

Table 1. Recommended Wire Sizes and Part Numbers.

Application	Recommended Wire Size	Recommended Part Numbers
Line voltage terminals.	14, 16 or 18 AWG copper conductor, 600 volt insulation, moisture-resistant wire.	TTW60C, THW75C, THHN90C.
Keyboard Display Module	22 AWG two-wire twisted pair with ground, or five-wire.	Belden 8723 shielded cable or equivalent.
Data ControlBus™ Module ^a	22 AWG two-wire twisted pair with ground, or five-wire.	Belden 8723 shielded cable or equivalent.
Remote Reset Module	22 AWG two-wire twisted pair, insulated for low voltage.	—
Communications Interface ControlBus™ Module ^a	22 AWG two-wire twisted pair with ground.	Belden 8723 shielded cable or equivalent.
13 Vdc full-wave rectified transformer power input.	18 AWG wire insulated for voltages and temperatures for given application.	TTW60C, THW75C, THHN90C.

^a The KDM, Data ControlBus™ Module (for remote mounting or communications) or Communication Interface ControlBus™ Module must be wired in daisy chain configuration, 1(a)-1(a), 2(b)-2(b), 3(c)-3(c). The order of interconnection of all the devices listed above is not important. Be aware that modules on the closest and farthest end of the daisy chain configuration string require a 120 ohm (1/4 watt minimum) resistor termination across terminals 1 and 2 of the electrical connectors for connections over 100 feet (31 meters).

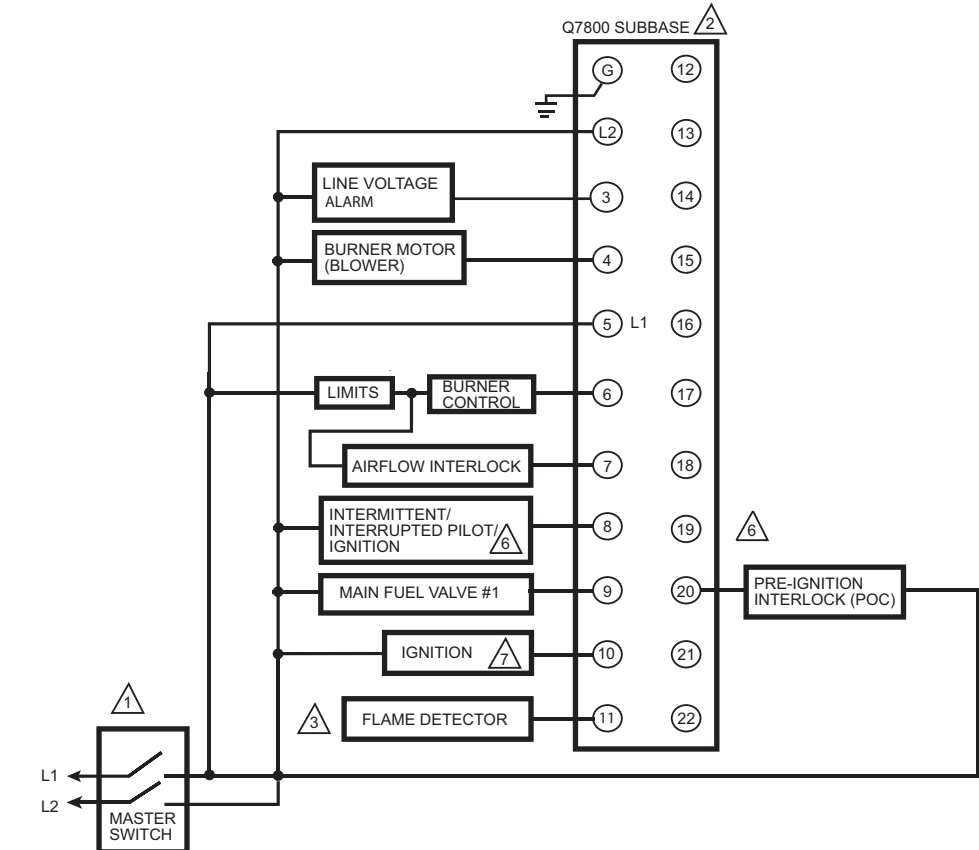

	INITIATE (INITIAL POWERUP ONLY)	STANDBY	00 TIMED PREPURGE	00 (4 SEC. IF 10 PFEP 10 SEC. JR1 CLIPPED)	MFEP	20 RUN	00 POSTPURGE	STANDBY
LED DISPLAY	● POWER ○ ○ ○ ○	● POWER ○ ○ ○ ○	● POWER ○ PILOT ○ FLAME ○ MAIN ○ ALARM	● POWER ● PILOT ● FLAME ○ MAIN ○ ALARM	● POWER ● PILOT ● FLAME ● MAIN ○ ALARM	● POWER ● PILOT ● FLAME ● MAIN ○ ALARM	○ ○ ○ ○ ○	○ ○ ○ ○ ○
BURNER			BURNER/BLOWER MOTOR (4)					
			(10) IGN.					
						INTERMITTENT PILOT (8)		
					MAIN VALVE (9)			
OPERATING CONTROLS AND INTERLOCKS			LIMITS AND BURNER CONTROLLER CLOSED (L1) TO (6)					
			RUNNING INTERLOCKS CLOSED (6) TO (7)					
			PREIGNITION INTERLOCK CLOSED (5) TO (20)				PII	
FLAME SIGNAL			SAFE START CHECK		FLAME PROVING			SSC

- 1 120V, 50/60 HZ POWER SUPPLY. PROVIDE DISCONNECT MEANS AND OVERLOAD PROTECTION (15 AMP TYPE SC FUSE OR EQUIVALENT FAST BLOW FUSE) AS REQUIRED.
- 2 DO NOT CONNECT ANY WIRES TO UNUSED TERMINALS.
- 3 SEE FLAME DETECTOR SPECIFICATIONS FOR CORRECT DETECTOR WIRING.
- 4 PROGRAMMED ON SETUP USING S7800A1142 DISPLAY.
- 5 PURGE TIME DEPENDS ON WHICH ST7800 IS INSTALLED.
- 6 PROVIDE LINE VOLTAGE INPUT TO TERMINAL 19 FOR INTERMITTENT PILOT OPERATION.
- 7 RM7898A1018 PROVIDES FOR EARLY SPARK TERMINATION (IGNITION SHUTS OFF WHEN FLAME IS SENSED), PFEP TIMING WILL COMPLETE BEFORE GOING TO RUN.

M24137

Fig. 4. Wiring subbase and sequence chart for RM7898 without Valve Proving.

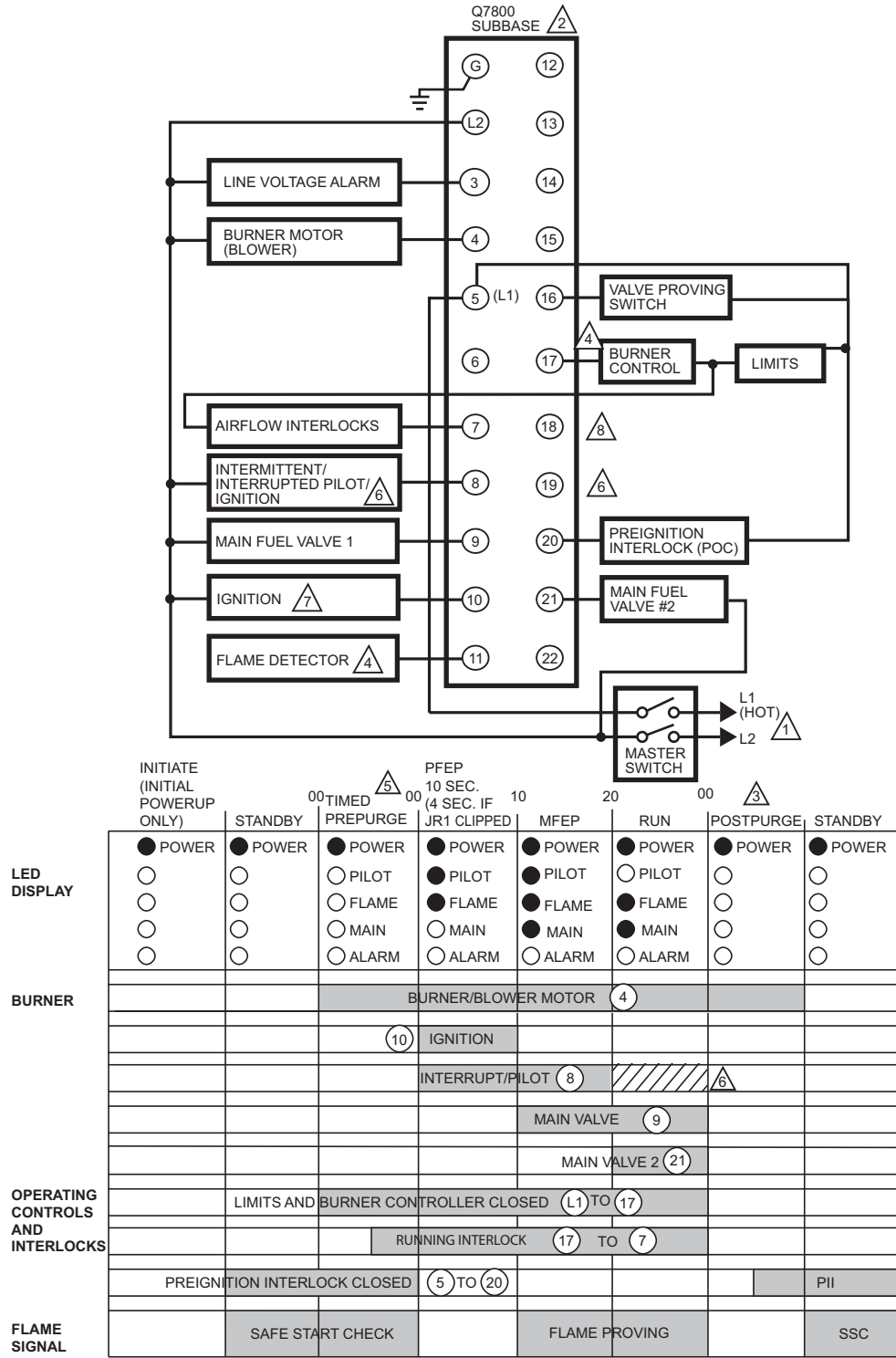

1 120 VAC, 50/60 HZ POWER SUPPLY. PROVIDE DISCONNECT MEANS AND OVERLOAD PROTECTION AS REQUIRED.

2 DO NOT CONNECT ANY WIRES TO UNUSED TERMINALS.

3 PROGRAMMABLE POST PURGE TIMING USING S7800A1142 KDM.

4 SEE FLAME DETECTOR SPECIFICATIONS FOR CORRECT WIRING.

5 PURGE TIME DEPENDS ON WHICH ST7800 IS INSTALLED.

6 PROVIDE LINE VOLTAGE INPUT TO TERMINAL 19 FOR INTERMITTENT PILOT OPERATION.

7 RM7898A1018 PROVIDES FOR EARLY SPARK TERMINATION (IGNITION SHUTS OFF WHEN FLAME IS SENSED). PFEP TIMING WILL COMPLETE BEFORE GOING TO MAIN FLAME ESTABLISHING PERIOD.

8 PROVIDE LINE VOLTAGE INPUT TO TERMINAL 18 FOR GAS FIRED DIRECT SPARK IGNITION APPLICATIONS.

M24188

Fig. 5. Wiring subbase and sequence chart for RM7898 with Valve Proving.

Table 2. Recommended Grounding Practices.

Ground Type	Recommended Practice
Earth ground (subbase and relay module).	<ol style="list-style-type: none"> 1. Use to provide a connection between the subbase and the control panel of the equipment. Earth ground must be capable of conducting enough current to blow the 15A, type SC, fast blow fuse (or breaker) in the event of an internal short circuit. 2. Use wide straps or brackets to provide minimum length, maximum surface area ground conductors. If a leadwire is required, use 14 AWG copper wire. 3. Make sure that mechanically tightened joints along the ground path are free of nonconductive coatings and protected against corrosion on mating surfaces.
Signal ground (Keyboard Display Module, Data ControlBus™ Module, Communications Interface ControlBus™ Module).	Use the shield of the signal wire to ground the device to the signal ground terminal 3(c) of each device. Connect the shield at both ends of the daisy chain to earth ground.

9. Maximum wire lengths:
 - a. RM7898 leadwires: The maximum leadwire length is 300 feet to terminal inputs (Control, Running/ Lockout Interlock).
 - b. Flame Detector leadwires: The maximum flame sensor leadwire length is limited by the flame signal strength.
 - c. Remote Reset leadwires: The maximum length of wire is 1000 feet (305 meters) to a Remote Reset push button.
 - d. Data ControlBus™ Module: The maximum Data ControlBus™ Module cable length depends on the number of system modules connected, the noise conditions and the cable used. The maximum length of all Data ControlBus™ Module interconnecting wire is 4000 feet (1219 meters).
10. Be sure loads do not exceed the terminal ratings. Refer to the label on the RM7898 or to the terminal ratings in Table 3.

Final Wiring Check

1. Check the power supply circuit. The voltage and frequency tolerance must match those of the RM7898. A separate power supply circuit can be required for the RM7898. Add the required disconnect means and overload protection.
2. Check all wiring circuits and complete Static Checkout in Table 6 before installing the RM7898 on the subbase.
3. Install all electrical connectors.
4. Restore power to the panel.

Table 3. Terminal Ratings.

Terminal Number	Description	Ratings
		RM7898
G	Flame Sensor Ground	—
Earth G	Earth Ground ^a	—
L2(N)	Line Voltage Common	—
3	Alarm	120 Vac, 1A pilot duty.
4	Burner Motor	120 Vac, 9.8A AFL, 58.8 ALR (inrush).
5	Line Voltage Supply (L1)	120 Vac (+10/-15%), 50 or 60 Hz (±10%). ^b
6 or 17	Burner Controller and Limits	120 Vac, 1 mA.
7	Lockout Interlock	120 Vac, 8A run, 43A inrush.
8	Pilot Valve/Ignition	120 Vac ^c
9	Main Fuel Valve	120 Vac ^c
10	Ignition	120 Vac ^c
F(11)	Flame Sensor	60 to 220 Vac, current limited.
12 to 15	— Not Used	—
16	Valve Proven Pressure Switch Impact	120Vac, 1mA.
17	Valve Proven Test Enable	120 Vac 1mA.
18	Terminal 8 Intermittent Pilot Enable	120 Vac 1mA.
19	DSI Enable	120 Vac 1mA.
20	Pre-Ignition Interlock	120 Vac, 1 mA.
21	2nd Stage Main Valve	120 Vac ^c
22	Shutter	120 Vac, 0.5A

^a See Table 2.

^b 2000 VA maximum load connected to RM7898 Assembly.

^c See Tables 4 and 5.

Table 4. Combinations for Terminals 8, 9, 10 and 21.

Combination Number	Pilot Fuel 8	Main 9	Ignition 10	Main Valve 2 (21)
1	C	F	No Load	C
2	B	F	No Load	B
3	F	F	A	F
4	F	F	A	F
5	F	F	A	F
6	D	F	A	D
7	D	D	A	D
8	D	D	A	D
9	D	No Load	A	D

Table 5. Composition of each Combination.

A	B ^a	C	D	F
4.5A ignition	50 VA Pilot Duty ^a plus 4.5A ignition.	180 VA Ignition plus motor valves with: 660 VA inrush, 360 VA open, 240 VA hold.	2A Pilot Duty ^a	65 VA Pilot Duty ^a plus motor valves with: 3850 VA inrush, 700 VA open, 250 VA hold.

^a Pilot Duty refers to a solenoid valve.

STATIC CHECKOUT

After checking all wiring, perform this checkout before installing the RM7898 on the subbase. These tests verify the Q7800 Wiring Subbase is wired correctly, and the external controllers, limits, interlocks, actuators, valves, transformers, motors and other devices are operating properly.

WARNING

Fire or Explosion Hazard.
Can cause property damage, severe injury or death.
 Close all manual fuel shutoff valve(s) before starting these tests.

Use extreme care while testing the system. Line voltage is present on most terminal connections when power is on.

Ensure proper selection of configuration jumpers before starting the burner operation.

CAUTION

Electrical Hazard.
Can cause equipment damage or failure.
 Do not perform a dielectric test with the relay module installed. Internal surge protectors can break down, allowing relay module to fail the dielectric test and destroy the internal lightning and high current protection.

1. Open the master switch before installing or removing a jumper on the subbase.
2. Before continuing to the next test, be sure to remove the test jumper(s) used in the previous test.

3. Replace all limits and interlocks that are not operating properly. Do not bypass limits and interlocks.

Equipment Recommended

1. Voltmeter (1M ohm/volt minimum sensitivity) set on the 0 to 300 Vac scale.
2. Two jumper wires, no. 14 wire, insulated, 12 in. (304.8 mm) long with insulated alligator clips at both ends.

General Instructions

1. Perform all applicable tests listed in Static Checkout, Table 6, in the order listed.
2. Make sure all manual fuel shutoff valve(s) are closed.
3. For each test, open the master switch and install the jumper wire(s) between the subbase wiring terminals listed in the Test Jumpers column.
4. Close the master switch before observing operation.
5. Read the voltage between the subbase wiring terminals listed in the Voltmeter column.
6. If there is no voltage or the operation is abnormal, check the circuits and external devices as described in the last column.
7. Check all wiring for correct connections, tight terminal screws, correct wire, and proper wiring techniques. Replace all damaged or incorrectly sized wires.
8. Replace faulty controllers, limits, interlocks, actuators, valves, transformers, motors and other devices, as required.
9. Make sure normal operation is obtained for each required test before continuing the checkout.
10. After completing each test, be sure to open the master power switch and remove the test jumper(s) before proceeding to the next test.

Table 6. Static Checkout.

Test Number	Relay Module Model	Test Jumpers	Voltmeter	Normal Operation	If Operation is Abnormal, Check Items Listed Below
1	All	None	5-L2	Line voltage at terminal 5.	1. Master switch. 2. Power connected to master switch. 3. Overload protection (fuse, circuit breaker, etc.) has not opened power line.
2	All	None	6-L2 or 17-L2	Line voltage at terminal 6 or 17. For Valve Proving.	1. Limits. 2. Burner controller.
3	All	4-5	7-L2	1. Burner motor (fan or blower) starts. 2. Line voltage at terminal 7 within 10 seconds.	1. Burner motor circuit. a. Manual switch of burner motor. b. Burner motor power supply, overload protection and starter. c. Burner motor.
4	All		20-L2	Line voltage at Terminal 20	Pre-Ignition Interlocks.
5	All	5-10*	—	1. Ignition spark (if ignition transformer is connected to terminal 10).	1. Watch for spark or listen for buzz. a. Ignition electrodes are clean. b. Ignition transformer is okay.
6	All	5-8*	—	1. Ignition spark (if ignition transformer is connected to terminal 8). 2. Automatic pilot valve opens (if connected to terminal 8). NOTE: Refer to wiring diagram of system being tested.	1. Watch for spark or listen for buzz. 2. Listen for click or feel head of valve for activation. a. Actuator if used. b. Pilot valve.
7	All	5-9*	—	Automatic fuel valve(s) open(s). If using direct spark ignition, check first stage fuel valve(s) instead of pilot valve.	Same as test 6. If using direct spark ignition, check first stage fuel valve(s) instead of pilot valve.
8	All	5-21*	—	Automatic second stage main fuel valve(s) open(s).	1. Listen for and observe operation of second stage main fuel valve(s) and actuator(s). 2. Valve(s) and actuator(s).
9	All	5-3	—	Alarm (if used) turns on.	1. Alarm.
Final	All	 CAUTION Equipment Damage Hazard. Can cause equipment damage. After completing these tests, open master switch and remove all test jumpers from subbase terminals. Also remove bypass jumpers, if used, from low fuel pressure limits.			

*Replace jumper wire with ammeter and verify loads to component ratings.

VALVE PROVING SYSTEM

The Valve Proving System feature provides a systematic way of testing the valve seat integrity to assure the valves are in the closed state whenever the sequence of operation requires them to be closed. It is designed to detect a leak greater than 0.1% of the burner input capacity. For example, a 10 million Btu/hr natural gas-fueled burner would have a fuel input capacity of approximately 1,000 ft³/hr. A leak rate greater than 0.1% of 1,000 ft³/hr or 1 ft³/hr in either valve will be detected with the Valve Proving System. Smaller leaks will not be detected.

At commissioning time, the Valve Proving System may be scheduled to occur at one of five different times: Never, Before, After, Both, and Split.

Never—Device default as received: in this case Valve Proving does not occur.

Before—Valve Proving occurs concurrent with Pre-Purge.

After—Valve Proving occurs after the Run state before the internal Safety Relay dropout state and concurrent with Post Purge (if configured).

Both—Valve Proving occurs at both times Before and After noted above.

Split—The downstream seat (high pressure) test is performed at the Before time and the upstream seat (low pressure) test is performed during the After time.

The Valve Proving items programmed are:

1. Specify Valve Proving and when to perform it.
2. Specify the time duration of the test (calculated from Appendix A).

Typical Valve Proving System Function

Valve Proving consists of monitoring the pressure in the space between two shutoff valves, MV1 (upstream) and MV2 (downstream). The Valve Proving function, identified by letters A through F, operates as follows:

The tolerance on all Valve Proving timing values is $\pm 10\%$.

The following are steps performed during Valve Proving tests. This section is for background information and does not define the exact behavioral requirements.

As the RM7898 starts Purging:

- a. MV2 is commanded to be open while MV1 remains closed; to depressurize the space. After 4 seconds, MV2 is commanded closed again.
- b. This is followed by a three second delay during which the Valve Proving pressure switch (VPS) is ignored.
- c. Thereafter, the VPS is monitored for the duration of the Valve Proving test time and, if it turns on, then a lock-out occurs. (Because the gas pressure has increased due to a leaky upstream valve.) (Low pressure test)

- d. MV1 is commanded to be open while MV2 remains closed, to pressurize the space. After 4 seconds, MV1 is commanded closed again.
- e. This is followed by a three second delay, during which the Valve Proving pressure switch (VPS) is ignored.
- f. Thereafter, the VPS is monitored for the duration of the Valve Proving test time and, if it turns off, then a lockout occurs. (Because the gas pressure has decreased due to a leaky downstream valve.) (High pressure test.)

Pressure Switches for Valve Proving System

The Valve Proving System requires a pressure switch to be installed to monitor the pressure in the internal space between the two shutoff valves. Recommended pressure switches are the following Honeywell non-manual reset models:

Table 7. Honeywell Pressure Switch Selection for Valve Proving System.

1	2	3	4	5	6
Model Number	Operating Pressure Range	Maximum Differential (Additive)	Maximum Continuous Rated Pressure (psi)	Switch Action at Setpoint	Mounting Type
C6097A1004	0.4 to 5 in. wc	0.24 in. wc	2.9	Breaks N.O. to C connection on pressure fall.	1/4 in. NPT
C6097A1053	3 to 21 in. wc	0.48 in. wc	5.0		Flange
C6097A1061					1/4 in. NPT
C6097A1079	12 to 60 in. wc	2.4 in. wc	9.3		Flange
C6097A1087					1/4 in. NPT
C6097A1129	1.5 to 7 psi	0.3 psi	2.9		Flange
C6097A1137					1/4 in. NPT
C6097A1210	0.4 to 4 in. wc	0.24 in. wc			

Pressure Switch Selection

1. Determine the maximum operating inlet pressure for the upstream valve; for example, 5.0 psi (140 in. wc).
2. Divide the inlet pressure by two (2.5 psi [70 in. wc], for example).
3. From column 2 in Table 7 find the operating range upper limit that is closest to but greater than the inlet pressure divided by two. In the example given, the possible selections from column 1 are the C6097A1129 and C6097A1137 with an operating range upper limit of 7 psi. (The C6097A1079 and C6097A1087 with an upper limit of 60 in. wc are close, but 60 in. wc is less than the 70 in. wc minimum, so the next higher range must be selected.)

4. From column 6, select the preferred mounting type, 1/4 in. NPT or Flange. For example, if a flange mount is required, the pressure switch choice from column 1 would be the C6097A1137.

Pressure Switch Installation and Adjustment

1. Refer to the instructions for the C6097A Pressure Switch, form number 65-0237.
2. Install the C6097A Pressure Switch according to the instructions.
3. Adjust the setpoint to 50% of the maximum operating inlet pressure for the upstream valve.
4. Complete the operation and checkout procedures in the instructions.

Setup of Valve Proving and Post Purge Functions

Prior to setup of the Valve Proving and Post Purge functions, follow the procedures in the appendix to complete the worksheet and obtain the Valve Proving Test Time.

An S7800A1142 Keyboard Display Module (KDM) is required for this setup and the RM7898 must have the Valve Proving function.

When the RM7898 is installed and powered, “**STANDBY**” will be shown on the first line of the display.

1. Scroll down until the “**Setup**” is displayed in the second line. (Setup is only available when the control is in Standby or Lockout state.)

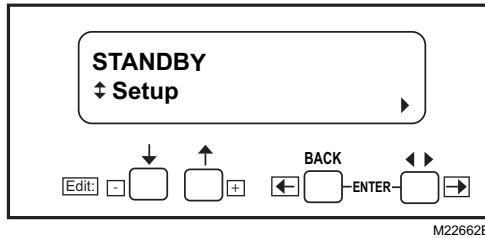

Fig. 6. STANDBY/Setup screen.

2. Enter the Setup submenu by pressing the far right key on the display. Note that the second line now reads “**BC Password**”.

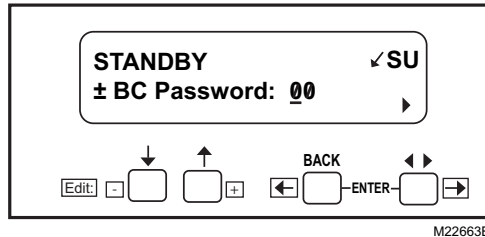

Fig. 7. Password screen.

3. Use the +/- buttons to enter the first number, 7.
4. Use the far right key to shift over one space.
5. Use the +/- buttons to enter the second number, 8.
6. Press Enter (left/right arrow simultaneously).

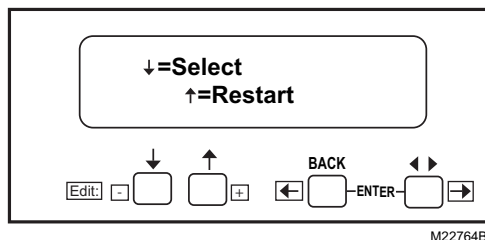

Fig. 8. Select/Restart screen.

7. To get to the next screen, press the down arrow. “**Getting Data**” will be displayed, then the following screen.

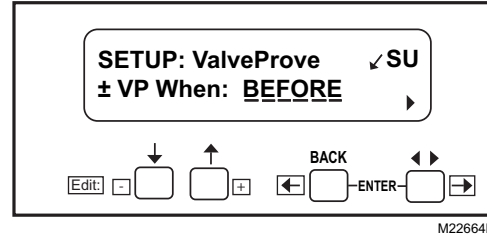

Fig. 9. SETUP: Valve Prove screen.

NOTE: This screen sets up when to do the Valve Proving test.

8. Use the up/down arrows to select from Never, Before, After, Both, or Split, then press ENTER.

NOTE: Use Never (as shipped) on initial startup so gas line purging and System Checkout can be performed. Then come back to set final operation configuration. Be sure to conduct final VPS System checkout when Setup is complete.

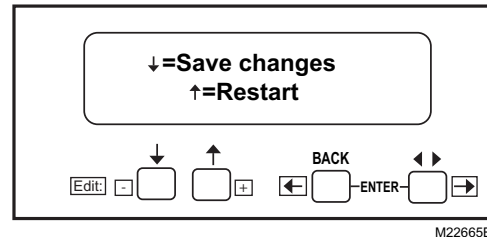

Fig. 10. Save Changes screen.

9. Use the down arrow to save changes. After pressing the down arrow, “**Getting Data**” is displayed.

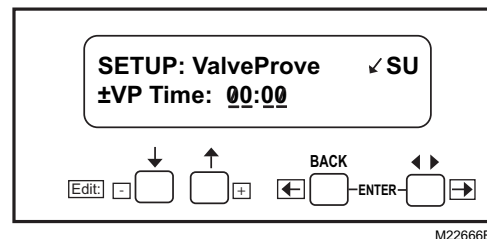

Fig. 11. Valve Prove time screen.

This screen sets up how long the RM7898 will conduct the Valve Proving test for a given time. VP Time: 00:00 is shown.

10. Enter the appropriate Valve Proving test time from the worksheet in the appendix. Use the + button to increase and - button to decrease time. Time changes:

- a. 0 to 60 seconds in 1-second intervals.
- b. 60 to 600 seconds in 10-second intervals.
- c. 10 to 60 minutes in 1-minute intervals.

Press ENTER when correct time is displayed.

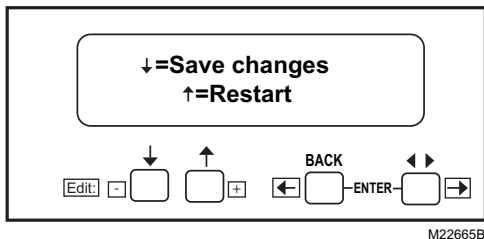

Fig. 12. Save Changes screen.

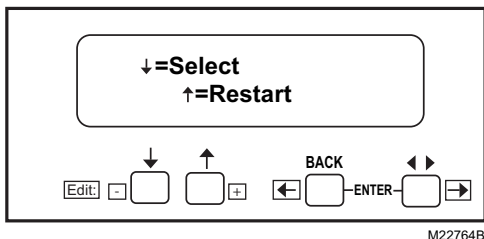

Fig. 13. Select/Restart screen.

11. Press down arrow to select.
12. "Getting Data" will be momentarily displayed, followed by the screen shown in Fig.- 13.

Install Postpurge

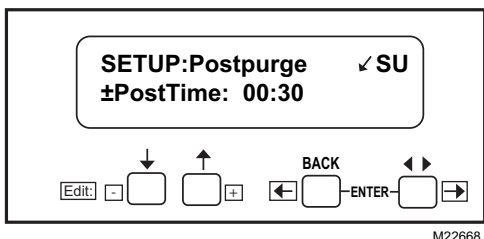

Fig. 14. Setting Post Purge time.

This screen allows for setting up the Postpurge for the RM7898. This will be the time that the Combustion Fan (terminal 5) will remain energized after the STOP button is pushed.

13. Use the +/- buttons to adjust the postpurge time. Time changes:
 - a. 0 to 60 seconds in 1 second intervals.
 - b. 60 to 600 seconds in 10 second intervals.
 - c. 10 to 60 minutes in 1 minute intervals.
14. Press ENTER (Left/Right arrow keys simultaneously) when the correct postpurge time is displayed.

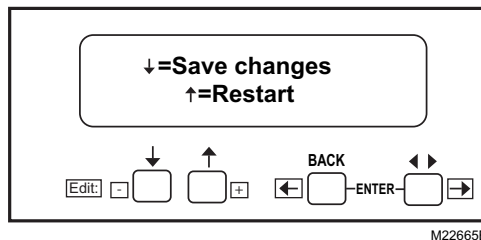

Fig. 15. Save Changes screen.

15. Use the down arrow to save changes. "Getting Data" is displayed momentarily. The following steps are to confirm your selections.

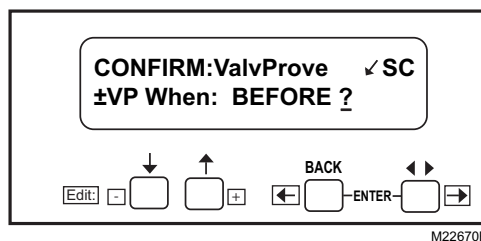

Fig. 16. Confirmation Acknowledgement screen. (The Valve Proving test location is shown.)

16. Press ENTER.

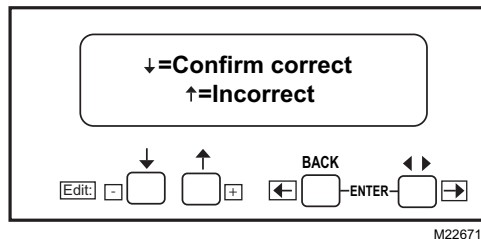

Fig. 17. Confirmation Correct screen.

17. Use the down arrow to confirm correct.

NOTE: Using the up arrow during this step will take you back to the beginning of the setup routine.

"Getting Data" will be displayed.

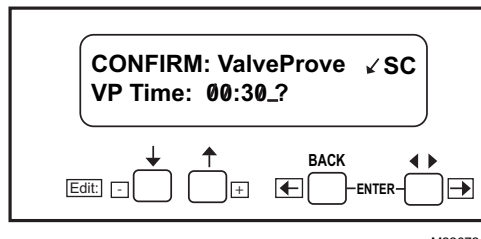

Fig. 18. Confirm screen.

18. Press Enter.

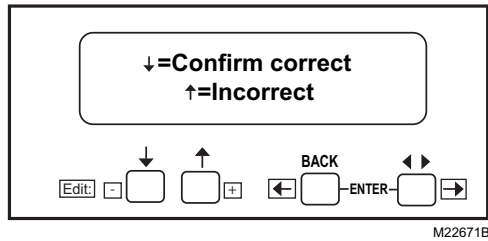

Fig. 19. Confirm Correct screen.

19. Use the down arrow to confirm correct. "Getting Data" will be displayed.

The following steps are used to confirm your selection.

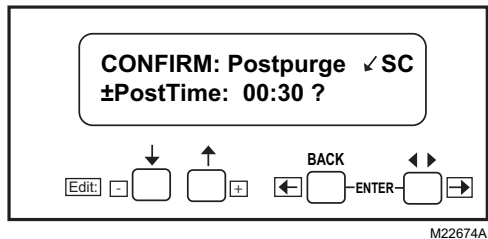

Fig. 20. Confirm Postpurge time.

20. Press Enter.

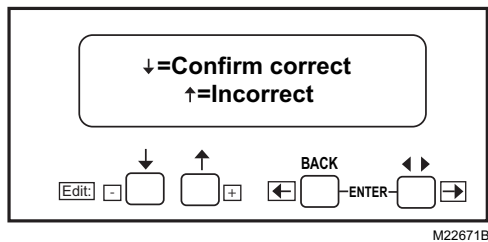

Fig. 21. Confirm correct/incorrect screen.

21. Press Enter.

22. Press the down arrow to confirm the correct postpurge time. "Getting Data" will be displayed until the screen in Fig. 20 appears.

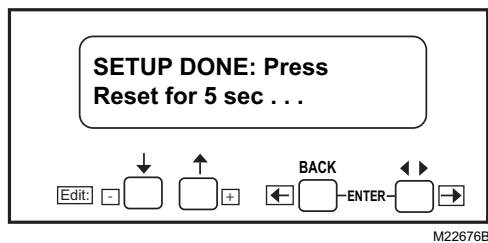

Fig. 22. Setup Done screen.

23. Press and hold the relay module's RESET button for five seconds to program the Valve Proving setup into the relay module.

The Release Reset screen will appear on the KDM.

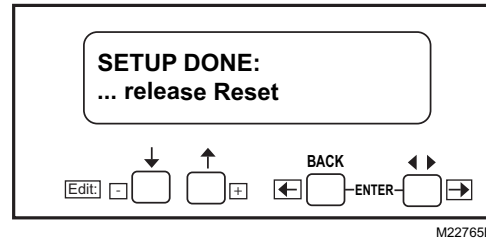

Fig. 23. Release Reset screen.

Future changes to the Valve Proving and PostPurge features are still possible. With the relay module in Standby, scroll to the Setup line and enter the password to change the settings.

Once the system is in operation, the settings of the Valve Proving and Postpurge can be viewed in Diagnostics, using your S7800 Keyboard Module (KDM).

Select Mounting RM7898 Relay Module

1. Mount the RM7898 vertically on the Q7800 Subbase, or mount horizontally with the knife blade terminals pointing down. (For mounting on the Q7800A, mount the RM7898 in an electrical enclosure.)
2. When mounting in an electrical enclosure, provide adequate clearance for service, installation and removal of the RM7898, KDM, flame amplifier, flame amplifier signal voltage probes, electrical signal voltage probes, and electrical connections.
 - a. Allow an additional 2 in. (51 mm) below the RM7898 for the flame amplifier mounting.
 - b. Allow an optional 3 in. (76 mm) minimum to both sides of the RM7898 for electrical signal voltage probes.
3. Make sure no subbase wiring is projecting beyond the terminal blocks. Tuck in wiring against the back of the subbase so it does not interfere with the knife blade terminals or bifurcated contacts.

IMPORTANT

Install the RM7898 with a plug-in motion rather than a hinge action.

4. Mount the RM7898 by aligning the four L-shaped corner guides and knife blade terminals with the bifurcated contacts on the wiring subbase and securely tightening the two screws without deforming the plastic.

Mounting Other System Components (Fig. 24)

Mount other required and optional system components by referring to Fig. 24 and the instructions provided with each component.

PRINCIPAL TECHNICAL FEATURES

The RM7898 provides all customary flame safeguard functions as well as significant advancements in safety, annunciation, and system diagnostics.

Safety Shutdown (Lockout) Occurs if:

1. INITIATE PERIOD
 - a. Purge card is not installed or removed.
 - b. Purge card is bad.
 - c. Configuration jumpers have been changed (after 200 hours)—Fault Code 110.
 - d. AC line power errors occurred, see Operation.
 - e. Four minute INITIATE period has been exceeded.
2. STANDBY PERIOD
 - a. Airflow lockout feature is enabled and the airflow switch does not close after ten seconds or within the specified purge card timing.
 - b. Flame signal is detected after 240 seconds.
 - c. Ignition/pilot valve terminal is energized.
 - d. Main valve 1 or 2 terminal is energized.
 - e. Internal system fault occurred.
 - f. Purge card is removed.
 - g. Purge card is bad.
 - h. Pre-Ignition Interlock open.
3. PREPURGE PERIOD
 - a. Airflow lockout feature is enabled and the airflow switch opens.
 - b. Ignition/pilot valve terminal is energized.
 - c. Main valve 1 or 2 terminal is energized.
 - d. Internal system fault occurred.
 - e. Purge card is removed.
 - f. Purge card is bad.
 - g. Flame signal is detected for 30 seconds.
 - h. Pre-Ignition Interlocks open during standby.
 - i. VPS test failure (if Before, Both, or Split are selected).
 - j. Both T6 and T17 demands energized.
 - k. T17 energized but Valve Proving is not set up.
4. PILOT FLAME ESTABLISHING PERIOD (PFEP).
 - a. Airflow lockout feature is enabled and the airflow switch opens.
 - b. No flame signal at end of PFEP.
 - c. Ignition/pilot valve/intermittent pilot valve terminal is not energized.
 - d. Main valve terminal is energized (unless DSI Select Mode enabled).
 - e. Valve terminal 21 is not on.
 - f. Internal system fault occurred.
 - g. Purge card is removed.
 - h. Purge card is bad.
5. MAIN FLAME ESTABLISHING PERIOD (MFEP)
 - a. Airflow lockout feature is enabled and the airflow switch opens.
 - b. Ignition terminal is energized.
 - c. Ignition/pilot valve terminal is not energized.
 - d. Main valve terminal(s) are not energized.
 - e. Main valve 2 terminal is not energized.
 - f. Loss of flame signal.
 - g. Internal system fault occurred.
 - h. Purge card is removed.
 - i. Purge card is bad.
6. RUN PERIOD
 - a. No flame present (JR2 removed).
 - b. Airflow lockout feature is enabled and the airflow switch opens.
 - c. Interrupted pilot valve terminal is energized.
 - d. Main valve terminal is not energized.
 - e. Internal system fault occurred.
 - f. Purge card is removed.
 - g. Purge card is bad.
 - h. Ignition terminal is energized.

7. POST-PURGE

- a. Pre-Ignition Interlock does not close in 5 seconds.
- b. Ignition/Pilot Valve terminal is energized.
- c. Main Valve(s) terminal is energized.
- d. Internal System Fault.
- e. Purge Card is removed.
- f. Purge Card is bad.
- g. VPS Test failure (if Both, Split or After is selected).

OPERATION

Sequence of Operation

The RM7898 has the operating sequences listed below; see Fig. 4 and 5. The RM7898 LED provide positive visual indication of the program sequence: POWER, PILOT, FLAME, MAIN and ALARM.

Initiate

The RM7898 Relay Module enters the INITIATE sequence when the relay module is powered. The RM7898 can also enter the INITIATE sequence if the relay module verifies voltage fluctuations of +10/-15% or frequency fluctuations of $\pm 10\%$ during any part of the operating sequence. The INITIATE sequence lasts for ten seconds unless the voltage or frequency tolerances are not met. When not met, a hold condition is initiated and displayed on the optional KDM for at least five seconds; when met, the INITIATE sequence restarts. If the condition is not corrected and the hold condition exists for four minutes, the RM7898 locks out. Causes for hold conditions in the INITIATE sequence:

1. AC line dropout detection.
2. AC line noise that can prevent a sufficient reading of the line voltage inputs.
3. Low line voltage brownouts.

The INITIATE sequence also delays the burner motor starter from being energized and de-energized from an intermittent AC line input or control input.

Standby

The RM7898 is ready to start an operating sequence when the operating control input determines a call for heat is present. The burner switch, limits, operating limit control and all microcomputer-monitored circuits must be in the correct state for the relay module to continue into the PREPURGE sequence. (Terminal 17 input initiates the RM7898 VPS feature.)

Normal Start-Up Pre-Purge

The RM7898 Relay Module provides PREPURGE timing, selectable with ST7800 Purge Timer cards, from two seconds to thirty minutes with power applied and the operating control indicating a call for heat.

1. The Airflow Interlock, burner switch, Run/Test switch and all microcomputer-monitored circuits must also be in the correct operating state.
2. The motor output, terminal 4, is powered to start the PREPURGE sequence.
3. The Airflow Interlock input closes ten seconds into PREPURGE or within the specified purge card timing; otherwise, a recycle to the beginning of PREPURGE or lockout occurs, depending on how the Airflow Switch selectable jumper (JR3) is configured.
4. Valve Proving test occurs concurrent with Purge if feature Before, Both, or Split are selected.

Ignition Trials

1. Pilot Flame Establishing Period (PFEP):
 - a. When the PFEP begins:
 - (1) The pilot valve and ignition transformer, terminals 8 and 10, are energized. The RM7898 has an interrupted pilot valve, terminal 8; intermittent if terminal 19 is powered. (RM7898A1018 shuts the ignition off when flame is sensed.)
 - (2) Flame must be proven by the end of the ten second PFEP (four seconds if Configuration Jumper JR1 is clipped). If a flame is not proven by the end of PFEP, a safety shutdown occurs.
 - (3) the Pre-Ignition Interlock is ignored throughout the Trial for Ignition State.
2. Main Flame Establishing Period (MFEP):
 - a. After PFEP, and with the presence of flame, the main fuel valve, terminal 9 (and 21 for Valve Proving operation) is powered.
 - b. The RM7898 has a ten second MFEP. The interrupted pilot valve, terminal 8, is de-energized (with terminal 19 powered, terminal 8 will remain on intermittent pilot throughout the run period).
 - (1) If flameout occurs, the RM7898 recycles to the beginning of Purge. In VP mode, valve proving testing will not repeat.
 - (2) If Configuration Resistor (JR2) is clipped, the RM7898 will lockout and Postpurge if programmed. Valve Proving testing will be conducted if Both, Split, or After option is selected.
3. Direct Spark Ignition with Valve Proving feature: Demand Input is terminal 17 and Enable (120V power) connected to terminal 18.
 - a. When this main flame establishing period begins:
 - (1) Ignition, Main Valve 1, and Main Valve 2 terminals, 9, 10, and 21, are turned on simultaneously.
 - (2) Flame must be proven at the end of the 4-second main flame establishing time. Ignition terminal 10 is shut off and system is in Run. The

RM7898A1018 will shut off the ignition when flame is sensed, but the establishing period continues.

- (3) If flame is not proven by the end of this main flame establishing period, safety shutdown occurs.
- (4) The Pre-Ignition Interlock is ignored throughout the trial for ignition period.

Run

The relay module is now in RUN and remains in RUN until the controller input, terminal 6 (terminal 17 if in VPS mode), opens, indicating that the demand is satisfied or a limit has opened.

Post-Purge

After demand is satisfied or a limit opens, de-energizing terminal 6 (terminal 17 if in VPS mode), Pilot valve, main valve 1, main valve 2, terminals 8, 9 and 21, are de-energized. The blower motor, terminal 4, remains powered during the specified programmed time. The Pre-Ignition Interlock closes within the first five seconds of Post Purge.

The Valve Proving test is conducted concurrent with the Post-Purge if options Split, Both or After are enabled.

Run/Test Switch

The Run/Test Switch is located on the top side of the relay module, see Fig. 24. The Run/Test Switch allows the burner sequence to be altered as follows:

1. In the measured PREPURGE sequence, the Run/Test Switch, placed in the TEST position, causes the PREPURGE timing to stop.
2. In the Pilot Flame Establishing Period, the Run/Test Switch, placed in the TEST position, stops the timer during the first eight seconds of a ten-second PFEP selection or during the first three seconds of a four-second PFEP selection. It also allows for pilot turn-down test and other burner adjustments. This activates a fifteen-second flameout timer that permits pilot flame adjustment without nuisance safety shutdowns. The Run/Test Switch is ignored during PFEP for the C relay module if terminals 8 and 9 or 9 and 21 are jumpered.

IMPORTANT

When the relay module is switched to the TEST mode, it stops and holds at the next Run/Test Switch point in the operating sequence. Make sure that the Run/Test Switch is in the RUN position before leaving the installation.

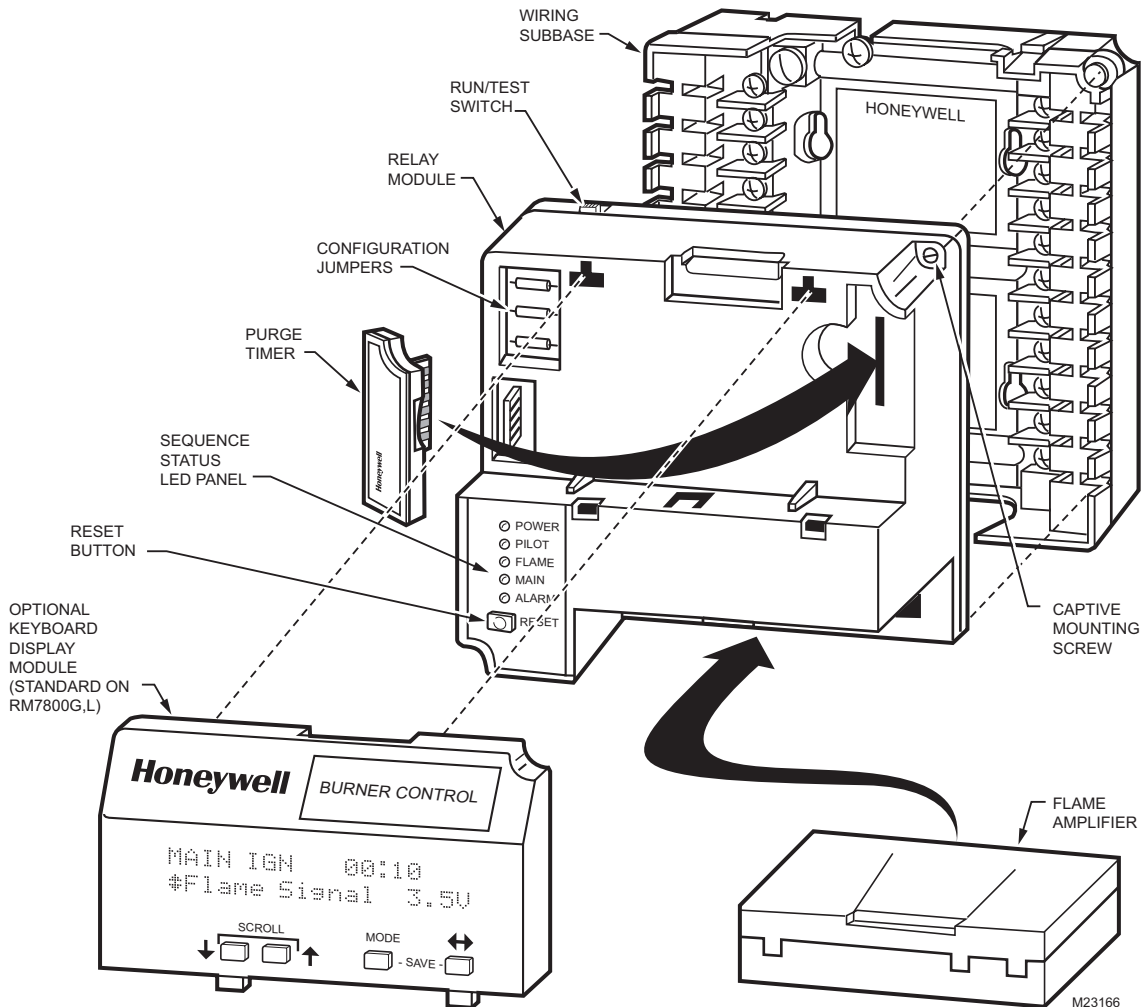

Fig. 24. Sequence Status LEDs.

SETTINGS AND ADJUSTMENTS

Selectable Site-Configurable Jumpers

The relay module has three site-configurable jumper options, see Fig. 25 and Table 8. If necessary, clip the site-configurable jumpers with side cutters and remove the resistors from the relay module.

SERVICE NOTE: Clipping and removing a site-configurable jumper enhances the level of safety.

IMPORTANT

Clipping and removing a jumper after 200 hours of operation causes a nonresettable Fault 110. The relay module must then be replaced.

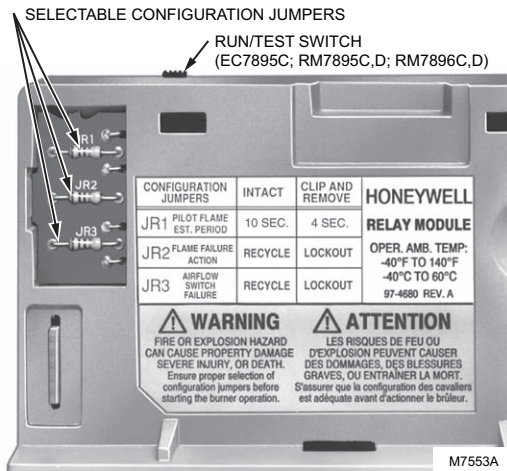

Fig. 25. Selectable site-configurable jumpers.

Table 8. Site-configurable jumper options.

Jumper Number	Description	Intact	Clipped
JR1	Pilot Flame Establishing Period (PFEP)	10 seconds	4 seconds
JR2	Flame Fail	Recycle	Lockout
JR3	Interlock	Recycle	Lockout

TROUBLESHOOTING

The POWER LED provides fault identification when the Relay Module locks out on an alarm. Fault identification is a series of fast- and slow-blinking LED lights. The fast blinks identify the tens portion of the code (three fast blinks is 30), while the slow blinks identify the units portion of the code (two slow blinks is 2). Three fast blinks followed by two slow blinks would be code 32. This identifies a running interlock on during STANDBY. (See Table 9 for Blink Fault Code List.)

The LED code repeats as long as the fault exists. To clear the fault, press the RESET button.

Table 9. Blinking Fault Codes and Recommended Troubleshooting.

Blink Code	System Failure	Recommended Troubleshooting
Code 1-1 *Low AC Line Voltage*	Low AC Line detected.	<ol style="list-style-type: none"> 1. Check the Relay Module and Display Module connections. 2. Reset and sequence the Relay Module. 3. Check the 7800 power supply and make sure that frequency and voltage meet specifications. 4. Check the backup power supply, as appropriate.
Code 1-2 *AC Quality Problem*	Excessive noise or device running on slow, fast, or AC line dropout detected.	
Code 2-1 *Unexpected Flame Signal*	Flame sensed when no flame is expected during STANDBY or PURGE.	<ol style="list-style-type: none"> 1. Check that flame is not present in the combustion chamber; correct any errors. 2. Make sure that the flame amplifier and flame detector are compatible. 3. Check the wiring and correct any errors. 4. Remove the flame amplifier and inspect its connections. Reseat the amplifier. 5. Reset and sequence the Relay Module. 6. If the code reappears, replace the flame amplifier and/or the flame detector. 7. If the fault persists, replace the Relay Module.
Code 2-2 *Flame Signal Absent*	No-flame time present at the end of the Pilot Flame Establishing Period; lost during the Main Flame Establishing Period or during RUN.	<ol style="list-style-type: none"> 1. Measure the flame signal. If one exists, verify that it meets specifications. 2. Make sure that the flame amplifier and flame detector are compatible. 3. Inspect the main fuel valve(s) and valve connection(s). 4. Verify that the fuel pressure is sufficient to supply fuel to the combustion chamber. Inspect the connections to the fuel pressure switches. Make sure they are functioning properly. 5. Inspect the Airflow Switch and make sure that it is functioning properly. 6. Check the flame detector sighting position; reset and recycle. Measure the flame signal strength. Verify that it meets specifications. If not, refer to the flame detector and/or flame amplifier checkout procedures in the installation instructions. 7. Replace the flame amplifier and/or the flame detector, if necessary. 8. If the fault persists, replace the Relay Module.

Table 9. Blinking Fault Codes and Recommended Troubleshooting. (Continued)

Blink Code	System Failure	Recommended Troubleshooting
Code 2-3 *Flame Signal Overrange*	Flame signal value is too high to be valid.	<ol style="list-style-type: none"> 1. Make sure the flame detector and flame amplifier are compatible. 2. Remove the flame amplifier and inspect its connections. Reset the flame amplifier. 3. Reset and sequence the Relay Module. 4. Check the flame detector sighting position; reset and recycle. Measure flame strength. Verify that it meets specifications. If not, refer to the flame detector and/or flame amplifier checkout procedures in the installation instructions. 5. If the code reappears, replace the flame amplifier and/or the flame detector. 6. If the fault persists, replace the Relay Module.
Code 3-1 *Running/ Interlock Switch Problem*	Running or Lockout Interlock fault during Pre-Purge.	<ol style="list-style-type: none"> 1. Check wiring; correct any errors. 2. Inspect the fan; make sure there is no air intake blockage and that it is supplying air. 3. Make sure the Lockout Interlock switches are functioning properly and the contacts are free from contaminants. 4. Reset and sequence the Relay Module to Pre-Purge (place the TEST/RUN Switch in the TEST position, if available). Measure the voltage between terminal 7 and G (ground); 120 Vac should be present. Switch TEST/RUN back to RUN. 5. If steps 1 through 4 are correct and the fault persists, replace the Relay Module.
Code 3-2 *Running/ Interlock On During Standby*	Lockout Interlock powered at improper point in sequence or On in Standby.	<ol style="list-style-type: none"> 1. Check wiring to make sure that the Lockout Interlocks are connected properly between terminals 6 and 7. Correct any errors. 2. Reset and sequence the Relay Module. 3. If the fault persists, measure the voltage between terminal 6 and G (ground), then between terminal 7 and G. If there is 120 Vac at terminal 6 when the controller is off, the controller switch may be bad or is jumpered. 4. If steps 1 through 3 are correct and there is 120 Vac at terminal 7 when the controller is closed and the fault persists, check for a welded or jumpered Running Interlock or Airflow Switch. Correct any errors. 5. If steps 1 through 4 are correct and the fault persists, replace the Relay Module.
Code 3-3 *VPS in Improper State*	VPS (Valve Proving Switch) in wrong state during VPS Test.	<ol style="list-style-type: none"> 1. Check wiring, making sure upstream valve is connected to terminal 9 and downstream valve is connected to terminal 17. 2. Conduct Valve Seat leakage test using a manometer. 3. Reset and sequence the Relay Module; if fault repeats, test VPS (connected to terminal 16) is functioning properly; replace if necessary. 4. Reset and sequence the Relay Module. 5. If fault persists, replace the Relay Module.
Code 4-1 *Purge Card Problem*	No purge card or the purge card timing has changed from the original configuration.	<ol style="list-style-type: none"> 1. Make sure the purge card is seated properly. 2. Inspect the purge card and the connector on the Relay Module for any damage or contaminants. 3. Reset and sequence the Relay Module. 4. If the fault code reappears, replace the purge card. 5. Reset and sequence the Relay Module. 6. If the fault code persists, replace the Relay Module.
Code 4-2 *Wiring Problem/ Internal Fault*	Pilot (ignition) valve terminal, main valve, ignition or Main Valve 2 was on when it should be off.	<p>⚠ WARNING Electrical Shock Hazard; Fire or Explosion Hazard. Can cause severe injury, death or property damage. Remove system power and turn off power supply.</p> <ol style="list-style-type: none"> 1. Remove system power and turn off fuel supply. 2. Check wiring; correct any errors. 3. inspect Pilot Fuel Valve(s), both places, and connections. 4. Reset and sequence the Relay Module. 5. If the fault persists, replace the Relay Module.
Code 4-3 *Flame Amplifier Problem*	Flame not sensed, or sensed when it should be on or off.	<ol style="list-style-type: none"> 1. Check wiring; correct any errors. 2. Make sure the flame amplifier and flame detector are compatible. 3. Remove the flame amplifier and inspect the connections. Reseat the amplifier. 4. Reset and sequence the Relay Module. 5. If the code reappears, replace the flame amplifier and/or the flame detector. 6. If the fault persists, replace the Relay Module.

Table 9. Blinking Fault Codes and Recommended Troubleshooting. (Continued)

Blink Code	System Failure	Recommended Troubleshooting
Code 4-4 *Configuration Jumper Problem*	The configuration jumpers differ from the sample taken at startup.	<ol style="list-style-type: none"> 1. Inspect the jumper connections. Make sure the clipped jumpers were completely removed. 2. Reset and sequence the Relay Module. 3. If the fault persists, replace the Relay Module.
Code 5-1 *Pre-Ignition Interlock*	Pre-Ignition Interlock fault.	<ol style="list-style-type: none"> 1. Check wiring and correct any errors. 2. Check Pre-Ignition Interlock switches to assure proper functioning. 3. Check fuel valve operation. 4. Reset and sequence the Relay Module; monitor the Pre-Ignition Interlock status. 5. If the fault persists, replace the Relay Module.
Code 5-2 *High Fire Sw. or Low Fire Sw.*	Either High Fire Switch or Low Fire Switch failure.	<ol style="list-style-type: none"> 1. Check wiring and correct any errors. 2. Reset and sequence the Relay Module. 3. Use manual motor potentiometer to drive the motor open and closed. Verify at motor switch that the end switches are operating properly. Use RUN/TEST switch if manual potentiometer is not available. 4. Reset and sequence the Relay Module. 5. If the fault persists, replace the Relay Module.
Code 5-3 *Man-Open Sw.; Start Sw. or Control On*	Man-Open Switch, Start Switch or Control On in the wrong operational state.	<ol style="list-style-type: none"> 1. Check wiring and correct any errors. 2. Make sure that the Manual Open Valve Switch, Start Switch and Control are operating properly. 3. Stat Switch held "On" too long. 4. Reset and sequence the Relay Module. 5. Reset and sequence the Relay Module. If the fault persists, replace the Relay Module (RM7838A1014; RM7838B1013 or RM7838C1004 only).
Code 6-1 *Internal Faults*	Relay Module self-test failure.	<ol style="list-style-type: none"> 1. Reset and sequence the Relay Module. 2. If fault reappears, remove power from the device, reapply power, then reset and sequence the Relay Module. 3. If the fault persists, replace the Relay Module.
Code 6-2 *Internal Faults*	Relay Module Self-Test failure.	<ol style="list-style-type: none"> 1. Reset and sequence the Relay Module. 2. If fault reappears, remove power from the device, reapply power, then reset and sequence the Relay Module. 3. If fault does not repeat on the next cycle, check for electrical noise being copied into the Relay Module through the external loads or possibly an electrical grounding issue. 4. If the fault persists, replace the Relay Module.
Code 6-3 *Device Specific*	Fault with special OEM input circuits.	<ol style="list-style-type: none"> 1. Check wiring and operation of special OEM inputs. 2. Reset and sequence the Relay Module. 3. If fault reappears, remove power from the device, reapply power, then reset and sequence the Relay Module. 4. If the fault does not repeat on the next cycle, check for electrical noise being copied into the Relay Module through the external loads or possibly an electrical grounding issue. 5. If the fault persists, replace the Relay Module.
Code 6-4 *Accessory Fault*	VPS setup	<ol style="list-style-type: none"> 1. Make sure RM VP is programmed. 2. T6 and T17 powered at the same time—correct wiring. 3. Reset control if fault persists. Replace relay module.
Code 7-7 *Unused*	Unused at this time.	—

APPENDIX A: VALVE PROVING TEST

The Valve Proving System feature offers a systematic way of testing the valve seat integrity to assure the valves are indeed in the closed position when the system is off-line, in STANDBY.

⚠ WARNING

Explosion Hazard.
Can cause severe injury, death or property damage.

Leaking gas valves can result in fire or explosion. The Valve Proving System is designed to detect such leaks. A Valve Proving test time that is too short may allow unacceptable leaks to go undetected. Use the procedure in Appendix A to select sufficient valve test times to detect any unacceptable leak.

The following steps are to determine the test time for the Relay Module to verify the valve seats are not leaking at a rate of greater than/equal to 0.1% of the burner capacity.

Fig. 26 shows a typical valve train. The legend identifies information that will be used to fill out the worksheet that appears at the end of this appendix.

1. Identify items of your system and fill in the "Information" portion of the worksheet.
2. Go to the Lookup Tables noted (12, 13 or 14) to get the results for your system.

IMPORTANT

The tables show information on Honeywell Valves only. Contact other valve manufacturers to obtain data on their specific valves.

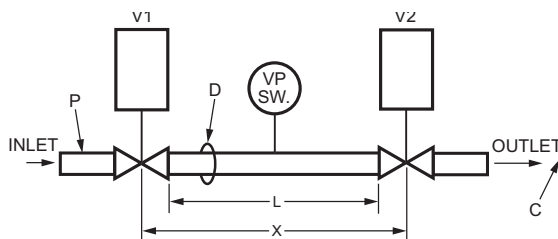

LEGEND

- V1 UPSTREAM VALVE
- V2 DOWNSTREAM VALVE
- D PIPE DIAMETER (IN INCHES.) USED TO DETERMINE A; ARE FOUND IN TABLE III
- L PIPE LENGTH (IN FEET)
- P VALVE INLET PRESSURE (PSIG)
- C BURNER MAX. FIRING (CFH)
- X CALCULATED TEST VALVE TRAIN VOLUME

M22778

Fig. 26. Typical valve train layout.

3. Use appropriate Results column items to fill in the Valve Train Volume Formula and the Calculation of Valve Proving Test Time.
4. Round up the time to the nearest second.
5. The test time calculated is the time you will enter into the VPS Setup.

Calculation of Valve Train Volume

$$X = V1 + V2 + (A \times L / 144)$$

Calculation of Valve Proving Test Time

$$\text{Test Time} = 187,000 \times (P \times X) / C$$

Table 10. Valve Proving Test Time Symbols and Descriptions.

Symbol	Unit	Description
X	ft ³	Volume between the two valves to be tested.
V ₁	ft ³	Volume of upstream valve outlet cavity.
V ₂	ft ³	Volume of downstream valve inlet cavity.
L	ft	Length of pipe between valves.

Symbol	Unit	Description
D	npt	Pipe Size—used to define A
A	in. ²	Pipe Cross Section Area (from Table 14)
Test Time	Seconds	Minimum VPS test period.
P	psi	Gas inlet pressure to upstream valve.
C	ft ³ /hr	Burner Capacity.

NOTE: V1 is the outlet cavity of the upstream valve and V2 is the inlet cavity of the downstream valve.

NOTE: 10 seconds is the minimum test time allowed. If your calculations are less than 10 seconds, enter 10 seconds.

For Example:

We have a 2.5 MBTU burner with 2 psi valve train inlet pressure. The upstream valve is a proof-of-closure V5044 with a solenoid V4295 valve downstream. We have a 2 in. NPT pipe, 1-3/4 ft long, between the valves.

Table 11. VPS Worksheet Example.

Item	Description	Information	Lookup Table	Results	Formula Item
V1	Upstream Valve Volume	V5055	12	0.0218	V1
V2	Downstream Valve Volume	V4295	13	0.0267	V2
D	Pipe Size NPT (in.)	2 in. NPT	14	3.356	A
L	Pipe Length (ft)	1.75 ft	—	1.75	L
P	Valve Inlet Pressure (psig) ^a	2	—	2	P
C	Burner Maximum Firing (cf/hr) ^b	2.5 mbtu	—	2500	C

^a Divide inches w.c. by 27.7 to get psi.

^b Divide Btuh by 1000 to get cf/hr for natural gas or by 2550 to get cf/hr for LP gas.

Calculation of Valve Train Volume:

$$\text{Test Time} = 187,000 \times (P \times X \div C)$$

$$X = V1 + V2 + (A \times L \div 144)$$

$$\text{Test Time} = 187,000 \times (2 \times 0.0893 \div 2500) = 13.4 \text{ seconds.}$$

$$X = 0.0218 + 0.0267 + (3.356 \times 1.75 \div 144) = 0.0893.$$

Round up to 14 seconds; enter 14 seconds into the VPS Setup.

Calculation of Valve Proving Test Time:

Table 12. V1 Upstream Volumes for Honeywell Valves.

Pipe Size NPT (inches)	V4295	V4297A1013	V4297A1005	V48	V5055	V5097A1004	V5097A1012
3/8	0.0002	—	—	—	—	—	—
1/2	0.0002	—	—	—	—	—	—
3/4	0.0008	0.0093	0.0090	0.0010	0.0046	0.0066	—
1	0.0009	0.0093	0.0090	0.0010	0.0046	0.0066	—
1-1/4	0.0045	0.0093	0.0090	0.0035	0.0046	0.0066	—
1-1/2	0.0045	0.0093	—	0.0035	0.0218	0.0066	—
2	0.0089	0.0093	—	0.0048	0.0218	0.0066	0.0285
2-1/2	0.0441	—	—	0.0048	0.0227	—	0.0285
3	0.0441	—	—	0.0048	0.0227	—	0.0285
4	—	—	—	—	0.0779	—	—

Table 13. V2 Downstream Volumes for Honeywell Valves.

Pipe Size NPT (inches)	V4295	V4297A1013	V4297A1005	V48	V5055	V5097A1004	V5097A1012
3/8	0.0011	—	—	—	—	—	—
1/2	0.0011	—	—	—	—	—	—
3/4	0.0026	0.0282	0.0232	0.0048	0.0067	0.0093	—
1	0.0036	0.0282	0.0232	0.0048	0.0067	0.0093	—
1-1/4	0.0148	0.0282	0.0232	0.0110	0.0067	0.0093	—
1-1/2	0.0148	0.0282	—	0.0110	0.0238	0.0093	—
2	0.0267	0.0282	—	0.0184	0.0238	0.0093	0.0303
2-1/2	0.0554	—	—	0.0184	0.0245	—	0.0303
3	0.0554	—	—	0.0184	0.0245	—	0.0303
4	—	—	—	—	0.0801	—	—

Table 14. Schedule 40 Pipe Internal Cross-Sectional Area.

Pipe Size NPT (Inches)	Cross-Sectional Area (Sq. In.) "A"
3/8	0.191
1/2	0.304
3/4	0.533
1	0.864
1-1/4	1.498
1-1/2	2.036
2	3.356
2-1/2	4.788
3	7.393
4	12.730

Table 15. VPS Worksheet.

Item	Description	Information	Lookup Table	Results	Formula Item
V1	Upstream Valve Volume		12		V1
V2	Downstream Valve Volume		13		V2
D	Pipe Size NPT (in.)		14		A
L	Pipe Length (ft)		—		L
P	Valve Inlet Pressure (psig) ^a		—		P
C	Burner Maximum Firing (cf/hr) ^b		—		C

^a Divide inches w.c. by 27.7 to get psi.

^b Divide Btuh by 1000 to get cf/hr for natural gas or by 2550 to get cf/hr for LP gas.

APPENDIX B - IGNITION OPTIONS

Column 1 lists the ignition options.

Column 2 lists the drawing that provides that option. The letter refers to drawings on pages 24–28.

Column 3 refers to the number of poles required on the Fuel Changeover Switch.

Table 16. Ignition options.

IGNITION OPTIONS		DRAWING I.D. CODE	FUEL CHANGEOVER POLES REQUIRED
NO VALVE PROVING			
Single Fuel			
Interrupted Pilot		A	--
Intermittent Pilot		B	--
Direct Spark Ignition		C	--
Dual Fuel			
Gas	Oil		
10 sec. Interrupted Pilot	10 sec. Interrupted Pilot	D	2
10 sec. Interrupted Pilot	Intermittent Pilot	E	2
10 sec. Interrupted Pilot	Direct Spark Ignition	F	3
Intermittent Pilot	10 sec. Interrupted Pilot	G	2
Intermittent Pilot	Intermittent Pilot	H	2
Intermittent Pilot	Direct Spark Ignition	I	3
Direct Spark Ignition	10 sec. Interrupted Pilot	J	3
Direct Spark Ignition	Intermittent Pilot	K	3
Direct Spark Ignition	Direct Spark Ignition	L	2
VALVE PROVING			
Single Fuel			

Table 16. Ignition options. (Continued)

IGNITION OPTIONS		DRAWING I.D. CODE	FUEL CHANGEOVER POLES REQUIRED
NO VALVE PROVING			
10 Sec. Interrupted Pilot		M	--
Intermittent Pilot		N	--
Direct Spark Ignition		O	--
Dual Fuel			
Gas	Oil	P	2
10 sec. Interrupted Pilot	10 sec. Interrupted Pilot	Q	3
10 sec. Interrupted Pilot	Direct Spark Ignition	R	4
10 sec. Interrupted Pilot	Direct Spark Ignition	S	3
Intermittent Pilot	10 sec. Interrupted Pilot	T	3
Intermittent Pilot	Direct Spark Ignition	U	4
Direct Spark Ignition	10 sec. Interrupted Pilot	V	3
Direct Spark Ignition	Intermittent Pilot	W	3
Direct Spark Ignition	Direct Spark Ignition	X	3

Gas Direct Spark Ignition during VPS Selection (powering terminal 19) automatically chooses 4 second Ignition Trial Period, regardless of configuration of resistor JR1 status.

⚠ CAUTION

The above options are **ONLY** suggestions—**BE SURE** to check local approval agencies for timings acceptable for your application.

RM7898A IGNITION OPTIONS

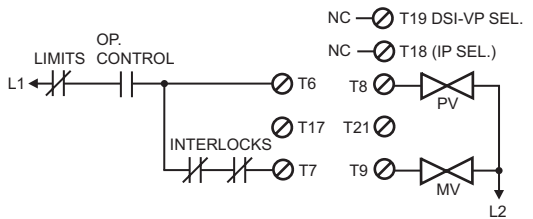

A. SINGLE FUEL: 10 SECOND INTERRUPTED PILOT
M24138

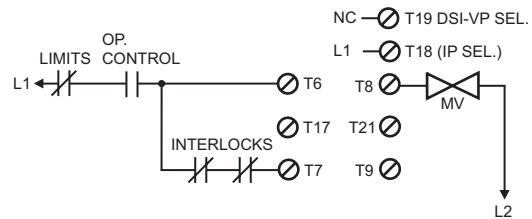

C. SINGLE FUEL: DIRECT SPARK IGNITION
M24140

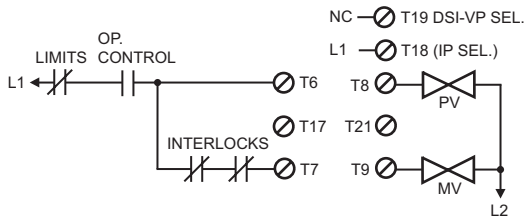

B. SINGLE FUEL: INTERMITTENT PILOT
M24139

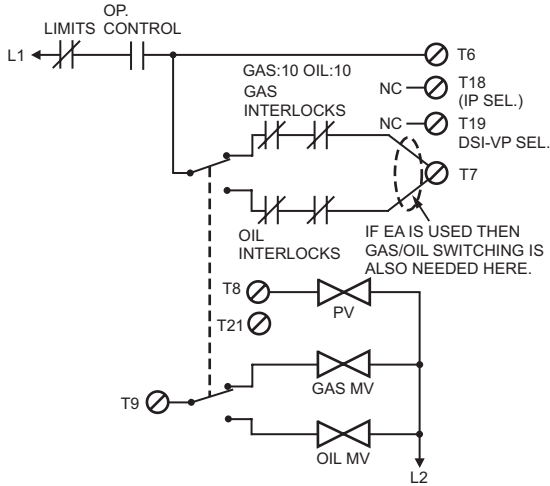

D. DUAL FUEL: BOTH 10 SECOND INTERRUPTED GAS PILOT
M24175

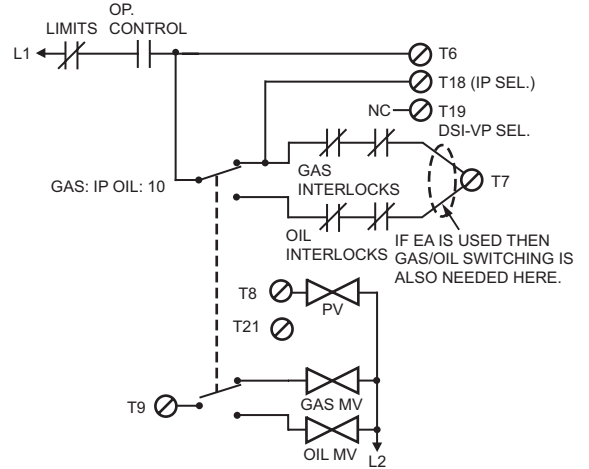

G. DUAL FUEL: GAS INTERMITTENT PILOT, OIL 10 SECOND INTERRUPTED GAS PILOT.
M24170

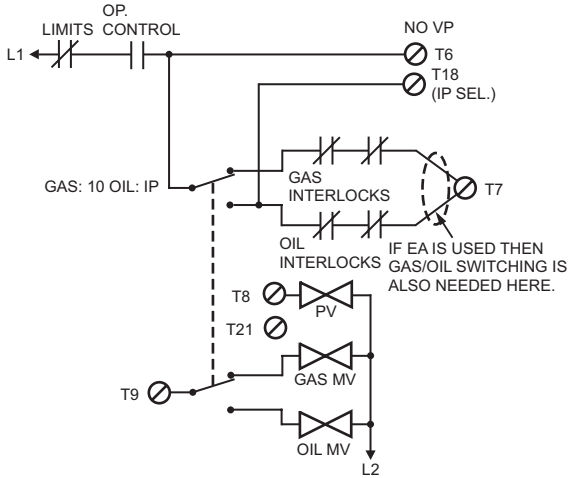

E. DUAL FUEL: GAS 10 SECOND INTERRUPTED PILOT, OIL INTERMITTENT PILOT
M24142

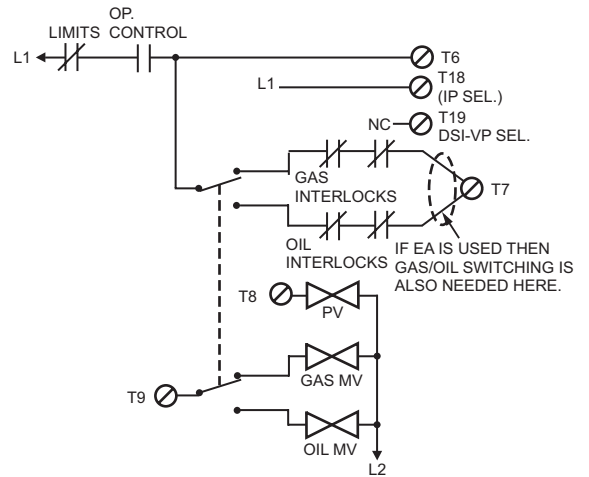

H. DUAL FUEL GAS/OIL INTERMITTENT GAS PILOT
M24150

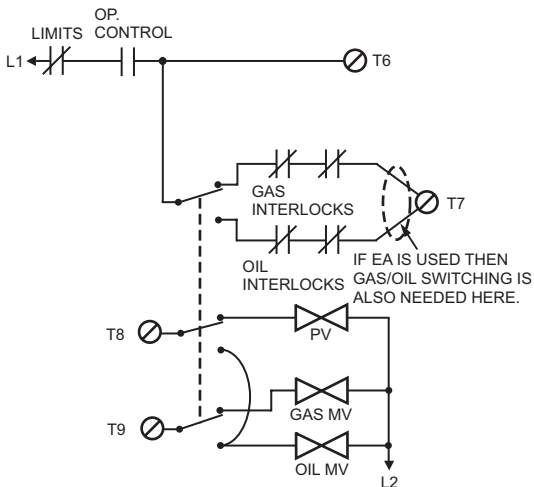

F. DUAL FUEL: GAS 10 SECOND INTERRUPTED PILOT, OIL: DIRECT SPARK IGNITION
M24144

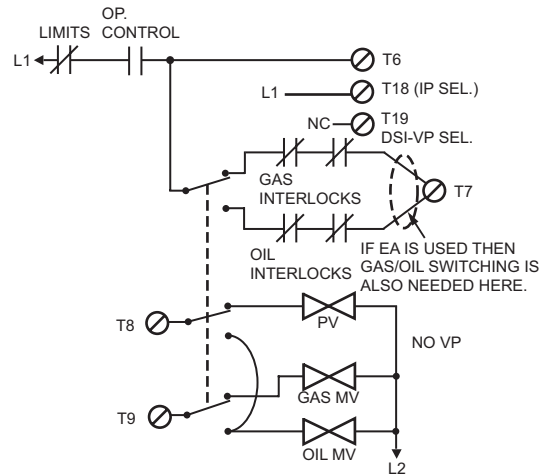

I. DUAL FUEL: GAS INTERMITTENT PILOT, DIRECT SPARK OIL
M24171

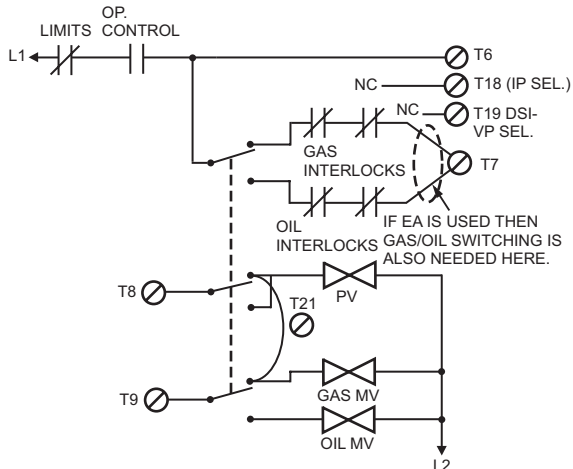

J. DUAL FUEL: GAS IS DSI, OIL IS 10 SECOND INTERRUPTED PILOT

M24148

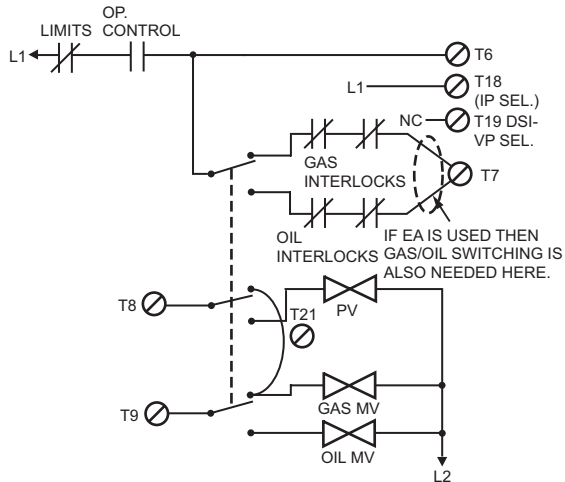

K. DUAL FUEL: GAS IS DSI, OIL IS INTERMITTENT GAS PILOT

M24173

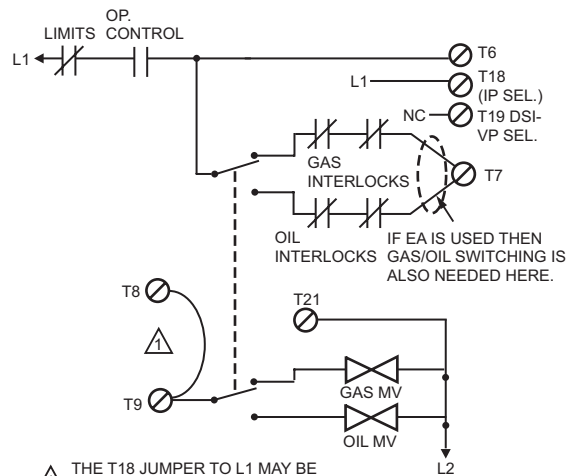

L. DUAL FUEL: DSI GAS AND OIL

M24149

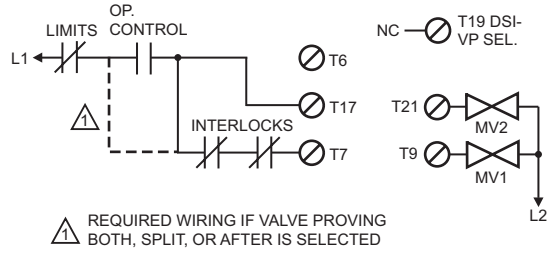

M. VALVE PROVING, GAS: 10 SECOND INTERRUPTED PILOT

M24176

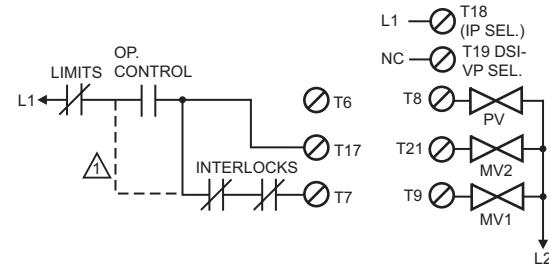

N. VALVE PROVING, GAS ONLY: INTERMITTENT PILOT

M24177

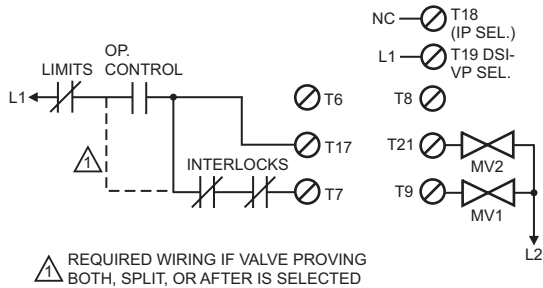

O. VALVE PROVING, GAS ONLY: DIRECT SPARK IGNITION

M24178

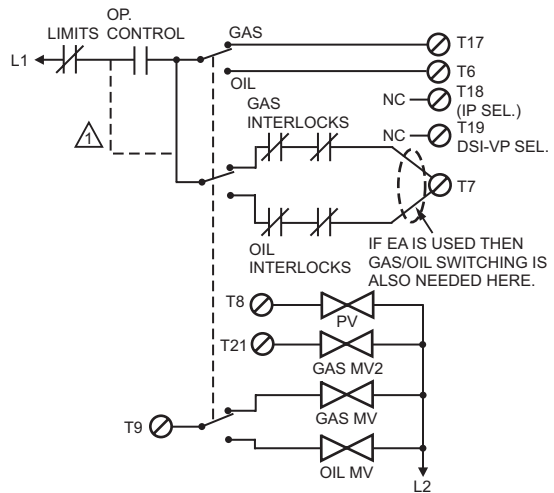

P. VALVE PROVING, DUAL FUEL: BOTH 10 SECOND INTERRUPTED GAS PILOT

M24141

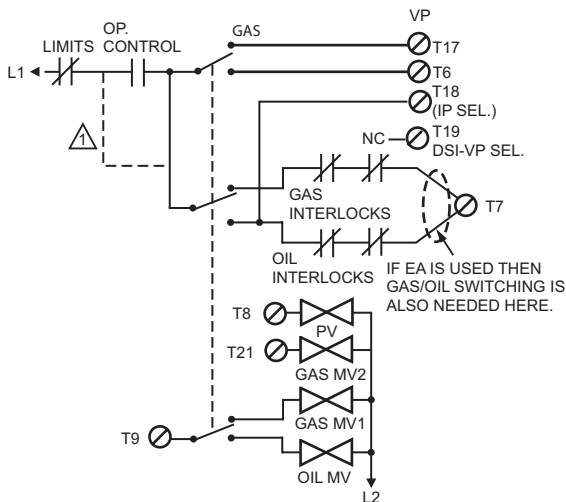

⚠ REQUIRED WIRING IF VALVE PROVING BOTH, SPLIT, OR AFTER IS SELECTED

Q. VALVE PROVING, DUAL FUEL: GAS 10 SECOND INTERRUPTED PILOT, OIL IS INTERMITTENT PILOT

M24146

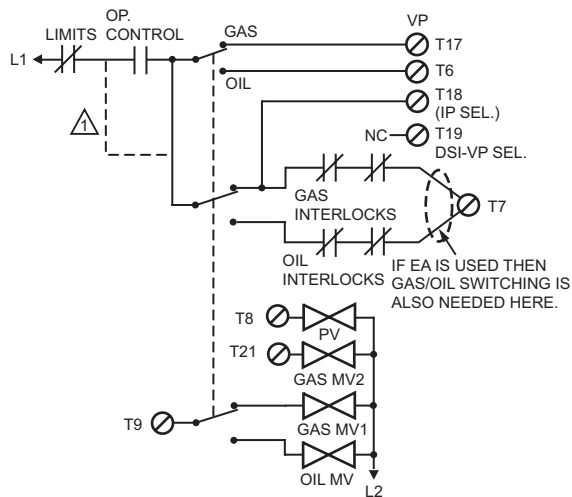

⚠ REQUIRED WIRING IF VALVE PROVING BOTH, SPLIT, OR AFTER IS SELECTED

S. VALVE PROVING, DUAL FUEL: GAS INTERMITTENT PILOT, OIL 10 SECOND INTERRUPTED GAS PILOT

M24143

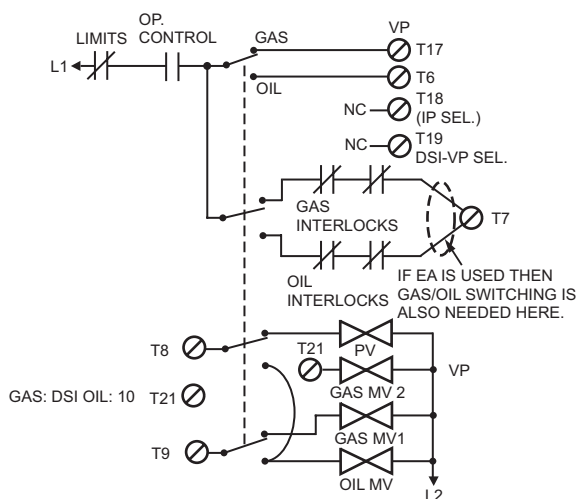

R. VALVE PROVING: GAS 10 SECOND INTERRUPTED PILOT, OIL DIRECT SPARK IGNITION

M24179

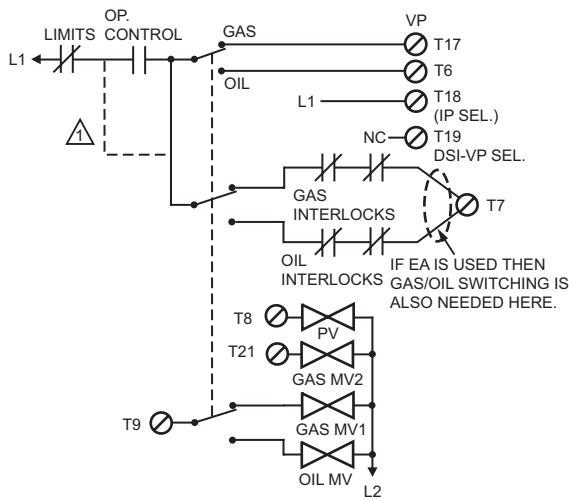

⚠ REQUIRED WIRING IF VALVE PROVING BOTH, SPLIT, OR AFTER IS SELECTED

T. VALVE PROVING, DUAL FUEL: BOTH INTERMITTENT GAS PILOT VALVE

M24147

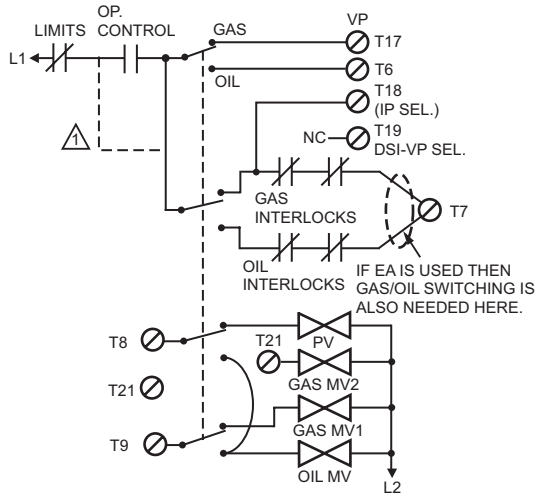

⚠ REQUIRED WIRING IF VALVE PROVING BOTH, SPLIT, OR AFTER IS SELECTED

U. VALVE PROVING, DUAL FUEL: GAS INTERMITTENT PILOT, OIL DIRECT SPARK

M24172

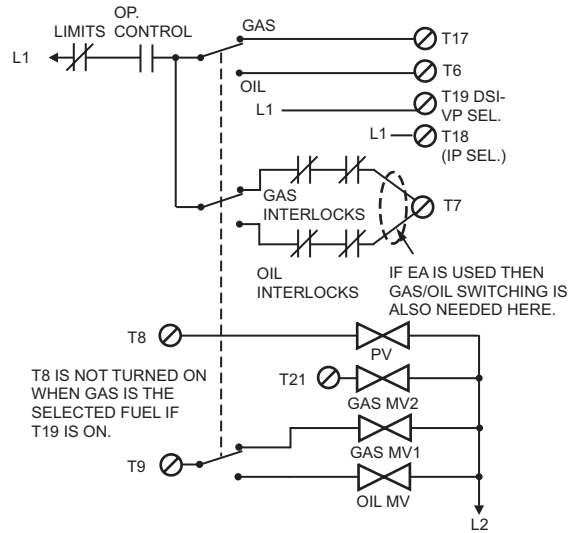

W. VALVE PROVING, DUAL FUEL: GAS DSI, OIL INTERMITTENT PILOT

M24181

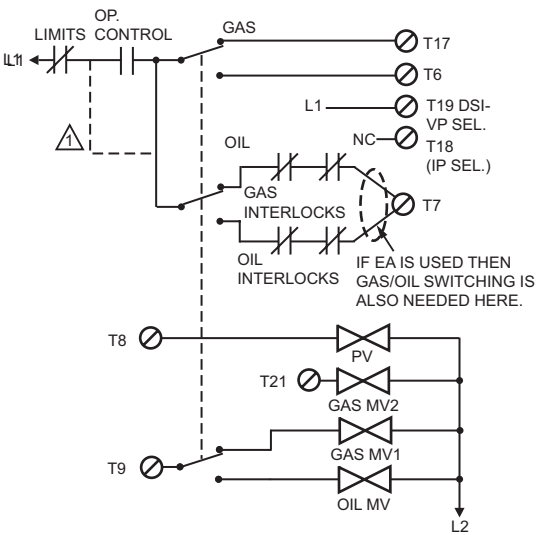

⚠ REQUIRED WIRING IF VALVE PROVING BOTH, SPLIT, OR AFTER IS SELECTED

V. VALVE PROVING, DUAL FUEL: GAS DIRECT SPARK, OIL 10 SECOND INTERRUPTED

M24180

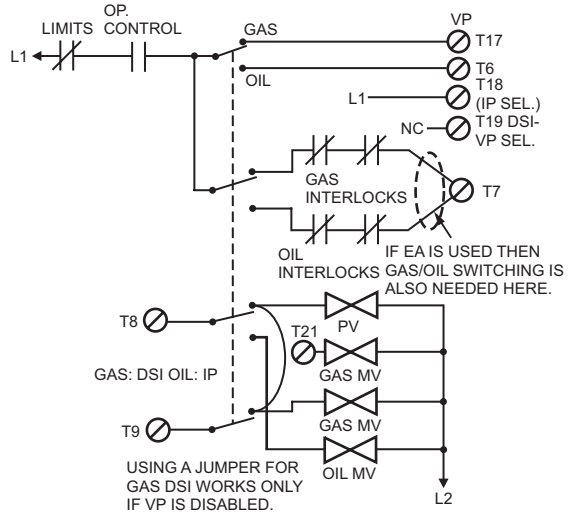

X. VALVE PROVING, DUAL FUEL: GAS IS DIRECT SPARK IGNITION, OIL IS DIRECT SPARK

M24145

Automation and Control Solutions

Honeywell International Inc.
1985 Douglas Drive North
Golden Valley, MN 55422
customer.honeywell.com

Honeywell Limited-Honeywell Limitée
35 Dynamic Drive
Scarborough, Ontario M1V 4Z9

