

T8602A,B,C,D and TS8602A,C Chronotherm® III Fuel Saver Thermostats

INSTALLATION INSTRUCTIONS

APPLICATION

These thermostats provide energy saving control for 24 Vac conventional heating/cooling system or 750 mV heating and 24 Vac cooling as indicated in Table 1.

Power is supplied for the device by three AA alkaline batteries (included). This allows the thermostat to be compatible with all control applications.

Cycle rates are adjustable for heating.

The TS8602 current rating in heating is 0.1A at 750 mV. The current rating on all other models is 1.6A maximum, up to 30 Vac.

Adaptive Intelligent Recovery™/Conventional Recovery selection screw is included on the back of the thermostat.

Fan operation switch is included on the back of some T8602C models to select either independent or direct thermostat control of the fan in heating.

12/24 hour clock conversion and °C/°F conversion are available on some models only.



RECYCLING NOTICE

If this control is replacing a control that contains mercury in a sealed tube, do *not* place your old control in the trash. Contact your local waste management authority for instructions regarding recycling and the proper disposal of your old control.

If you have any questions, call Honeywell Inc. at 1-800-468-1502.

INSTALLATION

When Installing This Product...

- ❶ Read these instructions carefully. Failure to follow them could damage the product or cause a hazardous condition.
- ❷ Check the ratings given on the product to make sure the product is suitable for your application.
- ❸ Installer must be a trained, experienced service technician.
- ❹ After installation is complete, check out product operation as provided in these instructions.
- ❺ Allow thermostat to warm to room temperature before operating.

Table 1. Thermostat Models.

Thermostat	Stages		Switching		Application
	Heat	Cool	System	Fan	
T8602A	1	—	—	—	Gas, oil or electric with independently controlled fan.
T8602B	1	—	—	ON-AUTO	
T8602B	1	—	HEAT-OFF	—	
T8602C	1	1	HEAT-OFF-COOL	ON-AUTO	
T8602D	1	1	HEAT-OFF-COOL-AUTO	ON-AUTO	
T8602C	1	1	HEAT-OFF-COOL	ON-AUTO	Fan operation in heating selectable for thermostat or independent control; with O and B terminals for changeover control.
TS8602A	1	—	—	—	Millivolt heating system.
TS8602C ^a	1	1	HEAT-OFF-COOL	ON-AUTO	Millivolt heating and 24 Vac cooling system.

^a Available only in Canada.



! CAUTION

Disconnect power supply to prevent electrical shock or equipment damage.

Location

Install thermostat and wallplate about 5 ft (1.5m) above the floor in an area with good air circulation at room temperature.

Do not install the thermostat where it can be affected by:

- drafts or dead spots behind doors, in corners, or under cabinets.
- hot or cold air from ducts.
- radiant heat from sun or appliances.
- concealed pipes and chimneys.
- unheated (uncooled) areas such as an outside wall, behind the thermostat.

If Replacing An Existing Thermostat

Turn off power to the thermostat at the furnace or boiler. A two-transformer system can require turning off two switches or disconnects. Remove any existing wallplate or subbase from the wall. Write down the letter or number on each wiring terminal, as the wire is removed, to avoid miswiring later.

If New Installation

Run cable to the hole in the selected wall location, and pull about 3 in. (76 mm) of wire through the opening. Color-coded, 18 gauge thermostat cable with at least one conductor for each wiring terminal is recommended.

Push excess wire back into the hole, and plug the hole with nonhardening caulk, putty or insulation to prevent drafts from affecting the thermostat operation.

Mounting Wallplate

Remove thermostat from wallplate. See Fig. 1.

The wallplate does not require leveling for operation, but for appearance only. The wallplate mounts directly onto the wall with the screws included. Using the wallplate as a template, with a pencil, mark two (of three) mounting screw positions on the wallplate that fit the application. See Fig. 2. Use a 3/16 in. bit to drill holes for the anchors. Gently tap anchors into the holes until flush with the wall surface. Thread wires through the center opening of the wallplate. Mount the wallplate using the two screws provided. Gently tighten the screws, level the top surface of the wallplate, and then securely tighten the screws.

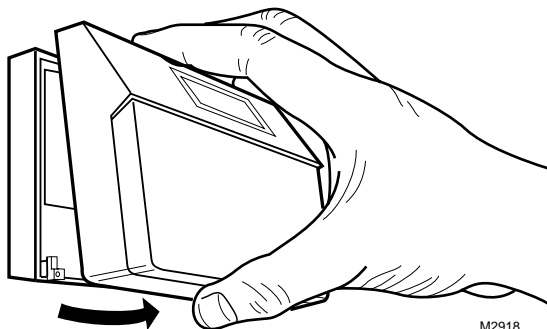

M2918

Fig. 1. Removing thermostat from wallplate.

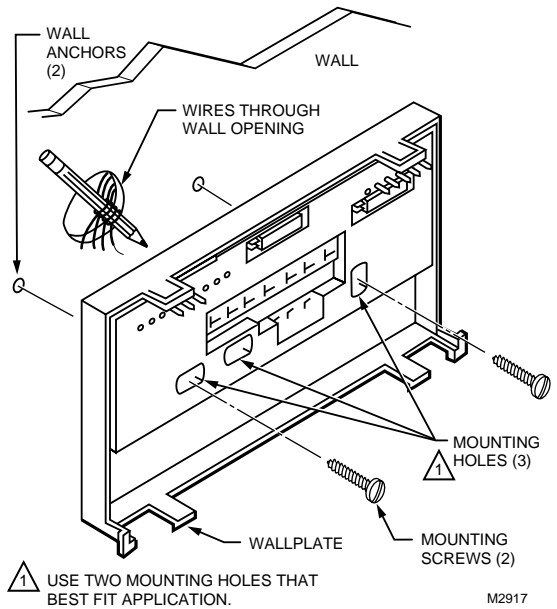

Fig. 2. Mounting wallplate on wall.

Wiring

! CAUTION

The TS8602A,C can only be used on 750 mV heating applications. The TS8602A,C will not function properly on 250 mV, 500 mV or 24 Vac heating applications.

All wiring must comply with local electrical codes and ordinances.

Disconnect power before wiring to prevent electrical shock or equipment damage.

The shape of the terminal barrier permits insertion of straight or conventional wraparound wiring connections. Either method is acceptable.

Refer to Fig. 4 through 15 for typical wallplate and thermostat hookups.

- NOTE:
- Keep all wiring restricted to the ribbed area surrounding the terminals (Fig. 3) to assure thermostat/wallplate contact.
 - For single transformer applications, jumper terminals R and RC for proper operation.

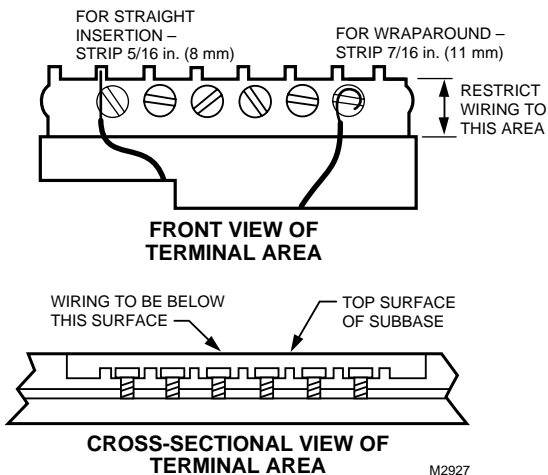

Fig. 3. Keep wiring restricted to the ribbed area surrounding terminals.

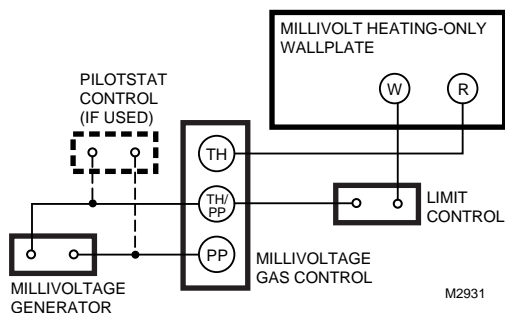

Fig. 4. TS8602 in typical millivoltage heating circuit.

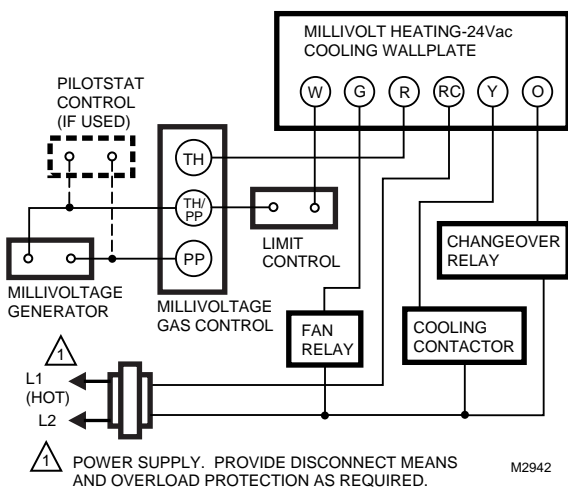

Fig. 5. TS8602C in typical millivoltage heating and 24 Vac cooling circuit.

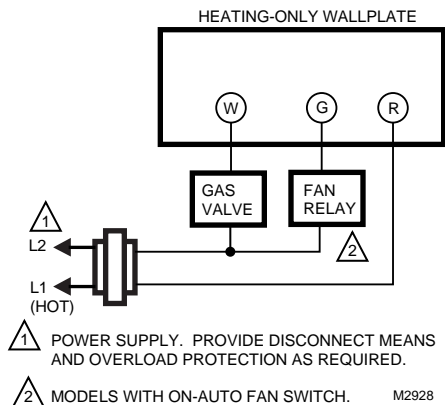

Fig. 6. T8602A,B heating-only circuit in a continuous pilot gas system.

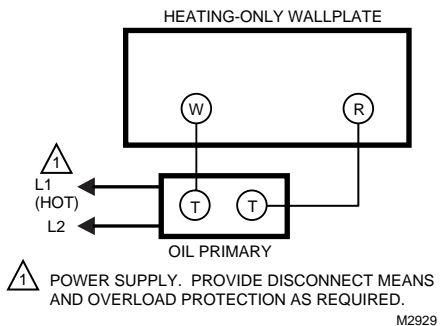

Fig. 7. T8602A,B heating-only circuit in an oil system.

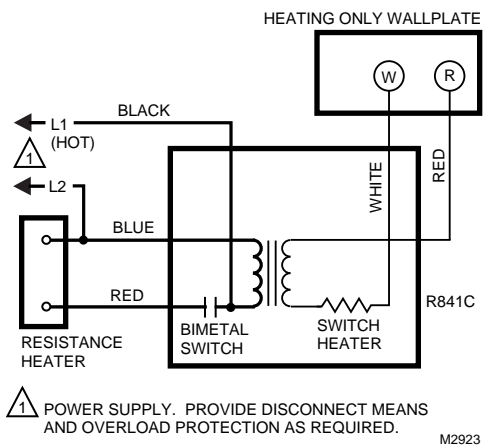
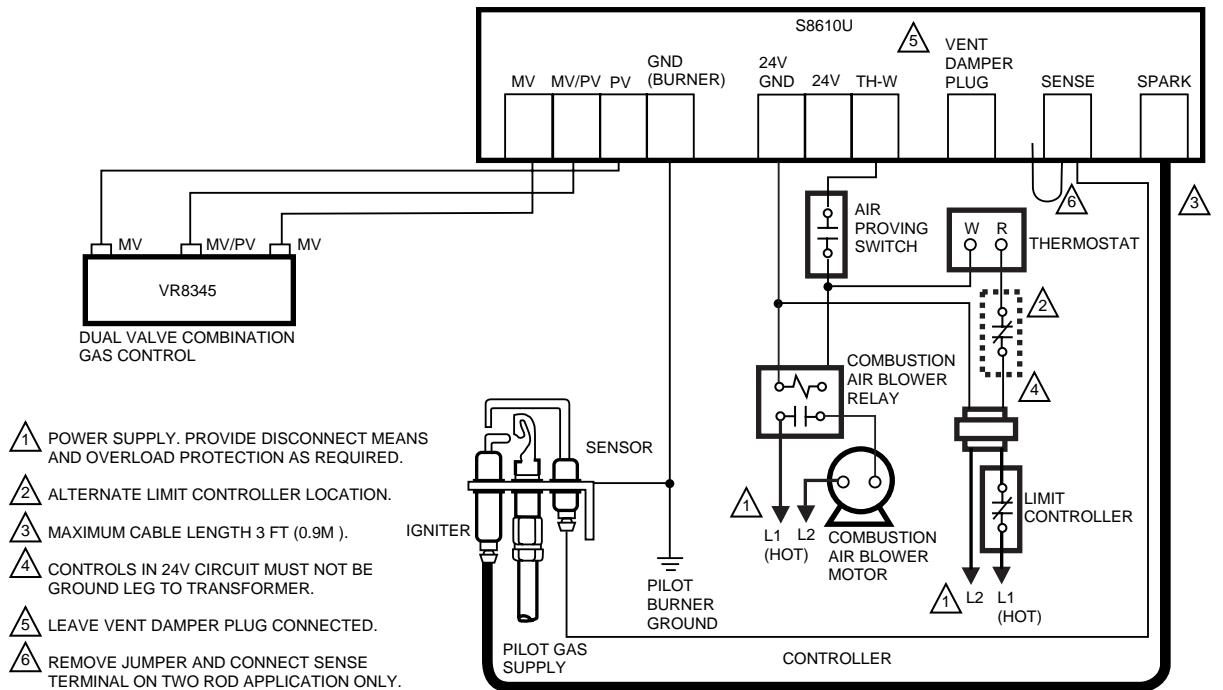
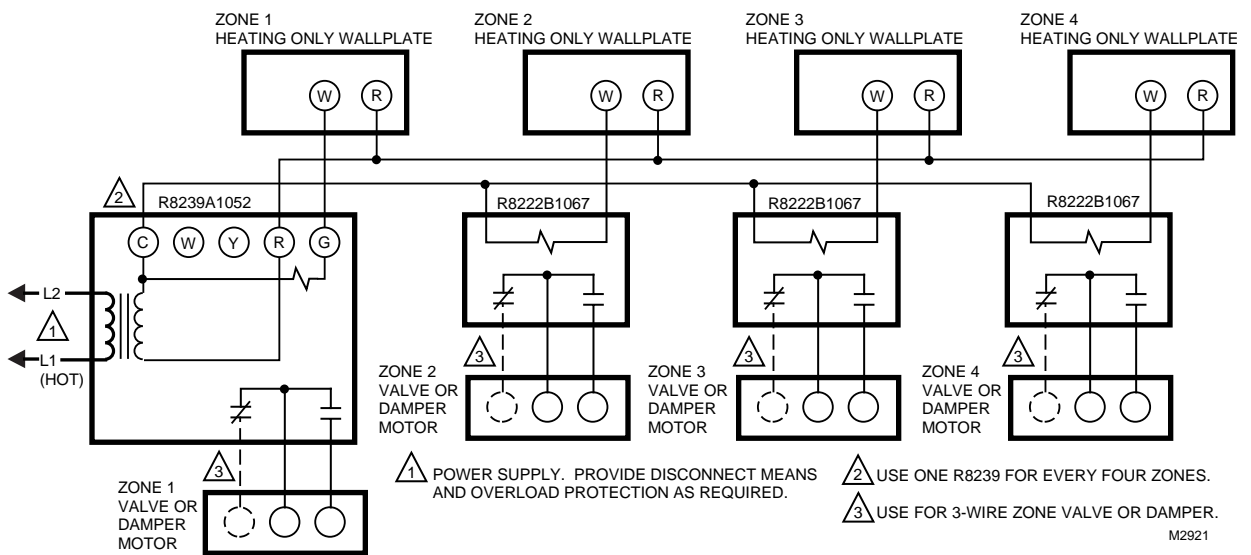

Fig. 8. T8602A,B heating-only circuit in an electric baseboard or ceiling cable system.



M8600

Fig. 9. T8602A,B heating-only circuit in a Honeywell Intermittent Pilot Gas Burner Ignition System.



M2921

Fig. 10. T8602A,B circuit for controlling incompatible or three-wire zone valves or dampers. Heating or cooling equipment is operated by an end switch on the zone valve or motor, or by a thermostat in a master zone.

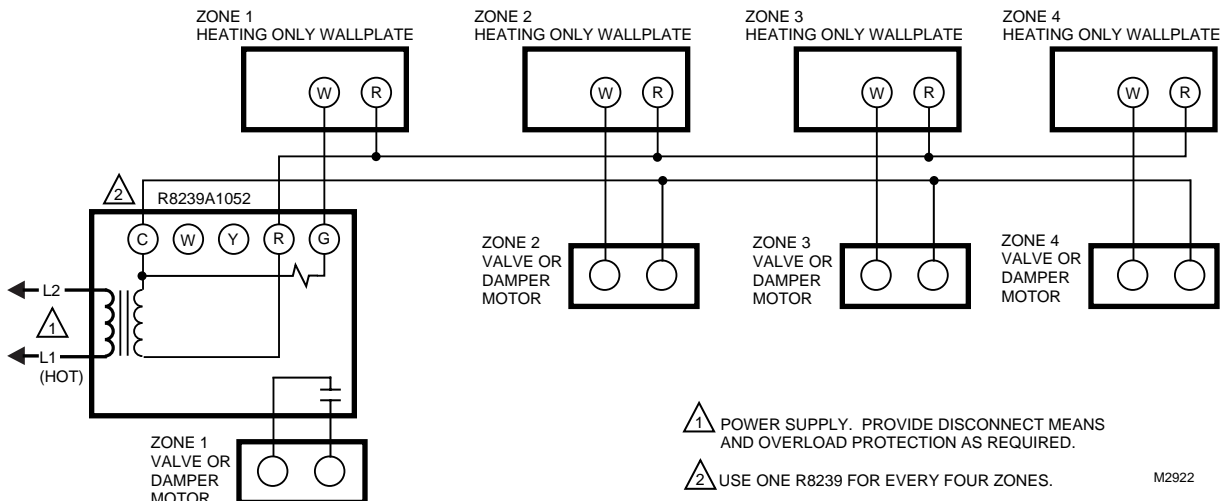

Fig. 11. T8602A,B circuit for controlling Honeywell or compatible two-wire zone valves or dampers. Heating or cooling equipment is operated by an end switch on the zone valve or motor, or by a thermostat in a master zone.

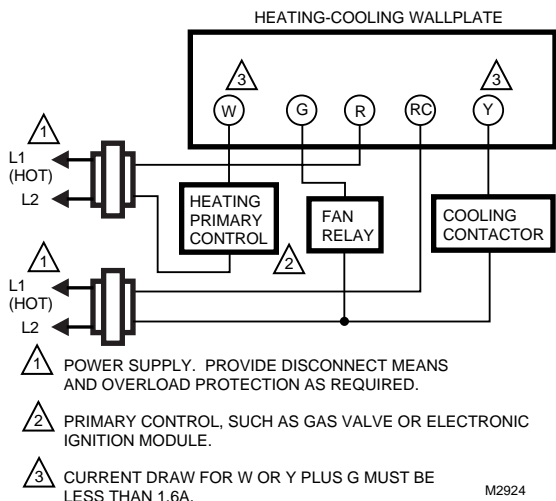

Fig. 12. T8602C,D heating/cooling circuit in a two-transformer (one for heating, one for cooling) system with gas heat and electric cooling, RC and R terminals.

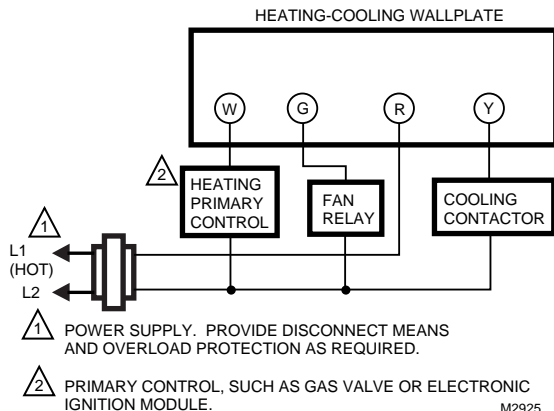

Fig. 13. T8602C,D heating/cooling circuit in a single transformer system with gas heat/electric cooling and electric furnace/electric cool. Controls fan in cooling only (typical multi-speed fan application).

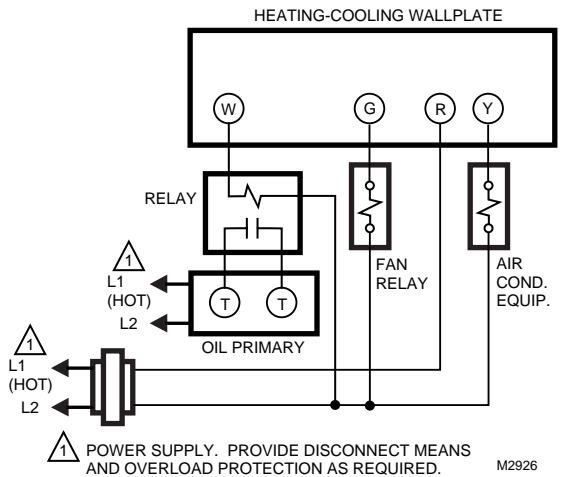

Fig. 14. T8602C,D heating/cooling circuit in an oil heating and electric cooling system. Heating transformer is in oil primary.

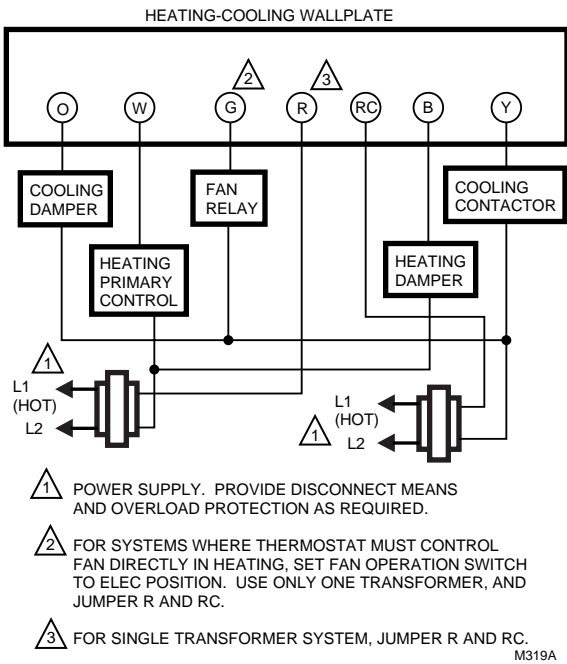
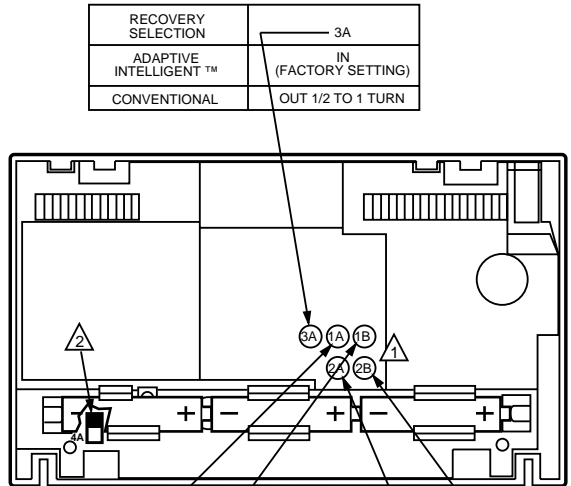

Fig. 15. T8602C heating/cooling circuit in a two-transformer system (gas heating and electric cooling). Includes O and B terminals for changeover control. See Table 2 to set fan operation switch.



SYSTEM	1A	1B	TIME/TEMP DISPLAY	2A	2B
GRAVITY AIR/WATER	OUT 1/2 TO 1 TURN	OUT 1/2 TO 1 TURN	24 HR	IN	—
HOT WATER	IN	OUT 1/2 TO 1 TURN	12 HR	OUT 1/2 TO 1 TURN	—
GAS/OIL WARM AIR	IN (FACTORY SETTING)	IN	°C	—	IN
ELECTRIC WARM AIR	OUT 1/2 TO 1 TURN	IN	°F	—	OUT 1/2 TO 1 TURN

Fig. 16. Cycle rate adjustment.

SETTING AND ADJUSTMENTS

Adjusting Cycle Rate

NOTE: MOST APPLICATIONS WILL NOT REQUIRE A CHANGE IN CYCLE RATE.

The room air temperature will vary slightly from the comfort temperature setting with the cycling of the furnace or air conditioner. The equipment cycles off and on as the room temperature approaches the setpoint.

The cycle rate of this thermostat is set for heating at six cycles per hour and for cooling at three cycles per hour as shipped from the factory. The cooling cycle rate cannot be adjusted. On all models, except the TS8602, the heating cycle rate can be adjusted by turning one or both cycle rate adjustment screws located on the back of the thermostat. See Fig. 16. The screws should only be backed out about one-half to one turn, or be turned in until tight.

Adaptive Intelligent Recovery™/ Conventional Recovery

The thermostat is factory-set for Adaptive Intelligent Recovery™, but may be converted to conventional recovery using screw 3A on the back of the thermostat as indicated in Fig. 16.

With Adaptive Intelligent Recovery™, the room will reach the comfort temperature at the exact time programmed into the thermostat. The control temperature will increase gradually, and turn the equipment on and off several times to reach the comfort temperature slowly and on time. There will be no wasted of energy associated with rapid temperature changes and temperature overshoot.

With conventional recovery, the start time should be programmed to be earlier than the desired comfort time. It may require some trial and error to arrive at the best starting time.

Setting Time/Temperature (Some Models)

The display readout may be converted between a 12 and 24 hour clock or °C and °F using screws 2A and 2B as indicated in Fig. 16.

Setting Fan Operation

Some T8602C models include a fan operation switch on the back of the thermostat on the lower left corner. See Fig. 15. See Table 2 to determine correct setting of fan operation switch.

CAUTION

The fan operation switch, which is available on some T8602C models, is factory set to the NON ELEC. position. If the system requires direct thermostat control of the fan in heat mode, the switch must be set to the ELEC. position. See Table 2.

Table 2. T8602C Fan Operation Switch Setting.

Fan Operation	Fan Operation Switch Setting (4A)	Comments
Fan controlled directly by thermostat in heat mode (typically electric furnaces).	Set to ELEC. position.	Use only one system transformer jumper R and RC.
Fan has independent control in heat mode (typically gas, oil, millivolt and some electric furnaces).	Set to NON ELEC. position	System may have one or two transformers; if one transformer, jumper R and RC.

Installing Batteries

Power is supplied for the thermostat by three AA alkaline batteries. Batteries are included with thermostat. Install batteries in back of thermostat as shown in Fig. 17. The display will flash 1:00 PM and room temperature.

When the batteries are going dead, the display will flash REPL BAT. If device has system switch, set to OFF. Remove the thermostat from the wall and install three new AA alkaline batteries. We recommend Energizer® batteries. Change batteries within approximately 30 seconds from the time the batteries are removed to prevent program loss and the necessity to reprogram.

IMPORTANT

The low battery warning will be displayed about two months before the batteries are dead. When the batteries are dead, the system will shut down. After batteries are replaced, thermostat will require reprogramming.

Mounting The Thermostat

Hang the thermostat on the tabs at the top of the base. See Fig. 18A. Swing down and press on the lower edge until the thermostat snaps into place. See Fig. 18B. Open the cover, and tighten the captive mounting screws. See Fig. 18C.

Setting Day and Time

Set the present day and time. When the thermostat is first turned on, the display will read 1:00 PM and the room temperature. It will go off for only a few seconds, then begin to flash on and off.

Press **SET PRESENT DAY/TIME**.

Press **TIME** **AHEAD** or **BACK** to set the current time.

Press **SET PRESENT DAY/TIME**.

Press **DAY** to set the current day. Each press of the DAY key advances the display one day.

If the display will not come on:

- Check mounting of thermostat to wallplate. If loose or misaligned, remove thermostat and reinstall on the wallplate, making sure it is firmly attached.
- Check to see that all the batteries are good and installed correctly.

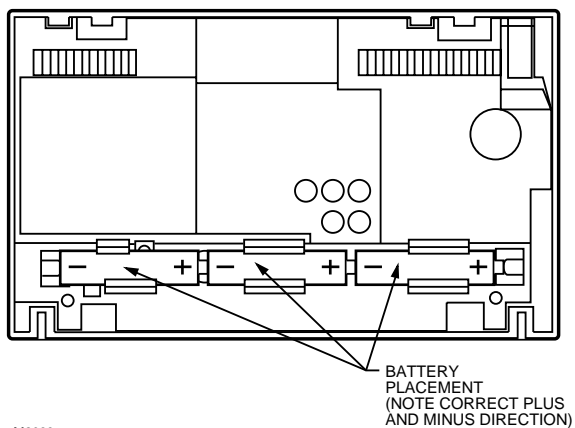

Fig. 17. Battery placement.

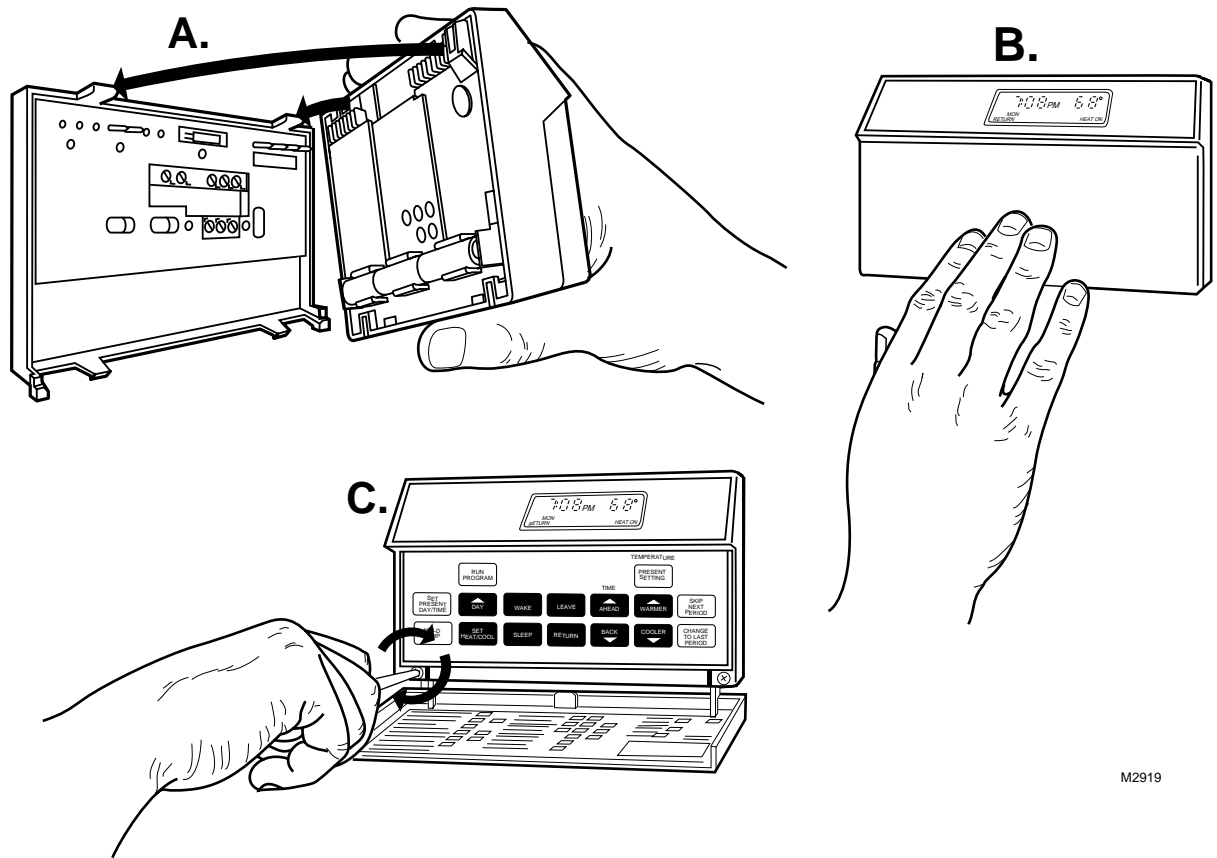

Fig. 18. Mounting thermostat on wallplate.

M2919

CHECKOUT

NOTE: On models without system or fan switch, disregard instructions about moving the switch.

Heating

Move the system switch to HEAT and the fan switch to AUTO. Press WARMER key until the setting is about 10°F (6°C) above room temperature. Heating should start and the fan should run (may be a short delay on forced air systems). Press COOLER key until the setting is about 10°F (6°C) below room temperature. The heating equipment should shut off.

Cooling

CAUTION

Do not operate cooling if outdoor temperature is below 50°F (10°C). Refer to manufacturer recommendations.

NOTE: When cooling setting is changed, thermostat will wait up to five minutes before turning on the air conditioner. This delay protects the compressor.

Move the system switch to COOL and the fan switch to AUTO. Press COOLER key until the setting is about 10°F (6°C) below room temperature. The cooling equipment and fan should start. Press the WARMER key until the setting is about 10°F (6°C) above room temperature. The cooling equipment and fan should stop.

NOTE: On an AUTO changeover thermostat (T8602D), the heating temperature must be set at least 3°F (2°C) below the cooling temperature, or the display will flash.

Fan

Move the system switch to OFF, and the fan switch to ON. The fan should run continuously. When the fan switch is in the AUTO position, the fan cycles with the heating or cooling system.

Installer Self-Test (Optional)

Perform the following test as a check of all thermostat functions. If thermostat does not respond as indicated, replace the thermostat.

- 1 Press AHEAD and BACK keys at the same time. While holding down the keys, all segments of the display should be on. See Fig. 19.
- 2 Set system switch to OFF, where applicable. Press AHEAD and BACK and PRESENT SETTING keys at the same time to enter self-test.
- 3 Press each key as listed below, and look for responses listed as key is held down and released.

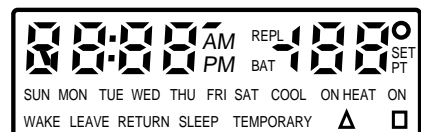

M410C

Fig. 19. All segments on display.

System Switch Position	Press This Key	Look For This Response	
		Key Down	Key Released
OFF		03	Blank
		07	Blank
		15	Blank
COOL or AUTO (with fan in AUTO)		15	Cooling, fan and SYSTEM LED on.
		15	Cooling, fan and SYSTEM LED off.
OFF		06	Blank
		02	Blank
		05	Blank
		04	Blank
		01	Blank
		00	Blank
	(Check Each position)		12
OFF		08	Blank
		13	Microprocessor mask no. and revision no.
		09	Blank
		14	Blank
HEAT ^m		14	Heating and SYSTEM LED on.
		14	Heating and SYSTEM LED off.
OFF		10	Blank
		11	Normal operating display

First Digit	Cycle Rate Setting (cph At 50% On Time)
0 or 1	1
2 or 3	3
4 or 5	9
6 or 7	6

Second Digit	Clock (Hr.)	Degrees	Recovery Setting
0	12	F	Conventional
1	12	C	Conventional
2	12	F	Adaptive Intelligent Recovery™
3	12	C	Adaptive Intelligent Recovery™
4	24	F	Conventional
5	24	C	Conventional
6	24	F	Adaptive Intelligent Recovery™
7	24	C	Adaptive Intelligent Recovery™

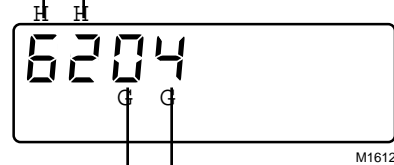

Third Digit	Thermostat Type No.	System Switch Position
0	C or D	OFF or AUTO
1	B	OFF
2	C or D	COOL
4	C or D	HEAT
5	A or B	HEAT or no switch

Fourth Digit	Thermostat Model	System Switch Position
0	TS8602A; T8602A,B or C	Any position.
1	T8602D	HEAT, OFF, or COOL
3	T8602D	AUTO
4	TS8602C; T8600, 01, or 03A,B or C	Any position.
5	T8600, 01, or 03D	HEAT, OFF, or COOL
7	T8600, 01, or 03D	AUTO

End Self-Test

^m For electric heat fan operation, the fan will operate with the heating system when the fan switch is in AUTO.

① HEAT displayed when system switch is in HEAT, COOL when in COOL, HEAT and COOL when in AUTO, neither when in OFF. Also, a four-digit code is displayed, with each digit explained as follows.

This equipment is a Class B digital apparatus which complies with Canadian Radio Interference Regulations, CRC c.1374.

Honeywell

Helping You Control Your World

Home and Building Control

Honeywell Inc.
1985 Douglas Drive North
Golden Valley, MN 55422

Home and Building Control

Honeywell Limited-Honeywell Limitée
740 Ellesmere Road
Scarborough, Ontario
M1P 2V9



QUALITY IS KEY