

SV9501/SV9502/SV9602P SmartValve™ System Control

TRADELINE®

INSTALLATION INSTRUCTIONS

APPLICATION

The Honeywell TRADELINE® SmartValve™ System Controls provide easy field replacement of a wide range of SV9500, SV9501, SV9502 and SV9602 SmartValve™ System models. Gas appliance manufacturers use these models in many types of gas fired heating appliances including central furnaces, residential boilers, rooftop furnaces, commercial cooking appliances, and unit heaters. These TRADELINE® controls provide intermittent pilot gas ignition sequencing, pilot flame sensing, and both pilot and main gas control functions in a single control. They are directly compatible with the Q3450 or Q3480 Intermittent Pilot burners used with the original controls on the appliance.

The TRADELINE® SV9501 and SV9502 SmartValve™ models are replacement controls only for the SV9500, SV9501, and SV9502 models noted in Table 5. Do not use these controls to replace other types of intermittent pilot or direct ignition controls. Do not use these controls to replace SmartValve™ models not listed in the Replacement table. The controls might fit, but the gas flow control functions might not be compatible with the appliance.

The TRADELINE® SV9602P SmartValve™ models are replacement controls only for the SV9500P, SV9501P, SV9502P, SV9600P and SV9601P models noted in Table 6. The SV9602P is a prepurge, step-opening model.

IMPORTANT

Do not use these controls to replace SmartValve™ models not listed in the replacement table.

Prepurge is nominally 30 seconds.

The step opening function provides a timed step outlet pressure at the start of each heating cycle to allow main burner ignition at reduced outlet pressure.

Reducer bushings are provided with the SV9602P model for adapting to smaller pipe sizes.

IMPORTANT

Carefully determine the full Honeywell model number of the existing control. Use Table 5 or Table 6 to make sure the replacement control model is suitable for replacing the original control. If the control is not suitable, obtain the correct TRADELINE® replacement control as shown in Table 5 or Table 6, or contact the appliance manufacturer for the proper replacement control.

INSTALLATION

When Installing this Product...

1. Read this instructions carefully. Failure to follow the instructions as written can damage the product or cause a hazardous situation.
2. Check the relevant chart and the ratings given in these instructions and on the specific model to make sure the product is suitable for the application.
3. Installer must be a trained, experienced, licensed (if required by local ordinance) technician.
4. Use these instructions to check product operation after completing installation.

IMPORTANT

Make sure the control being replaced is defective. See Figs. 13 through 16 for SV9500, SV9501, and SV9502 Sequence of Operation and Troubleshooting procedures.

Planning the Installation

WARNING

**Fire or Explosion Hazard.
Can cause severe injury, death or property damage.**

Follow these warnings exactly as written.

1. Plan the installation as outlined in this section.
2. Plan for frequent maintenance as described in the Maintenance section of this manual.

Intermittent pilot systems used on heating equipment in barns, greenhouses, and commercial properties, and on heating appliances such as commercial cookers,



agricultural equipment, and pool heaters make heavy demands on the controls. Special steps are recommended to prevent nuisance shutdowns and control failures due to frequent cycling, or severe environmental conditions such as exposure to moisture, corrosive chemicals, dust, or excessive heat. Following are the possible causes of shutdown and the preventative solutions.

Frequent Cycling

These controls are designed to cycle three to four times each hour during the heating season. Year around applications and applications with more frequent cycling rates can wear out controls more quickly than normal operation. Perform monthly system checks to make sure the system operates properly.

Water or Steam Cleaning

Replace any electronic control that gets wet. If the appliance is likely to be cleaned with water or steam, cover the control and wiring to protect them from water or steam flow. Mount the control high enough above the cabinet bottom to avoid getting it wet during cleaning procedures.

High Humidity or Dripping Water

Dripping water can cause the control to fail. Never install an appliance where water can drip on the control. High humidity around the control can cause the control to corrode and fail. If the appliance is located in a humid atmosphere, make sure the air circulation around the control is adequate to prevent water condensing on the control. Check the system regularly for signs of condensation and corrosion.

Corrosive Chemicals

Corrosive chemicals can erode the control, eventually causing a failure. If chemicals are used for routine cleaning, make sure they do not touch the control. Where chemicals are suspended in air, for example, in some industrial or agricultural applications, protect the control with an enclosure.

Dust or Grease Accumulation

Heavy accumulations of dust or grease can cause the control to malfunction. Where dust or grease are problems, cover the control to limit contamination.

Heat

Excessively high (above 175°F [79°C]) temperatures can damage the control. Make sure the ambient temperature at the control does not exceed the control rating. If the appliance operates at very high temperatures, use insulation, shielding and proper air circulation as necessary to protect the control. The appliance manufacturer should provide proper insulation or shielding. Make sure there is proper air circulation when installing the appliance.

Installation

WARNING

Fire or Explosion Hazard.
Can cause severe injury, death or property damage.

Follow these warnings exactly as written.

1. Disconnect the power supply before wiring to prevent electrical shock and equipment damage.
2. Turn of the gas supply at the appliance service valve before starting installation to avoid dangerous accumulation of fuel gas.
3. Perform gas leak test after completing installation.
4. Do not bend pilot tubing at ignition system control or pilot burner after tightening the compression fitting. Bending can cause gas leakage at the connection.
5. Always install a sediment trap in the gas supply line to prevent contamination of the ignition system.

WARNING

Fire or Explosion Hazard.
Can cause severe injury, death or property damage.

Follow this warning exactly as written.

•Always change the main and pilot burner orifices when converting between LP and natural gas. Follow appliance manufacturer specifications and instructions.

CAUTION

Equipment Damage Hazard.
Improper device replacement will damage the equipment.

The SV9501, SV9502, and SV9602P provide direct replacement only as shown in Table 5 or Table 6 of this manual. Use the Y8610 to convert standing pilot systems to electronic ignition systems.

CAUTION

Equipment Damage Hazard.
Can Burn Out Heat Anticipator in Thermostat.

1. Never apply a jumper across or short the terminals in the SV9501, SV9502, or SV9602P connectors or appliance wiring harnesses.
2. Never short the electric fan timer (EFT) output. Shorting the output can damage the EFT drive circuitry.

IMPORTANT

These ignition system controls are shipped with protective seals over inlet and outlet tappings. Do not remove seals until ready to connect piping.

Follow the appliance manufacturer's instructions if available. Otherwise, use these instructions as a guide.

Ignition system controls are set at the factory for natural or LP gas. Do not attempt to use an ignition control made for LP gas on a natural gas system. Do not attempt to use an ignition control made for natural gas on an LP gas system.

Ignition system controls with standard opening regulators (SV9501M and SV9502M) or slow opening regulators (SV9501H and SV9502H) can be converted between natural gas and LP gas.

Ignition system controls with step opening regulators (P suffix) cannot be converted between gases.

Selecting the Valve

Make sure when replacing any SmartValve™ that you know what valve is going in and what valve is coming out. The SV9501 and SV9502 look slightly different from the SV9500. The SV9500 features an ON/OFF control knob, as shown in Fig. 1. The SV9501, SV9502 and SV9602 have an ON/OFF switch, as shown in Fig. 2. The SV9501 and SV9502 have a connector located at the top of the valve instead of on the front.

The SV9501, SV9502, and SV9602 have identical valve body features and use the same connectors.

NOTE: The SV9602P does not have a flange mounting capability.

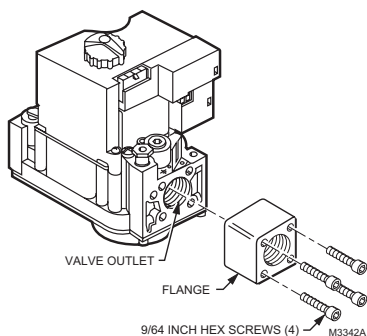

Fig. 1. Front view of SV9500. Notice the ON/OFF control knob.

Location

Mount the SV9501, SV9502 or SV9602 on the gas manifold in the appliance.

Use of Pipe Adapters

In some field service applications, space limitations make it difficult or impossible to thread the gas control onto the gas supply line. This problem can be resolved for many

installations by using a pipe adapter. Install the pipe adapter on the end of the supply line in place of the gas control by following the same precautions and instructions that are used for installing the gas control. After the pipe adapter is installed, attach the gas control to the adapter.

NOTE: Using a pipe adapter increases the overall length of the gas control.

Install Pipe Adapter to Gas Control

Install adapter to gas control as follows:

Bushings

1. Remove seal over gas control inlet or outlet.
2. Apply moderate amount of good quality pipe compound to bushing, leaving two end threads bare.
3. Insert bushing into gas control and carefully thread pipe into the bushing until tight.

Installing Flange Adapters to Control (If Required)

Mount any necessary adapters as follows:

Flanges

1. Choose the correct flange for the application.
2. Remove the seal over the ignition system control or outlet.
3. Make sure the O-ring is fitted in the flange groove. If the O-ring is not attached or is missing, do not use the flange.
4. With the O-ring facing the ignition system control, align the screw holes on the ignition system control with the holes in the flange.
5. Insert the screws provided with the flange.
6. Tighten the screws firmly but do not over tighten

Installing Piping to Control

IMPORTANT

Do not use Teflon® tape.

All piping must comply with local codes or ordinances or with the National Fuel Gas Code (ANSI Z223.1 NFPA No. 54), whichever applies. Tubing installation must comply with approved standards and practices.

1. Use new, properly reamed pipe that has no chips.
2. Make sure the ends are square, deburred, and clean.
3. Make sure all tubing bends are smooth and without deformation.
4. Get a tube-to-pipe coupling if necessary.
5. Run pipe or tubing to the ignition system control.
6. Install a sediment trap in the supply line to the ignition system control as shown in Fig. 3.

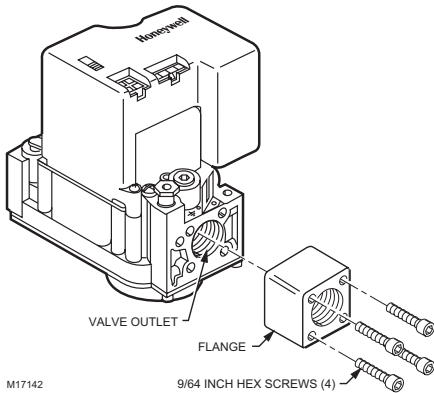

Fig. 2. Front view of SV9501 or SV9502. Notice the connectors and the ON/OFF control switch.

Installing the Control

This ignition system can be mounted from 0 to 90 degrees in any direction including vertically from the upright position of the ignition system control switch.

IMPORTANT

Make sure to mount the replacement control in the same location and orientation as the original control.

1. Mount the control so the gas flow is in the direction of the arrow on the bottom of the ignition system control, as shown in Fig. 4.
2. Apply a moderate amount of good quality pipe compound to the pipe, leaving the two end threads bare, as shown in Fig. 5. For LP controls make sure to use an LP resistant pipe compound.
3. Remove the seals over the ignition system control inlet and outlet if necessary.
4. Thread the pipe the amount shown in Table 1. Do not thread the pipe too far, because this could cause valve distortion or malfunction.
5. Using a wrench on the square ends of the ignition system control, connect the pipe to the ignition system control inlet and outlet.

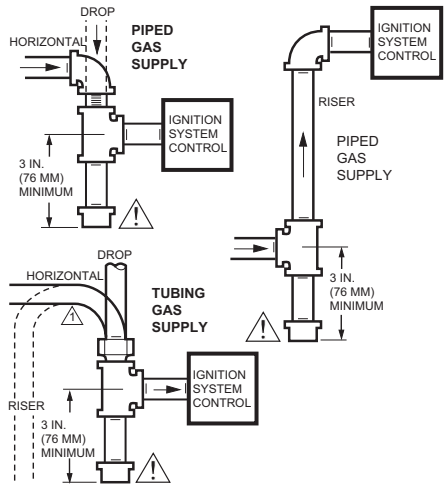

⚠ ALL BENDS IN METALLIC TUBING MUST BE SMOOTH.

CAUTION

Gas Leakage Hazard.
Failure to follow precautions can result in a gas-filled work area. Shut off the main gas supply before removing end cap. Test for gas leakage when installation is complete. M3343C

Fig. 3. Sediment trap installation.

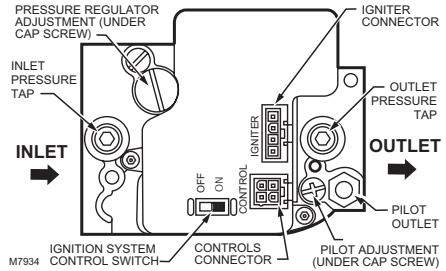

Fig. 4. Mount so gas flows in the direction of the arrows.

NOTE: If the control has a flange, place the wrench on the flange instead of on the ignition system control, as shown in Fig. 6.

Table 1. Threading the Pipe.

Pipe Size	Thread Pipe this Amount	Maximum Depth Pipe can be Inserted into Control
3/8 in.	9/16 in.	3/8 in.
1/2 in.	3/4 in.	1/2 in.
3/4 in.	13/16 in.	3/4 in.

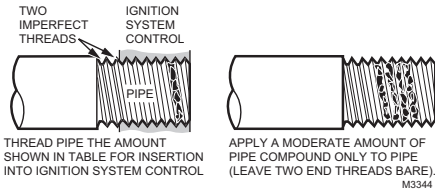

Fig. 5. Use a moderate amount of pipe compound.

Connecting the Pilot Gas Tubing

NOTE:

1. The pilot tubing provides the SmartValve™ system's flame sense current path. Make sure the connections are clean and tight.
 2. Do not make sharp bends or deform the tubing. Do not bend tubing at the ignition system control after the compression nut is tightened, because this can cause gas leakage.
1. Cut the tubing to the desired length.
 2. Bend the tubing as necessary for routing to the pilot burner.
 3. Square off and debur the end of the tubing.
 4. Unscrew the brass compression fitting from the pilot outlet.

5. Slip the fitting over the tubing and out of the way.
6. Push the tubing into the pilot gas outlet.
7. Tap the outlet end of the control.
8. Remove and discard the old fitting.
9. While holding tubing all the way in, slide the new fitting (included with the new SmartValve) into place and begin thread until finger tight as shown in Fig. 7.
10. Tighten fitting one more full turn with the wrench. Do not overtighten.
11. Connect the other end of the tubing to the pilot burner as described in the instructions supplied with Q3450 or Q3480 pilot hardware.

Wiring

Follow the wiring instructions supplied by the appliance manufacturer if available. Otherwise, use the following general instructions.

NOTE:

1. In most cases, connect the wiring by plugging the appliance wiring harness connector into the SmartValve™. Use the supplied extension harness if necessary.
2. Where the general instructions are different from the appliance manufacturer's instructions, use the appliance manufacturer's instructions.

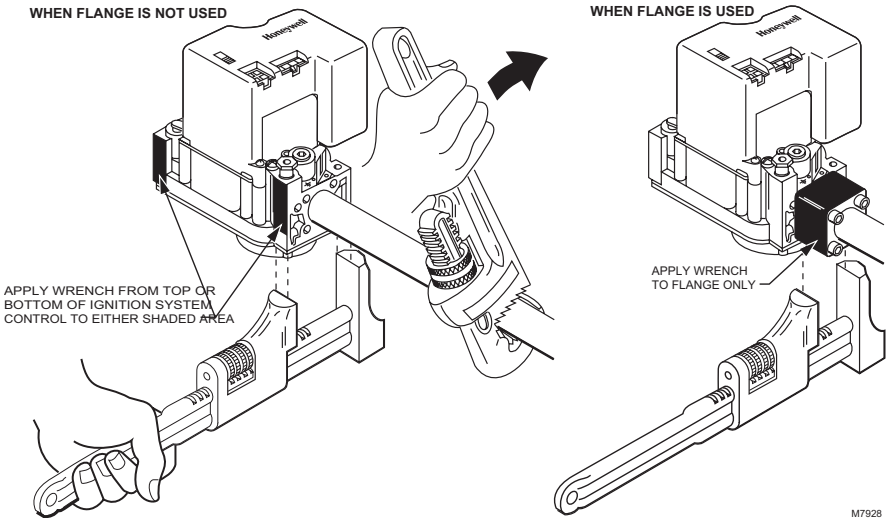

Fig. 6. Proper use of wrench on ignition system control with and without flanges.

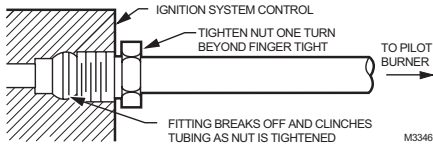

Fig. 7. Tighten new fitting and nut. Always use a new compression fitting.

CAUTION

Equipment Damage Hazard.
Electrostatic discharge can short equipment circuitry.
Disconnect the power supply before making wiring connections.

IMPORTANT

All wiring must comply with applicable electrical codes and ordinances.

NOTE: If the wiring harness is damaged, contact the equipment manufacturer for a replacement harness.

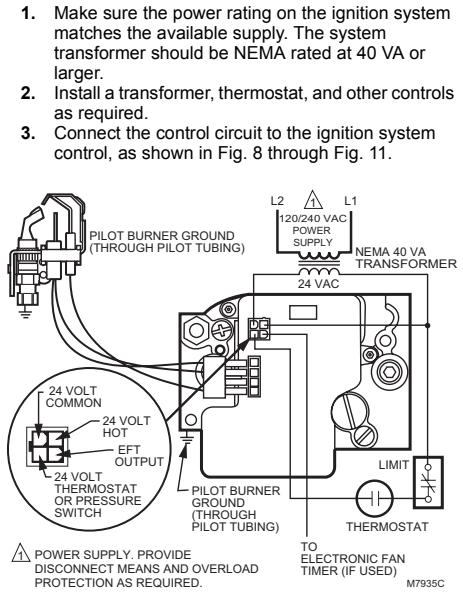

Fig. 8. SV9501/SV9502/SV9602P basic wiring diagram.

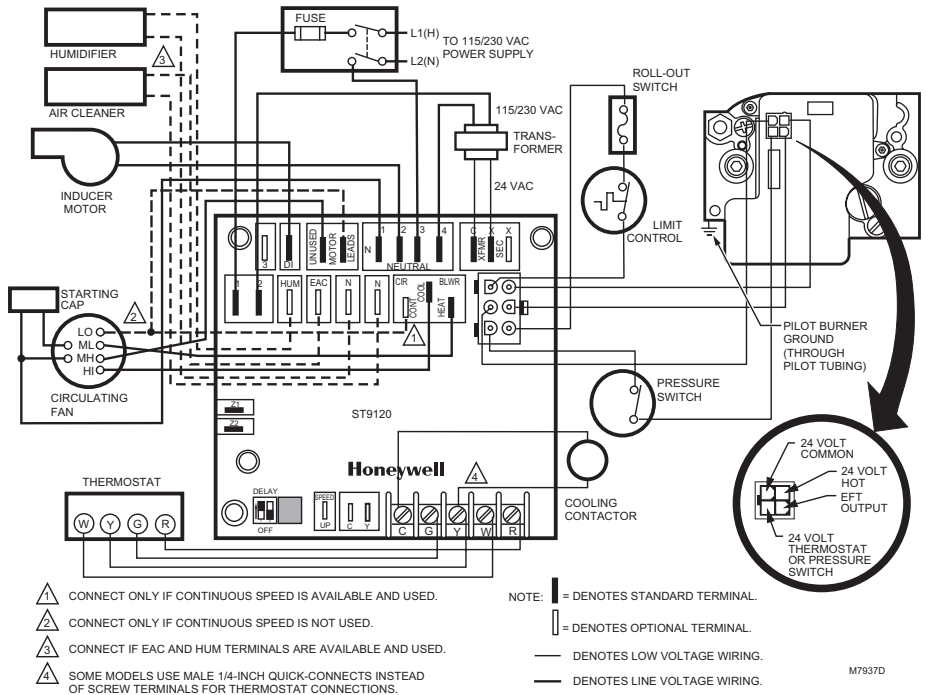

Fig. 9. SV9501/SV9502/SV9602P typical wiring connections in fan assisted warm air furnace with ST9120 Electric Fan Timer.

STARTUP AND CHECKOUT

▲ WARNING

Fire or Explosion Hazard.
Can cause severe injury, death or property damage.
 Do not force the ignition switch on the appliance.
 Do not use tools to move the ignition switch. If the switch does not move by hand, a qualified service technician must replace the control.

Ignition System Control Switch Settings

NOTE: The control switch only controls gas flow. It does not control the igniter circuit.

Ignition system control switch settings are:

OFF

Prevents pilot and main gas flow through the ignition system control. The rest of the ignition sequence occurs normally.

ON

Allows gas to flow through the control valve. The thermostat controls the gas flow to the pilot and main burners.

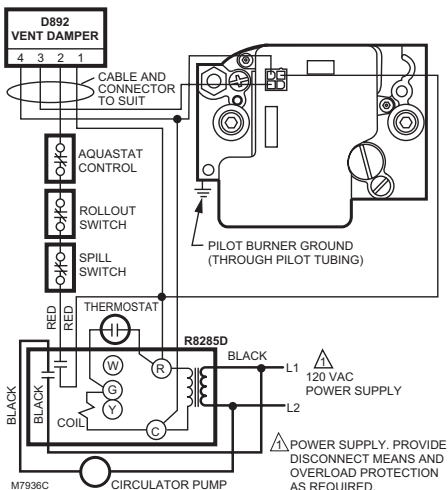

Fig. 10. SV9501/SV9502/SV9602P typical wiring diagram in atmospheric boiler.

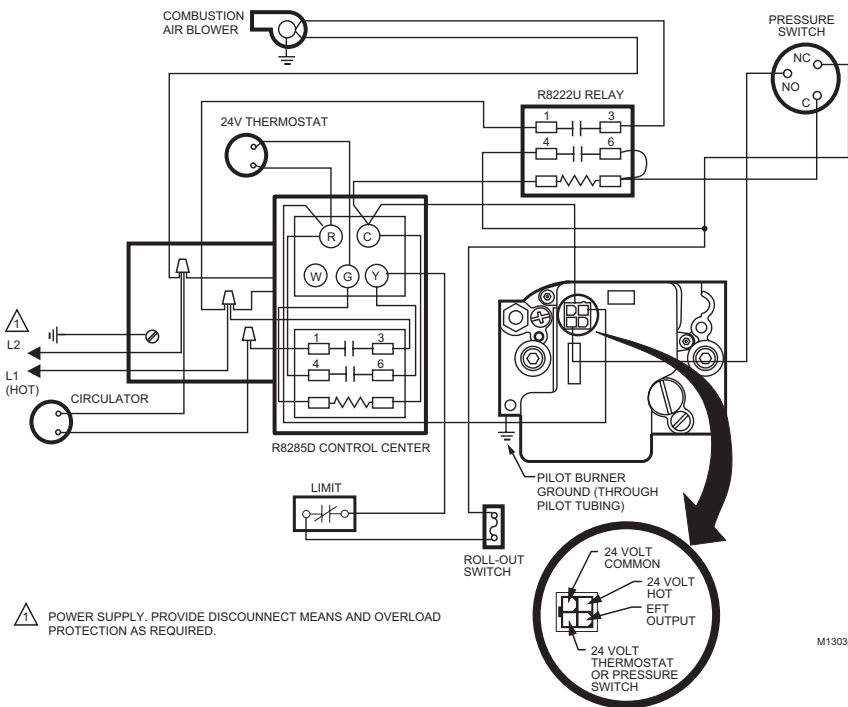

Fig. 11. SV9501/SV9502/SV9602P typical wiring diagram in induced draft boiler application.

Turning on the System

Push the switch to the ON position.

Turning on the Main Burner

Follow the instructions provided by the appliance manufacturer or turn up the thermostat to call for heat. If the main burner does not light, refer to the troubleshooting table.

Perform Gas Leak Test

⚠ WARNING

Fire or Explosion Hazard.
Can cause severe injury, death or property damage.

1. Check for gas leaks with soap and water solution every time work is done on a gas system.
2. Stand clear of the main burner when lighting it to prevent injury from hidden leaks that could cause flashback.

Gas Leak Test

1. Paint the pipe connections located upstream from the ignition system control with a rich soap and water solution.
Bubbles indicate a gas leak.
2. If a leak is detected, tighten the pipe connections.
3. Repeat steps 1 and 2 until no leaks are detected in that area.
4. Light the main burner.
5. With the main burner in operation, paint the pipe joints, adapters, and control inlet and outlet with a rich soap and water solution.
6. If a leak is detected, tighten the adapter screws, joints, and pipe connections.
7. Repeat steps 5 and 6 until no leaks are detected.
8. Replace the part with the same model number if any leak cannot be stopped.

Adjust the Pilot Flame

The pilot flame should envelop 3/8 in. to 1/2 in. (10 cm to 13 cm) of the tip of the flame rod, as shown in Fig. 12.

1. Remove the pilot adjustment cover screw.
2. Turn the inner adjustment screw clockwise to decrease or counterclockwise to increase the pilot flame.
3. After adjusting the flame, replace and tighten firmly the cover screw to prevent gas leakage.

NOTE: Controls are provided with adjustment screws set at the maximum pilot flow position.

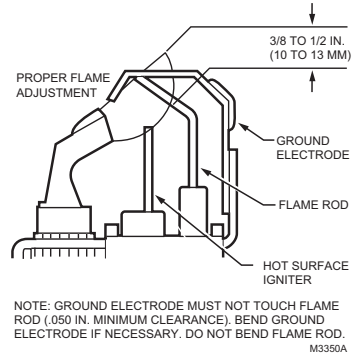

Fig. 12. Proper flame adjustment.

Check and Adjust Gas Input and Burner Ignition

IMPORTANT

- Many replacement valves require outlet pressure adjustment.
- Do not exceed the input rating stamped on the appliance nameplate.
- Do not exceed the manufacturer's recommended burner orifice pressure for size of orifice used.
- Make sure the primary air supply to the main burner is properly adjusted for complete combustion.
- Follow the appliance manufacturer's instructions.

If Checking Gas Input by Clocking Gas Meter

1. Make sure there is no gas flow through the meter other than the flow to be checked.
2. Other appliances supplied by this meter must remain off with their pilots extinguished or their gas consumption must be deducted from the meter reading.
3. Convert flow rate to Btuh as described in Gas Controls Handbook, form 70-2602, and compare the result to the Btuh input rating on the appliance nameplate.

If Checking Gas Input with Manometer

1. Make sure gas supply is shut off at the manual valve in the natural gas piping to an appliance or at the tank for LP gas before removing the inlet pressure plug.
2. Make sure the ignition system control is in OFF position when removing the gauge and replacing the plug.
3. Make sure the ignition system control is in OFF position before removing the outlet pressure tap plug and connecting the manometer (pressure gauge).
4. Shut off the gas supply before disconnecting the manometer and replacing the plug.
5. Repeat the gas leak test at the plug with the main burner operating.

Standard Pressure Regulator (M Models), Slow Open (H models), Step Open (P Models)

1. Check the full rate manifold pressure listed on the appliance nameplate. The ignition system control outlet pressure must match the full rate pressure listed on the nameplate. Adjust the pressure if they do not match.

NOTE: Slow opening (H models) and step opening (P models) may take several seconds to reach full flow rate. M models will take 2 to 3 seconds to reach full flow rate.

2. With the main burner ON, check the ignition system control flow rate using the meter clocking method, or check the pressure using a manometer connected to the outlet pressure tap on the ignition system control.
3. Adjust the pressure regulator to match the appliance rating if necessary. See Tables 2 and 3 for factory set nominal outlet pressure and adjustment range.
 - a. Remove the pressure regulator adjustment cap screw.
 - b. Using a screwdriver, turn the inner adjustment screw clockwise to increase or counter clockwise to decrease gas pressure to the burner.
 - c. Replace the cap screw and tighten it firmly to prevent gas leakage.
4. If the desired outlet pressure or flow rate cannot be achieved by adjusting the ignition system control, check the ignition system control inlet pressure using a manometer at the ignition system control inlet pressure tap.

5. If the inlet pressure is in the factory specified nominal range, as shown in Tables 2 and 3, replace the ignition system control. Otherwise, take the necessary steps to provide proper gas pressure to the control.

NOTE: If the burner firing rate is above the maximum capacity as shown in Table 4, it might not be possible to deliver the desired outlet pressure. This is an application issue, not a control failure. Take whatever steps are necessary to correct the situation.

MAINTENANCE

WARNING

Fire or Explosion Hazard.

Can cause severe injury, death or property damage.

Do not attempt to take the control apart or clean it. Improper cleaning or reassembly may cause gas leakage.

Regular preventive maintenance is important in applications that place a heavy load on system controls. This includes applications in commercial cooking, agricultural, and industrial industries where these conditions often exist:

- Heavy cycling. In commercial cooking, the operation, the equipment operates 100,000 to 200,000 cycles per year. This can wear out a gas control in one to two years.
- Exposure to water, dirt, chemicals, and heat can damage the gas control and shut down the control system.

Table 2. SV9501/SV9502/SV9602P Pressure Regulator Specification Pressures.

Model Type	Type of Gas	Nominal Inlet Pressure Range		Factory Set Nominal Outlet Pressure				Setting Range			
				Step		Full Rate		Step		Full Rate	
		in. wc	kPa	in. wc	kPa	in. wc	kPa	in. wc	kPa	in. wc	kPa
Standard, Slow	NAT	5.0-7.0	1.2-1.7	—	—	3.5	0.9	—	—	3-5	0.7-1.2
	LP	12.0-14.0	2.9-3.9	—	—	10.0	2.5	—	—	8-12	2-3
Step	NAT	5.0-7.0	1.2-1.7	0.9	0.2	3.5	0.9	None	None	3-5	0.7-1.2
	LP	12.0-14.0	2.9-3.9	2.2	0.2	10.0	2.5	None	None	8-12	2.0-3.0

Table 3. Capacity of SV9501/SV9502/SV9602P.

Model	Size (Inlet x Outlet) (in.)	Capacity (at 1 inch wc pressure drop)	Minimum Regulated Capacity	Maximum Regulated Capacity
SV9501/SV9502	1/2 x 1/2	150 ft ³ /hr (3.7m ³ /hr)	20 ft ³ /hr (0.6m ³ /hr)	200 ft ³ /hr 95.7m ³ /hr
SV9602P	3/4 x 3/4	300 ft ³ /hr (8.5m ³ /hr)	30 ft ³ /hr (0.8 m ³ /hr)	415 ft ³ /hr (11.8m ³ /hr)

The maintenance program should include regular checkout of the control as described in the Startup and Checkout section, and the control system as described in the application manufacturer's literature.

Maintenance frequency must be determined individually for each application. Some considerations follow:

- Cycling frequency. Appliances that cycle 20,000 times annually should be checked each month.

- Intermittent use. Appliances that are used seasonally should be checked before shutdown and before each use.
 - Consequence of unexpected shutdown. Where the cost of an unexpected shutdown would be high, check the system frequently.
 - Dusty, wet, or corrosive environment. Since these environments can cause the gas control to deteriorate more rapidly, check the system frequently.
- Replace the system if any of the following conditions occur:

- The system does not perform properly at checkout or troubleshooting.
- The gas control switch is difficult to move.
- The gas control has operated for more than 200,000 cycles.
- The control is wet or shows signs of moisture.

INSTRUCTIONS TO THE HOMEOWNER

WARNING

Fire or Explosion Hazard.
Can cause severe injury, death or property damage.

Follow these warnings exactly as written.

1. Do not light the pilot flame manually. Pilot flame lights automatically.
2. Smell around the appliance for gas. Be sure to smell next to the floor, because LP gas is heavier than air.
3. *If you smell gas:*
 - Turn off the gas supply at the appliance service valve. For LP gas systems, turn off the gas supply at the gas tank.
 - Do not light any appliances in the house.
 - Do not touch any electrical switches.
 - Do not use the phone.
 - Leave the building, and go to a neighbor's phone to call your gas supplier.
 - If you cannot reach your gas supplier, call the fire department.
4. Do not force or use tools to move the ignition system control switch. If the switch does not operate by hand, the ignition system control must be replaced by a qualified, licensed (if required) service technician. Force or attempted repair can result in fire or explosion.
5. Replace the ignition system control if it shows any evidence of physical damage, tampering, bent terminals, missing or broken parts, stripped threads, or exposure to excessive heat.

SERVICE

WARNING

Fire or Explosion Hazard.
Can cause severe injury, death or property damage.

Do not disassemble the ignition system control. It contains no replaceable parts. Attempted disassembly or repair can damage the ignition system control.

CAUTION

Equipment Damage Hazard.
Can burn out heat anticipator in thermostat.

1. Do not apply a jumper across or short the control terminals. Doing so may burn out the heat anticipator in the thermostat or damage the system transformer.
2. Make sure to check operation after service.

Sequence of Operation

1. Make sure the ignition system control switch is in the ON position.
2. Follow the sequence of operation shown in Fig. 14.

If the Main Burner Does Not Come On with Call for Heat

1. Make sure the ignition system control switch is in the ON position.
2. Adjust the thermostat several degrees above room temperature.
3. Make sure the appliance is receiving power. See Fig. 15 or 16, as applicable.

IMPORTANT

Follow the warnings in the Instructions to the Homeowner section!

Follow the operating instructions provided by the manufacturer of your heating appliance. The following information assists in a typical ignition system control application, but the specific controls used and the procedures outlined by the manufacturer of your appliance can be different. Such appliances require special instructions.

Turning the Appliance ON

The pilot flame is lit automatically. If the appliance does not turn on when the thermostat is set several degrees above room temperature, follow these instructions:

1. Set the thermostat to its lowest setting to reset the safety control.
2. Disconnect all electric power to the appliance.
3. Remove the ignition system control access panel.
4. Move the ignition system control switch to OFF.
5. Wait a minimum of five minutes to clear out any unburned gas. If you smell gas, follow step 3 in the warning. Otherwise continue to the next step.
6. Move the ignition system control switch to ON.
7. Replace the ignition system control access panel.
8. Reconnect the power to the appliance.
9. Set the thermostat to the desired setting.

10. If the appliance still does not turn on, set the ignition system control switch to OFF and contact a qualified, licensed (if required) service technician.

NOTE: The SV9502 and SV9602P have an approximately 30-second prepurge delay before start of Ignition Trial. Be sure to wait for prepurge to be completed.

Turning the Appliance OFF

Vacation Shutdown

Set the thermostat to the desired temperature while you are away.

Complete Shutdown

1. Turn off the power to the appliance.
2. Move the ignition system control switch to OFF without forcing it.

The appliance shuts off completely.

Follow the instructions in Instructions to the Homeowner to resume normal operation.

OPERATING SEQUENCE

The following flowcharts describes the basic operating sequence for the SV9500 and SV9501/SV9502/SV9602P controls. This information is designed to assist field technicians to analyze normal appliance operation.

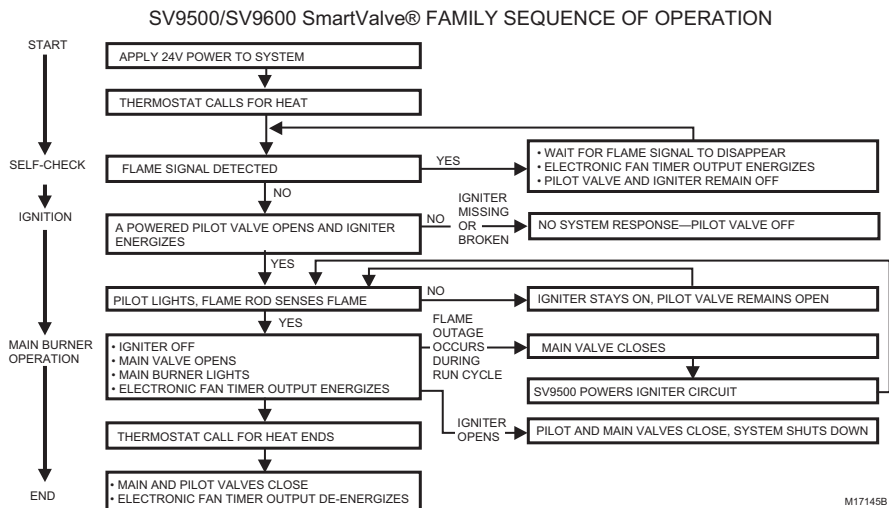
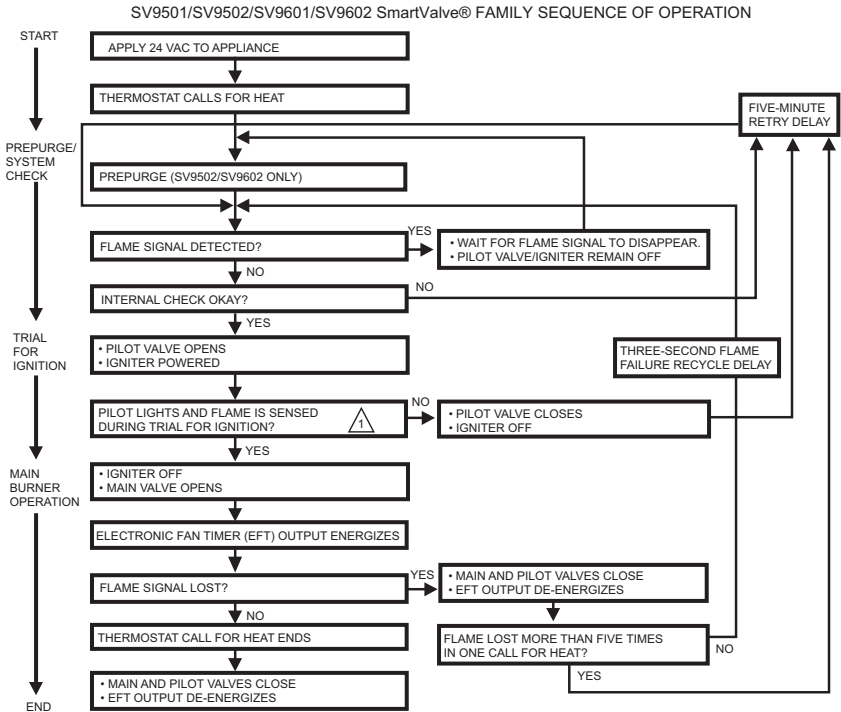

Fig. 13. SV950/SV9600 SmartValve™ System Sequence of Operation.



⚠ IGNITER WILL TURN OFF ABOUT 30 SECONDS INTO THE TRIAL FOR IGNITION IF THE PILOT FLAME HAS NOT LIT. IT WILL TURN BACK ON FOR THE FINAL 30 SECONDS OF THE 90 SECOND TRIAL FOR IGNITION. THE PILOT VALVE WILL BE ENERGIZED DURING THE ENTIRE TRIAL FOR IGNITION. THIS IS NORMAL OPERATION FOR THIS GAS IGNITION SYSTEM.

M17144A

Fig. 14. SV9501/SV9502/SV9602 SmartValve™ Sequence of Operation.

TROUBLESHOOTING

The attached flowcharts provide specific troubleshooting information for the SV9500, SV9501 and SV9502/SV9600, SV9601, SV9602 products. These charts assist the field technician to analyze appliance operation difficulties.

⚠ CAUTION

Equipment Damage.

Can damage connectors on wiring harness.

1. Proper troubleshooting requires measurement of voltage and resistance with a volt/ohm meter.
2. Use proper size probes and appropriate testing techniques to assure good test information without damaging the control terminals, connectors or wiring harness.

Use the following basic troubleshooting procedure.

1. Review this information carefully prior to going to the job site.
2. Identify the specific SmartValve™ (SV9500, SV9501, SV9502, SV9600, SV9601, SV9602).
3. Make sure the Q3450/Q3480 HSI element is good.

4. Disconnect the HSI element from the SmartValve™.
5. Using a multimeter, measure the HSI element room temperature resistance. It should be less than 10 ohms.
6. Make sure the SmartValve™ switch (knob if SV9500/SV9600) is in the ON position (unless directed otherwise in the Troubleshooting flowchart).
7. Make sure the appliance call for heat function provides proper inputs to the SmartValve™ through the 2X2 power connector. (Measure with voltmeter on the ac scale.)
8. Follow the Operating Sequence and Troubleshooting flow charts as shown in Fig. 13 and Fig. 15 for the installed SmartValve™ SV9500/SV9600 to make sure replacement is necessary.
9. Follow the Operating Sequence and Troubleshooting flow chart in Fig.14 and Fig. 16 for the replacement SV9501/SV9502/SV9601/SV9602 SmartValve™.

NOTE: The HSI element action for SV9501/SV9502/SV9601/SV9602 is different from the HSI element action for SV9500/SV9600. For SV9500/SV9600, the element is on continuously during a call for heat until shortly

after the pilot flame is detected, the main valve energizes and the element turns off. For SV9501/SV9502/SV9601/SV9602, the call for heat generates a 90-second "trial for pilot

ignition." If no pilot flame is sensed, it retries after a five minute delay. The element cycles off and back on once during the trial for pilot ignition.

SV9500SV9600 SmartValve™ TROUBLESHOOTING SEQUENCE

NOTE: BEFORE TROUBLESHOOTING, BECOME FAMILIAR WITH THE STARTUP AND CHECKOUT PROCEDURE. ALSO CHECK PILOT BURNER ELEMENT FOR RESISTANCE LESS THAN 10 OHMS WITH ELEMENT AT ROOM TEMPERATURE.

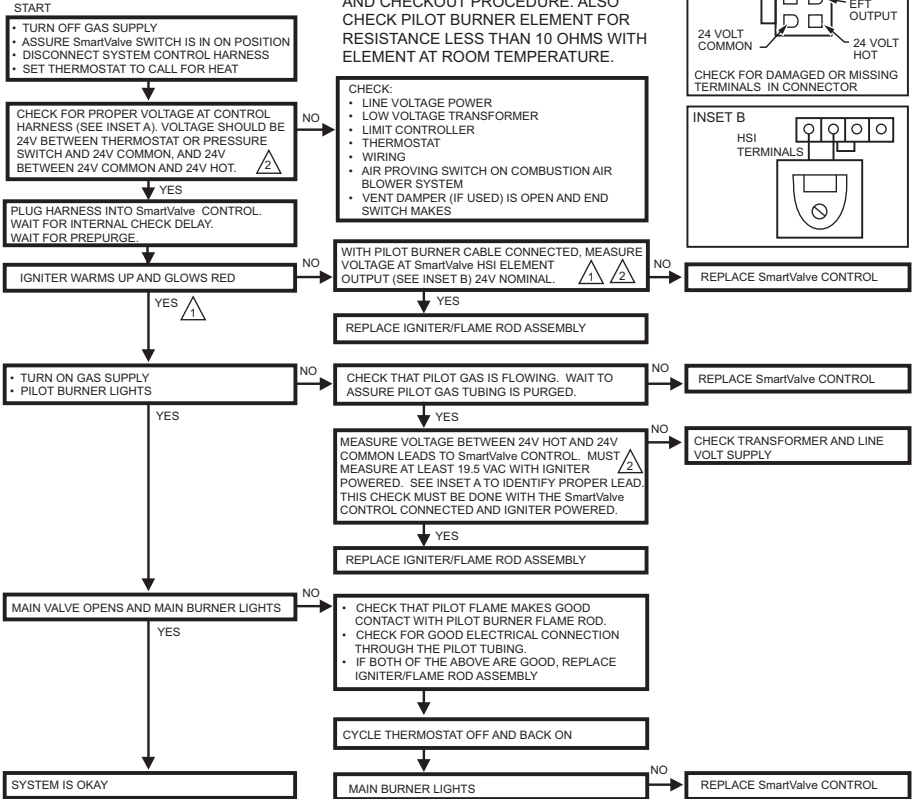
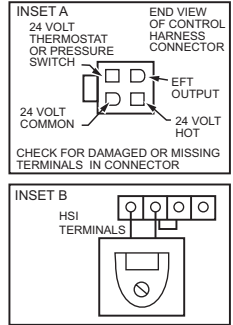

⚠️ IGNITER WILL STAY ENERGIZED AS LONG AS APPLIANCE CALL FOR HEAT IS IN PLACE.

⚠️ WHEN MEASURING VOLTAGE AT CONNECTIONS, USE CARE TO ASSURE TERMINALS ARE NOT DAMAGED.

M17146A

Fig. 15. SV9500/SV9600 troubleshooting guide.

SV9501/SV9502/SV9601/SV9602 SmartValve™ TROUBLESHOOTING SEQUENCE

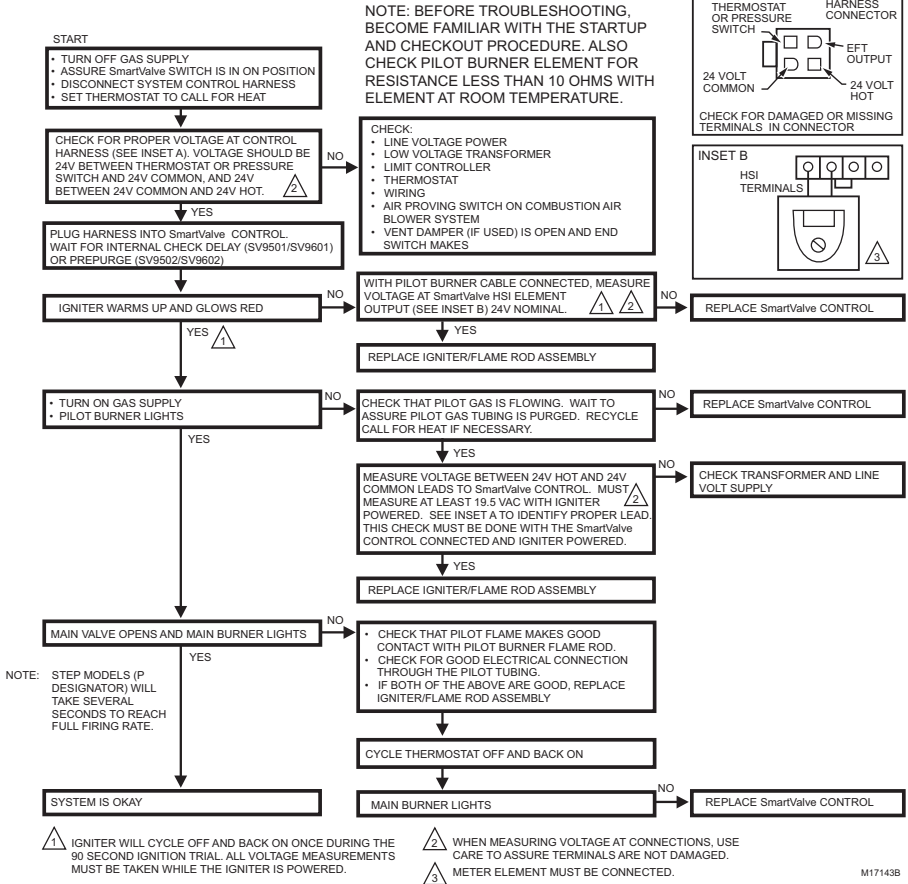

Fig. 16. SV9501/SV9502/SV9601/SV9602 SmartValve™ Troubleshooting Sequence.

Table 4. Replacement chart for SV9500, SV9501, and SV9502.

Order Number	Inlet/Outlet Size	Pressure Regulator Setting		Type of Opening	Prepurge Time	Type of Gas	Replaces
		in. wc	kPa				
SV9502H2522	1/2 in. x 1/2 in.	3.5	0.87	Slow	15 sec.	Natural	SV9500H2609 ^{a,e} SV9500H2617 ^{a,e} SV9500H2724 ^e SV9500H3607 ^{a,d,e} SV9500H3615 ^{b,d,e} SV9501H2409 ^{a,e} SV9501H2417 ^e SV9501H2425 ^{b,e} SV9501H3415 ^{a,d,e} SV9501H3423 ^{b,d,e} SV9502H1706 SV9502H2522 SV9502H2704
SV9501M2528							Standard
SV9501M8129		3.4	Fast	SV9500M8600 SV9500M8618 ^b SV9500M8659 ^b SV9500M8667 SV9500M8808 SV9501M8103 SV9501M8111 ^b SV9501M8129			

^a Regulator setting in replacement control differs from original. Adjust to rated pressure as necessary for optimum performance.

^b Shipped by Honeywell as LP gas only; may have been converted to natural gas. Use Natural to LP gas conversion kit (included) if necessary. Follow instructions in conversion kit.

^c Requires vent fitting (part no. 392877, order separately).

^d Requires 3/4 in. straight flange (part no. 393690-14, order separately).

^e Replacement control includes prepurge time not included with original control.

Table 5. SV9602 Replacement Chart.

Order Number	Inlet/Outlet Size	Pressure Regulator Setting		Type of Opening	Purge Time	Type of Gas	Replaces	
		in. wc	kPa					
SV9602P4816	3/4 in. x 3/4 in.	3.5	0.7	Step	30 Sec. 30 sec.	Natural	SV9500P2600 ^{b,c} SV9500P2634 ^{b,c} SV9500P2642 ^{a,b,c} SV9501P2004 ^{b,c} SV9501P2053 ^{a,b,c} SV9502P2101 ^b SV9600P4612 ^c SV9600P4620 ^{a,c} SV9600P4646 ^c SV9601P4107 ^c SV9602P4105 SV9602P4816	
SV9602P4824			2.5				SV9501P2087 ^{b,c,d} SV9502P2127 ^{b,d} SV9601P4172 ^{c,d} SV9602P4121 ^d SV9602P4824	
SV9602P4832		10	2.5				LP	SV9500P2618 ^{b,c} SV9500P2659 ^{b,c} SV9501P2020 ^{b,c,e} SV9501P2046 ^{b,c} SV9502P2119 ^b SV9502P2135 ^{b,e} SV9601P4149 ^c SV9601P4164 ^{d,e} SV9602P4113 SV9602P4139, ^e SV9602P4832
SV9602P4840		1.4	SV9600P4604 ^c SV9600P4638 ^c SV9600P4840 SV9601P4115 ^c					

^a Regulator setting in replacement control differs from original. Adjust to rated pressure as necessary for optimum performance.

^b Requires reducer accessory (included).

^c Replacement control includes purge time not included with original control.

^d These models were field convertible to LP gas. If the appliance has been converted to LP gas, use SV9602P4832 as the replacement.

^e These models were field convertible to natural gas. If the appliance has been converted to natural gas, use SV9602P4824 as the replacement.

Honeywell

Automation and Control Solutions

Honeywell International Inc.
1985 Douglas Drive North
Golden Valley, MN 55422

Honeywell Limited-Honeywell Limitée
35 Dynamic Drive
Scarborough, Ontario
M1V 4Z9

