

### VP5 19C AIR DIVERTING VALVE

#### GENERAL

The VP5 19C is a two-position, three-way, air diverting valve with a normally open bottom inlet. It has spring loaded, self-adjusting Teflon cone packing and removable composition upper and lower seats.

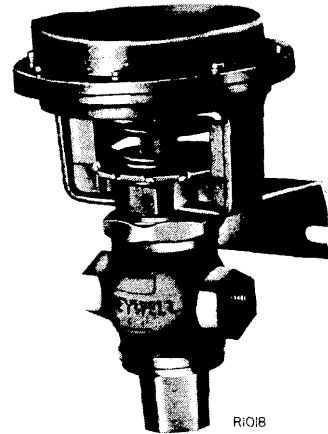

#### SPECIFICATIONS

NOMINAL BODY RATING: 150 psi (1034 kPa) maximum

**OPERATOR:**

- Maximum Safe (Pilot) Air Pressure: 25 psi (172 kPa)
- Maximum Ambient Temperature: 160 F (71C)
- Operating Range: 6 to 9 psi (41 to 62 nonadjustable)
- Close-Off Ratings at Various Air Pressures: See Fig. 1

PACKING AND DISC LIMITATIONS: See Table 1

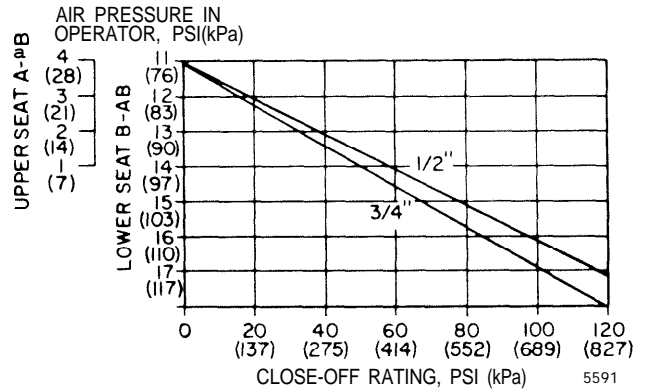

Fig. 1. Maximum Difference in Pressure Between Outlet and Inlet.

Table 1. Packing and Disc Limitations.

Valve Size	Cv	Travel	Packing Limitations			Disc Limitations		
			Temp Limits of Agent		Press Limits of Agent	Temp Limits of Agent		Max Press Differential
			Max	Min		Max	Min	
1/2 in.	5.5	1/4 in. (6 mm)	337 F 169 C	40 F 4 C	150 psi 1034 kPa	115F 46 C	35F 2C	75 psi 517kPa
3/4 in.	7.5	9/32 in. (7 mm)	337 F 169C	40 F 4 C	150 psi 1034 kPa	115F 46 C	35F 2C	75 psi 517kPa

## APPLICATION

The VP519C provides two-position action which operates as an air switch in large Day/Night or Summer/Winter changeover systems.

### OPERATION (See Fig. 2)

With 0 psi pilot pressure, the valve is open through ports B to AB and closed to port A furnishing 17 psi (117 kPa) supply pressure to the control system. With 13 psi (90 kPa) pilot pressure, the valve is open through ports A to AB and closed to port B furnishing 13 psi (90 kPa) supply pressure to the system.

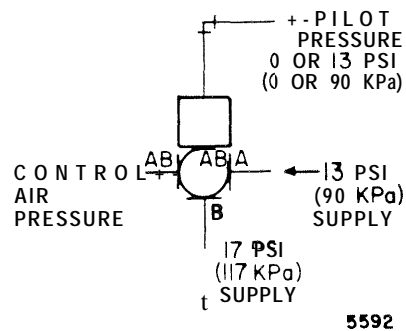

Fig. 2. VP5 19C Typical Operation.

## MAINTENANCE

### SPECIAL TOOLS REQUIRED

- 1 in. box wrench
- 0 to 30 psi (207 kPa) gage
- 15 psi (103 kPa) air source
- Crane Plastic Lead Seal
- Plasti-Lube No. 2 (Honeywell No. 3 11057)

### CAUTION

Use **EXTREME CARE** in the use of solvents. Avoid excessive inhalation and/or contact with skin. Careless handling can result in permanent damage to respiratory system or skin tissue.

### PRELIMINARY INSPECTION

1. Visually inspect for external trouble such as broken or kinked air lines, bad air connections, broken or damaged parts, or dust and dirt.
2. Check valve packing for air leakage. Packing gland is self-adjusting, and excessive tightening will not stop it from leaking. However, screw packing gland down all the way for proper service. Use 1 in. (25 mm) box wrench.
3. Keep both valve and actuator clean. Use brush to dust away any dirt from underside of actuator. Use cleaning solvent such as trichloroethylene but keep it away from diaphragm.
4. If packing is binding, or air is leaking around stem, repack valve (see REPAIR section).

### OPERATIONAL CHECK

1. Install 0 to 30 psi (207 kPa) pressure gage in valve branch line.

2. Vary branch line air pressure. Note pressure at which actuator starts its movement and pressure when movement stops. Correct starting point is approximately 6 psi (41 kPa), and movement ends at 9 psi (62 kPa).
3. Check stem travel. Stem travel on 1/2 in. model should be .250 in. (6 mm) and on 3/4 in. model, .281 in. (7 mm).
4. Check for proper output pressure in each valve position by measuring main air pressure at most convenient point.
5. If stem travel is jumpy or incomplete, check for bent or corroded valve stem, broken or weak spring, or foreign matter in valve. Failure to operate through complete stroke usually indicates a leaking air connection or a leaking diaphragm in the actuator. Tighten connections as necessary. Test diaphragm according to procedure outlined in SHOP TESTING section.

### CLEANING AND LUBRICATION

For sealing bonnet threads, use Crane Plastic Lead Seal (Crane Packing No. 2), obtainable from most plumbing suppliers. Sparingly use Plasti-Lube No. 2 (Honeywell No. 311057), 2 oz tube, to lubricate Teflon packing. For removing dirt or grease from valve assembly components, use trichloroethylene or similar solvent.

Keep solvent from touching diaphragm.

### ADJUSTMENT OF THE STEM BUTTON (Fig. 4)

If stem button screw (10) is removed or if height of stem button is disturbed during maintenance procedures, reset it. Locate top surface of stem button 4-1/2 in. (115 mm) above center line of ports A and AB when actuator is removed and lower disc (9) is against lower seat and outlet (17).

# TROUBLESHOOTING

## SPECIAL TOOLS REQUIRED

- Three 0 to 30 psi (207 kPa) gages

If malfunction in system is traced to valve, use Table 2 to find cause. Make repairs or replacements according to instructions in REPAIR section.

Make certain control air pressure is adequate and controlled air pressure is within design pressure of valve.

To effectively troubleshoot VP5 19C valve, install a 0 to 30 psi (207 kPa) air gage in the three valve lines if none exist. The pressure reading on the gage in the line from the valve port AB should always be equal to the pressure of the entering air, whether this air enters at port A or port B. VP519C is normally open to port B. With control air pressure of 5 psi (34 kPa) or less on the operator, port B is open to port AB. With control air pressure of 10 psi (69 kPa) or more, port A is open to port AB.

Table 2. Troubleshooting Guide.

Trouble	Possible Cause
Insufficient gage reading at port AB.	Leakage around valve packing gland, or at valve connections. Foreign material in valve. Worn discs. Bent or corroded valve stem. Leaky diaphragm. Pressure reducing valve(s) defective.
Excessive pressure at port AB (when valve is open to low-pressure supply port).	Foreign matter in valve. Worn discs. Bent or corroded valve stem. Pressure Reducing Valves defective. Weak or broken spring.

## SHOPTESTING

### SPECIAL TOOLS REQUIRED

- Three accurate 0 to 30 psi (207 kPa) air pressure gages
- One pressure reducing valve
- An air apply of 17 psi (117 kPa)

- Two stop cocks
- One jar of water
- Soap and water solution to check for leaks

Remove valve from system for shop testing. Refer to Fig. 3 for shop testing hookup.

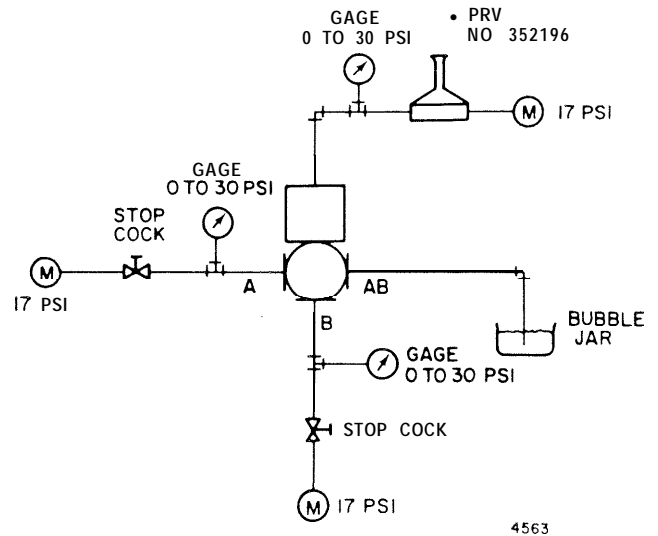

Fig. 3. Test Hookup.

Proceed as follows:

1. Apply 15 psi (103 kPa) pressure to valve actuator by adjusting PRV in branch line. Check all valve connections for leaks with soapy water solution.
2. Reduce pressure in branch line to zero.
3. Open stop cock to port A. Note gage readings at port A (17 psi [ 117 kPa ]), If any leaks are noted in bubble jar, upper composition disc is probably worn and needs replacing. (See REPAIR section.)
4. Close stop cock to port A.
5. Increase pressure in branch line to 15 psi (103 kPa).
6. Open stop cock to port B. Note gage reading at port B (17 psi [ 117 kPa ]). If any leaks are noted in bubble jar, lower composition disc is probably worn and needs replacing. (See REPAIR section.)

# REPAIR

## SPECIAL TOOLS AND MATERIALS REQUIRED

- Plasti-Lube No. 2 (Honeywell No. 3 11057)
- 1 in. box or socket wrench for packing nut
- Trichlorethylene solvent
- Pressure bulb assembly (Warehouse No. 852 or equivalent)

### CAUTION

Use **EXTREME CARE** in the use of solvents. Avoid excessive inhalation and/or contact with skin. Careless handling can result in permanent damage to respiratory system or skin tissue.

NOTE: Do not attempt to disassemble valve by taking actuator top off before removing operating spring. Do not attempt to replace defective parts while valve is in service.

## REMOVING ACTUATOR FROM VALVE (Fig. 4)

1. Provide 4 to 8 psi (28 to 55 kPa) air pressure to actuator with pressure bulb and draw valve stem retainer (3) away from locked position with screwdriver,
2. Shut down system air pressure and remove air lines from actuator.
3. Loosen two setscrews (16) and pull actuator from valve.

## ACTUATOR DISASSEMBLY (Fig. 4)

1. Loosen two socket head cap screws (8) alternately, a few turns at a time. Hold lower spider (7) securely while removing screws. Remove lower spider.
2. Remove spring support ring (15) from lower spider.
3. Lift out spring (6), spring cup (11), and stem retainer.
4. Remove diaphragm cup (5). Cup is held in place by suction of diaphragm only.

5. Remove top mounting screws (13), and lift off top (12) and diaphragm (4).
6. Inspect all parts, particularly diaphragm, for damage and wear. Select necessary replacement parts from PARTS section. Before reassembling actuator components, clean with trichloroethylene or similar solvent. Remove all grease and dirt that accumulated. Protect diaphragm from solvent.

NOTE: Diaphragms used for repair purposes come packed in plastic bags along with small amount of dry powdered lubricant. Lubricant prevents diaphragm material from adhering to metal of actuator cup and top.

Reassemble actuator parts using reverse order of disassembly procedure as guide.

NOTE: To convert a Series 1 actuator to Series 2, simply replace entire actuator assembly with new 3 13744A assembly per above procedure.

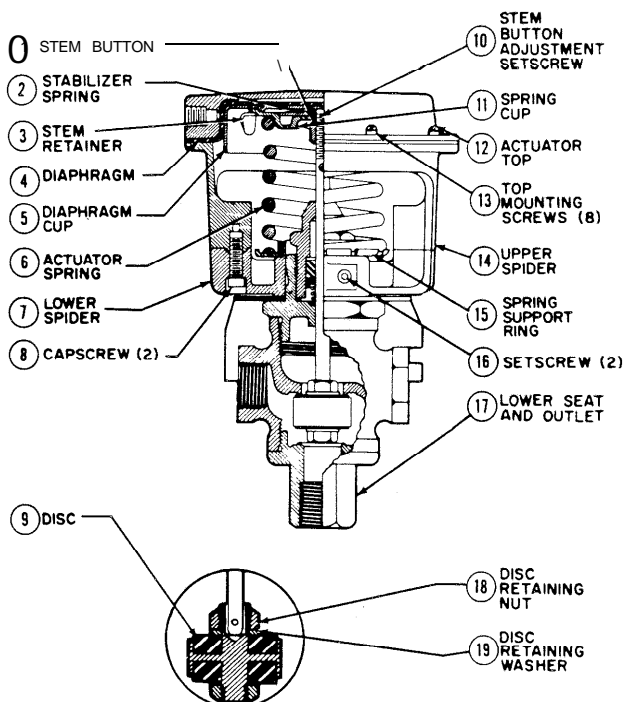

Fig. 4. Detail of Actuator.

4564

## REPACKING VALVE

1. Shut down system; apply 4 psi (28 kPa) control air with PRV or pressure bulb until completion of Step 2, below. Then turn off control air and remove air line.

2-10. Refer to Fig. 5 for steps 2 through 10.

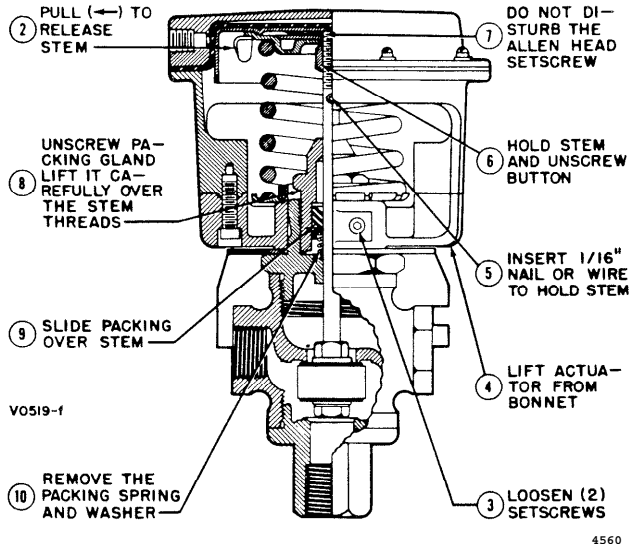

Fig. 5. Repacking Procedures (Steps 2 through 10).

11. Clean packing gland, spring, washer, packing cavity and valve stem with trichloroethylene.
12. Put a small amount of Plasti-Lub No. 2 on Teflon rings, upper half of stem, and inside of packing gland. Replace packing spring and follower. Place new Teflon rings on stem, one at a time, pointing toward valve seat (note Fig. 5). Be careful not to scratch or tear rings while sliding into place. Screw them over threaded part of stem if necessary.

13. Lubricate stem passage in top of packing gland with small amount of Plasti-Lube No. 2 and reassemble packing gland assembly. Turn packing gland down tight.
14. Replace stem button, taking care not to move setscrew in button. Hold stem by inserting nail in 1/16 in. hole just below stem button, and screw button on securely. If setscrew is loosened for any reason, reset original distance between top of stem button and valve bonnet.
15. Install actuator on valve.

## REPLACEMENT OF VALVE DISCS (Fig. 4 and 5)

1. Follow steps 1 through 10 under REPACKING VALVE.
2. Disconnect piping from lower seat and outlet (17) and remove lower seat and outlet. Pull stem and disc holder assembly out through opening in valve body,
3. Hold disc holder firmly with padded slip-joint pliers and remove disc retaining nuts (18) with 7/16 in. wrench. Remove disc retaining washers (19).
4. Remove two discs (9) and replace with new ones ordered from PARTS section.
5. Reassemble in reverse order of disassembly. Stake disc retaining nuts (18) in place with small center punch on reassembling to prevent loosening when valve is returned to service.

Check valve packing and replace if it appears worn. Refer to step 11 under REPACKING VALVE in this section.

## NOTES

# PARTS LIST

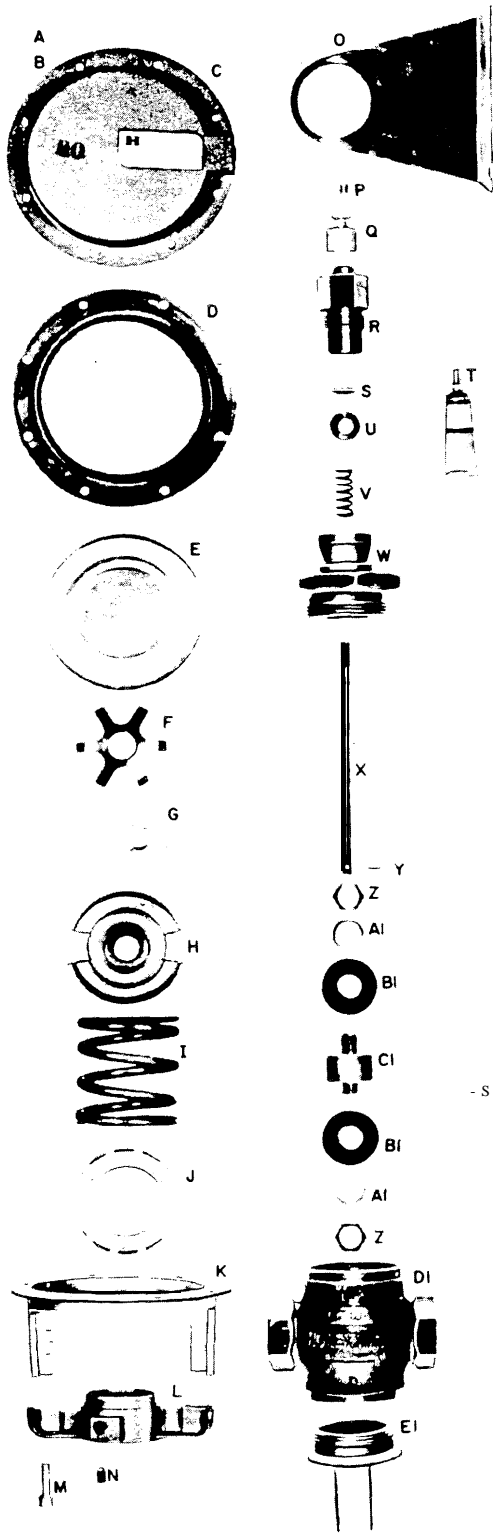

Sept. 1960 Series 2 Part No.	Key	Series I Part No.	Description
3 13744A	A	80272H	ACTUATOR ASSEMBLY-mc Gems A through N
14000661-	B	304488	* SCREW-No. 6-32 x 1/2 in.-fil hd-top mtg-(8)
313744	c		* WASHER, Spring Lock No. 6-top mtg-(8)
312760	D		TOP, Actuator
	E	3092842 1	DIAPHRAGM, Actuator
	F	310664	CUP, Diaphragm
	G	310502-767	SPRING, Stabilizer
	H	310501-605	RETAINER, Stem
	I	312350-605	CUP, Actuator Spring
3 10665-062	J	310507	SPRING, Actuator (Black Color Code)
14004616001	K		RING, Spring Support
80897AB-767	L	3 1058*	**SPIDER ASSY, Upper
14003034-206	M		SPIDER, Lower
	N	304200	* SCREW- 1/4-20 x 3/4 m.-socket hd-upper spider to lower spider mtg-(2)
	O	312320	* SETSCREW-1/4-20 x 3/8 in.-socket hd-cup pt-actuator to valve mtg-(2)
	P	304466	BRACKET, Valve Mounting
	Q	14004623-001	*SETSCREW-1/4-28 x 1/4 in.-socket hd-oval pt - stem button ad]
	R	310509	BUTTON, Stem
	S	310623	GLAND, Packing
	T	311057	PACKING, Cone-Teflon-(3)
	U	310506	LUBRICANT, Packmg-7 oz tube -enough for 25 packings
	V	3 10498	FOLLOWER, Packing
	W	14004630-004	SPRING, Packmg
	X	312319	BONNET, Valve
	Y	304688	STEM, Valve
	Z	304685	PIN, Disc Holder Retainmg
	A 1	304686	NUT, Disc Retaining-(2)
	B 1	312933	WASHER, Disc Retaining-(2)
	C 1	312919	DISC, Valve -(2)
313466	D 1		HOLDER, Disc
313447	D 1		BODY, Valve -1/2 in.
	E 1	14004603-002	BODY, Valve -3/4 in.
	E 1	14004604-002	LOWER SEAT AND OUTLET-for 1/2 in. valve
	E 1		LOWER SEAT AND OUTLET-for 3/4 in. valve

\*Standard hardware item  
 - Same as Series J  
 To order parts, contact the nearest Honeywell Commercial Branch Office  
 \*\*Includes self-tapping top (C) and lower spider (L) screws.

Fig. 6. Exploded View-VP5 19C.