

VP522A, B Sequencing Water Valve

SERVICE DATA

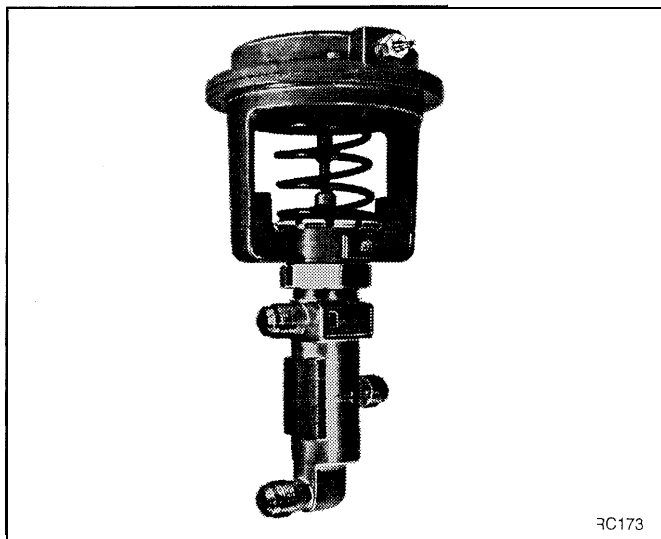

Application

The VP522A controls the flow of hot or cold water to a fan coil unit from the hot or chilled water supply piping.

The VP522B is used in conjunction with the VP522A as a diverting, return-water valve on four-pipe systems to ensure isolation of the hot and chilled water circuits.

Operation

The VP522A (Fig. 1) is a proportioning valve that controls the flow of first hot and then cold water to a fan coil unit as branchline pressure increases and the reverse as branchline pressure decreases. No flow occurs at mid-pressure. See Table 1 for operating sequence.

The VP522B diverts the return water from the coil directly to return piping of the system feeding the coil. During the dwell period of the VP522A, when both ports are closed but the valve is moving towards opening either the hot or cold port, the VP522B is actuated to open the proper port before the VP522A allows water to flow.

GENERAL

Description

VP522 Sequencing Water Valves are pneumatically actuated, three-pipe water valves that control both hot and cold water flow to fan coil units in three- and four-pipe systems.

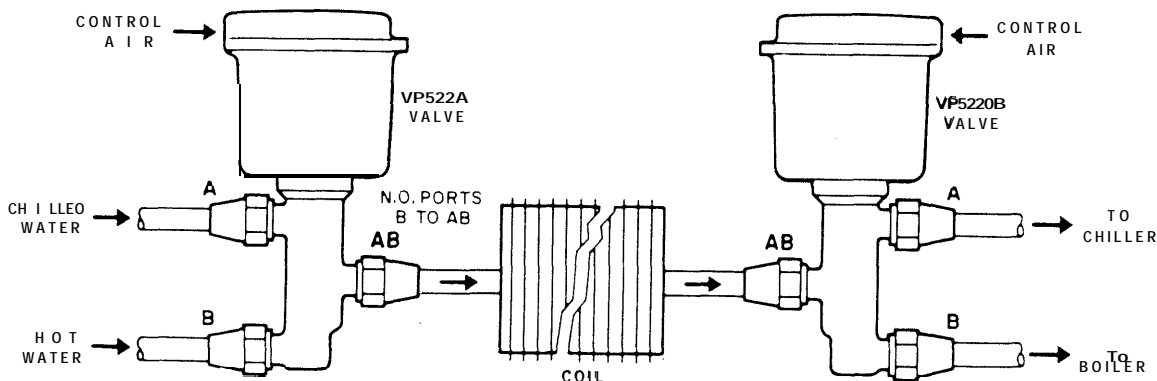

7033

Fig. 1. VP522A, B Typical Application.



Table 1. VP522A, B Operating Sequence on Control Air Pressure increase.

VP522A		psi (kPa)	VP522B
3/8 in Nominal	1/2 & 3/4 in. Nominal		All Sizes
Hot port open 100%	Hot port open 100%	0 (0) 1 (7) 2 (14) 3 (21) 4 (28)	Hot port open 100%
Hot port closes	Hot port closes	5 (34) 6 (41) 7 (48)	Hot port closes
Both ports closed	Both ports closed	8 (55) 9 (62)	Both ports closed Cold port opens
Cold port opens	Cold port opens	10 (69) 11 (76) 12 (83)	
Cold port open 100%	Cold port open 100%	13 (90) 14 (97) 15 (103)	Cold port open 100%

Specifications

See Table 2 for **VP522** model number, size, capacity index, and close-off rating.

Table 2. VP522 Specifications.

Model No.	Valve Size (Inches)		Capacity Index (Cv)		Close-Off Rating psi (kPa)
	Nominal	Copper Tubing O.D.	Port A	Port B	
VP522A1005	3/8	1/2	1.5	1.5	50 (345)
VP522A1039	1/2	5/8	2.5	1.6	50 (345)
VP522A1047	3/4	7/8	4.0	2.5	45 (310)
VP522A1054*	5/8	3/4	4.0	2.5	50 (345)
VP522A1062†	3/8	1/2	1.0	0.2	50 (345)
VP522A1070†	3/8	1/2	0.9	0.5	50 (345)
VP522A1088†	3/8	1/2	1.5	0.9	50 (345)
VP522A1096†	3/8	1/2	0.9	0.9	50 (345)
VP522A1104†	3/8	1/2	0.5	0.25	50 (345)
VP522A1120†	3/8	1/2	0.5	1.5	50 (345)
VP522A1138†	3/8	1/2	1.5	0.5	50 (345)
VP522A1146†	3/8	1/2	0.5	0.5	50 (345)
VP522A1161†	3/8	1/2	0.25	0.25	50 (345)
VP522A1179†	3/8	1/2	1.5	0.25	50 (345)
VP522A1187†	3/8	1/2	0.7	0.25	50 (345)
VP522A1195†	3/8	1/2	0.7	0.5	50 (345)
VP522A1203†	3/8	1/2	0.7	0.7	50 (345)
VP522A1211†	3/8	1/2	0.9	0.7	50 (345)
VP522A1229†	3/8	1/2	1.5	0.7	50 (345)
VP522A1237†	3/4	7/8	2.5	2.5	50 (345)
VP522B1003	3/8	1/2	1.5	1.5	§
VP522B1011	1/2	5/8	2.5	2.5	
VP522B1029	3/4	7/8	4.0	3.5	

* Not available for replacement. Use valve with different nominal pipe size and same capacity index.

† Not available for replacement. Use valve with different capacity index.

§ Rating will maintain closure against 15 psi (103 kPa) difference in return line pressure when used with VP522A. Combination is subject to maximum differential pressure limits of VP522A.

Nominal Body Rating:
250 psi (1724 kPa)

Water Temperature Limits:
35F (2C) min to 250F (121 C) max

Packing:
Rubber V-ring, spring loaded, self adjusting

Seats:
Brass, upper seat removable, lower seat integral

Plugs:
Brass

Disc:
Molded-in composition

Operator Diaphragm:
Molded neoprene, rolling type

Operator Maximum Safe Air Pressure:
25 psi (172 kPa)

Air Connections:
Combination barb fitting for 5/32-in. and 1/4-in. (4 mm and 6 mm) O. D. plastic tubing

- ② Adjust the system temperature controller through its control range. The valve should operate to control the flow of water as required to provide heating or cooling (when both hot and chilled water are available).
- ③ Make sure the branchline pressure builds up to near full main pressure when controller is set at the extreme end of the throttling range. With the temperature controller set at either extreme setting, full flow should occur. There should be no flow at mid-pressure (see Table 1).

Adjustment

Make the following adjustments after repairing the VP522A or B.

- ① Vary the branchline pressure to the inlet port on the VP522A. Note the pressure range at which no movement (dwell) occurs.
- ② Repeat above procedure for the VP522B.
- ③ Use a screwdriver or spring adjustment wrench to adjust the tension of the spring on the VP522B by turning the spring clockwise to reduce, or counter-clockwise to increase, the switching point of no movement. The switching point must be within the VP522A dwell.

MAINTENANCE

Equipment Required

- Commercial cleaning solvent degreaser
- 0 to 30 psi (0 to 107 kPa) pressure gage

Cleaning

Remove all dirt and grease accumulation from the underside of the actuator and around the packing nut and stem. Use solvent if necessary.

A WARNING

Use solvents in a well ventilated area. Avoid prolonged inhalation of solvents or contact with the skin. Careless handling of solvents can cause permanent injury to the respiratory system and skin tissue.



CAUTION

Do not allow solvent to come into contact with the diaphragm as it will cause serious damage.

Operational Check

- ① If a gage is not already present, insert a 0 to 30 psi (0 to 107 kPa) gage in the branch line.

TROUBLESHOOTING

For troubleshooting the VP522A or B, see Figure 2.

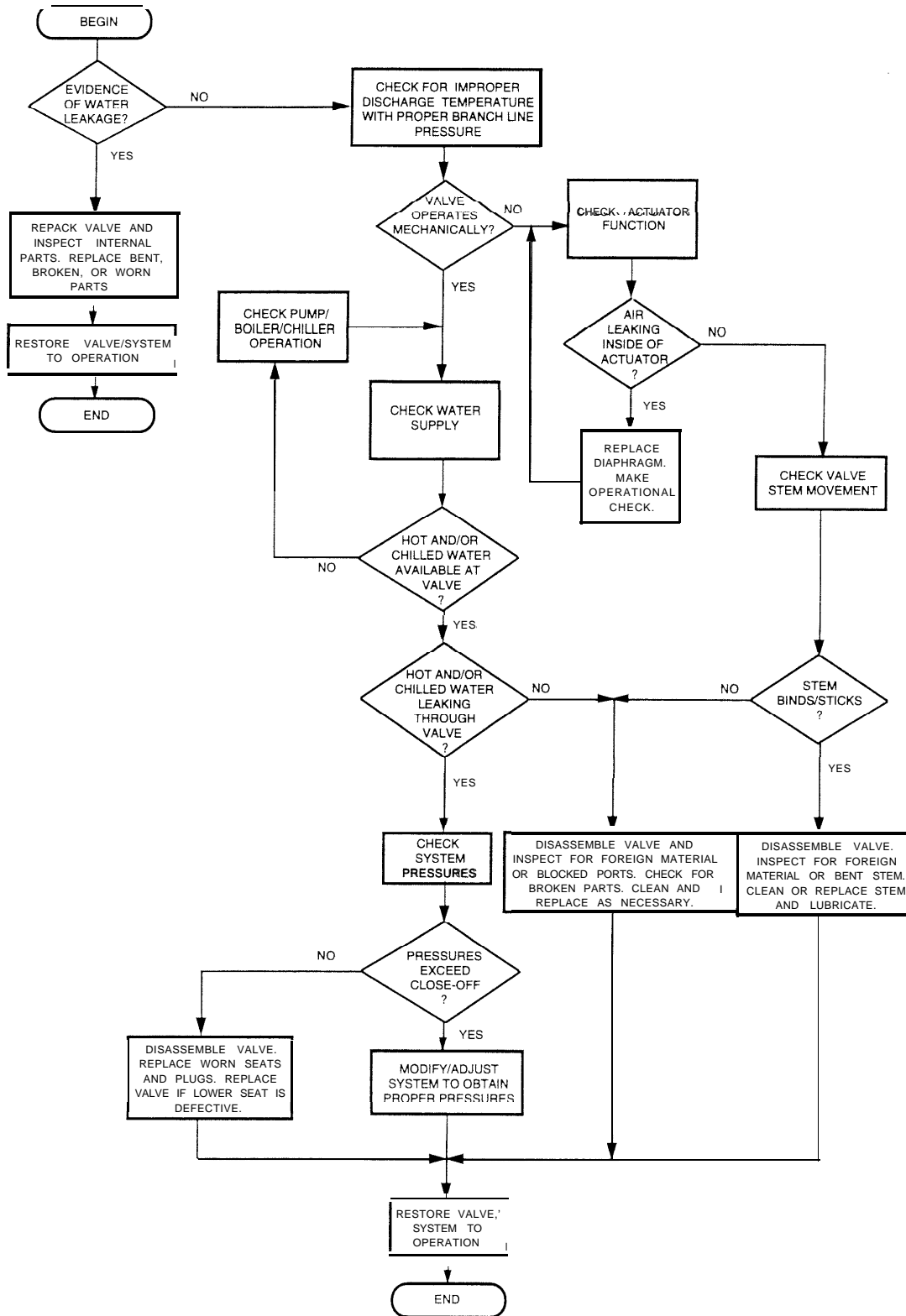

Fig. 2. VP522 Troubleshooting Flowchart.

REPAIR

Equipment Required

Valve Seat Removal Tool (available from Memphis Service Center):

- CCT3843 – for 1/2-in. O. D. copper tubing (3/8-in nominal) valve size
- CCT3833 -for 5/8- and 7/8-in. O.D. copper tubing (1/2- and 3/4-in. nominal) valve sizes

14002734-001 Lubricant for stem, packing, and packing nut
Lead Seal Number 2) or Crain packing of Teflon tape for bonnet threads.

Diaphragm Replacement

Refer to Figure 3 and Table 3 while performing this procedure.

- ❶ Shut off air supply to VP522.
- ❷ Disconnect air piping at actuator assembly.
- ❸ Disengage slide from stem button.
- ❹ Loosen the two socket head screws securing the actuator assembly to the valve bonnet, and lift off actuator assembly.

WARNING

The actuator is spring loaded via the large coil spring. To avoid personal injury, carefully loosen the two filister head screws from the spider base. Alternate a few turns at a time while firmly holding the spider base down against the spider.

- ❺ Turn actuator upside down on a flat surface and disassemble to remove spring load.
- ❻ Turn actuator back over and remove top and diaphragm.
- ❼ Inspect diaphragm cup at this time. If the cup is badly corroded, replace it.
- ❽ Reassemble actuator assembly in reverse order with new diaphragm.
- ❾ Replace the actuator assembly on the valve bonnet and tighten the two socket head screws.
- ❿ Engage slide on the stem button.
- ⓫ Reconnect air piping.
- ⓬ Turn air supply back on.

Packing Replacement

Refer to Figure 3 and Table 3 while performing this procedure.

- ❶ Shut off air supply to VP522.
- ❷ Remove actuator assembly as outlined in Steps 1 through 4 of DIAPHRAGM REPLACEMENT.
- ❸ Remove the stem button and slide the brass tube off of the stem and disc holder assembly. A hole is provided

near the top of the stem for insertion of an awl, nail, or similar tool to hold the stem while removing or replacing the stem button.

- ❹ Remove packing nut.
- ❺ Remove packing discs (3) and packing followers from packing nut. Retain both packing followers. Discard old packing.
- ❻ Remove packing spring from valve bonnet.
- ❼ Clean out packing nut and packing spring with a commercial solvent degreaser.

⚠ WARNING

Use solvents in a well ventilated area. Avoid prolonged inhalation of solvents or contact with the skin. Careless handling of solvents can cause permanent injury to the respiratory system and skin tissue.

- ❽ Inspect the spring and replace if necessary.
- ❾ Inspect the valve stem for scratches or abrasions, and replace if necessary. See STEM AND DISC HOLDER REBUILD KIT.
- ❿ Lubricate packing spring, stem, and new packing.
- ⓫ Assemble packing discs (cup down) and previously removed packing followers (bevel up) in the proper sequence.
- ⓬ Slide packing spring over stem into valve bonnet.
- ⓭ Carefully screw packing disc and spring follower "sandwich" over stem threads.
- ⓮ Apply light coating of lead seal or two wraps of Teflon tape to bonnet threads.
- ⓯ Install packing nut, brass tube, and stem button.
- ⓰ Install actuator assembly on valve body and secure.
- ⓱ Restore system to operation.

Stem and Disc Holder Rebuild Kit

NOTE: When ordering a replacement stem and disc holder rebuild kit listed in Table 4, a new brass tube, stem button, setscrew, and three packing discs are also included. When replacing the stem and disc holder assembly, the other parts included should also be replaced.

Refer to Figure 3 and Tables 3 and 4 while performing this procedure.

- ❶ Shut off air supply to the VP522.
- ❷ Remove actuator assembly as outlined in Steps 1 through 4 of DIAPHRAGM REPLACEMENT. Remove packing discs and packing followers as in Steps 2 and 3 of the PACKING REPLACEMENT section.
- ❸ Remove valve bonnet for access to upper valve seat.
- ❹ Inspect and replace the upper seat, if necessary, using the required valve seat removal tool.
- ❺ While the valve is open, check the integral lower seat in the valve body for wear and clean out any foreign matter that may be in the valve body. If the lower seat is bad, replace the entire valve assembly.
- ❻ Install the new stem and disc holder assembly and/or upper seat.
- ❼ Reassemble other parts in reverse order.

- 8 To assure correct stem stroke, tighten the valve bonnet and pull up on the stem to take up the free travel of approximately 1/16-in. With the stem raised (no free travel), adjust the stem button so that the distance from the top of the stem button to the top of the valve bonnet is 3-15/16 in. (100 mm) for the VP522A, or 4-1/16 in. (103 mm) for the VP522B.
- 9 Without moving the stem button on the stem, tighten the setscrew in the top of the stem button.
- 10 Put the actuator assembly back on.
- 11 Restore system to operation.

PARTS AND ACCESSORIES

Parts List

See Figure 3 and Tables 3 and 4 for available VP522 replacement parts.

Table 3. VP522A and B Parts List (See Fig. 3).

Fig. Key No.	Part No.	Description
2	---	Screw-8-32 x 1/2 in. slot head (4)
3	---	Lockwasher, No. 4 (4)
4	---	Actuator top
4	312760	Diaphragm
4	310673	Diaphragm for Series 1 Valves
5	309284A-00043	Diaphragm Cup and Support Assembly
6	---	Spider
7	---	Star Spring
a	---	Slide
9	---	Spring Plate
10	313816-00063	Spring for all A models except A1039 and A1047
10	314436-00065	Spring for A1039 and A1047 models
10	315412	Spring for B1011 and B1029 models
10	315413	Spring for B1003 model
11	---	Spring Retainer
12	---	Spider Base
13	---	Screw-1/4-20 x 3/8 in. socket head
14	---	Screw-1/4-20 x 3/4 in. filister head
15	---	Screw-1/4 x 1/4 in. socket head
16	---	Stem Button
17	314460	Brass Tube for A models
17	315409	Brass Tube for B models
18	---	Packing Nut
19	310143	Packing Discs (3)-cup down
20	310137	Packing Follower (2)-bevel up
21	310135	Packing Spring
22	---	Valve Bonnet
23	313825	Valve Seat for all A models except A1039, A1237, and A1047; for all B models except B1011 and B1029
23	314456	Valve Seat for A1039, A1237, and B1011 models
23	314462	Valve Seat for A1047 and B1029 models
24	See Table 4	Stem and Disc Holder Assembly
25	---	Valve Body

Accessories

No accessories are available for the VP522A or B.

Table 4. Stem and Disc Holder Rebuild Kit*.

O-S. No.	Part No.
VP522A1005	313824A
VP522A1039	314459A
VP522A1047	3144598
VP522A1070	313824C
VP522A1088	313824D
VP522A1096	313824E
VP522A1237	314459c
VP522B1003	315407A
VP522B1011	315408A
VP522B1029	315408A

* Also includes stem button and set screw, packing, and instructions.

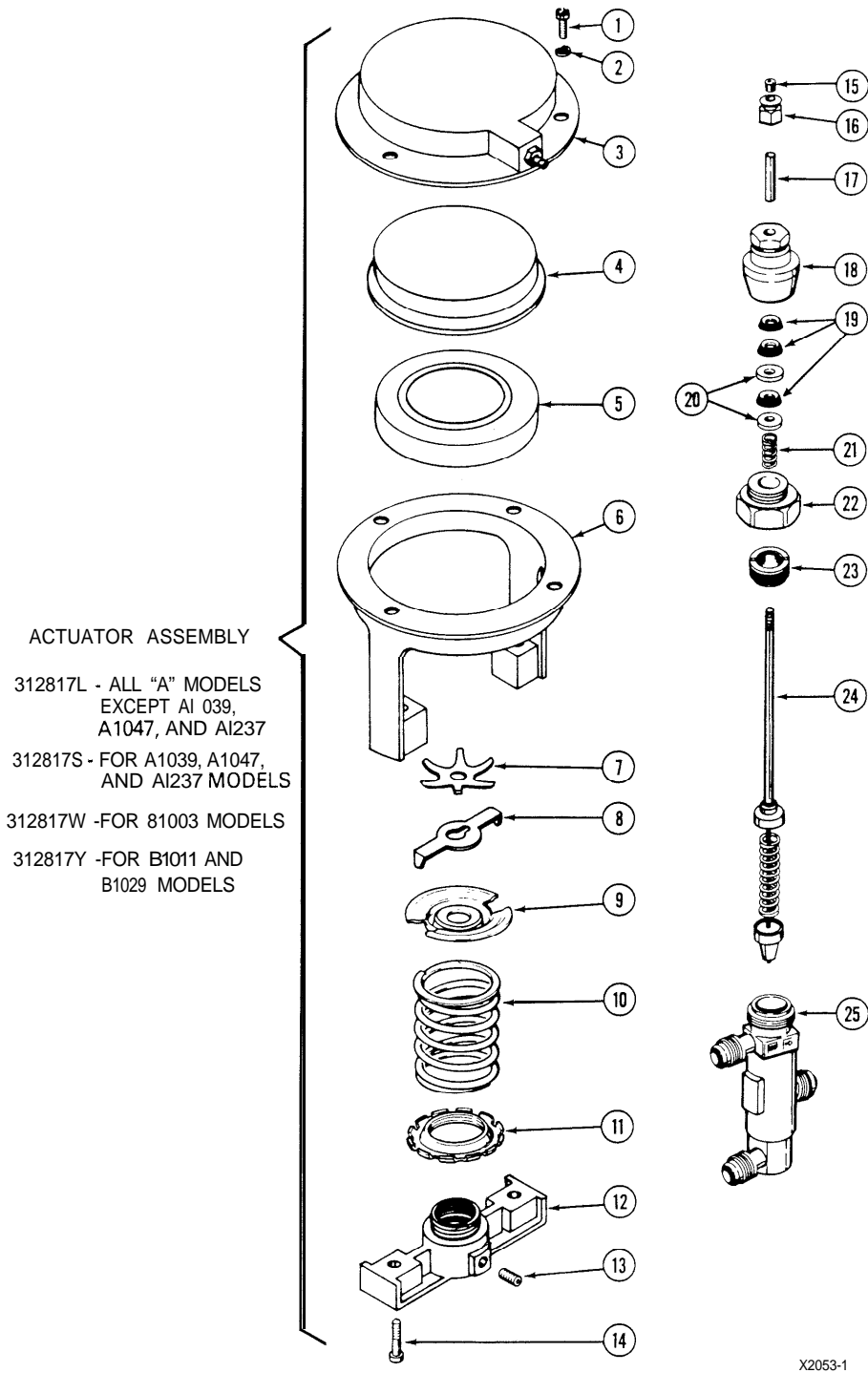

Fig. 3. VP522A and B Exploded View (See Table 3).

Honeywell

Helping You Control Your World

Home and Building Control

Honeywell Inc.
Honeywell Plaza
P.O. Box 524
Minneapolis, MN 55408-0524

Home and Building Control

Honeywell Limited-Honeywell Limitée
740 Ellesmere Road
Scarborough, Ontario
M1P 2V9