

HP970A, B and HP972B Pneumatic Humidistats

SERVICE DATA

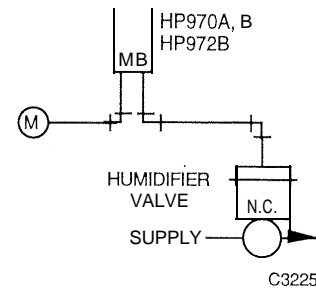
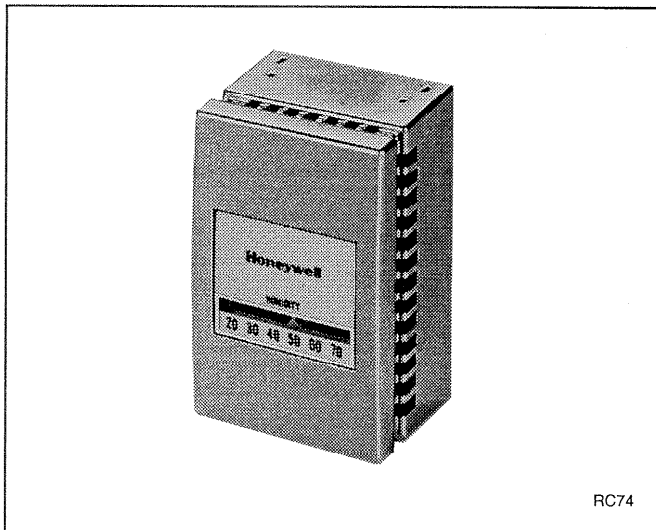

Fig. 1. Typical HP970A, B or HP972B Humidistat Two-Pipe Hookup.

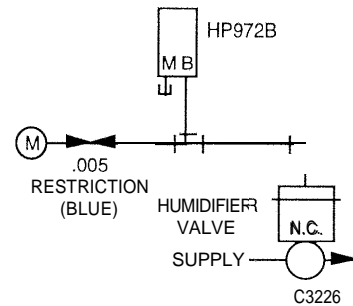

Fig. 2. Typical HP972B Humidistat One-Pipe Hookup.

GENERAL

DESCRIPTION

The HP970A, B and HP972B Pneumatic Humidistats (Humidistats) are nylon element, proportional, two-pipe, devices used to control humidity in HVAC systems.

APPLICATION

The HP970A and B Pneumatic Humidistats control pneumatic valve and damper actuators in air conditioning systems requiring humidification and/or dehumidification.

The HP972B is used in systems requiring a reset of relative humidity as a function of outdoor air temperature, wide throttling range, or replacement of existing one-pipe humidistats. A special model, HP972B1013, has all the necessary adapter fittings to convert older models or competitors' humidistats. Figure 1 shows a typical HP970A, B, or HP972B two-pipe hookup. Figure 2 shows a typical HP972B one-pipe hookup.

SPECIFICATIONS

Action:

- HP970A: Direct Acting
- HP970B: Reverse Acting
- HP972B: Reverse Acting

Means of Adjustment:

External knob with internally adjustable setpoint locking stops for minimum and maximum settings

Maximum Safe Pressure:

25 psi (172 kPa)

Supply Air Pressure:

13 to 21 psi (90 to 145 kPa)
18 psi (124 kPa) nominal

Branchline Pressure Indication:

Self-sealing gage tap under the cover

Throttling Range:

HP970A, B: Adjustable TR factory set at 5% rh
 3 to 15% rh Low Range
 3 to 20% rh High Range

HP972B: Adjustable TR factory set at 12% rh
 7 to 35% rh Low Range

Temperature:

Ambient Operating: 45 to 125F (7 to 51C)

Storage: -30 to 150F (-35 to 65C)

First Manufactured:

1972

OPERATION

HP970A, B

HP970A and B sense changes in ambient relative humidity. The sensed change causes a proportional change in the branchline pressure (BLP) and changes the control actuator position by the same proportion. The HP970A (DA) increases and the HP970B (RA) decreases the BLP when the relative humidity increases.

HP972B

The HP972B (RA) provides an inverse branch pressure signal in relation to the sensed relative humidity. The wide throttling range allows a reset of relative humidity as a function of the outdoor temperature, preventing condensation during extreme winter conditions.

MAINTENANCE

GENERAL

The tools shown in Figure 3 and a sling psychrometer or Digital Relative Humidity Pen CCT915 are necessary to calibrate the Humidistats.

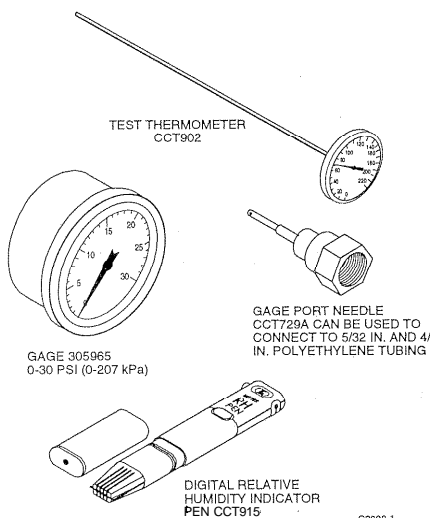

Fig. 3. Calibration Tools.

CLEANING

- ❶ If the Humidistat is in an area where it is exposed to dust or dirt, periodically remove the cover and use an air hose or soft brush to remove accumulated dust or dirt.
- ❷ If the nylon sensing element becomes contaminated with oil, grease, or dust, remove and clean it by gently agitating it in an acetone solution. Dry the element at room temperature. Reinstall the element and recalibrate the Humidistat.

CALIBRATION AND ADJUSTMENTS

THROTTLING RANGE ADJUSTMENT

The throttling range is factory set and should not require any change under normal operating conditions. If a change in relative humidity causes the system to hunt or the response is too slow, reset the throttling range as follows:

- ❶ If the system hunts or the controlled device cycles, move the throttling range indicator down. If the response is too slow, move the throttling range indicator up toward minimum.
- ❷ Recalibrate the Humidistat each time the throttling range is changed.

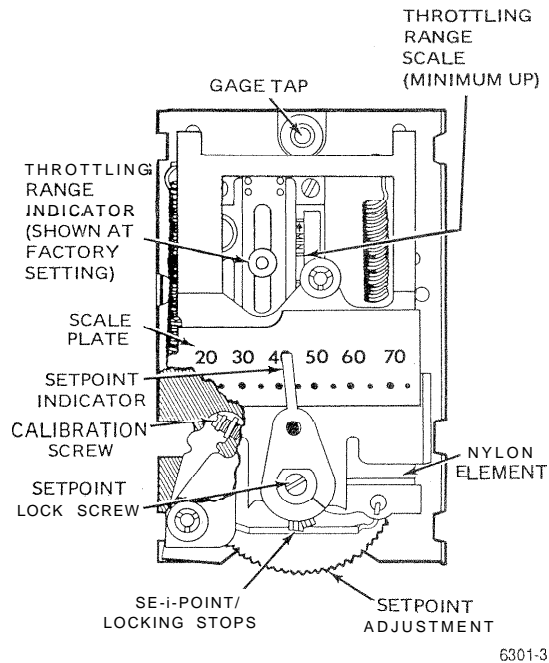

Fig. 4. Humidistat with the Cover Off and Showing the Adjustment Points.

SETPOINT LOCK ADJUSTMENT

Set the minimum and maximum setpoint as follows:

- ① Loosen the setpoint lock screw (Fig. 4).
- ② Move the setpoint locking stops to the desired position.
- ③ Tighten the setpoint lock screw.
- ④ Check the stop positioning by turning the setpoint adjustment.

CALIBRATION CHECK

HP970A

- ① Measure the rh with an accurate rh measuring device.
- ② Turn the setpoint adjustment until the setpoint indicator reads 10 percent below the indicated rh and allow the Humidistat to build up BLP.
- ③ Turn the setpoint indicator up slowly using the setpoint adjustment.
- ④ If the Humidistat bleeds off at 13 percent rh of the indicated humidity, no further calibration is necessary. If the Humidistat does not bleed off properly, proceed with RECALIBRATION.

HP970B and HP972B

- ① Measure the rh with an accurate rh measuring device.
- ② Turn the setpoint adjustment until the setpoint indicator reads 10 percent above the indicated rh and allow the Humidistat to build up BLP.
- ③ Turn the setpoint indicator down slowly using the setpoint adjustment.
- ④ If the Humidistat bleeds off at ± 3 percent rh of the indicated humidity, no further calibration is necessary. If the Humidistat does not bleed off properly, proceed with RECALIBRATION.

RECALIBRATION



CAUTION

These Humidistats are sensitive devices and should be handled with extreme care during calibration. Do not breathe directly on the element when the cover is off.

- ① Ensure the system is stabilized and the main air is maintained at normal pressure between 13 and 21 psi (90 and 145 kPa). Factory calibration is 18 psi (125 kPa).
- ② Remove the Humidistat cover.
- ③ Install the Pressure Gage into the gage tap (Fig. 4) using the Gage Adapter.
- ④ Measure the rh with an accurate rh measuring device.
- ⑤ Use the setpoint adjustment to set the setpoint indicator at the actual relative humidity.
- ⑥ Adjust the calibration screw (Fig. 4) until the Pressure Gage reads 0 psi (0 kPa).
- ⑦ Readjust the calibration screw slowly until the Pressure Gage reads 8 ± 1 psi (55 ± 7 kPa).
- ⑧ Allow sufficient time for a complete response and stabilization, then recheck pressure. The Humidistat is now calibrated.
- ⑨ Remove the Pressure Gage and Gage Adapter.
NOTE: If the gage tap fails to seal itself properly after the Pressure Gage is removed, bleed off a small amount of air and insert Gage Tap Plug 14002172-001 into the gage tap.
- ⑩ Replace the Humidistat cover.
- ⑪ Set the Humidistat at the desired setting.

TROUBLESHOOTING

Table 1 lists common Humidistat problems, their possible causes, and solutions. For any problems not covered in Table 2, Troubleshooting Flowchart (Fig. 5).

Table 1. Common Problems, Causes, and Solutions.

Problem	Possible Cause	Solutions
Excessive noise	The gage tap or air lines are leaking	Correct the air line leakage or install Gage Tap Plug 14002172-001 in gage tap.
	Oil is present in the air lines.	<ol style="list-style-type: none"> 1. Flush out the system with refrigerant or install an oil filter, if necessary. 2. Replace the restrictor block assembly and filter cartridge (see REPAIR). 3. Check the compressed air supply for the cause.
	Air leak in restrictor block and filter assembly	<ol style="list-style-type: none"> 1. Use bubble solution to locate the leak and repair it. 2. Replace the restrictor block assembly and filter. 3. Install Stiffener Plate 14004609-001 on the backplate.
Slow response	Inadequate air flow is caused by an incorrect cover.	Install a correct cover.
	The Humidistat is installed in a dead air space	70 ft/min is required for a proper response. Relocate the Humidistat or use an aspirator box.
	Inadequate air flow is caused by a partially clogged restrictor block assembly and/or filter cartridge.	Replace the restrictor block assembly and/or filter cartridge (see REPAIR).
Rapidly changing humidity conditions	The valve is too large.	Check the valve size and replace the valve if necessary.
	The humidifier is oversized.	Modify the humidifier or replace it with a correctly sized one.
Constant readings	The Humidistat is calibrated inaccurately.	Recalibrate the Humidistat.
	The humidifier is undersized.	Replace the humidifier with a correctly sized one.
	The humidifier jets are clogged.	Clean the jets.
Variable load	In areas where paper or other dry material is moved into a controlled space, the material will absorb moisture faster than the humidifier can supply it, causing a temporary loss of control.	Eventually, as the material continues to absorb moisture, the system will catch up and regain control.
Inaccurate readings	The backplate is over-tightened.	Install Stiffener Plate 14004609-001 on the backplate.
Air leak	Branchline plug is leaking.	Install Gage Tap Plug 14002172-001 in gage tap.

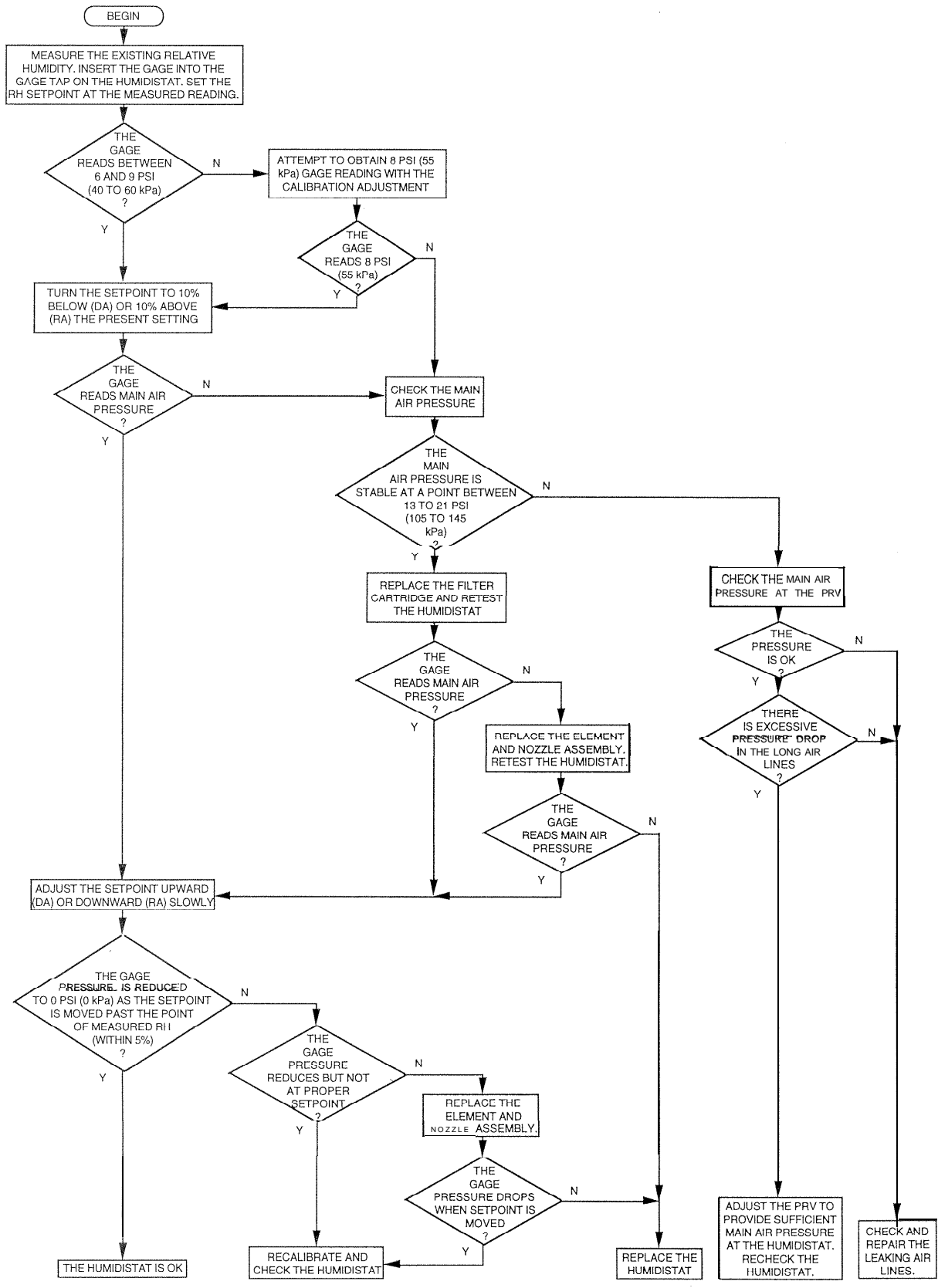

C3224

Fig. 5. Humidistat Troubleshooting Flowchart.

REPAIR

GENERAL

If the Humidistat requires replacement, do not remove the existing mounting plate from the mounting surface, or adjust or repair any piping.

HUMIDISTAT REPLACEMENT

- 1 Remove the Humidistat cover.
- 2 Remove the old Humidistat, leaving the airhead connected to the mounting plate.
- 3 Discard the new mounting plate.
- 4 Align the port holes (Fig. 6) on the back of the replacement Humidistat with the air connections on the existing airhead.
- 5 Snap the new Humidistat onto the old mounting plate.
- 6 Calibrate the new Humidistat.
- 7 Reinstall the Humidistat cover.

NOTE: If the gage tap fails to seal itself properly after Pressure Gage 14003519-001 is removed, bleed off a small amount of air and insert Gage Tap Plug 14002172-001 into the gage tap.

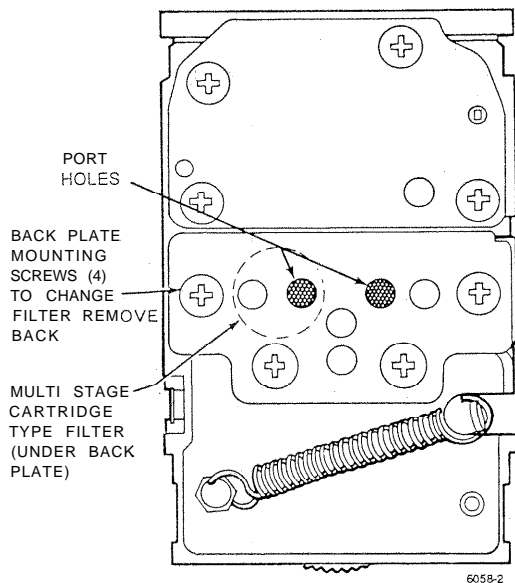

Fig. 6. Humidistat Back View.

SCALEPLATE REPLACEMENT

- 1 Remove the Humidistat cover.
- 2 Insert a small screwdriver blade between the setpoint indicator and the scaleplate assembly (Fig. 7) and pry the setpoint indicator up off the setpoint cam and wheel assembly.
- 3 Carefully pry off the two retaining rings from the scaleplate mounting posts.
- 4 Detach the scaleplate locking tab at the right of the Humidistat base and lift off the scaleplate assembly.
- 5 Using the retaining rings included with the new scaleplate assembly, install the new scaleplate in reverse order. Be certain to align the flat of the setpoint pointer with the flat on the hub of the setpoint cam and wheel assembly.
- 6 Check calibration of Humidistat and recalibrate if necessary.
- 7 Reinstall the Humidistat cover.

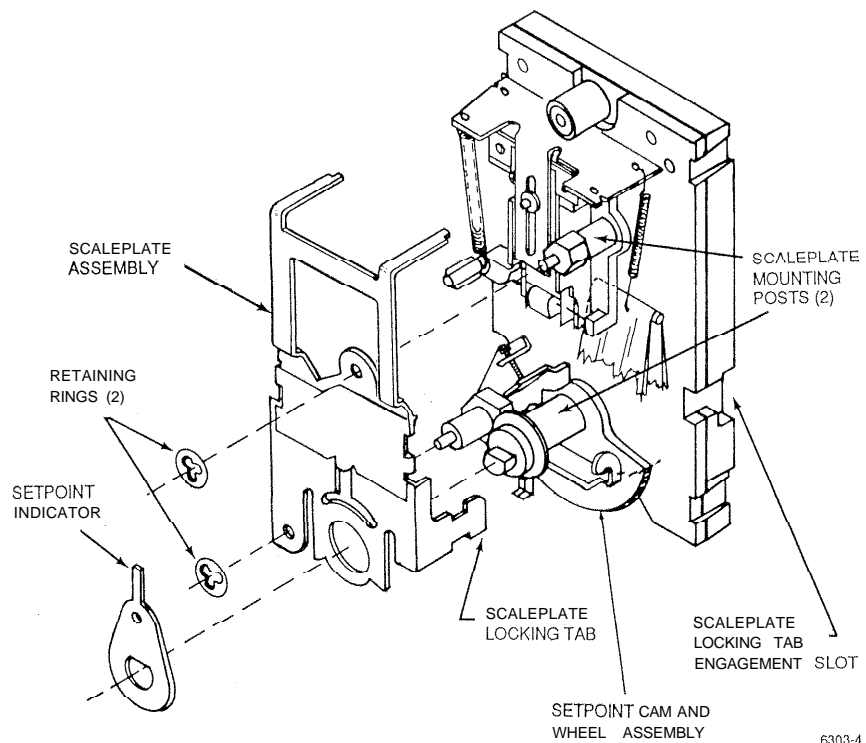

Fig. 7. Scaleplate Replacement.

SETPOINT CAM ASSEMBLY REPLACEMENT

- 1 Follow Steps 1 through 4 of SCALEPLATE REPLACEMENT.
- 2 Disconnect the relief spring (Fig. 8) from the calibration lever arm on the back of the Humidistat.
- 3 Carefully unhook the element assembly yoke (Fig. 9 and IO) from the hook of the calibration lever, located immediately above and to the right of the setpoint wheel.
- 4 Swing the element assembly (Fig. IO) up and to the right. It is not necessary to disengage the element assembly coil spring from the nylon element or nozzle and flapper assembly bracket.
- 5 Remove the pivot post (Fig. 9) at the left of the setpoint wheel, the setpoint lever, and the calibration lever. Do not lose the spacer positioned between the base and the calibration lever.
- 6 Lift out the old setpoint cam and wheel assembly and install the replacement unit in reverse order. Make certain that the two levers are free to move.
- 7 Recalibrate the Humidistat.
- 8 Reinstall the Humidistat cover.

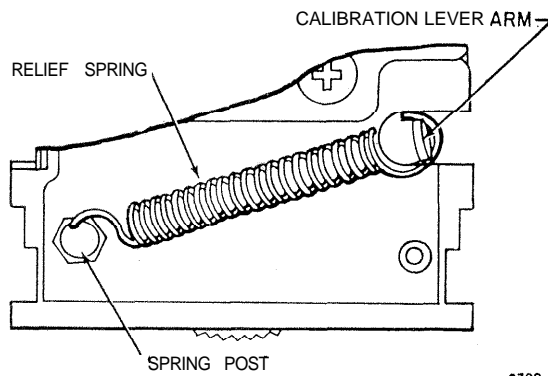

Fig. 8. Back of the Humidistat Showing Relief Spring Connections.

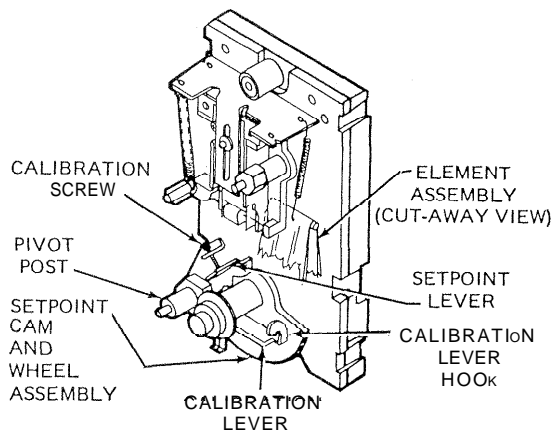

Fig. 9. Humidistat with Scaleplate Removed Showing Setpoint Cam Assembly.

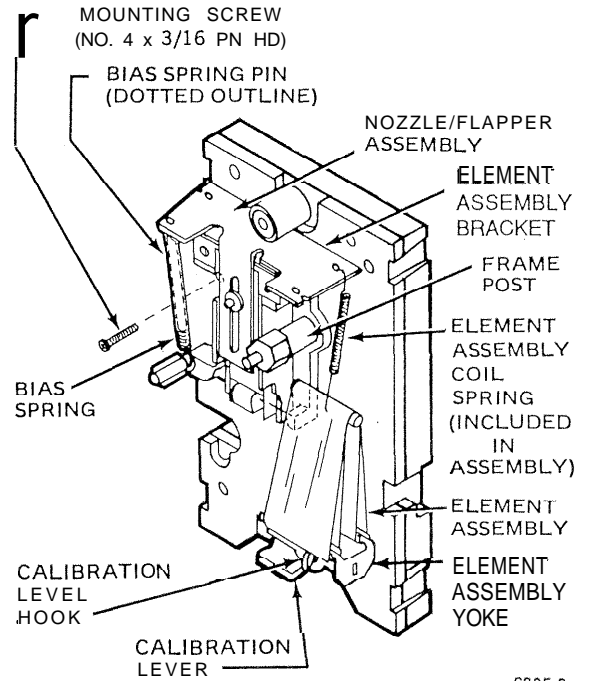

Fig. 10. Humidistat with Scaleplate and Setpoint Cam Assembly Removed Showing Element Assembly and Nozzle/Flapper Assembly.

ELEMENT ASSEMBLY REPLACEMENT

- 1 Follow steps 1 through 4 of SCALEPLATE REPLACEMENT.
- 2 Unhook the coil spring of the element assembly bracket (Fig. 10).
- 3 Disengage the element assembly yoke from the calibration lever hook located directly above the setpoint wheel.
- 4 Remove element assembly and install replacement unit in reverse order.
- 5 Recalibrate the Humidistat.
- 6 Reinstall the Humidistat cover.

NOZZLE/FLAPPER ASSEMBLY REPLACEMENT

- 1 Follow steps 1 through 4 of SCALEPLATE REPLACEMENT.
- 2 Unhook the coil spring of the element assembly from the nozzle/flapper assembly bracket (Fig. 10).
- 3 Unhook the bias spring from its anchor post.
- 4 Remove the frame post and mounting screw.
- 5 Lift the nozzle/flapper assembly from the base.
- 6 Remove the O-ring from the rear of the nozzle/flapper assembly.
- 7 Disengage the other end of the bias spring from the bracket hole. Do not lose the small pin located inside the spring.
- 8 Assemble the O-ring and the bias spring to the replacement nozzle/flapper assembly and reinstall in reverse order.
- 9 Recalibrate the Humidistat.
- 10 Reinstall the humidistat cover.

RESTRICTOR BLOCK ASSEMBLY AND FILTER CARTRIDGE REPLACEMENT

CAUTION

When replacing these parts, use extreme care to prevent dirt, dust, or debris from entering various openings of the Humidistat base or the restrictor block.

- 1 Remove the Humidistat cover.
- 2 Remove the Humidistat.
- 3 Access to the restrictor block assembly and filter cartridge is from the rear of the base assembly. Remove the four mounting screws from the restrictor block (Fig. 11).
- 4 Carefully lift off the restrictor block (Fig. 11).
- 5 Remove the flat rubber gasket from the restrictor block. The filter cartridge is located in the gasket.
- 6 Remove the filter cartridge from the gasket.
- 7 Align the gasket on the base assembly, and insert the new filter cartridge into the recess in the base with the screen end of the filter exposed.
- 8 Place the new restrictor block over the gasket and filter cartridge, and replace the four mounting screws.
- 9 Snap the Humidistat onto the mounting plate.
- 10 Recalibrate the Humidistat.
- 11 Reinstall the Humidistat cover.

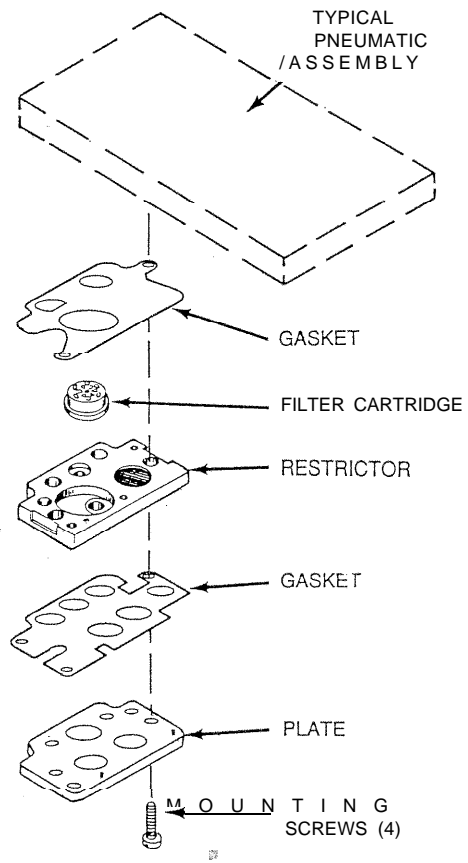

Fig. 11. Restrictor Block Assembly and Filter Cartridge Replacement.

PARTS AND ACCESSORIES

PARTS LIST

Table 2. HP970A, B and HP972B Pneumatic Humidistat Parts List.

Part No.	Description
14003659-001	Scafeplate Assembly, Blank
14002641-001	Scafeplate Assembly, 15 to 75 percent
14002641-002	Scafeplate Assembly, 65 to 95 percent
14002594-001	Setpoint Cam Assembly
14002496-001	Element Assembly, HP970A, HP970B1007
14002496-003	Element Assembly, HP970B1015, HP972B
14001 865-001	Filter Cartridge Assembly
14002374-004	Restrictor Block Assembly

COVERS

Table 3. HP970 Series Pneumatic Humidistat Covers.

Window insert	Setpoint	Part Number	Part Number Suffix*							
			Honeywell Logo				No Logo			
			Setpoint Slot				Setpoint Slot			
			Open		Closed		Open		Closed	
			Mounting		Mounting		Mounting		Mounting	
			Vert	Horiz	Vert	Horiz	Vert	Horiz	Vert	Horiz
No Window Insert	—	14004406-XXX*	—	—	-300	-400	—	—	-800	-800
		14004407-XXX*								
Honeywell	20-80 (% RH)	14004406-XXX*	-124	-224	-324	-424	—	—	—	—
		14004407-XXX*	-124	—	—	—	—	—	—	—
20 30 40 50 60 70										

*When ordering, use complete part number including three-digit suffix.

14004407-XXX Covers are paintable. See HP970-72 and TP970-74 Pneumatic Sensors, Humidistats, and Thermostats Installation instructions 95-5597 for painting information.

ACCESSORIES

Table 4. HP970A, B and HP972B Pneumatic Humidistat Accessories Parts List.

Part No.	Description
14002362-001	Duct Sampling Chamber
14002430-001	Heavy Duty Guard
14002573-001	Modernization Kit
14003-I 92-001	Wall Plate Adapter Kit
AK3996C	Duct Mounting Bracket
14002 172-001	Gage Tap Plug
14003519-001	Pressure Gage
MQP729 (CCT729)	Gage Adapter
MQT735A (CCT735A)	Thermostat Tool

Honeywell

Helping You Control Your World

Home and Building Control
Honeywell Inc.
Honeywell Plaza
P.O. Box 524
Minneapolis, MN 55408-0524

Home and Building Control
Honeywell Limited-Honeywell Limitée
740 Ellesmere Road
Scarborough, Ontario
M1P 2V9