

# RP920A-D Modular Pneumatic Controller

## Service Data

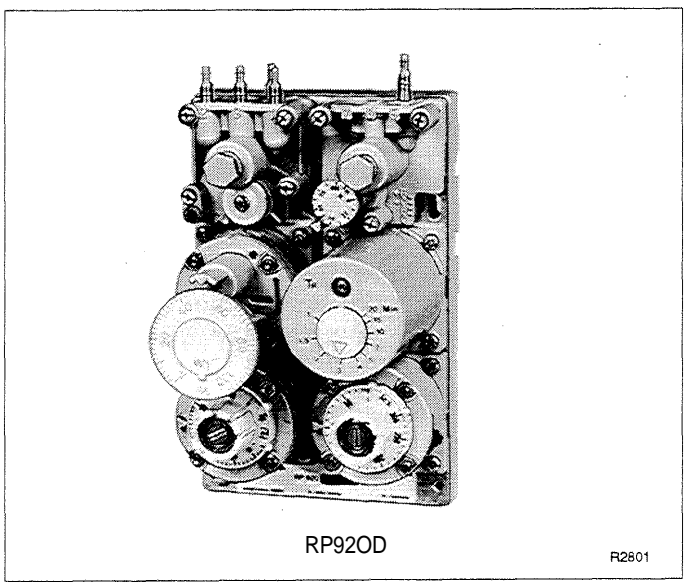

### TABLE OF CONTENTS

GENERAL .....	3
Description .....	3
Application .....	3
Specifications .....	4
Operation .....	4
RP920A or C Controller.....	4
RP920B or D Controller .....	4
MAINTENANCE.....	
Equipment Required .....	4
Inspection and Cleaning .....	5
Operational Check .....	5
All Systems .....	5
System in Operation .....	5
System not Operating-Sensors Disconnected .....	5
Equipment .....	5
PrOxdLu.e .....	5
Calibration Check.....	6
Operating Point (RP920A and B) .....	6
Operating Point as Maximum Limit (RP920C and D).....	6
Setpoint .....	6
Compensation Startpoint (RP920B and D) .....	
Calibration .....	7
RP920A .....	7
RP920B .....	7
RP920C and D .....	9
Adjustments .....	9
General .....	9

## TABLE OF CONTENTS (Continued)

Direct to Reverse Acting.....	11
Negative to Positive Compensation (RP920B and D).....	11
Integral Action Cut-Off and Gage Function (RP920C and D).....	11
Setpoint Adjustment.....	12
Local Setpoint Adjustment.....	12
Remote Setpoint Adjustment.....	12
Control Point Adjustment (CPA Models Only).....	13
Proportional Band Adjustment.....	13
Authority Adjustment (RP920B and D).....	13
Compensation Startpoint Adjustment (RP920B and D).....	13
Reset Time Adjustment (RP920C and D).....	13
Cover.....	13
TROUBLESHOOTING.....	14
REPAIR.....	14
Module Replacement.....	14
Setpoint Knob Replacement.....	14
Filter/O-Ring Replacement in Connector Block Module.....	15
Gage Seal Replacement.....	15
PARTS AND ACCESSORIES.....	16
Parts List.....	16
Accessories.....	16
APPENDIX A.....	16

# GENERAL DESCRIPTION

The RP920 Modular Pneumatic Controller, in conjunction with remote sensors, provides Proportional (P) or Proportional Plus Integral (p + I) control of temperature, humidity, pressure, or dewpoint in WAC systems.

through the primary controller (RP920C) maintaining a constant mixed air temperature. The limit controller (RP920A) and limit sensor sets outdoor air intake to a minimum.

## APPLICATION

In the mixed air control application (Fig. 1), the primary sensor modulates the outdoor and return air dampers

In the hot water converter control application (Fig. 1), the primary sensor modulates the steam valve on the converter to maintain the hot water temperature. On CPA models the hot water temperature can be adjusted remotely using a gradual switch.

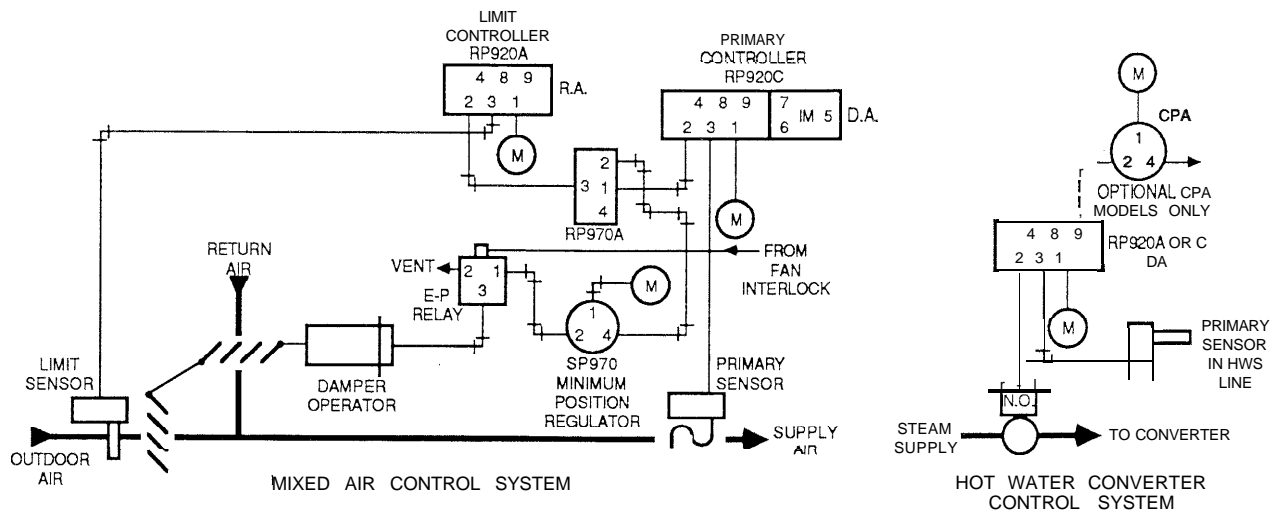

Fig. 1. Typical Single-Input Controller Applications.

In a dual-input control application (Fig. 2), the RP920B or D provides reset capability. Often, control of a building is more efficient if the setpoint of the controller is reset to a different value as a function of some parameter other than

the controlled variable, in this system, outdoor air temperature. To use compensation, a reset schedule must be set up (Fig. 3).

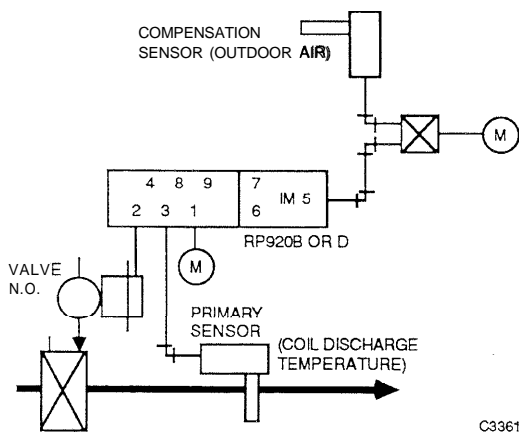
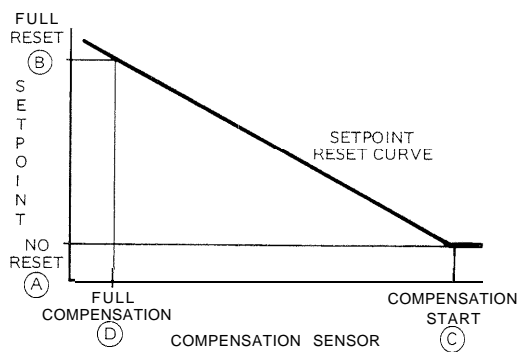

Fig. 2. Typical Dual-Input Control System.



WHERE:

- (A) = LOWEST VALUE OF CONTROLLED VARIABLE.
- (B) = HIGHEST VALUE OF CONTROLLED VARIABLE.
- (C) = VALUE OF COMPENSATION VARIABLE WHEN CONTROLLED VARIABLE IS AT ITS LOWEST VALUE.
- (D) = VALUE OF COMPENSATION VARIABLE WHEN CONTROLLED VARIABLE IS AT ITS HIGHEST VALUE.

21365-1

## SPECIFICATIONS

### Models:

- RP920A: Single-Input Controller
- RP920B: Dual-Input Controller
- RP920C: Single-Input P + I Controller
- RP920D: Dual-Input P + I Controller

### Main Air Supply:

18 psi (124 kPa)

### Minimum Air Pressure:

15 psi (103 kPa) minimum

### Maximum Safe Air Pressure:

30 psi (207 kPa)

### Input Signal:

3 to 15 psi (21 to 103 kPa)

### Output Signal:

3 to 13 psi (21 to 90 kPa)

### Air Consumption:

- RP920A and C: 0.021 scfm (9.9 ml/s)
- RP920B and D: 0.046 scfm (21.7 ml/s)
- Sensor: 0.019 scfm (9.0 ml/s) depending on sensor selected

### Air Capacity:

0.07 scfm (33.0 ml/s) at 18 psi (124kPa) with 1 psi (7 kPa) pressure difference

### Proportional Band:

2.5 to 50%, field adjustable

### Authority (RP920B and D Only):

5 to 300% of primary sensor span

### Compensation Start Point (RP920B and D Only):

0 to 100% of compensation sensor span

### Integral Reset Time (RP920C and D Only):

0.5 to 20 minutes, field adjustable

### Ambient Temperature:

40 to 130F (5 to 55C)

## OPERATION

### RP920A OR C CONTROLLER

In the mixed air control system with highlimit (Fig. 1), the primary controller modulates the outdoor and return air damper to maintain the mixed air temperature set on the controller. As the outdoor temperature rises through the narrow throttling range of the limit controller, the dampers are gradually returned to the minimum position as set on the minimum position switch. When the fan is off, the dampers assume the normal positions.

In the hot water converter control system (Fig. 1), the primary sensor in the hot water supply from the converter modulates the steam valve on the steam supply to the converter to maintain the hot water temperature. As the water temperature rises through the throttling range the valve moves from open to closed. If the CPA is used, it can change the control point temperature  $\pm 15$  percent x the sensor span.

### RP920B OR D CONTROLLER

In the dual-input control system (Fig. 2), the setpoint of the primary sensor, located in the discharge air, is reset by the compensation sensor in the outdoor air. Adjustments are made on the controller to change the discharge air temperature according to a predetermined compensation reset schedule (Fig. 3). The RP920D provides finer control in this application because of the integral action.

## MAINTENANCE

### EQUIPMENT REQUIRED

1. Gage 305965 (0- to 30-psi).
2. Gage Adaptor 729 with plug-in fittings.
3. Receiver Gage to match primary sensor (see Pneumatic Indication, Receiver, and Target Gages Specification Data 77-6091).
4. Barb Fitting 14003755-001 (integral models).
5. Controller Calibration Kit MQP8 16A,
6. Pneumatic Calibration Kit

## INSPECTION AND CLEANING

Occasionally, check for leaks and loose fittings and screws. Especially check the self-tapping screw in Port 8 and the self-tapping screw at the top of the integral module (RP920C and D).

NOTE: Once removed, self-tapping screws can be a source of air leakage because of a damaged O-ring. Check the O-ring and replace it if it is damaged,

Use a soft cloth or brush to remove accumulated dust and/or dirt from the RP920.

## OPERATIONAL CHECK

### ALL SYSTEMS

Be certain all adjustment settings and conditions are correct. See job drawing for proper settings. Table 1 is a list of the adjustments available on each model.

Table 1 .RP920 Adjustments.

Adjustment	Model			
	RP920A	RP920B	RP920C	RP920D
Setpoint	X	X	X	X
Proportional Band	X	X	X	X
Internal restrictor switch	X	X	X	X
Direct/reverse acting (proportional module position)	X	X	X	X
Authority		X		X
Compensation startpoint		X		X
Positive/negative compensation (switch block module position)		X		X
Reset time			X	X
Gage/integral cut-off (switch block gasket position)		X	X	X

### SYSTEM IN OPERATION

1. Be certain the HVAC equipment is functional.
2. Observe BLP. If it is not between 3 and 13 psi (21 to 90 kPa), slowly adjust the setpoint knob and/or CPA until the BLP is in the 3 to 13 psi (21 to 90 kPa) range. Allow the system to stabilize before continuing.
3. Measure the temperature, humidity, or static pressure at the main sensor. This should agree with the setpoint  $\pm 1/2$  of the throttling range. For the RP920B and D the measurement should agree with the reset schedule

$\pm 1/2$  of the throttling range as set by the authority and compensation startpoint. If a discrepancy exists, recalibrate the controller.

4. Move the setpoint slightly up and down. The BLP should change proportionally in the same direction for direct acting and in the opposite direction for reverse acting controllers. Repeat this step using the CPA if applicable. If the BLP responds properly, the controller is good. Return the setpoint and CPA to the original settings,

NOTE: The RP920C or D should maintain control closer to the setpoint or reset schedule than the RP920 A or B because of the integral action.

## SYSTEM NOT OPERATING-SENSORS DISCONNECTED

### EQUIPMENT

- 0- to 30-psi pressure gage.
- Restricted air supply, adjustable from 3 to 15 psi (21 to 103 kPa), with receiver gage to match sensors or Sensor Controller Calibration Kit MQP816A.
- Pneumatic Calibration Kit MQP800 (optional).

### PROCEDURE

1. Connect the 0- to 30-psi gage to Port 2 (branch).
2. Connect the main air supply to Port 1 (18 psi minimum).
3. Pipe a 3 to 15 psi (21 to 103 kPa) adjustable air supply with a receiver gage which matches the primary sensor to Port 3.
4. Pipe a second 3 to 15 psi (21 to 103 kPa) adjustable air supply with a receiver gage which matches the compensation sensor to Port 5 of an RP920B or D.
5. If checking a CPA model, pipe 9 psi to (62 kPa) to Port 9. The MQP800 or MQP816A can be used to supply 9 psi (62 kPa).
6. On an RP920C and D, remove and save the seal screw from the integral module (Fig. 12) and install Barb Fitting 14003755-001 in its place. Apply 8 psi (55 kPa) to the integral module. This prevents integral action. Without this procedure, it is necessary to allow additional time for the controller to finish responding to any change in input pressure or settings.
7. RP920A and C:
  - a. Adjust the input air pressure to Port 3 to correspond with the mid-point of the throttling range of the primary sensor (see APPENDIX A).

- b. Set the setpoint knob to the percent of span, temperature, or humidity that corresponds to the input pressure. The BLP should be 8 psi (55 kPa). If it is not correct, go to Step 10.
8. RP920B and D:
    - a. Plot the reset schedule to determine the corresponding compensation and primary sensor values.
    - b. Convert the reset schedule value to pressure (See APPENDIX A) and adjust the air supplies to those pressures. For an RP920D, the BLP should be 8 psi (55 kPa). For an RP920B, the expected BLP depends on which point on the reset schedule is being simulated. If BLP is not within 1 psi of the control point pressure, go to Step 10. Exact control point pressure can be established for each application by constructing a chart similar to that shown in Figure 4 and referencing APPENDIX A. If it is not correct, go to Step 10.
  9.
    - a. Move the setpoint knob until the BLP is 8 psi (55 kPa). Slowly increase the setpoint adjustment one division. The BLP should decrease proportionally if the controller is direct acting or increase proportionally if the controller is reverse acting.
    - b. Slowly decrease the setpoint one division. The BLP should change proportionally in the opposite direction of Step 9a.
    - c. For CPA models, repeat Steps 9a and 9b substituting the CPA knob for the setpoint knob.
    - d. If the controller works properly, go to Step 11. If the controller works properly, but is out of calibration, go to Step 10.
  10. To calibrate the controller:
    - a. Adjust the setpoint knob until the correct BLP is indicated on the gage.
    - b. Remove the setpoint knob. Replace it at the correct setting without changing the BLP. Return to Step 9.
  11. Connect the tubing and make settings according to the job drawings.

**NOTE:** On the RP920C and D, replace fitting in the integral module with the seal screw. Be sure the O-ring is sealed

**EXAMPLE:**

The hot water temperature is reset from 100 to 200F as the outdoor temperature goes from 60 to -10F. The range of the primary sensor is 40 to 240F and the compensation sensor is -40 to 160F. Additional settings taken from the job drawings are:

- Compensation startpoint = 60F (or 50 percent).
- Compensation is negative.
- Authority setting = 157 percent.

Throttling range = 10F.  
 Proportional Band = 5 percent.  
 Setpoint = 100F (or 30 percent).

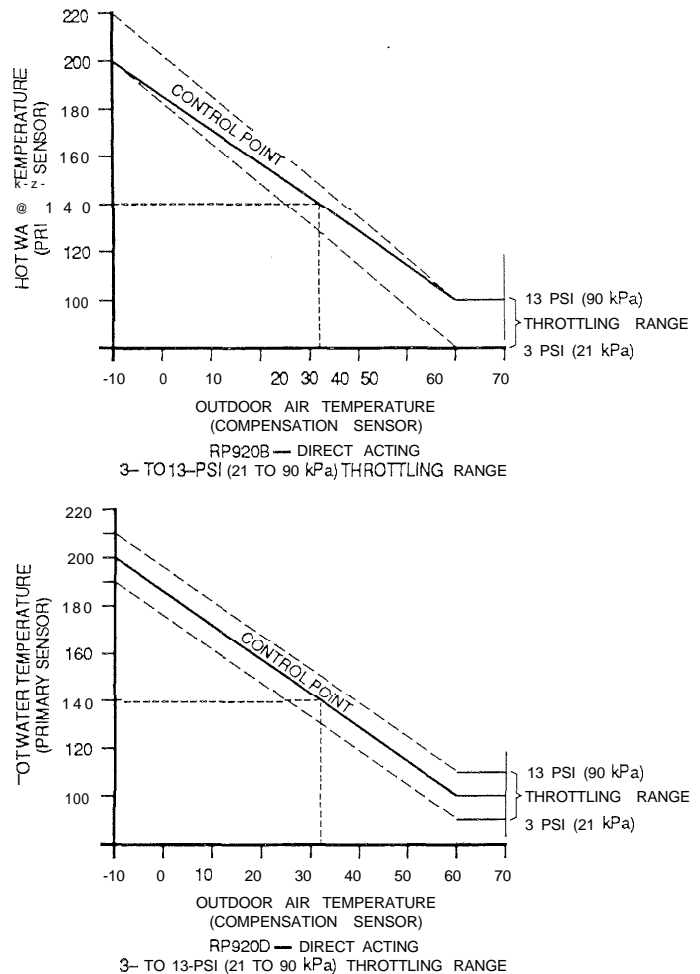

Fig. 4. RP920B and D Reset Schedule,

Select (Fig. 4) any compensation sensor value (outdoor temperature) within the compensation range, in this case 32F. Construct a line vertically to the control point line and then horizontally to the left side. The hot water temperature must be 140F to meet the reset schedule.

From APPENDIX A the input pressures are:

- Port 3 (primary) = 9 psi (62 kPa).
- Port 5 (compensation) = 7.3 psi (50.3 kPa).

The BLP should be 8 psi (55 kPa) for RP920D, or 9 psi (62 kPa) for RP920B .

**NOTE:** Previous discussion and illustration assumes 3 to 13 psi (21 to 90 kPa) operating range. However, the controller may be calibrated to match the spring range of the actuator (e.g., 4 to 11 psi). The expected BLP at the center of the actuator spring range (e.g., 7.5 psi).

# CALIBRATION CHECK

The RP920 is factory calibrated. If the controller does not operate properly, check the calibration as follows,

## OPERATING POINT (RP920A AND B)

1. Pipe the connections (Fig. 5). Install Barb Fitting 14003755-001 in Port 8.
2. Set the internal restriction to the blocked position. Adjust the setpoint knob to 50 percent. On the RP920B, adjust the compensation startpoint knob to 30 percent and set to negative compensation.
3. Adjust the proportional band to 50 percent and set for direct acting.
4. If the BLP is 8 psi (55 kPa), go to Step 5. If not, remove the setpoint knob (Fig. 6) and turn the operating point screw with a 5/64-inch Allen wrench until this value is matched,
5. Reinstall the self-tapping screw in Port 8.

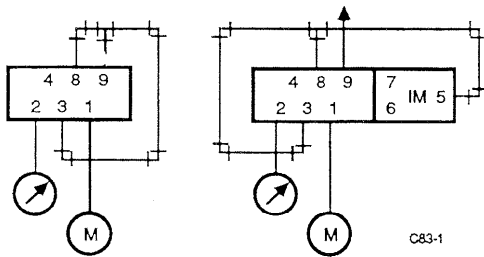

Fig. 5. Connections for Operating Point Check-RP920A and B.

## OPERATING POINT AS MAXIMUM LIMIT (RP920C and D)

1. Pipe the connections (Fig. 7). Install Barb Fitting 14003755-001 in Port 8 and in the top of the integral module. Connect the mainline to the integral module. This procedure requires 20 psi (138 kPa) minimum MLP.
2. Adjust the setpoint to 50 percent. On the RP920D adjust the compensation module to negative compensation and set the compensation startpoint to 30 percent.
3. Adjust the proportional module to direct acting and set the proportional band to 50 percent.
4. Adjust the reset time to 15 minutes.
5. If the BLP is 17.5 psi (120 kPa), go to Step 6. If not, remove the setpoint knob and turn the operating point screw with a 5/64-inch Allen wrench until this value is matched.
6. Reinstall the self-tapping screws in Port 8 and in the top of the integral module.

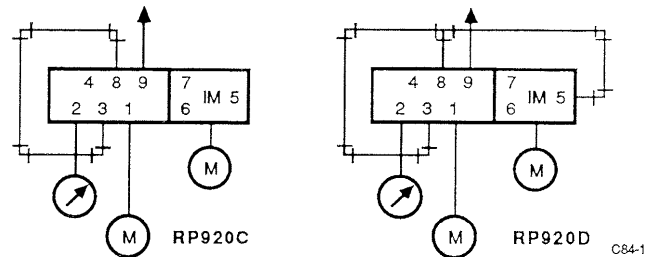

Fig. 7. Connections for Operating Point Check (RP920C and D).

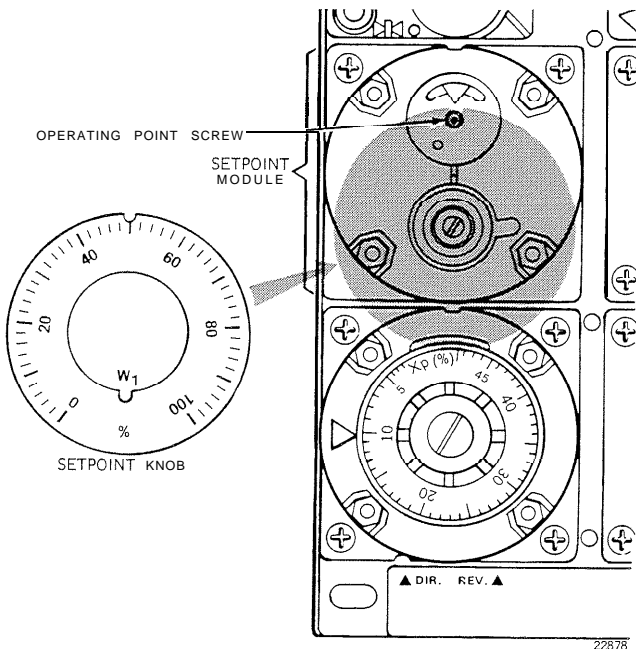

Fig. 6. Operating Point Screw Location.

## SETPOINT

1. Pipe the connections (Fig. 8). Install Barb Fitting 14003755-001 in Port 8.
2. Apply MLP.
3. Adjust the setpoint knob or screw until the gage reading is 9 psi (62 kPa).
4. The setpoint knob setting should be 50 ±2 percent. If not, remove the setpoint knob and replace it oriented to 50 percent.
5. Reinstall the self tapping screw in Port 8.

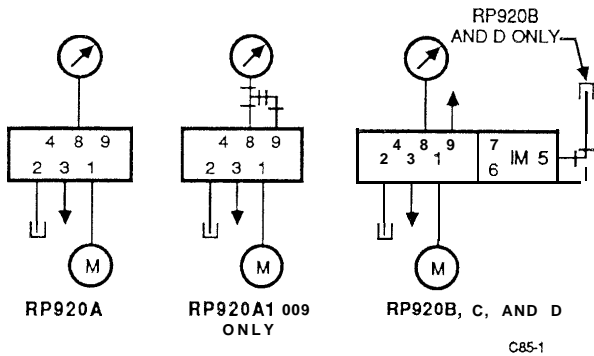

Fig. 8. Connections for RP920 Setpoint Check.

### COMPENSATION STARTPOINT (RP920B and D)

1. Pipe the connections (Fig. 9).
2. Apply MLP-
3. Adjust the startpoint knob or screw until the gage indicates 9 psi (62 kPa).
4. The setpoint knob setting should be  $50 \pm 2$  percent. If not, remove the setpoint knob and replace it oriented to 50 percent.

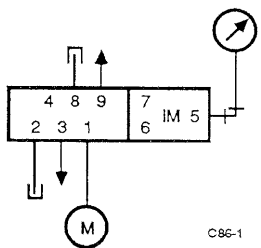

Fig. 9. Connections for RP920B and D Compensation Startpoint Check.

### CALIBRATION

NOTE: The following procedures can be used to calibrate the RP920, or the MQP816A Controller Calibration Kit can be used following procedures in CCT816B Calibration Unit Installation Instructions 95-7 153 .

### RP920A

1. If none exists, install a temporary receiver gage (matching primary sensor) or a 0- to 30-psi gage in the primary sensor gage port.
2. Apply MLP.
3. Install a 0- to 30-psi gage in the BLP test tap.
4. Adjust the setpoint knob until the BLP equals the centerpoint of the controlled device spring range.
5. If the setpoint and primary sensor gage do not match, remove the setpoint knob and replace it so the setpoint matches the actual primary sensor gage reading.
6. Readjust the setpoint to the desired setpoint.
7. Calibration is complete.

### RP920B

1. Supply the adjustable restricted air (equivalent to Controller Calibration Kit MQP816A) to Port 3 (primary sensor).  
NOTE: Sensors are not connected.
2. Pipe a receiver gage matching the compensation sensor, or a 0- to 30-psi gage to Port 5 of the RP920B.  
NOTE: If the controller switch block module gasket is in Position C, block Port 5 and use the existing gage.
3. If a BLP gage does exist, install a 0- to 30-psi gage in the branch line or in the BLP gage port if the switch block gasket is in Position B.
4. Apply MLP.
5. Adjust the compensation startpoint knob until the receiver gage indicates pressure equivalent of the compensation startpoint (Fig. 10 and 11).  
NOTE: Use APPENDIX A to find the equivalent pressures for the temperature, humidity, and percent of sensor span.

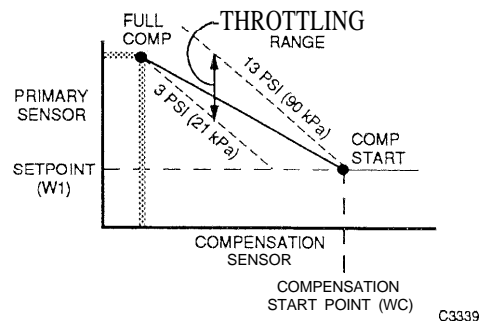

Fig. 10. Negative (Winter) Compensation Calibration Reset Schedule, Direct Acting Controller-3 to 13 psi Throttling Range.



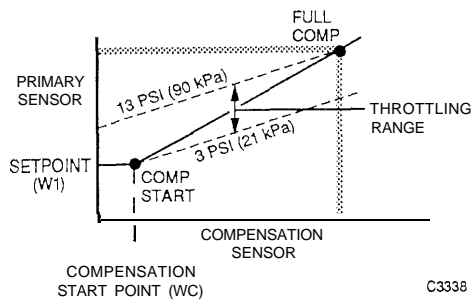

Fig. 11. Positive (Summer) Compensation Calibration Reset Schedule, Direct Acting Controller-3 to 13 psi (21 to 90 kPa) Throttling Range.

6. Adjust the restrictor for the equivalent pressure of the primary sensor at the compensation startpoint on the reset schedule.
7. Adjust the setpoint knob until the BLP equals the desired BLP at the compensation start conditions (e.g., 13 psi [90 kPa] for negative compensation, 3 psi for positive compensation).
8. If needed, remove the setpoint knob and reposition it so the setpoint matches the primary sensor value at the compensation start. The setpoint knob is calibrated.
9. Supply the adjustable restricted air (equivalent to Controller Calibration Kit MQP816A) to Port 5 (compensation sensor).
10. Adjust the restrictors for the equivalent pressure of the sensors at full compensation on the schedule.
11. Adjust the authority knob until the BLP equals the desired pressure of the controlled device with full compensation conditions.  
NOTE: This point can be slightly different from the calculated authority set on the controller. Leave the new setting on the controller and mark the job drawings with the new value.
12. Calibration is complete.

## RP920C AND D

1. Remove and save the screw from the RP920C or D integral module (Fig. 12) and install Barb Fitting 14003755-001 in its place.
2. Apply 8 psi (55 kPa) to the integral module.
3. Calibrate the RP920C following the procedures for the RP920A. Calibrate the RP920D following the procedures for the RP920B.
4. When calibration is complete, remove the barb fitting and replace screw. Be certain that the O-ring is tight.

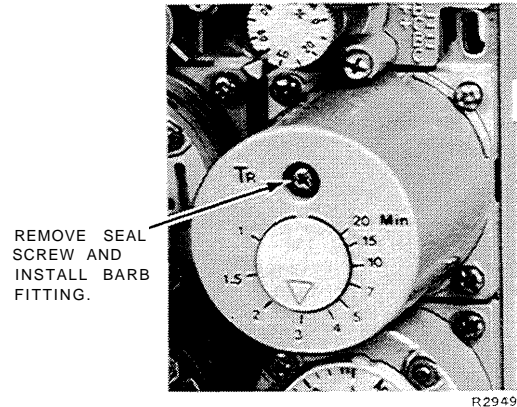
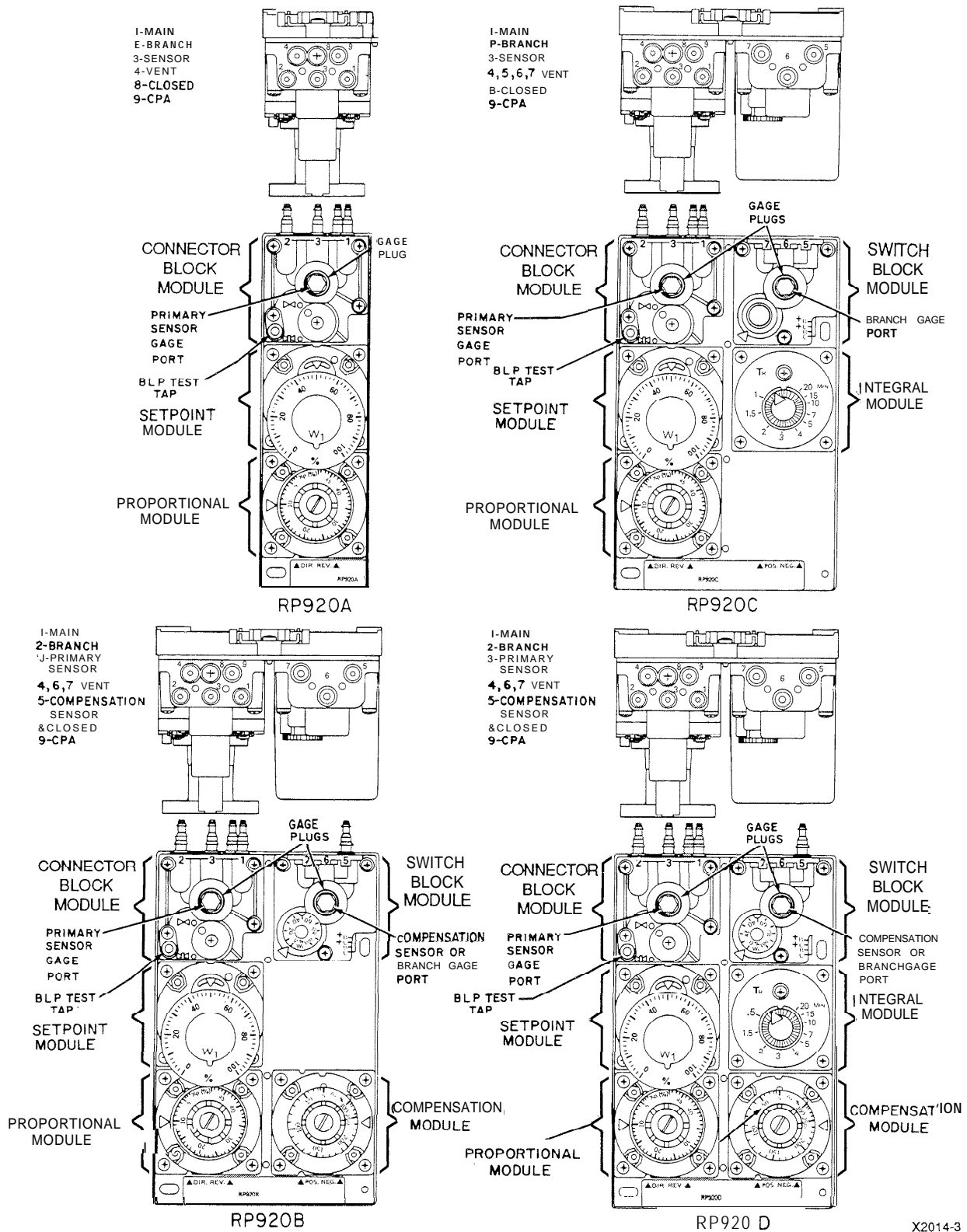

Fig. 12. Integral Module.

## ADJUSTMENTS

### GENERAL

1. Some adjustments on the RP920 Modular Pneumatic Controllers require removal of modules. Module and port locations are shown in Figures 13 and 14.
2. If a connection to Port 4, 6, or 7 is required, remove the self-tapping screw from Port 8 and use the screw to tap the port.
3. Install Barb Fitting 14003755-001 and O-ring finger-tight in the appropriate port.
4. If Port 8 is not used, reinstall the screw.



X2014-3

Fig. 13. Module and Port Locations.

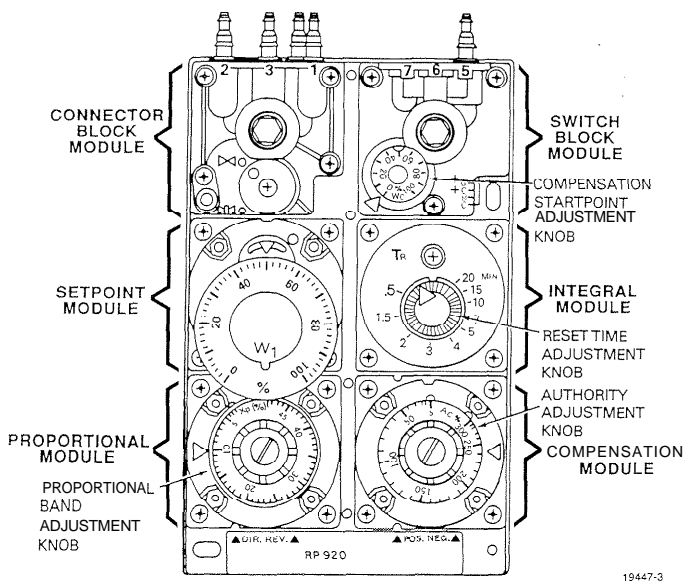

Fig. 14. RP920 Adjustment Locations.

### DIRECT TO REVERSE ACTING

1. Loosen the four screws (Fig. 15) on the proportional module.
2. Remove the module. Rotate the module and its gasket 180 degrees and reinstall. Ensure that the notch on the module lines up with the proper indication on the base.
3. Retighten the four screws.
4. If required, recalibrate.

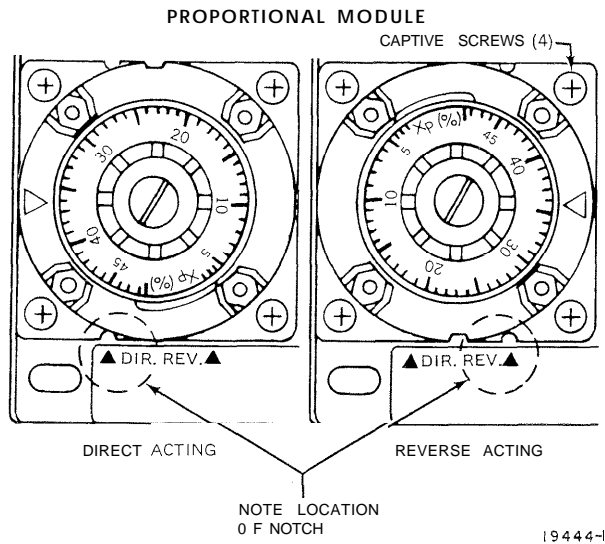

Fig. 15. Changing Controller Action

### NEGATIVE TO POSITIVE COMPENSATION (RP920B and D)

Positive compensation is used for summer compensation or humidity reset applications.

1. Loosen the four screws on the compensation module (Fig. 16).
2. Remove the module. Rotate the module and its gasket 180 degrees and reinstall. Ensure that the notch on the module lines up with the proper indication on the base.
3. Retighten the four screws.
4. If required, recalibrate.

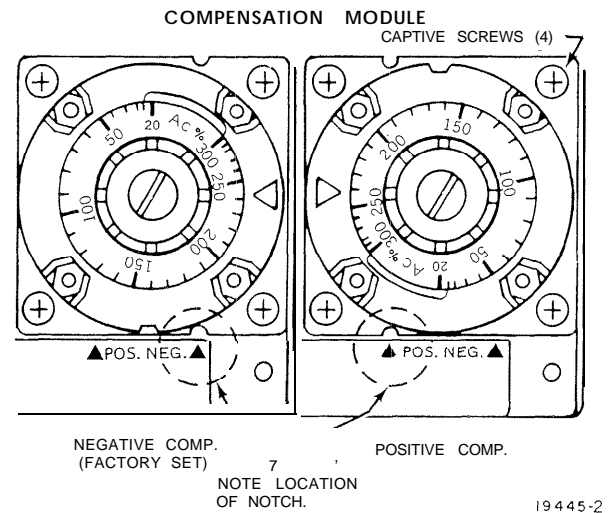

Fig. 16. Changing from Negative to Positive Compensation,

### INTEGRAL ACTION CUT-OFF AND GAGE FUNCTION (RP920C and D)

1. Check the position of the gasket tab (Fig. 17). The position of the gasket located under the switch block module determines the function of the field-installed gage on the switch block module and determines if the integral action cut-off function is enabled or disabled. See Table 2 for factory and field settings.

Table 2. Switch Block Module Gasket Position.

Model	Factory Setting	Field Options
RP920B	B	C
RP920C	B	+B
RP920D	B	C, +C, +B

B = Branch Line Gage  
 C = Compensation Sensor Gage  
 + = Integral Action Cut-Off Enabled

2. Loosen the three screws securing the switch block module and remove the module. Remove the gasket and note the symbols embossed on the back of the module (Fig 17).
3. Rotate and/or flip the gasket until the gasket position matches the functions desired with the desired letter showing from the back of the module.
4. Reinstall the switch block module and tighten the three screws.
5. Connect the integral action cut-off switching components in Ports 6 and 7, if used

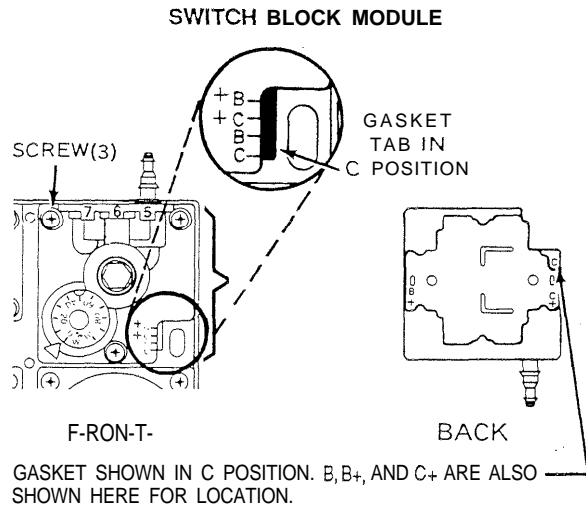

Fig. 17. Integral Action Cut-Off and Gage Function Gasket Position

## SETPOINT ADJUSTMENT

### NOTES:

1. The setpoint knob (W1, Fig 18) is embossed with a 0- to 100-percent scale. Scaleplate overlays are included to match various sensor ranges.
  2. Three methods of setpoint adjustment are available:
    - a. Local Setpoint Adjustment-The setpoint is adjusted directly on the controller.
    - b. Remote Setpoint Adjustment-The setpoint is controlled from 0 to 100 percent of primary sensor span from a remote 3 to 15 psi (21 to 103 kPa) bleed-type switch or controller feeding Port 8. Restricted air is supplied to Port 8 by the controller.
- NOTE: Remote adjustment can be either Remote Setpoint Adjustment or CPA but not both.

- c. Control Point Adjustment (CPA models only)--- The baseline setpoint on the controller can be adjusted  $\pm 15$  percent of the primary sensor span from a remote 3 to 15 psi (21 to 103kPa) signal into Port 8.

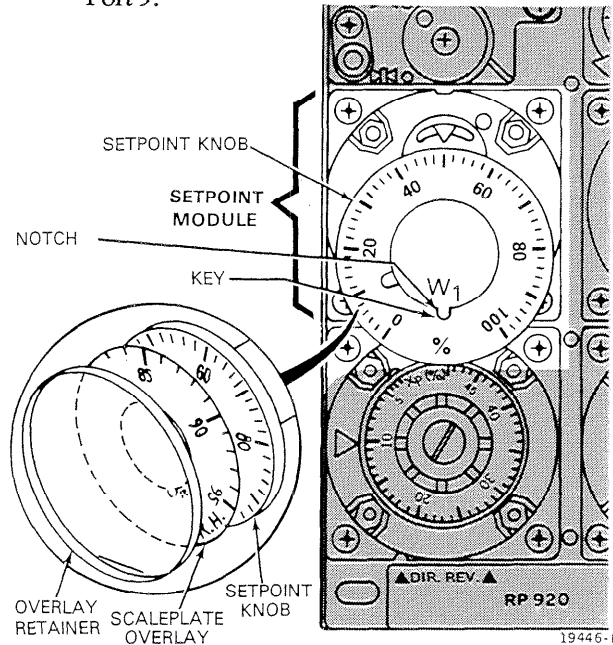

Fig. 18. Setpoint Adjustment.

### LOCAL SETPOINT ADJUSTMENT

See preceding NOTE 2a.

1. If the scale overlay is used, insert the overlay between the setpoint knob and transparent overlay retainer. Note the position of the key and notch.
2. Using the setpoint knob, adjust the setpoint according to the job drawings,
3. Calibrate only if the control point deviates significantly from the setpoint, taking into consideration the throttling range.

### REMOTE SETPOINT ADJUSTMENT

See preceding NOTE 2b,

1. Adjust the setpoint knob to 100 percent or to the maximum desired.
2. Install Barb Fitting 14003755-001 to Port 8 and connect to a bleed-type remote setpoint device (e.g., SP970) and 0- to 30-psi gage,

#### CONTROL POINT ADJUSTMENT (CPA Models Only)

1. Pipe the CPA device to Port 9.  
NOTE: A 1 psi change in the CPA pressure causes a change of 2.5 percent of the primary sensor span.
2. Set the CPA to the center of its range when calibrating controllers. For example: Set the CPA to 9 psi (62 kPa) for a 3- to 15-psi (21 to 103 kPa) signal range.

#### PROPORTIONAL BAND ADJUSTMENT

Adjust the Proportional Band (PB) according to the job drawings with the proportional band adjustment knob (Fig. 14).

$$PB = \frac{\text{Operating Throttling Range}}{\text{Primary Sensor Span}}$$

#### AUTHORITY ADJUSTMENT (RP920B and D)

Adjust the authority according to the job drawings with the authority adjustment knob (Fig. 14). Calculate the authority setting as follows:

Negative compensation:

$$A_c = \frac{SC_s}{SP_s} \times \frac{\Delta SP + TR}{\Delta SC} \times 100$$

Positive compensation:

$$A_c = \frac{SC_s}{SP_s} \times \frac{\Delta SP - TR}{\Delta SC} \times 100$$

Where (in measured variable units):

- A<sub>c</sub> = Authority
- ASC = Compensation sensor operating range
- s c s = Compensation sensor span
- ASP = Primary sensor operating range
- SP<sub>s</sub> = Primary sensor span
- TR = Throttling range in measured variable (use 0 for RP920D)

If the authority is greater than 300 percent or must be calculated using pressure units, see RP920A-D Modular Pneumatic Controller Engineering Data 77-6082.

NOTE: Calibration can cause the actual authority setting to vary from the calculated value.

#### COMPENSATION STARTPOINT ADJUSTMENT (RP920B and D)

Adjust the compensation startpoint according to the job drawings with the compensation startpoint adjustment knob (Fig. 14). If the startpoint is not in percent, convert it to a percentage of the compensation sensor range. See APPENDIX A.

#### RESET TIME ADJUSTMENT (RP920C and D)

Adjust the reset time according to the job drawings with the reset time adjustment knob (Fig. 14). When the system is in operation and stable, decrease the setting a little at a time until the system becomes unstable. Increase the setting slightly until the system becomes stable.

#### COVER

When a cover is used, snap it straight on from the front. The cover is secured by tightening the self-tapping screw in the lower right corner.

# TROUBLESHOOTING

Table 3 lists the problems and solutions in troubleshooting in RP920 Controller,

Table 3. RP920 Problem-Solution Chart.

Problem	Solution
1. When setpoint is changed in both directions, BLP does not reach the minimum of 0.5 psi (3.5 kPa) or maximum of 2 psi (14 kPa) below mainline pressure.	Replace setpoint module and recalibrate,
2. BLP does not react properly or reacts too slowly.	
3. Continuous bleed-off at Port 4.	
4. Air leak at BLP test tap.	Plug with 14002172-001 Gage Tap Repair Plug or renlace connector block module.
5. Setpoint adjustment does not work properly.	Check Port 8 for leaks; if none, replace setpoint module and recalibrate.
6. No setpoint change on change in CPA pressure.	Same as Step 4.
7. When proportional band setting is changed in both directions, BLP does not change.	Replace proportional module and recalibrate.
8. RP920B and D only: When authority setting is changed in both directions, BLP does not change.	Replace compensation module.
9. RP920B and D only: Compensation startpoint cannot be changed by adjustment of compensation startpoint knob.	Replace switch block module (with startpoint prv). Recalibrate if needed.
10. No air is supplied to primary sensor (Port 3) with restriction switch in the unblocked position.	Replace connector block module.
11. Air leaks at Port 3 with restriction switch in blocked position.	Tighten restrictor switch screw or replace connector block module.
12. Air leaks at restrictor switch.	
13. Controller produces unacceptable noise (high frequency humming).	Identify which prv is generating the noise by touching the related adjustment knob or screw until noise changes. If source is setpoint or operating point prv, replace setpoint module. If source is in compensation startpoint prv, renlace switch block. If needed, recalibrate,

# REPAIR

The following repair procedures cover recommended repair for the RP920 as listed in the PARTS AND ACCESSORIES section under PARTS LIST.

NOTE? Before doing any repair on the RP920, shut off system air and disconnect all tubing from ports.

## MODULE REPLACEMENT

1. Remove the module to be replaced, including the gasket, by loosening the screws

2. Install the new gasket and secure the replacement module to the base with the screws.
3. Connect and turn on the system air. Perform the operational check.

## SETPOINT KNOB REPLACEMENT

Simply lift off the setpoint knob and replace it with the new one (Fig.

## FILTER/O-RING REPLACEMENT IN CONNECTOR BLOCK MODULE

1. Loosen the four screws securing the connector block module to the base (Fig. 19).
2. Loosen the screw securing the restrictor switch until the connector block module can be lifted from the base.
3. Remove the screw and restrictor switch (Fig. 20).
4. Using a wire or large paper clip, push through the hole (Fig. 20). The filter and O-ring will fall out.
5. Install the new filter and O-ring.
6. Secure the restrictor switch to the connector block module with the knob on restrictor switch positioned between the two stops.
7. Secure the connector block module with the four screws.

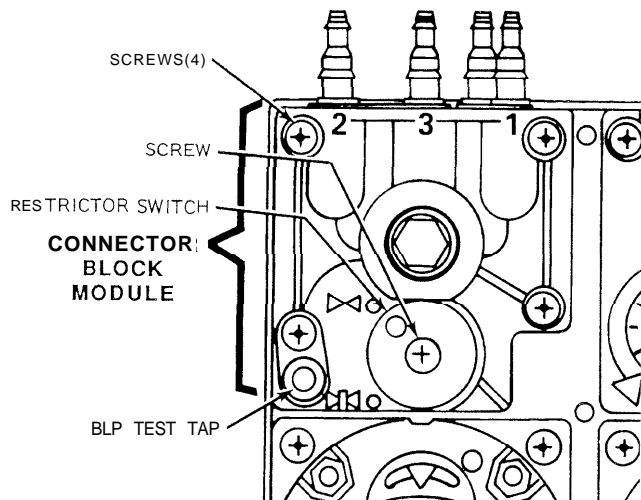

19442-3

Fig. 19. Connector Block Module Parts Identity.

## GAGE SEAL REPLACEMENT

1. Remove the gage or gage plug (Fig. 20) from the connector block module or switch block module.
2. Insert a wire or paper clip into the hole in the center of gage seal and gently pry out the old seal.
3. Insert the new seal, small end down. Use the point of a ball point pen to seat the seal.
4. Replace the gage or gage plug,

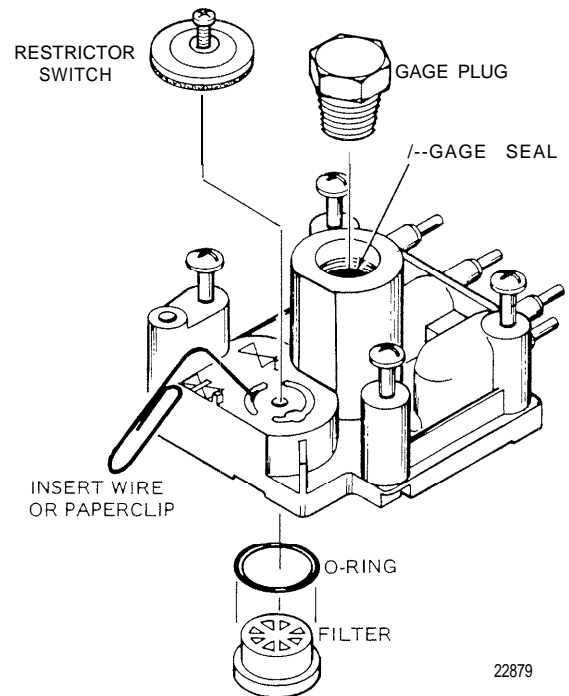

Fig. 20. Filter/O-Ring, Gage Seal Replacement Diagram.

# PARTS AND ACCESSORIES

## PARTS LIST

Table 4. RP920 Parts List (Refer to Fig. 13).

Part No.	Description	Used with
14004276002	Proportional Module w/gasket	All RP920s
14004277-003	Setpoint Module w/gasket and setpoint knob	RP920 w/CPA
14004277-004	Setpoint Module w/gasket and setpoint knob	RP920 w/o CPA
14004278-002	Compensation Module w/gasket	RP920B & D
14004283-002	Switch Block Module w/gasket	RP920B & D
	Includes Gage Seal and Plug	
14004283-003	Switch Block Module w/gasket	RP920C
	Includes Gage Seal and Plug	
14004533-001	Connector Block Module w/gasket	RP920 w/CPA
	Includes Gage Seal and Plug and Port 8 Seal Screw	
14004533-002	Connector Block Module w/gasket	RP920 w/o CPA
	Includes Gage Seal and Plug and Port 8 Seal Screw	
43188083-002	Integral Module w/gasket	RP920C & D
43188059-001	Setpoint Knob—Setpoint Module—(Fig. 18)	All RP920s
14004290-002	Bag Assembly (special metric thread screws)	All RP920s
43 187524-001	Gage Seal—Connector or Switch Block Modules—(Fig. 20)	All RP920s
43915905-1 10	O-Ring for Filter—Connector Block Module—(Fig. 20)	All RP920s
14001865-001	Filter Assembly—Connector Block Module—(Fig. 20)	All RP920s
14002172-001	Gage Tap Repair Plug—Connector Block Module	All RP920s
14003757-001	Seal Screw—Port 8 (includes O-ring)	All RP920s

## ACCESSORIES

- Add-On Barb Fitting 14003755-001.
- Gage 305965 (0 to 30 psi).
- Gage Adaptor 315161A with plug-in fittings.
- Receiver Gage to match primary sensor (see Pneumatic Indication, Receiver, and Target Gages Specification Data 77-609 1).
- Controller Calibration Kit 816A.
- Cover (Clear Plastic):  
43188057-010-RP920A.  
43188123-010--RP920B, C, and D.
- Temperature, humidity, dewpoint, and cooler-warmer setpoint scales 14004267-001.
- Static pressure setpoint scales 14004267-002.
- Rail mounting bag assembly (25 sets) 14004322-001.

## APPENDIX A

Table 5. Sensor Value to Pressure or Percent of Span Conversion Chart.

% Span	psi (kpa)	Humidity Sensors			LP914			LP915A			TP925, TP974	TP925 Dew-probe
		%RH			deg F (deg C)			1077	1085			
		65/95	15/85	15/75	-40/160 (-40/71)	40/240 (5/115)	-20/80 (-30/30)	0/200 (-18/93)	25/125 (-4/52)	25/125 (-4/52)	50/100 (10/38)	103/153
0	3 (20.68)	65	15	15	-40 (-40.00)	40 (4.44)	-20 (-28.89)	—	—	30 (-1.11)	50 (10.00)	103
1	3.12 (21.51)	65.4	15.8	15.8	-38 (-38.89)	42 (5.56)	-19 (-28.33)	—	—	30.9 (-0.61)	50.5 (10.28)	103.5
2	3.24 (22.34)	65.8	16.5	16.5	-36 (-37.78)	44 (6.67)	-18 (-27.78)	—	—	31.8 (-0.11)	51 (10.56)	104
3	3.36 (23.17)	66.2	17.3	17.3	-34 (-36.67)	46 (7.78)	-17 (-27.22)	—	25 (-3.89)	32.7 (0.39)	51.5 (10.83)	104.5
4	3.48 (23.99)	66.6	18.1	18	-32 (-35.56)	48 (8.89)	-16 (-26.67)	0 (-17.78)	26.3 (-3.17)	33.6 (0.89)	52 (11.11)	105



Table 5. Sensor Value to Pressure or Percent of Span Conversion Chart. (Continued)

% Span	psi (kpa)	Humidity Sensors			LP914			LP915A			TP925, TP974	TP925 Dew-probe
		%RH			deg F (deg C)						deg F	
		65/95	15/85	15/75	-40/160 (-40/71)	40/240 (5/115)	-20/80 (-30/30)	0/200 (-18/93)	25/125 (-4/52)	25/125 (-4/52)	50/100 (10/38)	103/153
5	3.6 (24.82)	67	18.8	18.8	-30 (-34.44)	50 (10.00)	-15 (-26.11)	2.5 (-16.39)	27.5 (-2.50)	34.5 (1.39)	52.5 (11.39)	105.5
6	3.72 (25.65)	67.4	19.6	19.5	-28 (-33.33)	52 (11.11)	-14 (-25.56)	5 (-15.00)	28.8 (-1.78)	35.5 (1.94)	53 (11.67)	106
7	3.84 (26.48)	67.8	20.4	20.3	-26 (-32.22)	54 (12.22)	-13 (-25.00)	7.5 (-13.61)	30 (-1.11)	36.4 (2.44)	53.5 (11.94)	106.5
8	3.96 (27.30)	68.2	21.2	21	-24 (-31.11)	56 (13.33)	-12 (-24.44)	10 (-12.22)	31.1 (-0.50)	37.3 (2.94)	54 (12.22)	107
9	4.08 (28.13)	68.6	21.9	21.8	-22 (-30.00)	58 (14.44)	-11 (-23.89)	12.5 (-10.83)	32.2 (0.11)	38.2 (3.44)	54.5 (12.50)	107.5
10	4.2 (28.96)	68.9	22.7	22.5	-20 (-28.89)	60 (15.56)	-10 (-23.33)	15 (-9.44)	33.3 (0.72)	39.9 (4.39)	55 (12.78)	108
11	4.32 (29.79)	69.3	23.5	23.3	-18 (-27.78)	62 (16.67)	-9 (-22.78)	17.5 (-8.06)	34.4 (1.33)	40 (4.44)	55.5 (13.06)	108.5
12	4.44 (30.61)	69.7	24.2	24	-16 (-26.67)	64 (17.78)	-8 (-22.22)	20 (-6.67)	35.6 (2.00)	40.8 (4.89)	56 (13.33)	109
13	4.56 (31.44)	70.1	25	24.8	-14 (-25.56)	66 (18.89)	-7 (-21.67)	22.5 (-5.28)	36.7 (2.61)	41.7 (5.39)	56.5 (13.61)	109.5
14	4.68 (32.27)	70.5	25.8	25.5	-12 (-24.44)	68 (20.00)	-6 (-21.11)	25 (-3.89)	37.8 (3.22)	42.8 (6.00)	57 (13.89)	110
15	4.8 (33.10)	70.9	26.5	26.3	-10 (-23.33)	70 (21.11)	-5 (-20.56)	27.1 (-2.72)	38.9 (3.83)	43.3 (6.28)	57.5 (14.17)	110.5
16	4.92 (33.92)	71.3	27.3	27	-8 (-22.22)	72 (22.22)	-4 (-20.00)	29.3 (-1.50)	40 (4.44)	44.2 (6.78)	58 (14.44)	111
17	5.04 (34.75)	71.7	28.1	27.8	-6 (-21.11)	74 (23.33)	-3 (-19.44)	31.4 (-0.33)	41 (5.00)	45 (7.22)	58.5 (14.72)	111.5
18	5.16 (35.58)	72.1	28.8	28.5	-4 (-20.00)	76 (24.44)	-2 (-18.89)	33.6 (0.89)	42 (5.56)	45.8 (7.67)	59 (15.00)	112
19	5.28 (36.40)	72.5	29.6	29.3	-2 (-18.89)	78 (25.56)	-1 (-18.33)	35.7 (2.06)	43 (6.11)	46.7 (8.17)	59.5 (15.28)	112.5
20	5.4 (37.23)	72.9	30.4	30	0 (-17.78)	80 (26.67)	0 (-17.78)	37.9 (3.28)	44 (6.67)	47.5 (8.61)	60 (15.56)	113
21	5.52 (38.06)	73.8	31.2	30.8	2 (-16.67)	82 (27.78)	1 (-17.22)	40 (4.44)	45 (7.22)	48.3 (9.06)	60.5 (15.83)	113.5
22	5.64 (38.89)	73.7	31.9	31.5	4 (-15.56)	84 (28.89)	2 (-16.67)	42.2 (5.67)	46 (7.78)	49.2 (9.56)	61 (16.11)	114
23	5.76 (39.71)	74.1	32.7	32.3	6 (-14.44)	86 (30.00)	3 (-16.11)	44.4 (6.89)	47 (8.33)	50 (10.00)	61.5 (16.39)	114.5
24	5.88 (40.54)	74.5	33.5	33	8 (-13.33)	88 (31.11)	4 (-15.56)	46.7 (8.17)	48 (8.89)	50.9 (10.50)	62 (16.67)	115
25	6 (41.37)	74.9	34.2	33.8	10 (-12.22)	90 (32.22)	5 (-15.00)	48.9 (9.39)	49 (9.44)	51.8 (11.00)	62.5 (16.94)	115.5
26	6.12 (42.20)	75.3	35	34.5	12 (-11.11)	92 (33.33)	6 (-14.44)	51.1 (10.61)	50 (10.00)	52.7 (11.50)	63 (17.22)	116
27	6.24 (43.02)	75.7	35.8	35.3	14 (-10.00)	94 (34.44)	7 (-13.89)	53.3 (11.83)	51.1 (10.61)	53.6 (12.00)	63.5 (17.50)	116.5
28	6.36 (43.85)	76.1	36.5	36	16 (-8.89)	96 (35.56)	8 (-13.33)	55.6 (13.11)	52.2 (11.22)	54.5 (12.50)	64 (17.78)	117
29	6.48 (44.68)	76.4	37.3	36.8	18 (-7.78)	98 (36.67)	9 (-12.78)	57.8 (14.33)	53.3 (11.83)	55.5 (13.06)	64.5 (18.06)	117.5
30	6.6 (45.51)	76.8	38.1	37.5	20 (-6.67)	100 (37.78)	10 (-12.22)	60 (15.56)	54.4 (12.44)	56.4 (13.56)	65 (18.33)	118

% Span	psi (kpa)	Humidity Sensors			LP914			LP915A			TP925, TP974	TP925 Dew-probe	
		%RH			deg F (deg C)								
		65/95	15/85	15/75	-40/160 (-40/71)	40/240 (5/115)	-20/80 (-30/30)	0/200 (-18/93)	25/125 (-4/52)	25/125 (-4/52)	50/100 (10/38)	103/153	
													deg F
31	6.72 (46.33)	77.2	38.8	38.3	22 (-5.56)	102 (38.89)	11 (-11.67)	62.1 (16.72)	55.6 (13.11)	57.3 (14.06)	65.5 (18.61)	118.5	
32	6.84 (47.16)	77.6	39.6	39	24 (-4.44)	104 (40.00)	12 (-11.11)	64.3 (17.94)	56.7 (13.72)	58.2 (14.56)	66 (18.89)	119	
33	6.96 (47.99)	78	40.4	39.8	26 (-3.33)	106 (41.11)	13 (-10.56)	66.4 (19.11)	57.8 (14.33)	59.1 (15.06)	66.5 (19.17)	119.5	
34	7.08 (48.82)	78.4	41.2	40.5	28 (-2.22)	108 (42.22)	14 (-10.00)	68.6 (20.33)	58.9 (14.94)	60 (15.56)	67 (19.44)	120	
35	7.2 (49.64)	78.8	41.9	41.3	30 (-1.11)	110 (43.33)	15 (-9.44)	70.7 (21.50)	60 (15.56)	60.9 (16.06)	67.5 (19.72)	120.5	
36	7.32 (50.47)	79.2	42.7	42	32 (0.00)	112 (44.44)	16 (-8.89)	72.9 (22.72)	61.1 (16.17)	61.8 (16.56)	68 (20.00)	121	
37	7.44 (51.30)	79.6	43.5	42.8	34 (1.11)	114 (45.56)	17 (-8.33)	75 (23.89)	62.2 (16.78)	62.7 (17.06)	68.8 (20.44)	121.5	
38	7.56 (52.12)	80	44.2	43.5	36 (2.22)	116 (46.67)	18 (-7.78)	76.7 (24.83)	63.3 (17.39)	63.6 (17.56)	69 (20.56)	122	
39	7.68 (52.95)	80.2	45	44.3	38 (3.33)	118 (47.78)	19 (-7.22)	78.3 (25.72)	64.4 (18.00)	64.5 (18.06)	69.5 (20.83)	122.5	
40	7.8 (53.78)	80.5	45.7	45	40 (4.44)	120 (48.89)	20 (-6.67)	80 (26.67)	65.6 (18.67)	65.5 (18.61)	70 (21.11)	123	
41	7.92 (54.61)	80.7	46.3	45.5	42 (5.56)	122 (50.00)	21 (-6.11)	82.2 (27.89)	66.7 (19.28)	66.4 (19.11)	70.5 (21.39)	123.5	
42	8.04 (55.43)	81	47	46	44 (6.67)	124 (51.11)	22 (-5.56)	84.4 (29.11)	67.8 (19.89)	67.3 (19.61)	71 (21.67)	124	
43	8.16 (56.26)	81.2	47.6	46.5	46 (7.78)	126 (52.22)	23 (-5.00)	86.7 (30.39)	68.9 (20.50)	68.2 (20.11)	71.5 (21.94)	124.5	
44	8.28 (57.09)	81.3	48.3	47	48 (8.89)	128 (53.33)	24 (-4.44)	88.9 (31.61)	70 (21.11)	69.1 (20.61)	72 (22.22)	125	
45	8.4 (57.92)	81.7	48.9	47.5	50 (10.00)	130 (54.44)	25 (-3.89)	91.1 (32.83)	71 (21.67)	70 (21.11)	72.5 (22.50)	125.5	
46	8.52 (58.74)	81.9	49.6	48	52 (11.11)	132 (55.56)	26 (-3.33)	93.3 (34.06)	72 (22.22)	71 (21.67)	73 (22.78)	126	
47	8.64 (59.57)	82.2	50.2	48.5	54 (12.22)	134 (56.67)	27 (-2.78)	95.6 (35.33)	73 (22.78)	72 (22.22)	73 (23.06)	126.5	
48	8.76 (60.40)	82.4	50.9	49	56 (13.33)	136 (57.78)	28 (-2.22)	97.8 (36.56)	74 (23.33)	73 (22.78)	74 (23.33)	127	
49	8.88 (61.23)	82.7	51.6	49.5	58 (14.44)	138 (58.89)	29 (-1.67)	100 (37.78)	75 (23.89)	74 (23.33)	74.5 (23.61)	127.5	
50	9 (62.05)	82.9	52.2	50	60 (15.56)	140 (60.00)	30 (-1.11)	102 (38.89)	76 (24.44)	75 (23.89)	75 (23.89)	128	
51	9.12 (62.88)	83.1	52.9	50.5	62 (16.67)	142 (61.11)	31 (-0.56)	104 (40.00)	77 (25.00)	75.8 (24.33)	75.5 (24.17)	128.5	
52	9.24 (63.71)	83.4	53.5	51	64 (17.78)	144 (62.22)	32 (0.00)	106 (41.11)	78 (25.56)	76.7 (24.83)	76 (24.44)	129	
53	9.36 (64.54)	83.6	54.2	51.5	66 (18.89)	146 (63.33)	33 (0.56)	108 (42.22)	79 (26.11)	77.5 (25.28)	76.5 (24.72)	129.5	
54	9.48 (65.36)	83.9	54.8	52	68 (20.00)	148 (64.44)	34 (1.11)	110 (43.33)	80 (26.67)	78.3 (25.72)	77 (25.00)	130	
55	9.6 (66.19)	84.1	55.5	52.5	70 (21.11)	150 (65.56)	35 (1.67)	112 (44.44)	81 (27.22)	79.2 (26.22)	77.5 (25.28)	130.5	
56	9.72 (67.02)	84.4	56.1	53	72 (22.22)	152 (66.67)	36 (2.22)	114 (45.56)	82 (27.78)	80 (26.67)	78 (25.56)	131	

% Span	psi (kpa)	Humidity Sensors			LP914			LP915A			TP925, TP974	TP925 Dew-probe
		%RH			deg F (deg C)							
		65/95	15/85	15/75	-40/160 (-40/71)	40/240 (5/115)	-20/80 (-30/30)	0/200 (-18/93)	25/125 (-4/52)	25/125 (-4/52)	50/100 (10/38)	103/153
		deg F										
57	9.74 (67.16)	84.6	56.8	53.5	74 (23.33)	154 (67.78)	37 (2.78)	116 (46.67)	83 (28.33)	81 (27.22)	78.8 (26.00)	131.5
58	9.96 (68.67)	84.8	57.5	54	76 (24.44)	156 (68.89)	38 (3.33)	118 (47.78)	84 (28.89)	82 (27.78)	79 (26.11)	132
59	10.08 (69.50)	85.1	58.1	54.5	78 (25.56)	158 (70.00)	39 (3.89)	120 (48.89)	85 (29.44)	83 (28.33)	79.5 (26.39)	132.5
60	10.2 (70.33)	85.3	58.8	55	80 (26.67)	160 (71.11)	40 (4.44)	121.8 (49.89)	86 (30.00)	84 (28.89)	80 (26.67)	133
61	10.32 (71.15)	85.6	59.4	55.5	82 (27.78)	162 (72.22)	41 (5.00)	123.6 (50.89)	87 (30.56)	85 (29.44)	80.5 (26.94)	133.5
62	10.44 (71.98)	85.8	60.1	56	84 (28.89)	164 (73.33)	42 (5.56)	125.5 (51.94)	88 (31.11)	86 (30.00)	81 (27.22)	134
63	10.56 (72.81)	86	60.7	56.5	86 (30.00)	166 (74.44)	43 (6.11)	127.3 (52.94)	89 (31.67)	87 (30.56)	81.5 (27.50)	134.5
64	10.68 (73.64)	86.3	61.4	57	88 (31.11)	168 (75.56)	44 (6.67)	129.1 (53.94)	90 (32.22)	88 (31.11)	82 (27.78)	135
65	10.8 (74.46)	86.5	62	57.5	90 (32.22)	170 (76.67)	45 (7.22)	130.9 (54.94)	91 (32.78)	89 (31.67)	82.5 (28.06)	135.5
66	10.92 (75.29)	86.8	62.7	58	92 (33.33)	172 (77.78)	46 (7.78)	132.7 (55.94)	92 (33.33)	90 (32.22)	83 (28.33)	136
67	11.04 (76.12)	87	63.4	58.5	94 (34.44)	174 (78.89)	47 (8.33)	134.5 (56.94)	93 (33.89)	90.9 (32.72)	83.5 (28.61)	136.5
68	11.16 (76.95)	87.3	64	59	96 (35.56)	176 (80.00)	48 (8.89)	136.4 (58.00)	94 (34.44)	91.8 (33.22)	84 (28.89)	137
69	11.28 (77.77)	87.5	64.7	59.5	98 (36.67)	178 (81.11)	49 (9.44)	138.2 (59.00)	95 (35.00)	92.7 (33.72)	84.5 (29.17)	137.5
70	11.4 (78.60)	87.7	65.3	60	100 (37.78)	180 (82.22)	50 (10.00)	140 (60.00)	96 (35.56)	93.3 (34.06)	85 (29.44)	138
71	11.52 (79.43)	88	66	60.5	102 (38.89)	182 (83.33)	51 (10.56)	141.8 (61.00)	97 (36.11)	94.5 (34.72)	85.5 (29.72)	138.5
72	11.64 (80.26)	88.2	66.6	61	104 (40.00)	184 (84.44)	52 (11.11)	143.6 (62.00)	98 (36.67)	95.5 (35.28)	86 (30.00)	139
73	11.76 (81.08)	88.5	67.3	61.5	106 (41.11)	186 (85.56)	53 (11.67)	145.5 (63.06)	99 (37.22)	96.4 (35.78)	86.5 (30.28)	139.5
74	11.88 (81.91)	88.7	68	62	108 (42.22)	188 (86.67)	54 (12.22)	147.3 (64.06)	100 (37.78)	97.3 (36.28)	87 (30.56)	140
75	12 (82.74)	89	68.6	62.5	110 (43.33)	190 (87.78)	55 (12.78)	149.1 (65.06)	101 (38.33)	98.2 (36.78)	87.5 (30.83)	140.5
76	12.12 (83.56)	89.2	69.3	63	112 (44.44)	192 (88.89)	56 (13.33)	150.9 (66.06)	102 (38.89)	99.1 (37.28)	88 (31.11)	141
77	12.24 (84.39)	89.4	69.9	63.5	114 (45.56)	194 (90.00)	57 (13.89)	152.7 (67.06)	103 (39.44)	100 (37.78)	88.5 (31.39)	141.5
78	12.36 (85.22)	89.7	70.6	64	116 (46.67)	196 (91.11)	58 (14.44)	154.5 (68.06)	104 (40.00)	101 (38.33)	89 (31.67)	142
79	12.48 (86.05)	90	71.2	64.5	118 (47.78)	198 (92.22)	59 (15.00)	156.4 (69.11)	105 (40.56)	102 (38.89)	89.5 (31.94)	142.5
80	12.6 (86.87)	90.2	71.9	65	120 (48.89)	200 (93.33)	60 (15.56)	158.2 (70.11)	106 (41.11)	103 (39.44)	90 (32.22)	143
81	12.72 (87.70)	90.4	72.5	65.5	122 (50.00)	202 (94.44)	61 (16.11)	160 (71.11)	107 (41.67)	104 (40.00)	90.5 (32.50)	143.5
82	12.84 (88.53)	90.6	73.2	66	124 (51.11)	204 (95.56)	62 (16.67)	161.8 (72.11)	108 (42.22)	105 (40.56)	91 (32.78)	144

% Span	psi (kpa)	Humidity Sensors			LP914			LP915A			TP925, TP974	TP925 Dew-probe
		65/95	15/85	15/75	-40/160 (-40/71)	40/240 (5/115)	-20/80 (-30/30)	1077	1085	50/100 (10/38)		
								deg F (deg C)				
83	12.96 (89.36)	90.9	73.9	66.5	126 (52.22)	206 (96.67)	63 (17.22)	163.6 (73.11)	109 (42.78)	106 (41.11)	91.5 (33.06)	144.5
84	13.08 (90.18)	91.1	74.5	67	128 (53.33)	208 (97.78)	64 (17.78)	165.5 (74.17)	110 (43.33)	107 (41.67)	92 (33.33)	145
85	13.2 (91.01)	91.4	75.2	67.5	130 (54.44)	210 (98.89)	65 (18.33)	167.3 (75.17)	111 (43.89)	108 (42.22)	92.5 (33.61)	145.5
86	13.32 (91.84)	91.6	75.8	68	132 (55.56)	212 (100.00)	66 (18.89)	169.1 (76.17)	112 (44.44)	109 (42.78)	93 (33.89)	146
87	13.44 (92.67)	91.9	76.5	68.5	134 (56.67)	214 (101.11)	67 (19.44)	170.9 (77.17)	113 (45.00)	110 (43.33)	93.5 (34.17)	146.5
88	13.56 (93.49)	92.1	77.1	69	136 (57.78)	216 (102.22)	68 (20.00)	172.7 (78.17)	114 (45.56)	110.9 (43.83)	94 (34.44)	147
89	13.68 (94.32)	92.3	77.8	69.5	138 (58.89)	218 (103.33)	69 (20.56)	174.5 (79.17)	115 (46.11)	111.8 (44.33)	94.5 (34.72)	147.5
90	13.8 (95.15)	92.6	78.4	70	140 (60.00)	220 (104.44)	70 (21.11)	176.4 (80.22)	116 (46.67)	112.7 (44.83)	95 (35.00)	148
91	13.92 (95.98)	92.8	79.1	70.5	142 (61.11)	222 (105.56)	71 (21.67)	178.2 (81.22)	117 (47.22)	113.6 (45.33)	95.5 (35.28)	148.5
92	14.04 (96.80)	93.1	79.8	71	144 (62.22)	224 (106.67)	72 (22.22)	180 (82.22)	118 (47.78)	114.5 (45.83)	96 (35.56)	149
93	14.16 (97.63)	93.3	80.4	71.5	146 (63.33)	226 (107.78)	73 (22.78)	181.7 (83.17)	119 (48.33)	115.5 (46.39)	96.5 (35.83)	149.5
94	14.28 (98.46)	93.5	81.1	72	148 (64.44)	228 (108.89)	74 (23.33)	183.3 (84.06)	120 (48.89)	116.4 (46.89)	97 (36.11)	150
95	14.4 (99.29)	93.8	81.7	72.5	150 (65.56)	230 (110.00)	75 (23.89)	185 (85.00)	121 (49.44)	117.3 (47.39)	97.5 (36.39)	150.5
96	14.52 (100.11)	94	82.4	73	152 (66.67)	232 (111.11)	76 (24.44)	186.7 (85.94)	122 (50.00)	118.2 (47.89)	98 (36.67)	151
97	14.64 (100.94)	94.3	83	73.5	154 (67.78)	234 (112.22)	77 (25.00)	188.3 (86.83)	123 (50.56)	119.1 (48.39)	98.5 (36.94)	151.5
98	14.76 (101.77)	94.5	83.7	74	156 (68.89)	236 (113.33)	78 (25.56)	190 (87.78)	124 (51.11)	120 (48.89)	99 (37.22)	152
99	14.88 (102.59)	94.8	84.3	74.5	158 (70.00)	238 (114.44)	79 (26.11)	191.7 (88.72)	125 (51.67)	121 (49.44)	99.5 (37.50)	152.5
100	15 (103.42)	95	85	75	160 (71.11)	240 (115.56)	80 (26.67)	193.3 (89.61)	—	122 (50.00)	100 (37.78)	153
101	15.12 (104.25)	—	—	—	—	—	—	195 (90.56)	—	123 (50.56)	—	—
102	15.24 (105.08)	—	—	—	—	—	—	196.7 (91.50)	—	124 (51.11)	—	—
103	15.36 (105.90)	—	—	—	—	—	—	198.3 (92.39)	—	125 (51.67)	—	—
104	15.48 (106.73)	—	—	—	—	—	—	200 (93.33)	—	—	—	—



## UNITED STATES

### ALABAMA

BIRMINGHAM  
205/645-3562

MOBILE  
205/344-1583

### ALASKA

ALASKA  
907/564-8120

### ARIZONA

PHOENIX  
800/367-4757

### ARKANSAS

LITTLE ROCK  
501/664-0070  
800/482-8380

### CALIFORNIA

IRVINE  
800/367-4757

LOS ANGELES  
213/726-6161  
800/367-4757

SACRAMENTO  
916/923-7820

SAN DIEGO  
800/367-4757

SAN FRANCISCO  
415/550-2038

SAN JOSE  
408/433-3082

### COLORADO

DENVER  
303/792-1503

### CONNECTICUT

HARTFORD  
203/659-4011

### DELAWARE

WILMINGTON  
302/222-8585

### FLORIDA

JACKSONVILLE  
904/396-6971

MIAMI  
305/364-2368

ORLANDO  
407/897-7216

TAMPA  
813/882-6000

### GEORGIA

ATLANTA  
404/982-2495

### HAWAII

HONOLULU  
808/537-5514

### ILLINOIS

CHICAGO DOWNTOWN  
312/524-8181

CHICAGO NORTH  
312/982-6632

CHICAGO SOUTH  
312/568-4200

ELGW  
312/697-7880

PEORIA  
309/686-6464

### INDIANA

FORT WAYNE  
219/482-9654

INDIANAPOLIS  
317/243-0831

### IOWA

DAVENPORT  
319/359-3441

DES MOINES  
515/288-3601

### KANSAS

WICHITA  
800/14455546

### KENTUCKY

LOUISVILLE  
502/429-4326

### LOUISIANA

BATON ROUGE  
800/228-7905

NEW ORLEANS  
504/456-7232

SHREVEPORT  
214/387-5467

### MAINE

PORTLAND, ME  
207/775-3501  
800/356-2117

### MARYLAND

BALTIMORE  
301/771-3000 x247

### MASSACHUSETTS

BOSTON  
617/969-0250

### MICHIGAN

DETROIT  
313/473-5041

GRAND RAPIDS  
616/12474811

SAGINAW  
517/777-928707

### MINNESOTA

TWIN CITY  
612/630-3820

612/630-3880

### MINNESOTA

612/690-6801

### MISSISSIPPI

JACKSON  
800/843-8435

### MISSOURI

KANSAS CITY  
816/358-4200

ST. LOUIS  
314/569-5429

### NEBRASKA

OMAHA  
402/331-3329

### NEVADA

LAS VEGAS  
800/367-4757

NORTHERN NEVADA  
916/485-2221

916/923-7800  
800/824-2286

### NEW HAMPSHIRE

NEW HAMPSHIRE  
800/356-2117

### NEW JERSEY

MT. LAUREL  
609/596-4900

PARSIPPANY  
201/263-2881

WESTFIELD  
201/2351245

### NEW MEXICO

ALBUQUERQUE  
800/367-4757

### NEW YORK

ALBANY  
518/456-7000

BUFFALO  
716/689-0200

LONG ISLAND  
516/496-2300

718/347-3435

NEW YORK CITY  
718/392-4300

ROCHESTER  
716/272-4339

SYRACUSE  
315/451-4000

WHITE PLAINS  
914/582-2990

212/220-2213

### NORTH CAROLINA

CHARLOTTE  
704/364-4770

GREENSBORO  
919/294-9230

800/632-0354

RALEIGH  
800/632-0354

### NORTH DAKOTA

FARGO  
701/235-4221

### OHIO

AKRON  
216/867-6507

CINCINNATI  
513/745-7131

CLEVELAND  
216/459-6057

COLUMBUS  
614/287-2210

DAYTON  
513/237-4035

TOLEDO  
419/473-8721

### OKLAHOMA

OKLAHOMA CITY  
405/849-2811

TULSA  
918/438-0187

### OREGON

PORTLAND, OR  
503/526-5140

### PENNSYLVANIA

HARRISBURG  
717/561-7024

PHILADELPHIA METRO  
215/1668302

PITTSBURGH  
412/928-4235

VALLEY Forge  
215/666-8281

WILKES-BARRE  
717/654-2477

### RHODE ISLAND

PROVIDENCE  
401/438-6000

### SOUTH CAROLINA

COLUMBIA  
803/798-4477

### SOUTH DAKOTA

SIOUX FALLS  
605/336-0966

### TENNESSEE

MEMPHIS  
901/345-6222

800/222-9193

NASHVILLE  
615/13853400

### TEXAS

AUSTIN  
512/14751788

DALLAS  
214/387-5467

EL PASO  
800/367-4757

FORT WORTH  
214/387-5467

HOUSTON  
713/780-6609

LUBBOCK  
806/777-4757

SAN ANTONIO  
512/341-4681

### UTAH

SALT LAKE CITY  
801/483-8109

800/237-8839

### VIRGINIA

RICHMOND  
804/289-6269

ROANOKE  
804/289-6269

VIRGINIA BEACH  
804/461-0264

### WASHINGTON

SEATTLE  
206/236-4030

SPOKANE  
509/534-5022

### WASHINGTON, D.C.

WASHINGTON, D.C.  
703/749-2017

### WEST VIRGINIA

CHARLESTON  
304/766-8000

800/543-7810 (WV)  
800/533-1619 (KY)

CLARKSBURG  
304/642-7353

800/543-7810 (WV)  
800/533-1619 (OH)

### WISCONSIN

APPLETON  
414/733-4491

MADISON  
608/276-3131

MILWAUKEE  
414/784-6260

### WYOMING

CASPER  
307/779-6295

## CANADA

### ALBERTA

CALGARY  
403/255-5554

EDMONTON  
403/483-4727

### BRITISH COLUMBIA

BURNABY  
604/291-6631

VICTORIA  
604/386-6644

### MANITOBA

WINNIPEG  
204/753-4545

### NEW BRUNSWICK

MONCTON  
506/857-8890

### NEWFOUNDLAND

ST. JOHN'S  
709/722-2436

### NOVA SCOTIA

DARTMOUTH  
902/465-2400

### ONTARIO

HAMILTON  
416/561-9631

LONDON  
519/16852010

519/823-4486

NORTH YORK  
416/491-1300

### OTTAWA

613/224-3822

SUDBURY  
705/566-6731

WINDSOR  
519/969-5840

### QUEBEC

SAINT-FOY  
418/18883320

VERDUN  
514/17659355

### SASKATCHEWAN

REGINA  
306/347-0888

SASKATOON  
306/563-0856

# Honeywell

## Home and Building Control

Honeywell Inc.

Honeywell Plaza

P.O. Box 524

Minneapolis, MN 55408-0524

## Home and Building Control

Honeywell Limited-Honeywell Limitée

740 Ellesmere Road

Scarborough, Ontario

M1P 2V9

*Helping You Control Your World*