

## T6380 Series Electronic Fan Coil Thermostats

PRODUCT DATA

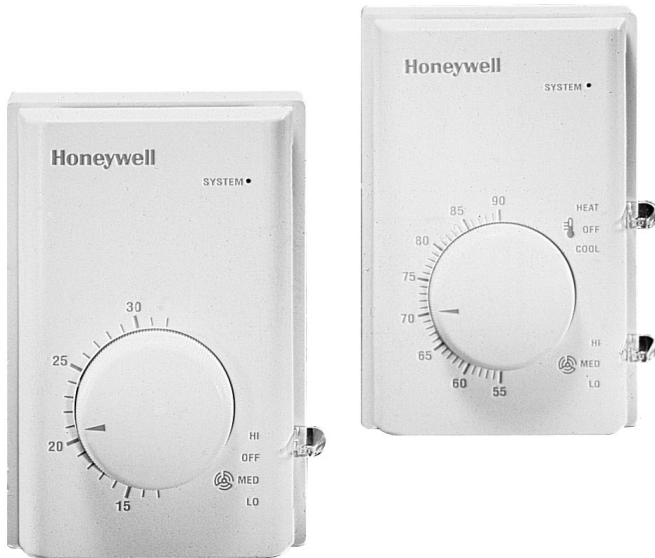

### APPLICATION

The T6380 series of electronic fan coil thermostats provide precision line voltage control of fan-forced Heating, Ventilating and Air Conditioning equipment. Models are available for cooling-only, manual heat-cool changeover, or remote heat-cool changeover systems. Hydronic source heat-cool systems may be two or four-pipe configuration with 0, 1, or 2 valves. Fan control options include constant, cycled, or user-selectable "On-Auto" operation. Manual fan speed selection is standard. All models feature an "Off" switch.

### FEATURES

- Electronic temperature sensing provides energy-efficient, precision operation for maximum comfort.
- Contemporary white sculpted styling.
- Vertical or horizontal mounting configurations.
- Adjustment ranges 55° to 90°F or 13° to 32°C.
- Easy-to-use set point knob.
- LED system status indicator. "OFF" de-energizes all connected loads.
- Three level fan speed selection.
- Constant, cycled, or on-auto selectable fan operation available.
- Models for manual or remote heat-cool changeover, heating-only, or cooling-only systems.
- Models for 2 or 4-pipe systems.
- Rugged molded thermoplastic housing with captive mounting screws, mounts on single-gang NEMA-standard (U.S.) electrical box.
- Screw terminal block connections.
- Suitable for inductive-rated loads such as valves, relays, contactors and fans.
- Range stops and cover locking kit available.
- UL Listed. CSA Certified.

### Contents

Specifications .....	2
Ordering Information .....	2
Installation .....	3
Wiring .....	3
Operations .....	5
Check-out .....	5

# SPECIFICATIONS

MODELS: Fan Coil System	3-Speed Fan Operation		
	Constant	Cycled	On-Auto
2-pipe System • Cooling only	T6383A Fig. 2a	T6381A Fig. 5a	T6387A Fig. 8a
	T6383A Fig. 2b	T6381A Fig. 5b	T6387A Fig. 8a
2-pipe Heat-Cool • Manual Change/Over	T6383B Fig. 3	T6381B Fig. 6	N/A
	T6383A Fig. 2c	T6381A Fig. 5c	T6387A Fig. 8c
	T6383B Fig. 4b	T6381B Fig. 7b	N/A
• Seasonal, auto C/O			
• Seasonal, auto C/O with aux. electric heat			
4-pipe Heat-Cool • Manual C/O	T6383B Fig. 4a	T6381B Fig. 7a	N/A

### Electrical Ratings:

T6380 Series - Power Supply: 110-130 or 208-277 Vac  
+10/-15%, 50-60 Hz.

T6381, T6387 - Output Rating, cycled ("Auto") fan control

	120 V	208 V	230 V	277 V
50-60 Hz				
Full Load Amps*	3.8	2.1	1.9	1.6
Locked Rotor	22.8	12.6	11.4	9.5
Pilot Duty		125 VA		

\* Equivalent to NEMA 1/8 horsepower rating for a hermetically-sealed motor such as a compressor. Allowable connected load must be determined by adding nameplate full load and locked rotor (inrush) ratings of all loads.

T6383 – Output Rating, constant fan operation

Thermostat (Heat and Cool outputs):

	120 V	208 V	230 V	277 V
50-60 Hz				
Full Load Amps	3.8	2.1	1.9	1.6
Locked Rotor A	22.8	12.6	11.4	9.5
Pilot Duty		125 VA		
Resistive (heat only)	10.0 A	N/A	N/A	5.6

Fan (Air Handler):

	110-130V	208 V	220-240V	277 V
50-60 Hz				
Full Load Amps**	5.8	3.2	2.9	2.4
Locked Rotor	34.8	19.2	17.4	14.4

\*\* Equivalent to NEMA 1/4 horsepower rating for a hermetically-sealed motor. Allowable load must be determined from fan nameplate ratings .

† North American national electrical codes require all ungrounded conductors to electric resistance heating to be broken at the thermostat OFF setting. The 208V and 230V resistive ratings are not UL approved. The 230V rating is site-approveable in Canada on 416V 4-wire Wye distributed systems. The non-inductive rating for 230V "a.c. mains" with one ungrounded conductor is 6.0A.

# ORDERING INFORMATION

Before ordering please determine the following:

1. The body type: 2-way or 3-way
2. The actuator voltage : 24V/50-60Hz
3. The pipe fitting, size, and flow capacity rating (Cv) required.
4. Order Specification Number
5. Accessories, if desired.

If you have additional questions, need further information, or would like to comment on our products or services, please write or phone:

1. Your local Home and Building Control Sales Office (please check the white pages of your phone directory).
2. Honeywell Limited, 155 Gordon Baker Rd., North York, ON M2H 3N7.

In U.S.A. - Honeywell Inc., 1885 Douglas Drive North, Minneapolis, Minnesota 55422-4386 (612) 951-1000. International Sales and Service Offices in all principal cities of the world. Manufacturing in Australia, Canada, Finland, France, Germany, Japan, Mexico, Netherlands, Spain, Taiwan, United Kingdom, U.S.A.

### Operating range:

32 to + 104 F [0 to +40 C], 5 to 95% RH, non-condensing.

### Performance Specifications:

Precision: ±1°F temperature swing [0.9°C differential].

Accuracy: 2°F [1°C] droop with 4 A load.

### Dimensions:

See Fig. 1 - Nominal Dimensions.

### Mounting:

Direct mounting on single-gang NEMA 2" x 3" flush-mount or 2" x 4" surface-mount electrical box, or on 4" x 4" box Models available for vertical or horizontal mount.

### Wiring Connections:

Screw terminal block suitable for 1 – 14 AWG, 2 – 18 AWG, or 1 – 1.5 mm<sup>2</sup> copper wire.

### Approvals:

CSA Certified LR1322

Underwriters Laboratories Listed E47434.

### Accessories:

272824A-T6380 Range stop/cover locking kit.

272827A-T6380 replacement cover with Cool-Warmer

Fig. 1 — Nominal dimensions in inches and millimetres

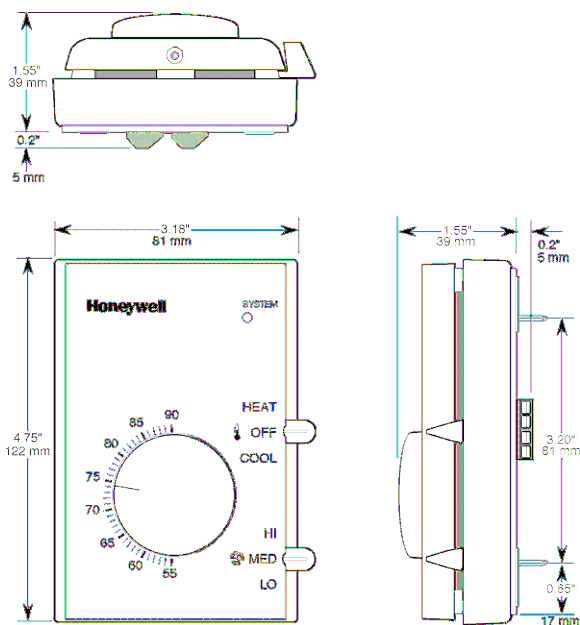

# INSTALLATION

## MOUNTING:

Mount the thermostat on an inside wall 4' to 5' [1.5 m] above the floor. Do not mount where thermostat can be affected by drafts, radiant heat from the sun, or other sources of heat. T6380's mount on NEMA standard 2"x3" single gang flush or 2"x4" surface mount electrical box, or on 4"x4" box with mud ring adaptor (not provided).

## WIRING

3 Internal schematic and external wiring connections are shown in Fig. 2a through Fig. 8c. Wiring connections may be made to the 8 position screw terminal block with 1- 14 AWG, or 2- 18 AWG, solid or stranded copper wires.

Fig. 2a – T6383A for 2-pipe, constant fan, cooling only

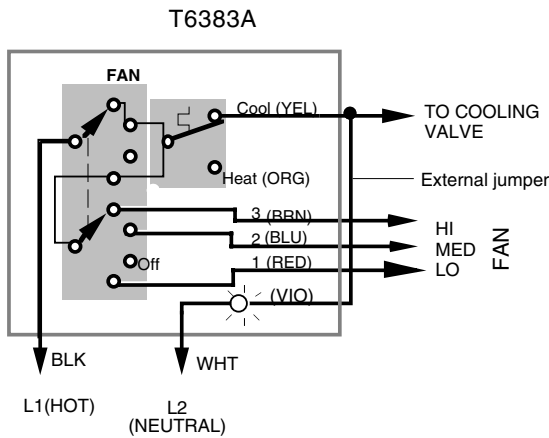

Fig. 2b – T6383A for 2-pipe, constant fan, heating only

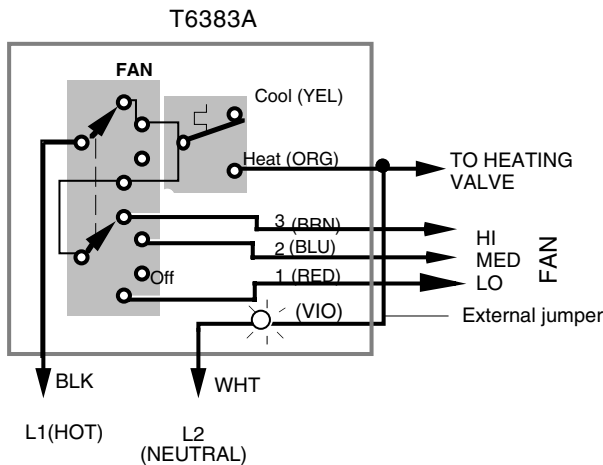

Fig. 2c – T6383A: 2-pipe, heat/cool, seasonal auto-changeover, constant fan

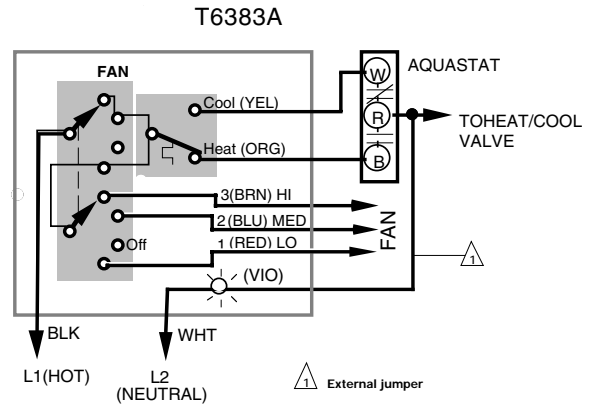

Fig. 3 – T6383B: 2-pipe, heat/cool, manual changeover, constant fan

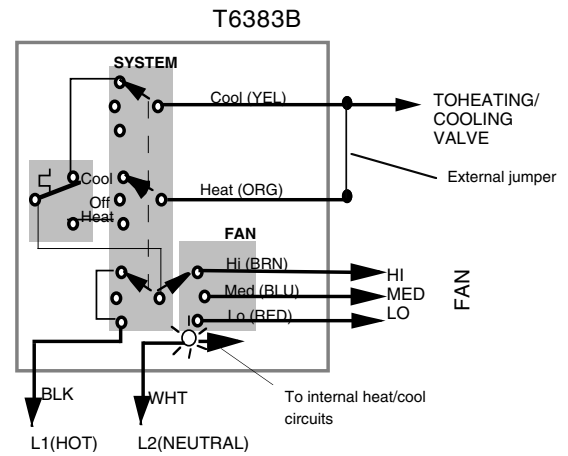
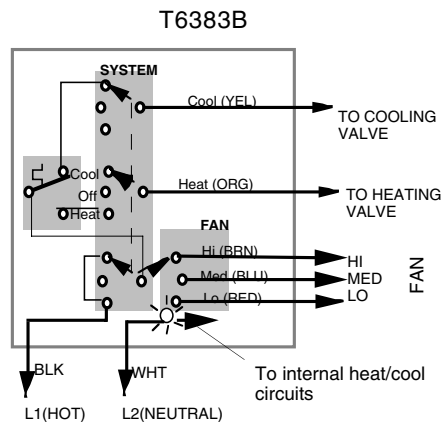
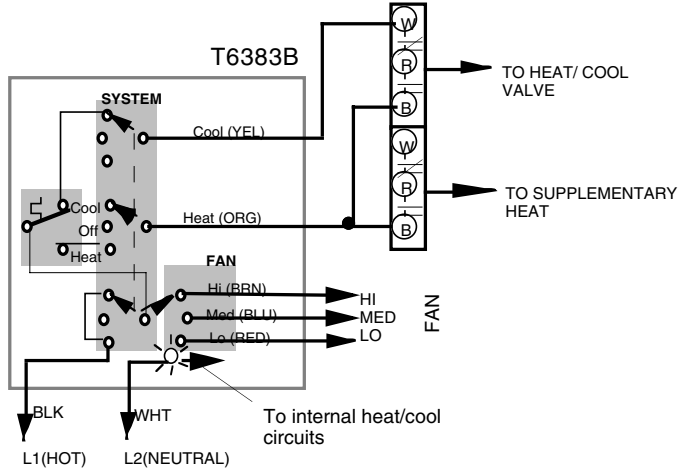

Fig. 4a – T6383B: 4-pipe, heat/cool, manual changeover, constant fan



**Fig. 4b – T6383B: 2-pipe, heat/cool, auto changeover, with aux. electric heat, constant fan**



**Fig. 5c – T6381A: 2-pipe, heat/cool, auto-changeover, cycled fan**

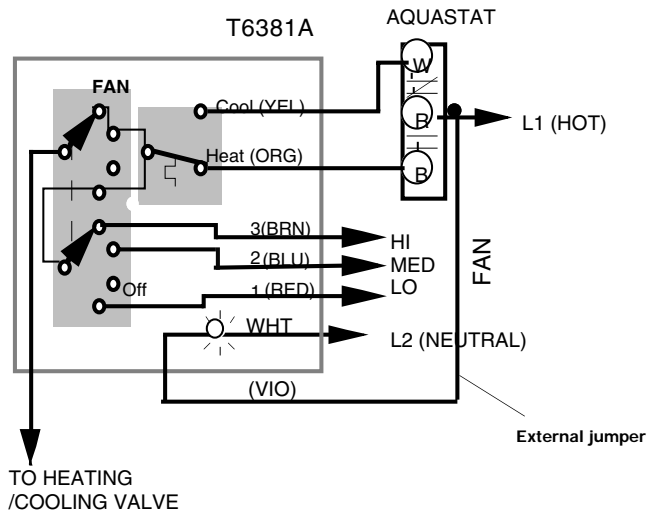

**Fig. 5a – T6381A: 2-pipe, cooling only, cycled fan**

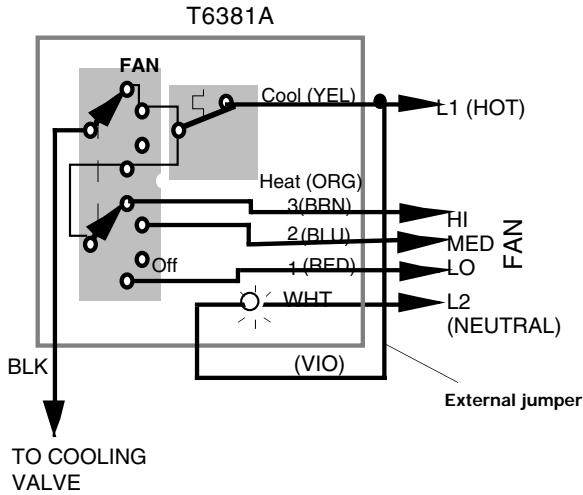

**Fig. 6 – T6381B: 2-pipe, heat/cool, manual changeover, cycled fan**

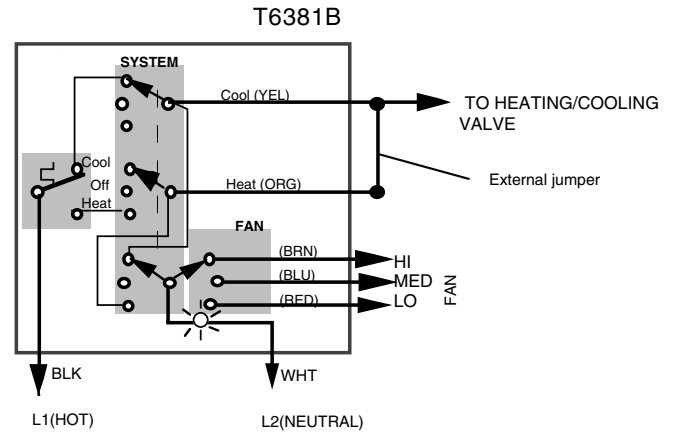

**Fig. 5b – T6381A: 2-pipe, heating only, cycled fan**

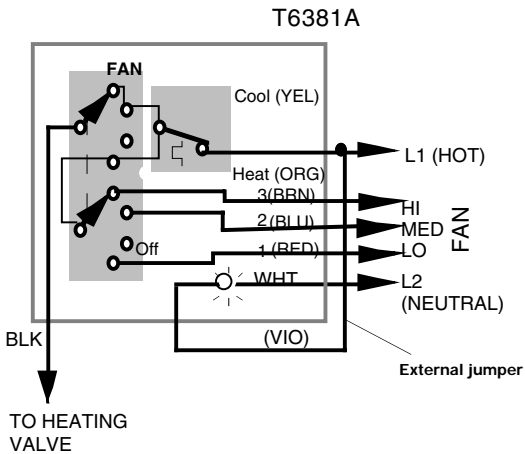

**Fig. 7a – T6381B: 4-pipe, heat/cool, manual changeover, cycled fan**

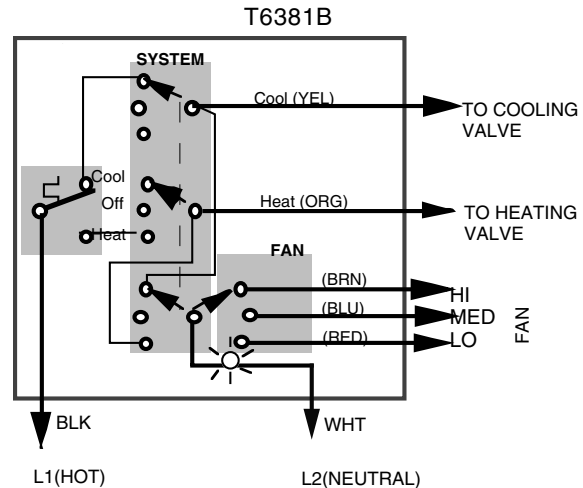

**Fig. 7b – T6381B: 2-pipe, heat/cool, auto-changeover, cycled fan with aux. heat**

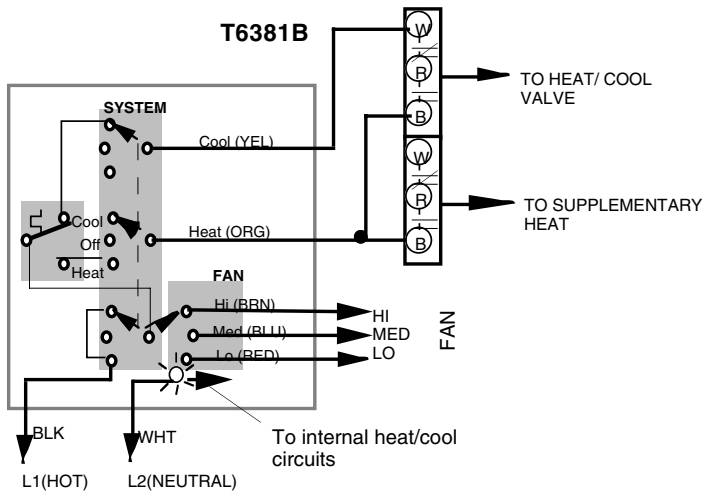

**Fig. 8a – T6387A: 2-pipe, cooling only on–auto fan**

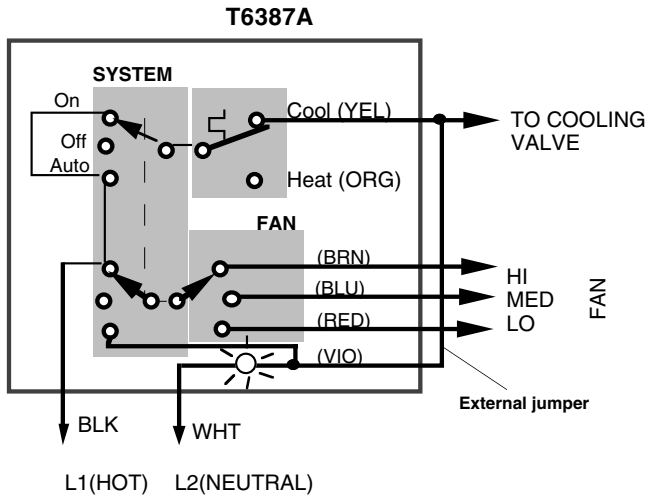

**Fig. 8b – T6387A: 2-pipe, heating only on–auto fan**

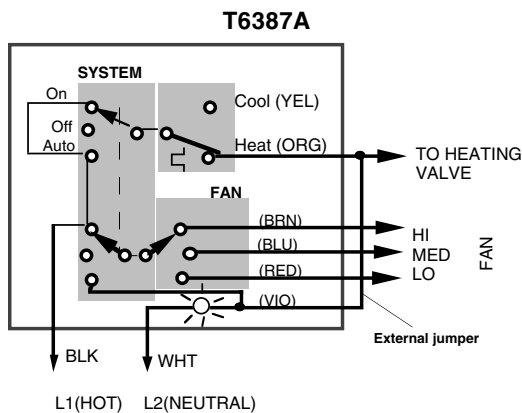

**Fig. 8c – T6387A: 2-pipe, heat/cool, auto-changeover, on–auto fan**

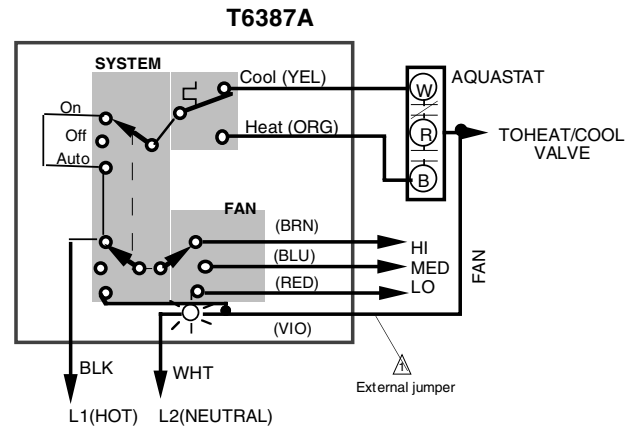

**CAUTION**

1. Disconnect power supply before connecting wiring to prevent electrical shock and equipment damage.
2. Never jumper the supply wires or actuator terminals even temporarily. This may damage the thermostat.

**OPERATION**

As the temperature changes, the thermostat makes to open a valve and/or power a blower to provide heating or cooling. The speed at which the air is circulated is controlled by the FAN switch. Continuous (ON) or intermittent (AUTO) fan operation is determined by model number.

**CHECK-OUT**

Turn power on. Check out operation according to the SYSTEM switch present.

- SYSTEM switch OFF de-energizes valve and fan circuits.

Models T6381B,; T6383B

- SYSTEM: HEAT - OFF - COOL  
Set the SYSTEM switch to HEAT. Rotate the thermostat knob clockwise to energize the heating valve and/or fan (fan auto/cycled mode). The system LED on the thermostat will light when the heating circuit is energized.

Set the SYSTEM switch to COOL. Rotate the thermostat knob counter-clockwise to energize the cooling valve and/or fan (fan auto/cycled mode). The system LED on the thermostat will light.

Model T6387A

- SYSTEM: ON -AUTO - OFF  
Set the SYSTEM switch to ON. The valve will operate on heating or cooling cycle depending on whether hot or chilled water is being supplied. The fan will run continuously.  
Set the SYSTEM to AUTO. The fan will cycle with the heating or cooling operation.

Models: T6381A; T6383A

- SYSTEM: HI-OFF-MED-LO
- Set the SYSTEM switch to HI. Rotate the thermostat knob clockwise to energize the heating\cooling valve and/or fan ( constant or cycled fan). The system LED on the thermostat will light when the heating or cooling circuit is energized.

**SETTING:**

The T6380 temperature scale is marked 55 to 90°F or 13 to 32°C, depending on the model. Set the dial indicator marker to the desired temperature.

**CALIBRATION:**

T6380 thermostats are accurately calibrated at the factory under controlled conditions. Do not attempt to field calibrate this device. This thermostat has line voltage connections.

---

**Honeywell**

**Home and Building Control**  
Honeywell Ltd.  
155 Gordon Baker Road  
North York, Ontario M2H 3N7

In U.S.A.  
Honeywell Inc.  
1985 Douglas Drive North  
Golden Valley, MN 55422-3992

*Helping You Control Your World*