

VC6800, VC6900 Series Floating Control Valves

PRODUCT DATA



FEATURES

- All actuators are interchangeable and suitable for all valves, 1/2" through 1", providing maximum installation flexibility with minimum stocking requirements.
- A locking tab secures the actuator to the body of the valve.
- Multi-directional actuator mount allows for 4 different wiring orientations, thus providing ease of wiring and service.
- Actuator is constructed of moisture and humidity-resistant materials.
- Long service life because the actuator motor de-energises when not in motion.
- Manual opener and position indicator. This "manual opener" position may be used for filling, venting, and draining the system.
- Bayonet-mount for actuator head. Actuator can be installed after plumbing work has been completed, which makes for more efficient on-site installation.
- Body dimensions are comparable to existing Honeywell products (V4043/4044 and V8043/8044), and in most cases can be interchanged.
- Sweat-fitted valves are supplied with the cartridge loose, to facilitate soldering operations (an installation tool is included).
- In this balanced valve design, the internal piston moves up and down, across the water flow. The actuator provides sinusoidal piston travel action for "soft" shut-off and open, to eliminate water hammer in most applications.
- In 2-way valves, flow is bi-directional.
- In 3-way valves, flow can be mixing or diverting.

GENERAL

The VC6800/VC6900 Series Modulating Control Valves provide optimum control of hot and/or chilled water flow in various heating and cooling applications, such as fan coil units, reheat coils and perimeter heating systems.

The VC hydronic valve consists of a valve body and replaceable characterized cartridge assembly. When used with a Honeywell VC6800/VC6900 series actuator, the valve provides linear flow in either diverting or mixing applications. They are designed to provide sinusoidal valve actuator travel, and therefore operate silently and resist water hammer.

Compatible with 24 Vac, 3-wire signal, the VC series valve actuator is used with either a single pole double throw two-position controller for on-off control, or a floating controller, for modulating control. These actuators have conformal coated printed circuit boards for humidity resistance. Through an internal switching mechanism, the actuator takes power only while driving the valve to the commanded position.

Contents

Specifications	2
Ordering Information	2
Installation	4
Wiring	5
Operations	5
Service	5
Check-out	5

SPECIFICATIONS

Table 1. Actuator Model Identifiers

Model Series	Voltage (50/60Hz)	Auxiliary Switch	Nominal full open Time @ 60 Hz	Type of Electrical Connection
VC6830	24 Vac	SPDT	120 sec.	Molex
VC6831	24 Vac	SPDT	120 sec.	1 metre cable
VC6930	24 Vac	-	120 sec.	Molex
VC6931	24 Vac	-	120 sec.	1 metre cable
VC6940	24 Vac	-	12 sec.	Molex

** Plenum rated cover & cable

Table 2. Body Fitting Model Identifiers

2-way Valve Number	Cv Rating	Body Fitting	3-way Valve Number	Cv Rating
AA11xx	3.2	1/2" Sweat	MA61xx	3.8
AC11xx	2.1	3/8" Flare	MB61xx	2.7
AD11xx	3.1	1/2" Flare	MC61xx	3.8
AE11xx	3.2	1/2" Inv. Flare	MD61xx	4.2
AF11xx	3.0	1/2" BSPP/15mm int	ME61xx	3.7
AB11xx	3.4	1/2" BSPT int	MN61xx	3.8
AM11xx	4.6	3/4" Sweat	ML61xx	5.9
AH11xx	5.2	3/4" BSPP ext	MG61xx	6.7
AJ11xx	5.2	3/4" BSPP int	MH61xx	6.9
AK11xx	4.7	3/4" BSPT int	MJ61xx	6.2
AL11xx	4.7	3/4" NPT int	MK61xx	6.6
AG11xx	5.4	22mm Compression*	MF61xx	6.9
AP11xx	6.6	1" BSPP int	MP61xx	7.5
AQ11xx	6.2	1" BSPP ext	MQ61xx	7.9
AS11xx	6.2	1" Sweat	MS61xx	6.6
AR11xx	6.6	1" NPT int	MR61xx	8.6
AT11xx	6.6	1" BSPT int	MT61xx	8.1
AN11xx	6.3	28mm Compression*	MM61xx	7.5

*Includes compression nuts and olives

For example, to order a 120 second stroke timing actuator, with 1 meter cable and no auxiliary switch, on a 3-way 3/4" BSPP internal thread body, you would order VC6931MH6111. The last two digits, "11", indicate that the actuator comes with conformal coated printed circuit board.

ORDERING INFORMATION

Before ordering please determine the following:

1. The body type: 2-way or 3-way
2. The actuator voltage : 24V/50-60Hz
3. The pipe fitting, size, and flow capacity rating (Cv) required.
4. Order Specification Number
5. Accessories, if desired.

If you have additional questions, need further information, or would like to comment on our products or services, please write or phone:

1. Your local Home and Building Control Sales Office (please check the white pages of your phone directory).
2. Honeywell Limited/Honeywell Limitée, 35 Dynamic Drive, Scarborough, ON M1V 4Z9.

In U.S.A. - Honeywell, 1885 Douglas Drive North, Minneapolis, Minnesota 55422-4386. International Sales and Service Offices in all principal cities of the world. Manufacturing in Australia, Canada, Finland, France, Germany, Japan, Mexico, Netherlands, Spain, Taiwan, United Kingdom, U.S.A.

Voltage:
24V, 50-60Hz Model

Colour coded label
Blue

Power Consumption:

4 Watts Max. at nominal voltage (during valve position change).

Note: Use 6 VA for Class 2 transformer and connection wire sizing. Maximum duty cycle 15%.

End Switch Rating:

2.2 A inductive from 5 to 110 Vac

1.0 A inductive above 110 to 277 Vac

Min. DC switching capability: 0.005 A @ 24 Vdc

Note: Use model V6831 only for mixed line and low voltage applications.

Nominal Timing:

See Table 1

Note: Timing is approximately 20% longer @ 50Hz

Electrical Termination: 3 Versions Available:

1) Molex™ (header #39-30-1060). Requires mating connector (receptacle/housing #39-01-2060), or

2) With integral 1 metre (nominal 39") leadwire cable, or

Operating Ambient Temperature:

0 to 65 degrees C (32 to 150 degrees F)

Shipping and Storage Temperature:

-40 to +65 degrees C (-40 to 150 degrees F)

Atmosphere:

Non-corrosive, non-explosive

Minimum & Maximum fluid temperatures:

1 to 95 degrees C (34 to 203 degrees F)

Operating Pressure Differential:

Maximum - 4 bar (60 psi)

Pressure Rating: Static - 20 Bar (300 psi)

Burst - 100 Bar (1500 psi)

Valve Material:

Body of bronze

Cartridge of Ryton™ (polyphenylene sulphide) and Noryl™ (polyphenylene oxide);

O-ring seals of EPDM rubber;

Stem of stainless steel.

Stem Travel: 10 mm (0.4 inches)

Flow Characteristics: Linear

The specifications above are nominal and conform to generally acceptable industry standards. Honeywell is not responsible for damages resulting from misapplication or misuse of its products.

Approvals:

Underwriters Laboratories Inc. Listed
 CSA Approved
 CE Approved under EMC 89/336/EEC

Accessories and Replacement Parts:

40007029-002: Wrench for removing VC cartridge
 VCZZ1100: 2-way characterized cartridge, unit pack
 VCZZ6100: 3-way characterized cartridge, unit pack

Fig. 1 - Nominal dimensions in inches and millimetres

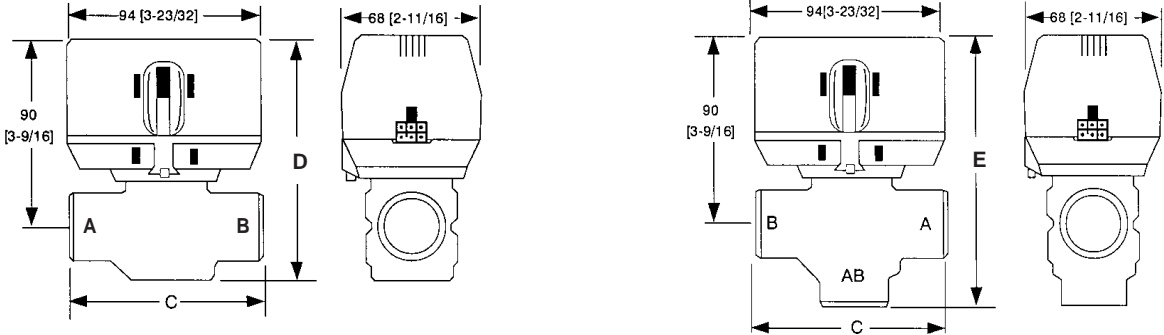

Table 3. 2-Way Nominal Dimensions

Pipe fitting sizes	Dimensions	C		D	
		mm	Inches	mm	Inches
3/8" FLARE (no adapter)		98	3 -7/8	111	4-3/8
1/2" SWEAT		98	3 -7/8	111	4-3/8
1/2" FLARE (no adapter)		98	3 -7/8	111	4-3/8
1/2" INVERTED FLARE (no adapter)		98	3 -7/8	111	4-3/8
1/2" BSPP(int.), 15 mm COMP.		98	3 -7/8	111	4-3/8
1/2" BSPP(int.)		98	3 -7/8	111	4-3/8
3/4" BSPP (int. & ext.), 3/4" BSPT (int.)		94	3-11/16	113	4-7/16
3/4" NPT (int.)		94	3-11/16	113	4-7/16
3/4" SWEAT		94	3-11/16	113	4-7/16
22mm* COMPRESSION		112	4-7/16	113	4-7/16
1" BSPP (int. & ext.), 1" NPT (int.)		94	3-11/16	113	4-7/16
1" SWEAT		94	3-11/16	113	4-7/16
28mm* COMPRESSION		116	4-9/16	113	4-7/16

Table 4. 3-Way Nominal Dimensions

Pipe fitting sizes	Dimensions	C		E	
		mm	Inches	mm	Inches
3/8" FLARE (no adapter)		98	3 -7/8	136	5-11/32
1/2" SWEAT		98	3 -7/8	136	5-11/32
1/2" FLARE (no adapter)		98	3 -7/8	136	5-11/32
1/2" INVERTED FLARE (no adapter)		98	3 -7/8	136	5-11/32
1/2" BSPP(int.), 15 mm COMP.		98	3 -7/8	136	5-11/32
1/2" BSPP(int.)		98	3 -7/8	136	5-11/32
3/4" BSPP (int.), 3/4" BSPT (int.)		94	3-11/16	130	5-3/32
3/4" BSPP (ext.)		94	3-11/16	130	5-3/32
3/4" NPT (int.)		94	3-11/16	130	5-3/32
3/4" SWEAT		94	3-11/16	132	5-3/16
22mm* COMPRESSION		112	4-7/16	140	5-1/2
1" BSPP (int. & ext.), 1" NPT (int.)		94	3-11/16	136	5-11/32
1" SWEAT		94	3-11/16	136	5-11/32
28mm* COMPRESSION		116	4-9/16	147	5-13/16

*includes compression nuts and olives

Fig. 2 - Fluid flow of 2-way valves

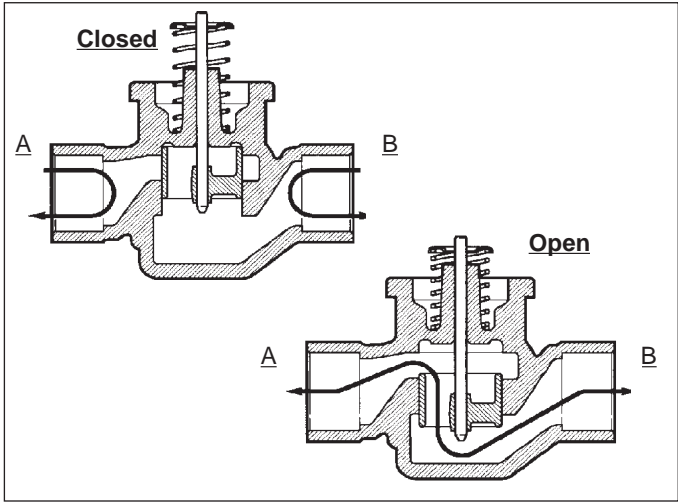
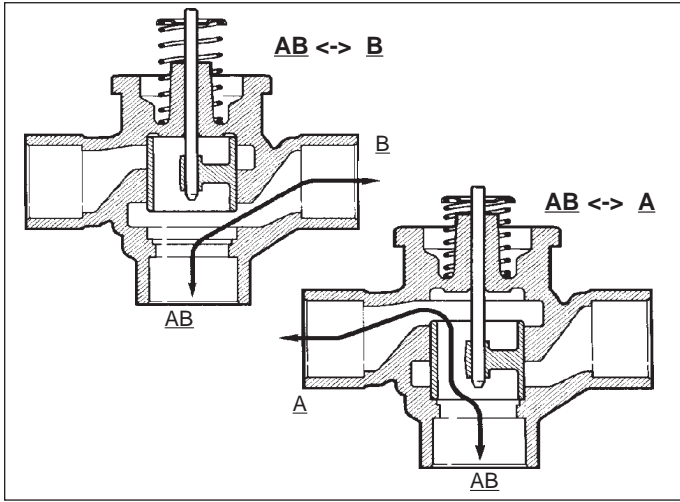

Fig. 3 - Fluid flow of 3-way valves



INSTALLATION

WHEN INSTALLING THIS PRODUCT:

1. Read these instructions carefully. Failure to follow them could damage the product or cause a hazardous condition.
2. Check the ratings given in the instructions and on the product to make sure the product is suitable for your application.
3. Installer must be a trained, experienced service-person.
4. Always conduct a thorough check-out when installation is completed.
5. While not necessary to remove the actuator from the body, it can be removed for ease of installation. The actuator can be installed in any of the four orientations to suit the most convenient wiring direction. Actuator latching mechanism works only when the lengths of the actuator and the valve body are parallel to each other.
6. An extra 25 mm head clearance is required to remove the actuator.



CAUTION

1. Disconnect power supply before connecting wiring to prevent electrical shock and equipment damage.
2. Never jumper the supply wires or actuator terminals even temporarily. This may damage the thermostat.

PLUMBING

The valve may be plumbed in any angle but preferably not with the actuator below horizontal level of the body. Make sure there is enough room around the actuator for servicing or replacement.

For use in diverting applications, the valve is installed with the flow water entering through bottom port AB, and diverting through end ports A or B. In mixing applications the valve is installed with inlet to A or B and outlet through AB.

Mount the valve directly in the tube or pipe. Do not grip the actuator while making and tightening up plumbing connections. Either hold valve body in your hand or attach adjustable spanner (38 mm or 1-1/2") across hexagonal or flat faces on the valve body. (Figure 4)

COMPRESSION MODELS

For compression fitted models, tighten the compression nuts enough to make a watertight seal. **TAKE CARE NOT TO OVER TIGHTEN.** Maximum torque limit is 45Nm (33 ft.-lb.) for the 22 mm compression fitting, and 65Nm (48 ft.-lb) for the 28 mm compression fitting.

Fig. 4 - Plumbing of the VC Valve

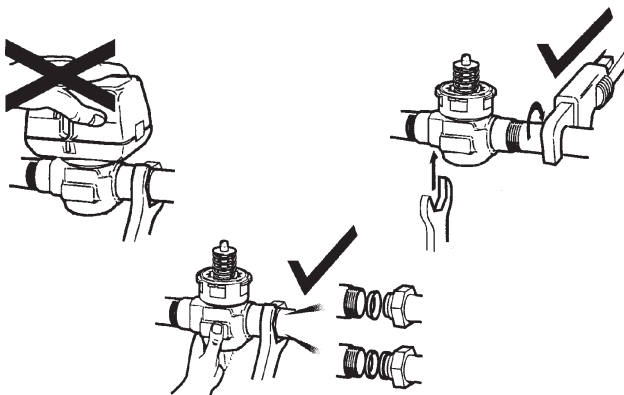

SWEAT MODELS

On sweat fitted valves, the cartridge is shipped loose to avoid being damaged during the solder operation.

1. Remove valve actuator from body and solder the connecting pipes in accordance with normal soldering practices.
2. After soldering and valve has cooled, remove cartridge assembly from plastic bag, insert into the valve body and tighten down with enclosed wrench(part# 40007029-002) until it bottoms out. **DO NOT OVER TIGHTEN** (maximum torque is 4.5Nm [40 in-lb]). The top surface of the cartridge will be flush with the top edge of the body casting.
3. Replace valve actuator.

TO INSTALL REPLACEMENT ACTUATOR

IMPORTANT

Installation of a new actuator does not require draining the system, provided the valve body and valve cartridge assembly remain in the pipeline.

1. Check replacement part number and voltage ratings for match with old device.
2. Disconnect power supply before servicing to avoid electrical shock or equipment damage.
3. Disconnect leadwires to actuator, or depress tab on Molex™ connector and remove. Where appropriate, label wires for rewiring.
4. The actuator head is automatically latched to the valve. To remove, press up on the latch mechanism with your thumb. It is located directly below the white manual open lever (see figure 5 below). Simultaneously press the actuator down towards the body with moderate hand force and turn the actuator counter-clockwise by 1/8 turn (45 degrees). Lift the actuator off the valve body.

NOTE: The actuator can also be installed at right angles to the valve body but in this position the latch mechanism will not engage.

5. Install the new actuator by reversing the process in (4).
6. Reconnect leadwires or Molex™ connector.
7. Restore power, and check-out operation.

Fig. 5 - Latch Mechanism to detach Actuator

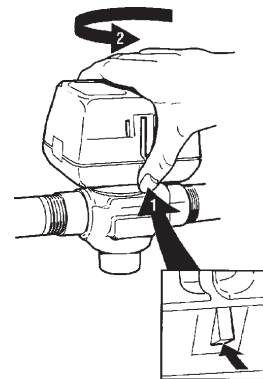

MANUAL OPENER

The manual opener can be manipulated only when in the up position. The "A" port can be manually opened by firmly pushing the white manual lever down to midway and in. In this position both the "A" and "B" ports are open, and with auxiliary switch models the switch is closed. This "manual open" position may be used for filling, venting and draining the system, or for opening the valve in case of power failure. The valve can be restored manually to the closed position by depressing the white manual lever lightly and then pulling the lever out. The valve and actuator will return to the automatic position when power is restored.

NOTE: If the valve is powered open, it cannot be manually closed, unless actuator is removed.

WIRING

One controller and a separate transformer is required to operate each valve. Figures 6a and 6b show wiring connections. Port "A" *open* and *closed* denote valve open and closed positions respectively. On auxiliary switch models, contact makes in between (NC) terminal 1 (orange wire) and (NO) terminal 4 (grey wire) in mid-range of opening cycle. On Molex™ connector models, valve & auxiliary switch voltage must be the same to meet approval requirement. When mixing line voltage and 24 Vac (Safety Extra Low Voltage) application together, the cable version must be used.

Fig. 6a - Connector Pin Configuration for Molex™ Models for SPDT, floating Controller (Series 60).

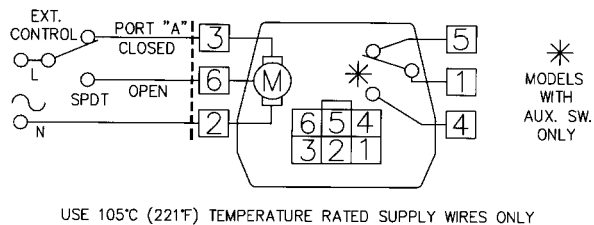

USE 105°C (221°F) TEMPERATURE RATED SUPPLY WIRES ONLY

Fig. 6b - Wiring Colour Code for Cable Models for SPDT, floating Controller (Series 60).

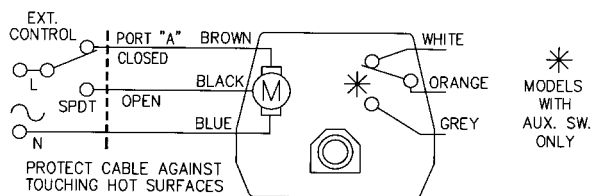

PROTECT CABLE AGAINST TOUCHING HOT SURFACES

OPERATIONS

WITH SERIES 60 FLOATING CONTROLLER:
(refer to figure 7)

The series 60 floating controller is an SPDT controller with a centre-off position. On a change in temperature from the set point,

the controller will close the NO or NC contacts, driving the valve to an intermediate position until a further change at the controller. The valve is set between the limits of the controller to satisfy various load requirements. In the event of a power failure, the valve will stay at whatever position it was in when the power was interrupted. When power is restored, the valve will respond to the controller demand.

Fig. 7 - Wiring Schematic of the VC6900 Series Actuators

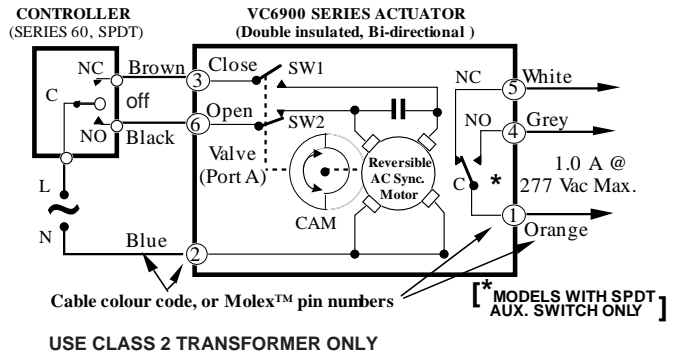

SERVICE

This valve should be serviced by a trained, experienced service technician.

1. If the valve is leaking, drain system **OR** isolate valve from the system. Do not remove valve body from plumbing.
2. Check to see if the cartridge needs to be replaced.
3. If the motor or other internal parts of the actuator is damaged, replace the entire actuator assembly.

NOTE: Honeywell hydronic valves are designed and tested for silent operation in properly designed and installed systems. However, water noises may occur as a result of excessive water velocity. Piping noises may also occur in high temperature (over 212°F [100°C]) systems with insufficient water pressure.

IMPORTANT

Do not use boiler additives which are petroleum based or contain mineral oil, hydrocarbons, or ethylene glycol acetate. Compounds which can be used, with minimum 50% water dilution, are diethylene glycol, ethylene glycol, and propylene glycol (anti-freeze solutions).

CHECK-OUT

1. Raise the set point of the thermostat above room temperature to initiate a call for heat.
2. Observe all control devices - The 2 way valve should open. Port A of the 3 way valve should open, port B should close. The auxiliary switch (if present) should operate and make at the end of the opening stroke, activating the auxiliary equipment.
3. Lower the set point of the thermostat below room temperature.
4. Observe the control devices. The 2 way valve should close. Port A of the 3 way valve should close. All auxiliary equipment should stop.

Honeywell

Home and Building Control
Honeywell Ltd.
155 Gordon Baker Road
North York, ON M2H 3N

In U.S.A.
Honeywell Inc.
1985 Douglas Drive North
Golden Valley, MN 55422-3992