

GENERAL INFORMATION

Proportional pneumatic actuator with 11 sq. in. (71 cm²) effective area used to control damper and air valves in heating, ventilating and air conditioning systems.

OPERATION

The type of positioning, proportional or two-position, is determined by the controller, such as a thermostat or relay. Actuators are positioned by air pressure acting upon a diaphragm and piston. Opposing the force on the top of the piston is a spring. The piston force overcomes the spring force, as the air pressure increases, extending the actuator shaft. If the pressure lessens, the spring force retracts the shaft.

CONSTRUCTION

Units are constructed of a sturdy die cast aluminum housing enclosing an easily replaceable beaded molded neoprene diaphragm, steel piston, piston shaft, sintered bronze shaft-guide bushing and steel spring.

The molded neoprene diaphragm has a circular bead which mates with a groove in the pressure housing insuring positive locating and sealing of the diaphragm with the housing.

STROKE LENGTH

Adjustable 1/2 to 3" (13 to 76 mm). Factory set at 2" (51 mm).

MAXIMUM SAFE AIR PRESSURE

30 psig (207 kPa).

AMBIENT TEMPERATURE LIMITS

-20 to 160°F (-29 to 71°C).

MOUNTING

In any position. Mounting bracket, linkage and connector for 5/16" (8 mm) diameter push rod included.

AIR CONNECTIONS

1/8" FNPT.

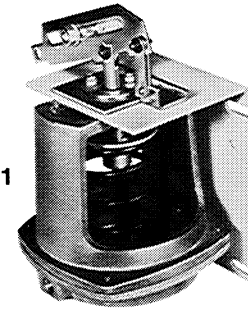

MK-44X1

DIMENSIONS

7-7/16" (189 mm) high × 5-3/4" (146 mm) wide × 4-7/8" (124 mm) deep.

OPTIONS

None.

ACCESSORIES

| | |
|------------|---|
| AM-111 | Crank arm for 5/16" diameter damper shaft |
| AM-112 | Crank arm for 3/8" diameter damper shaft |
| AM-113 | Crank arm for 1/2" diameter damper shaft |
| AM-115 | Crank arm for 7/16" diameter damper shaft |
| AM-122 | Linkage connector straight type |
| AM-123 | Damper clip |
| AM-125 | 5/16" × 20" damper rod |
| AM-125-048 | 5/16" × 48" damper rod |
| AM-132 | Ball joint connector |
| AM-161-3 | Damper linkage kit |
| Tool-95 | Pneumatic calibration tool kit |

| Damper Type | Nominal Damper Area for Proportional* Control** | Nominal Damper Area for Two-Position Control MK-4421 (8-13 Spring, 20 psi Supply)** |
|----------------|---|---|
| Parallel Blade | 4.4 sq. ft. | 13.2 sq. ft. |
| Opposed Blade | 5.6 sq. ft. | 16.8 sq. ft. |

*MK-4421 requires 15 psi be available to actuator, MK-4461 requires 20 psi be available to actuator.

**Damper ratings are nominal and based on standard (not low leakage) damper at 1" W.C. static pressure and 2000 fpm (10 m/s) velocity.

| Part Number | Nominal Operating Range | Starting Pressure Adjustable | Maximum Force†† | | | | Nominal Torque** Proportional Control†† | | |
|-------------|-------------------------|------------------------------|---------------------------------------|----------------------------------|-------------------------------------|---|---|-------------------------------------|---|
| | | | Return Stroke | Power Stroke | | | 15 psi Supply Dual Press. System | 15 psi Supply Single Press. System† | 20 psi Supply Single or Dual Press. System† |
| | | | Based on 1.5 psi Pressure to Actuator | 15 psi Supply Dual Press. System | 15 psi Supply Single Press. System† | 20 psi Supply Single or Dual Press. System† | | | |
| psi | psi | lb. | lb. | lb. | lb. | lb-in. | lb-in. | lb-in. | |
| MK-4401 | 3-8 | 3 ± 1 | 8.25 | 30.25 | 38.5 | 66 | 7.9 | 7.9 | 7.9 |
| MK-4411 | 5-10 | 5 ± 1 | 19.25 | 19.25 | 27.5 | 55 | 7.9 | 7.9 | 7.9 |
| MK-4421 | 8-13 | 8 ± 1 | 35.75 | 2.75 | 11 | 38.5 | 2.6 | 7.9 | 7.9 |
| MK-4451 | 3-6,9-12 | 3 to 6 | 8.25 | 8.25 | 16.5 | 44 | 7.9 | 7.9 | 7.9 |
| MK-4461 | 3-6,11-17 | 3 to 6 | 8.25 | 0 | 0 | 16.5 | 0 | 0 | 7.9 |

**Nominal torque for actuators is based on 1.5 psi pressure change at the actuator.

††Force and torques based on factory set stroke and starting pressure.

†Adjust pressure reducing valve so that listed pressures are available at the actuator.

Relationship between Stroke and Control Air Pressure for Two-Stage Actuators

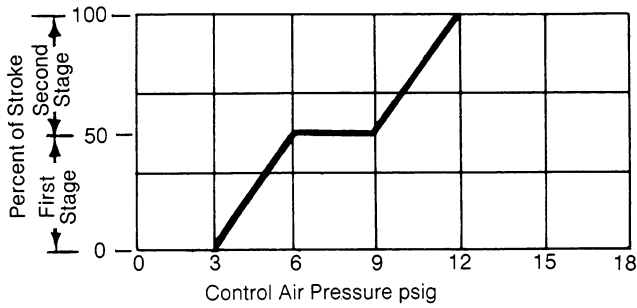

Figure 1. MK-4451

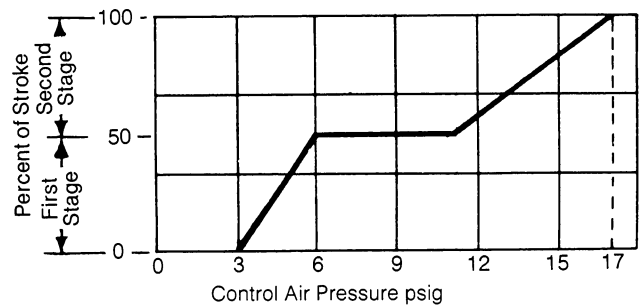

Figure 2. MK-4461

INSTALLATION

Make all connections in accordance with job piping diagram. Use 1/4" OD copper or plastic tubing to connect the actuator to the controller. Units have 1/8" NPT female inlet for connection to the supply air. Actuators are mounted by means of four screws (not included) through the mounting bracket. See Figure 3 for mounting dimensions.

Insert the push rod in the actuator and damper connectors and tighten the set screws. (See Figure 4 for damper linkage for 90° rotation.) Apply air pressure and run the actuator through the entire stroke. Readjust linkage if binding occurs during damper shaft rotation. Readjustment may also be necessary if damper shaft does not achieve acceptable rotation.

ADJUSTABLE STARTING PRESSURE

The start point is the air pressure value that causes the actuator shaft to just begin to extend. If adjustment of starting pressure is required, turn adjusting nut supporting the spring clockwise to decrease and counterclockwise to increase the starting pressure, when viewing the actuator from the shaft end (Figure 3). Each rotation of the adjusting nut changes the starting pressure 0.04 psi (.28 kPa).

NOTE

The stroke during the first stage of operation (MK-4451 & MK-4461) is adjustable from 0 to 50% of total stroke.

DIAPHRAGM REPLACEMENT

If the actuator diaphragm should leak, it may easily be replaced:

1. Disconnect air line to the actuator.
2. Remove the screws on the top power housing, the top cover and the old diaphragm.
3. Insert new diaphragm over piston.

IMPORTANT

Put the top power housing back in place making sure the bead on the diaphragm is in the housing groove and the screw holes are lined up.

4. Tighten the top power housing screws.

MAINTENANCE

This is a quality product. Regular maintenance of the total system is recommended to assure sustained optimum performance.

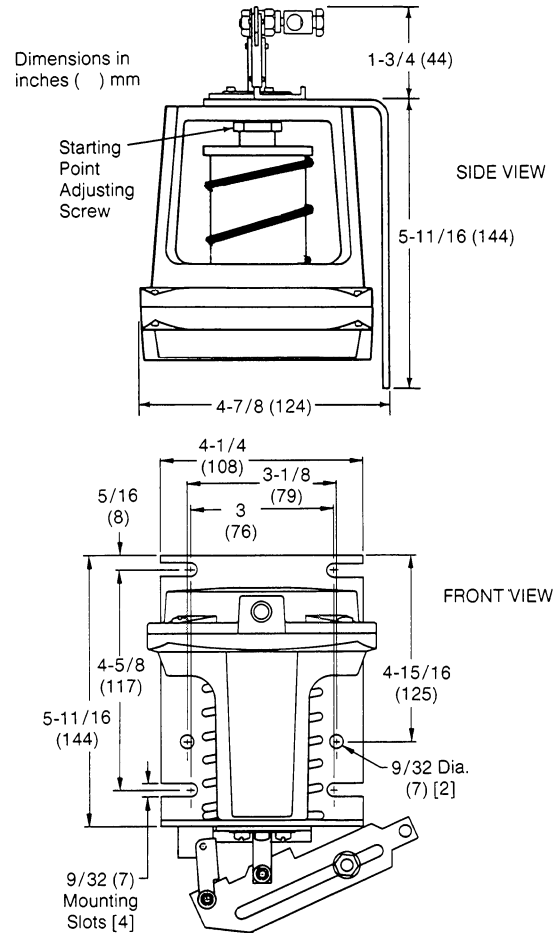

Figure 3.

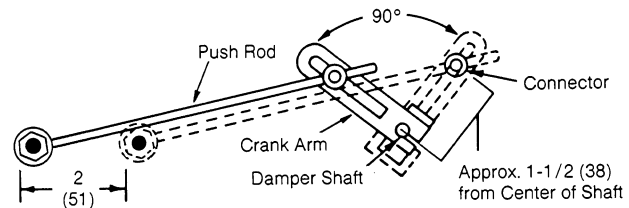

Figure 4.