

Proportional actuators for control of inlet vanes on small or medium fans or large jackshafted dampers. Unit is spring returned. Diaphragm is a tough, wear-resistant, molded, neoprene rubber. Positive positioner supplied as standard.

No Load Operating Range: 55–90 kPa (8–13 psig)

Maximum Safe Air Pressure: 207 kPa (30 psig)

Ambient Temperature Limits: –29°C (–20°F) minimum, 71°C (160°F) maximum.

Air Connections: Barbed brass fittings for 1/4-inch O.D. plastic tubing (no clamps required).

Connector can be positioned from 101 to 330 mm [4 to 13"] radius from centerline of jackshaft in increments of 25 mm [1"].

Output of stroke is equal to connector radius.

Table 1

Actuator Part Number	Operating Range (psi)		Starting Pressure (psi)		Max Torque with 138 kPa (20 psig) Supply				Nominal* Torque for Proportional Control	Diaph. Area
					Power Stroke	Return Stroke	Power Stroke	Return Stroke		
					Lb.-In.		N-m			
MK-7821 Single	55–90	8–13	55	8	315	360	35.5	40.6	7.6 N-m (67.5 lb.-in.)	129 sq. cm. (20 sq. in.)
MK-7921 Dual	55–90	8–13	55	8	630	720	71.0	81.2	15.2 N-m (135 lb.-in.)	

*Based on a 10 kPa (1.5 PSIG) pressure change at the Actuator.

Table 2

Damper Rating		
Damper Type	Proportional or Two Position Control	
	MK-7821	MK-7921
Parallel Blade	10.5 sq. m (112.5 sq. ft.)	20.9 sq. m (225 sq. ft.)
Opposed Blade	13.9 sq. m (150 sq. ft.)	27.8 sq. m (300 sq. ft.)

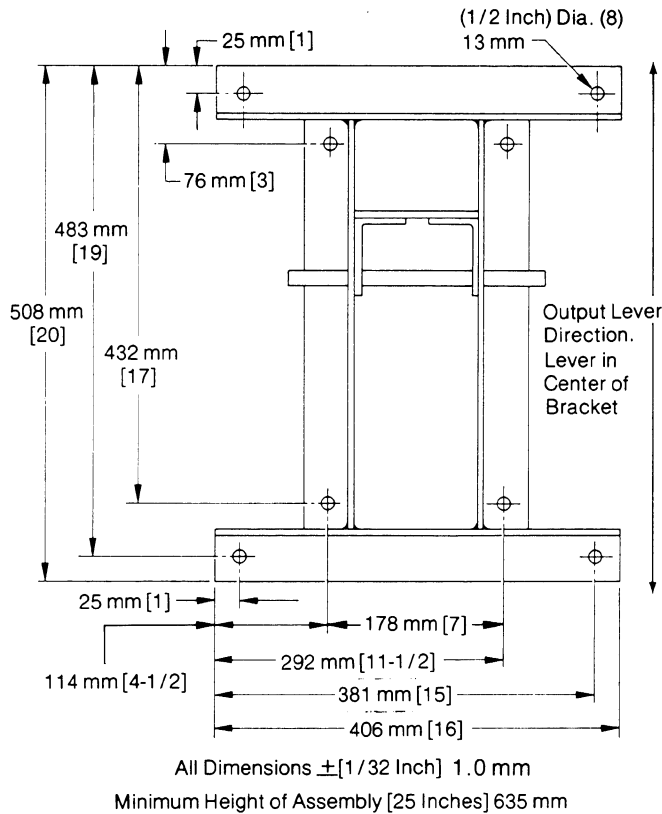

Figure 1. Floor Mounting Bracket Bolt Hole Dimensions

INSTALLATION

I. Mounting and Linkage of Actuators

To facilitate shipping and storage, these actuators are shipped bolted to a wooden pallet. Remove pallet before installation. The actuator mounting bracket is provided with (8) 13 mm ($\frac{1}{2}$ " dia. mounting holes dimensioned as shown in Fig. 1. Before securing mounting bracket to the floor, determine the most efficient actuator location as follows:

- A. From data supplied by damper or fan manufacturers find:
 1. Torque; or force at driven lever length (R).
 2. Angular rotation; or stroke at lever length (R).
- B. From Table 3 or 3A, find the unknown variable of:
 1. Length of lever (L) Fig. 2, or
 2. Length of lever (R) Fig. 2, or
 3. Angular rotation of driven lever (R).
 4. Force delivered by actuator.

Example: Given angular rotation of lever (R) = 37° torque of 46.5 N-m (412 lb. inches) and actuator MK-7821, find:

- a. Length of driven lever (R).
- b. Force required on lever (R).
- c. Length of lever (L).
- d. Is actuator sized right?

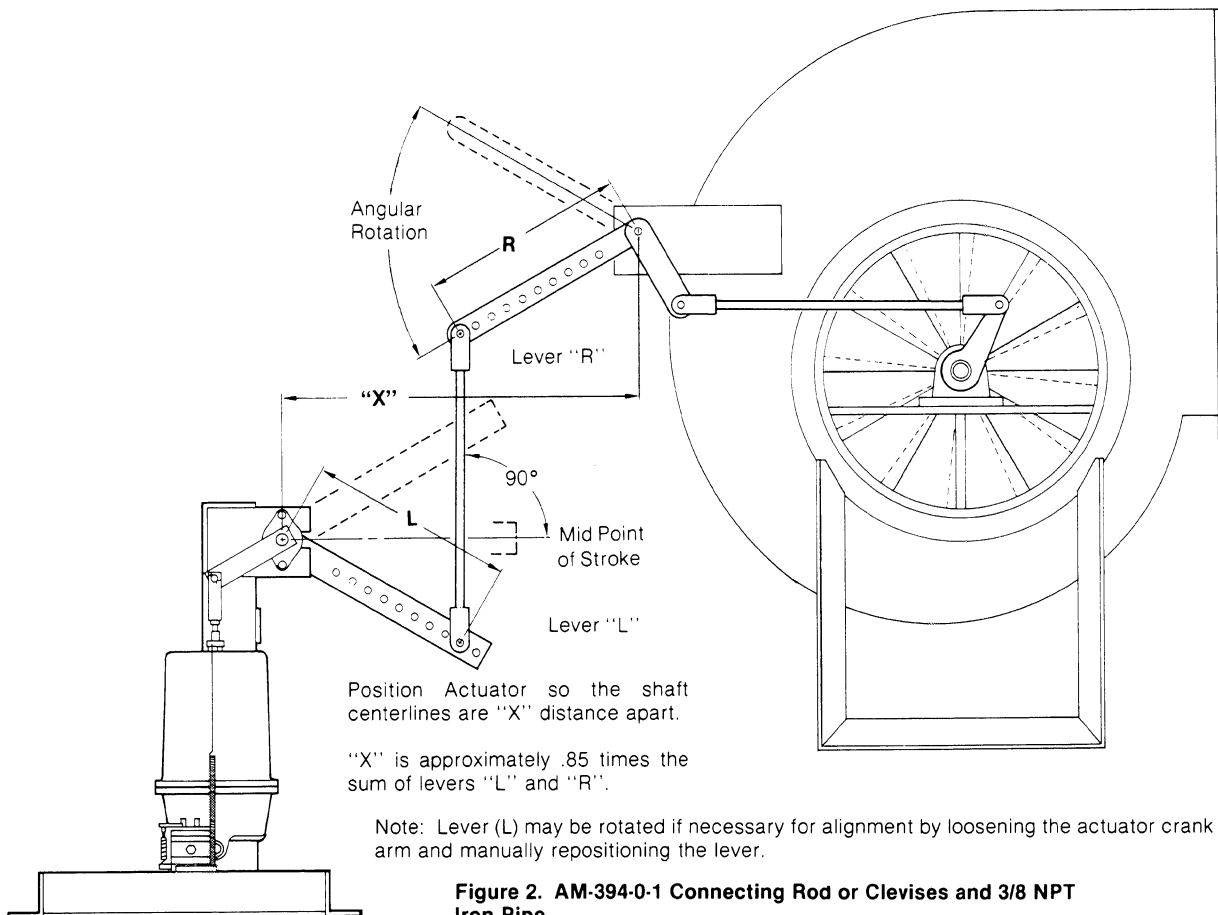

Figure 2. AM-394-0-1 Connecting Rod or Clevises and 3/8 NPT Iron Pipe.

Step 1. Select any reasonable length of lever (R). In this example use 279 mm (eleven inches).

Step 2. Determine the force required: Dividing the torque of 46.5 N-m (412 lb-in.) by .279 m (eleven inches) equals a required force of 166 N (38 lbs.).

Step 3. Determine the length of lever (L). Find the length of lever (R) 279 mm (eleven inches) at the left hand column of Table 3, read across to find 37° angular rotation, then read up to find 178 mm (7 inches) for lever (L).

Step 4. Determine if actuator is sized correctly:

Find force delivered by actuator, MK-7821, 342 N (77 lbs.) at bottom of 178 mm (seven inch) lever (L) column Table 3. This force must be equal to, or greater than, the force required 166 N (38 lbs.). Since this condition is met in this example, the actuator is correctly sized.

C. Prepare damper or fan, etc.

Included with each actuator is an AM-394-0-1 connecting link, adjustable from 400 mm (15-3/4") to 628 mm (24-3/4"). Also two clevises are included which will accept 3/8" NPT iron pipe as a connecting rod.

Mount AM-394-0-1 connecting rod, or clevis and iron pipe to lever (R) Fig. II. (Mount per lever (R) dimension determined under A above. Drill mounting hole in lever (R) if necessary.) Loosely connect lever (L) to clevis and pipe, or AM-394-0-1 connecting rod.

D. Position actuator and secure actuator to floor:

The most efficient actuator mounting position is when lever (R) and lever (L) are aligned in the same plane so no side loading is introduced on either lever. Also the connecting rod should form a 90° angle with a line drawn from actuator jackshaft center-line to mid-point of arc of lever (L), when actuator is at either end of its stroke. (See Fig. II.) Bolt actuator to the floor using at least four of the eight mounting holes provided for this purpose. Mounting bolts are not furnished. Make final linkage adjustments and tighten linkage.

CAUTION: On fan installations employing vibration isolators, actuator must be mounted on the base common to the fan.

II. Connection of Air Lines

- A. Connect main air to port 3 of positive positioner, terminating with at least 152 mm (6 inches) of plastic tubing to allow actuator to pivot.
- B. Connect a variable air supply to port 2 and set pressure at desired start point. Note pressure.
- C. Slide range slider to desired range of pressure change required to produce full actuator stroke.
- D. Adjust start point screw until actuator shaft just starts to move.
- E. Gradually, raise signal to port 2 until actuator is fully extended. Note pressure. If not correct, readjust range slider in proper direction and repeat steps 2 thru 5.
- F. Disconnect variable air supply from port 2 and connect controller output, terminating with at least 152 mm (6 inches) of plastic tubing.

NOTE: Do not use petroleum base pipe dope on positive positioner. Use Teflon tape or pipe-tite stick.

III. Speed Adjustment

To balance the system it may be desirable to change the response time, or speed, of the actuator. These units are equipped with a speed adjustment needle valve in the air line between the positive positioner and the actuator. To reduce speed of actuator, turn valve thumb screw handle clockwise. When desired speed is obtained, tighten lock nut on valve stem to secure setting.

IV. Diaphragm Replacement

If the actuator diaphragm should leak, it may easily be replaced by removing the four screws holding the top power housing. Make sure swivel joint or clevis is in place on the end of the shaft. Remove the screws and old diaphragm. Insert new diaphragm over piston. Replace top power housing, making sure bead on diaphragm is in place in the groove and screw holes are lined up. Tighten housing screws.

Table 3

(Use shaded area to follow example in installation instructions.)

		Length of Driving Lever (L) inches										
		4"	5"	6"	7"	8"	9"	10"	11"	12"	13"	
Length of Driven Lever (R) inches	4"	60°	77°	97°	122°	180°						
	5"	47°	60°	74°	89°	106°	128°	180°				
	6"	39°	49°	60°	71°	84°	97°	113°	133°	180°		
	7"	33°	42°	51°	60°	70°	80°	91°	104°	118°		
	8"	29°	37°	44°	52°	60°	69°	77°	87°	97°	108°	
	9"	26°	32°	39°	46°	53°	60°	68°	75°	84°	93°	
	10"	23°	29°	35°	41°	47°	54°	60°	67°	74°	81°	
	11"	21°	26°	31°	37°	43°	48°	54°	60°	66°	73°	
	12"	19°	24°	29°	34°	39°	44°	49°	54°	60°	66°	
	13"	18°	22°	27°	31°	36°	41°	45°	50°	55°	60°	
	14"	16°	21°	25°	29°	33°	38°	42°	46°	51°	55°	
	15"	15°	19°	23°	27°	31°	35°	39°	43°	47°	51°	
	MK-7821 "Single" Actuator		135	108	90	77	68	60	54	49	45	42
	MK-7921 "Dual" Actuator		270	216	180	154	136	120	108	98	90	84

Force (lbs.) at 20 psig main air supply and Length of Driving Lever (L)

See reverse side for force in Newtons at 138 kPa (Table 3A)

Table 3A

Length of Driving Lever (L) mm

(Use shaded area to follow example in installation instructions.)

	101	127	152	178	203	229	254	279	305	330	
Length of Driven Lever (R) mm	101	60°	77°	97°	122°	180°					
	127	47°	60°	74°	89°	106°	128°	180°			
	152	39°	49°	60°	71°	84°	97°	113°	133°	180°	
	178	33°	42°	51°	60°	70°	80°	91°	104°	118°	
	203	29°	37°	44°	52°	60°	69°	77°	87°	97°	108°
	229	26°	32°	39°	46°	53°	60°	68°	75°	84°	93°
	254	23°	29°	35°	41°	47°	54°	60°	67°	74°	81°
	279	21°	26°	31°	37°	43°	48°	54°	60°	66°	73°
	305	19°	24°	29°	34°	39°	44°	49°	54°	60°	66°
	330	18°	22°	27°	31°	36°	41°	45°	50°	55°	60°
	356	16°	21°	25°	29°	33°	38°	42°	46°	51°	55°
381	15°	19°	23°	27°	31°	35°	39°	43°	47°	51°	
MK-7821 "Single" Actuator	600	480	400	342	302	267	240	218	200	187	
MK-7921 "Dual" Actuator	1200	960	800	684	604	534	480	436	400	374	

Force (N) at 138 kPa main air supply and Length of Driving Lever (L)

invensys®

Invensys Building Systems - Americas
 1354 Clifford Avenue (Zip 61111)
 P.O. Box 2940
 Loves Park, IL 31132-2940
 United States of America
www.invensysibs.com