

Application

The AV-352 valve linkage is used to field-install gear train actuators on specified 2-1/2" to 6" valve bodies.

Features

- Compatible with Invensys Building Systems 2-1/2" to 6" valves
- Provides increased close-off pressure on 2-1/2" to 4" valves
- Required for rated close-off pressure on 5" and 6" valves

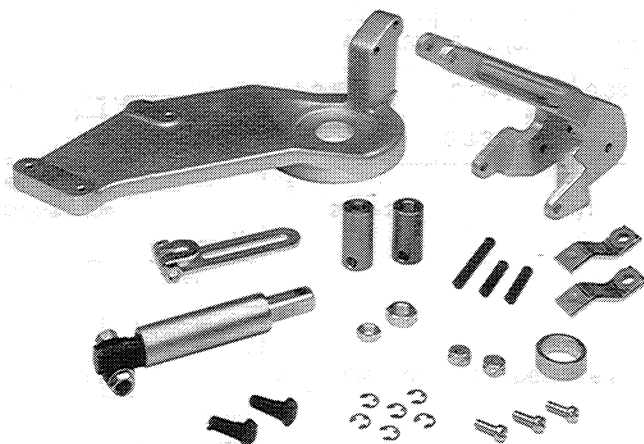

Applicable Literature

- Invensys Building Systems Cross-Reference Guide, F-23638
- Invensys Building Systems Reference Manual, F-21683
- Invensys Building Systems Application Manual, F-21335
- Invensys Building Systems Catalog, F-16650

SPECIFICATIONS

Close-Off Pressure Rating

Refer to Table-1 and Table-2 to make sure the valve, valve linkage, and actuator are compatible with each other, and that the close-off rating is adequate.

Table-1 Valve Close-Off Ratings, Pivot Pin Position, and Crank Arm Pivot Radius.

Valve Body Information				Close-Off Pressure* psi (kPa)	Pivot Pin Position	Approximate Crank Arm Pivot Radius in. (mm)
Valve Body Part Number	Description	C _v	Size in.			
VB-202-0-2-12	2-Way (Obsolete) 125 psig Flanged	56	2-1/2	112 (773)	1	2 (50.8)
VB-202-0-2-13		85	3	77 (531)	1	2 (50.8)
VB-202-0-2-14		145	4	42 (290)	1	2 (50.8)
VB-202-0-2-15		235	5	20 (138)	2	2-1/2 (63.5)
VB-202-0-2-16		350	6	14 (97)	2	2-1/2 (63.5)
VB-804-0-2-12	3-Way Mixing (Obsolete) 125 psig Flanged	74	2-1/2	112 (773)	1	2 (50.8)
VB-804-0-2-13		101	3	77 (531)	1	2 (50.8)
VB-804-0-2-14		170	4	42 (290)	1	2 (50.8)
VB-804-0-2-15		290	5	20 (138)	1	2-3/4 (69.8)
VB-804-0-2-16		390	6	14 (97)	2	2-1/8 (53.9)
VB-817-0-2-14	3-Way Diverting (Obsolete) 125 psig Flanged	"U" = 160, "L" = 180	4	125 (862)	1	2-1/4 (57.1)
VB-817-0-2-15		"U" = 195, "L" = 220	5	125 (862)	1	2-1/2 (63.5)
VB-817-0-2-16		"U" = 250, "L" = 275	6	125 (862)	2	2-1/8 (53.9)
VB-9213-0-4-12	2-Way (Current) 250 psig Screwed	56	2-1/2	112 (773)	1	2 (50.8)
VB-9213-0-4-13		85	3	77 (531)	1	2 (50.8)
VB-9213-0-5-12	2-Way (Current) 125 psig Flanged	56	2-1/2	112 (773)	1	2 (50.8)
VB-9213-0-5-13		85	3	77 (531)	1	2 (50.8)
VB-9213-0-5-14		145	4	42 (290)	1	2 (50.8)
VB-9213-0-5-15		235	5	20 (138)	2	2-1/2 (63.5)
VB-9213-0-5-16		350	6	14 (97)	2	2-1/2 (63.5)
VB-9313-0-4-12	3-Way Mixing (Current) 250 psig Screwed	74	2-1/2	112 (773)	1	2 (50.8)
VB-9313-0-4-13		101	3	77 (531)	1	2 (50.8)
VB-9313-0-5-12	3-Way Mixing (Current) 125 psig Flanged	74	2-1/2	112 (773)	1	2 (50.8)
VB-9313-0-5-13		101	3	77 (531)	1	2 (50.8)
VB-9313-0-5-14		170	4	42 (290)	1	2 (50.8)
VB-9313-0-5-15		290	5	20 (138)	2	2-1/2 (63.5)
VB-9313-0-5-16		390	6	14 (97)	2	2-1/2 (63.5)
VB-9323-0-5-14	3-Way Diverting (Current) 125 psig Flanged	"U" = 160, "L" = 180	4	125 (862)	1	2-1/4 (57.1)
VB-9323-0-5-15		"U" = 195, "L" = 220	5	125 (862)	1	2-1/2 (63.5)
VB-9323-0-5-16		"U" = 250, "L" = 275	6	125 (862)	2	2-1/8 (53.9)

* The actuator used must have a 180° travel and a minimum torque of 175 lb-in.

Typical Actuators: MC-351, MC-421, MC-431, MC-4311, MC5-4311, MP-381, MP-382, MP-451, MP-452, MP-481-600, MP-485, MP-486, MP-4851, and MP5-4851

Table-2 Pivot Pin Position and Crank Arm Pivot Radius for Valves Not Included in Table-1.

Valve Stroke (For Rated Flow) Stem Up to Stem Down in. (mm)	Required Linkage Lift Including 1/16" Compression on Valve Seats in. (mm)		Required Pivot Pin Position	Approximate Crank Arm Pivot Radius in. (mm)		Lever Ratio
	2-Way Valve	3-Way Valve		2-Way Valve	3-Way Valve	
1 (25.4)	1-1/16 (26.9)	1-1/8 (28.5)	1	2-1/8 (53.9)	2-1/4 (57.1)	0.252
1-1/8 (28.5)	1-3/16 (30.1)	1-1/4 (31.7)	1	2-3/8 (60.3)	2-1/2 (63.5)	0.252
1-1/4 (31.7)	1-5/16 (33.3)	1-3/8 (34.9)	1	2-5/8 (66.6)	2-3/4 (69.8)	0.252
1-3/8 (34.9)	1-7/16 (36.5)	1-1/2 (38.1)	1	2-7/8 (73)	3 (76.2)	0.252
1-1/2 (38.1)	1-9/16 (39.6)	1-5/8 (41.2)	2	2 (50.8)	2-1/8 (53.9)	0.385
1-3/4 (44.4)	1-13/16 (46)	1-7/8 (47.6)	2	2-3/8 (60.3)	2-1/2 (63.5)	0.385
2 (50.8)	2-1/16 (52.3)	2-1/8 (53.9)	2	2-5/8 (66.6)	2-3/4 (69.8)	0.385
2-1/4 (57.1)	2-5/16 (58.7)	2-3/8 (60.3)	2	3 (76.2)	3-3/32 (78.5)	0.385

For a 180° actuator: crank arm pivot radius = (required lift/2)/(lever ratio).

Example: If the required lift is 1-1/8", the crank arm pivot radius = (1.125/2)(0.252) = 2.232", or approximately 2-1/4".

Temperature Restrictions

Verify that the fluid temperature of the media in the valve and the ambient temperature at the actuator do not exceed the values shown in Table-3.

Table-3 Restrictions on the Maximum Ambient Temperature for the Actuators.

Maximum Temperature of Media in the Valve (Check Ratings of Valve)	Maximum Ambient Temperature for Actuator
260°F (126°C)	136°F (57°C)
281°F (138°C)	125°F (52°C)
300°F (149°C)	100°F (37°C)

Required Components

The actuators and the valves (see Table-1 and Table-2) must be purchased separately.

INSTALLATION

Inspection

Inspect the package for damage. If damaged, notify the appropriate carrier immediately. If undamaged, open the package and inspect the device for obvious damage. Return damaged products.

Requirements

- Tools (not provided):
 - Appropriate wrenches for stem extensions, locknuts, packing nuts, and bracket nuts
 - Appropriate screw driver for actuator mounting screws
- Training: Installer must be a qualified, experienced technician

Mounting

1. Install all two-way valves so that they close against the flow. An arrow on the valve body or a tag indicates the proper flow direction.
2. Install all three-way mixing valves with two inlets and one outlet.
3. Install all three-way diverting valves with one inlet and two outlets.
4. Actuators can be mounted in any upright position above the centerline of a valve body.
5. When selecting a location, allow sufficient room for accessories and for service of the product.

▼ CAUTION

Avoid locations where excessive moisture, corrosive fumes, or vibration is present.

ASSEMBLY PROCEDURE

NOTE

- Refer to Figure-1 during the assembly procedure for clarification, and for parts identification and layout. The item designators used in Figure-1 are referenced in parentheses throughout the assembly procedure.
- Refer to Figure-3 for mounting dimensions of the linkage assembly.

1. If the packing nut must be removed from the valve, first isolate the valve body, using shut-off valves, or reduce the system pressure on the valve to zero (0) psig. Then, drain all the fluid from the isolated or depressurized part of the system. Remove the packing nut from the valve.

▼ WARNING

Reduce the system pressure in the valve to zero (0) psig and drain all the fluid from the isolated or depressurized part of the system before removing the packing nut. Removing the packing nut while pressure exists in the valve may cause the packing parts to blow out of the valve, causing bodily injury or water damage.

2. Remove the bracket nut from the valve body.
3. If the valve bonnet is 1" (25.4 mm) in diameter, place the bonnet collar around it.
4. Position the mounting base (D) onto the valve body and secure it in place with the bracket nut. Replace the packing nut if it was removed.
5. Install the actuator (A) onto the mounting base (D), using the actuator mounting screws (B).
6. Assemble the two stem links (G) to the main arm (E), using the stem link studs (N) and the stem link nuts (P).
7. Screw the stem locknut (L) and the stem extension (K) well down onto the valve stem.
8. Determine the correct pivot pin location and the approximate crank arm pivot radius. Refer to Table-1 for applications using Barber-Colman valves. For applications using valves not listed in Table-1, refer to Table-2.



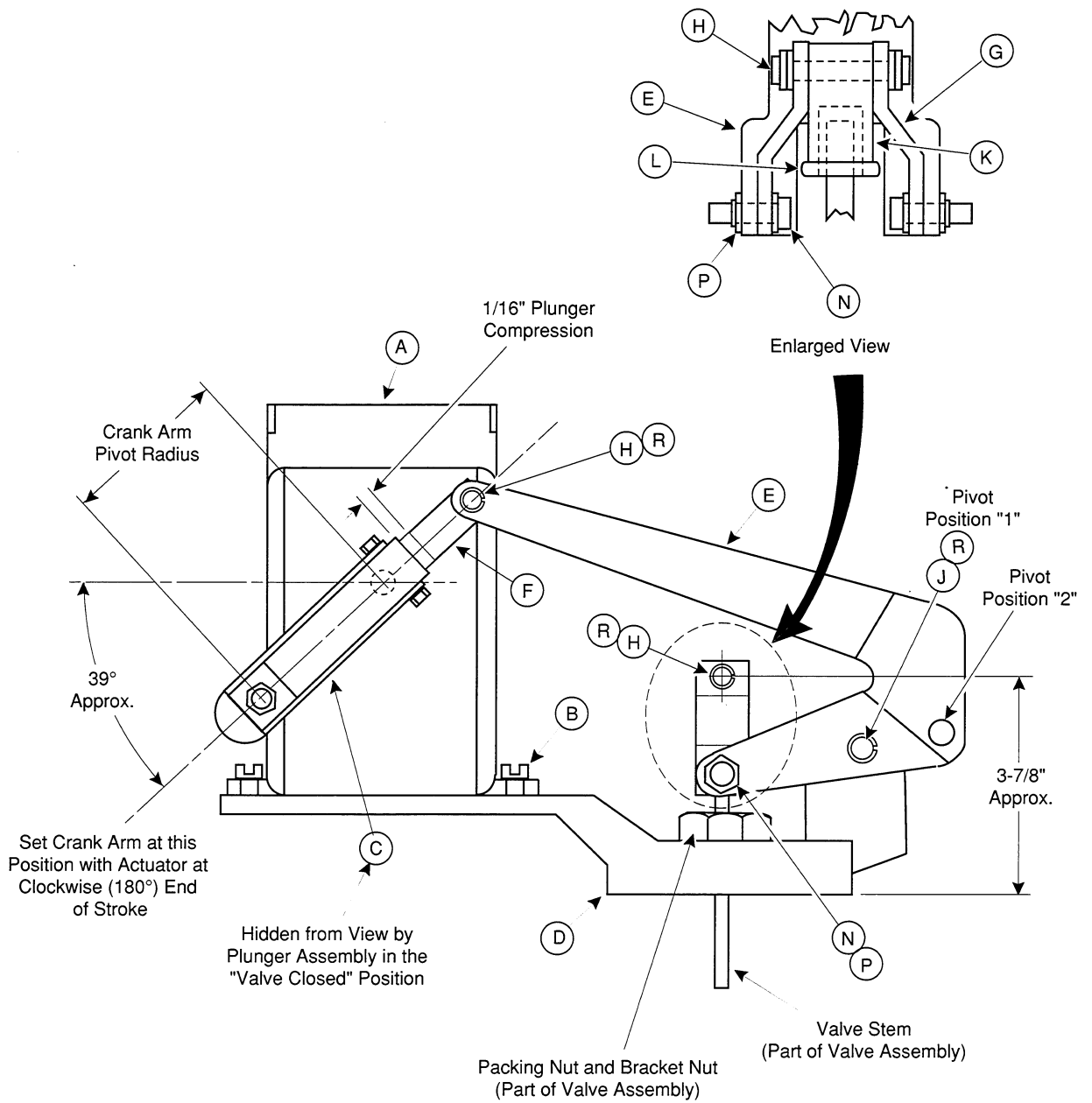

ITEM DESCRIPTIONS													
A	B	C	D	E	F	G	H	J	K	L	N	P	R
Act.	Act. Mtg Screw	Act. Crank Arm	Mtg Base	Main Arm	Plunger Assy.	Stem Link	Stem Link Pin	Main Arm Shaft	Stem Exten.	Stem Locknut	Stem Link Stud	Stem Link Nut	"E" Ring

Figure-1 AV-352 Valve Linkage Assembly.

9. Install the main arm (E) onto the mounting base (D) at the pivot position determined in the previous step, using the main arm shaft (J) and two "E" rings (R). Make sure that the innermost hole of the mounting base is used for pivot position "1" and the outermost hole is used for pivot position "2".
10. Operate the actuator to the full clockwise position (the short tooth on the actuator shaft is at the 9:00 position). See Figure-2.

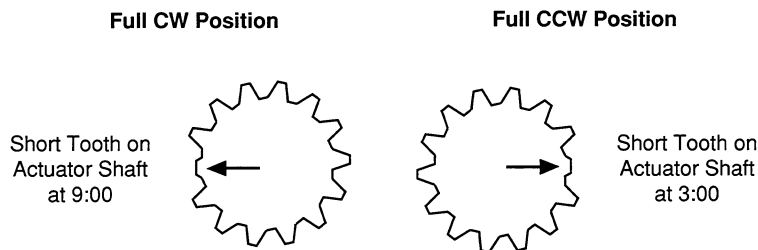

Figure-2 Actuator Shaft Position (Front View).

11. With the actuator at the full clockwise position, position the actuator crank arm (C) on the actuator output shaft at approximately 45°. Tap the actuator crank arm into place, and secure it with the locknut.
12. Install the plunger (F) onto the main arm (E), using the stem link pin (H) and two "E" rings (R).
13. Install the plunger (F) onto the actuator crank arm (C) at the pivot radius determined earlier.
14. With the valve stem fully down against the valve's bottom seat, turn the stem extension (K) until the hole in the stem extension aligns with the holes in the stem links (G). Then turn the stem extension CCW (upward), one full turn.
15. Operate the actuator (A), as necessary, to realign the holes in the stem extension (K) and stem links (G). Insert the stem link pin (H) into the holes, and secure it in place with two "E" rings (R).

NOTE

For MC actuators, remove the power from the actuator once the holes in the stem extension and stem links are realigned.

16. Adjust the plunger compression (see Figure-1) at the stem down position as follows:
 - a. Operate the actuator (A) to its full clockwise position (the short tooth on the actuator shaft is at the 9:00 position). See Figure-2. The valve stem should be fully down.
 - b. Check that the plunger compression is approximately 1/16" (1.6 mm).
 - c. If the plunger compression is less than required, increase it by turning the stem extension (K) counterclockwise.
 - d. If the plunger compression is more than required, decrease it by turning the stem extension (K) clockwise.

17. If the valve is a three-way type, adjust the plunger compression at the stem up position as follows:
 - a. Operate the actuator (A) to its full counterclockwise position (the short tooth on the actuator shaft is at the 3:00 position). See Figure-2. The valve stem should be fully up.
 - b. Check that the plunger compression is approximately 1/16" (1.6 mm).
 - c. If the plunger compression is less than required, increase it by increasing the crank arm pivot radius.
 - d. If the plunger compression is more than required, decrease it by decreasing the crank arm pivot radius.
 - e. If the crank arm pivot radius is changed, the stem extension must be readjusted to provide proper plunger compression on the valve's bottom seat. If readjustment is required, repeat the plunger compression adjustment procedure at the stem down position. This will ensure proper plunger compression in both the stem up and stem down positions.
18. When adjustment of the plunger compression is completed, tighten the stem locknut (L) against the stem extension (K) to secure the stem extension in position.

MAINTENANCE

The actuator linkage requires no maintenance.

Regular maintenance of the total system is recommended to assure sustained, optimum performance.

FIELD REPAIR

Individual parts of the actuator linkage are not repairable. Replace an inoperative actuator linkage with a functional unit.

DIMENSIONAL DATA

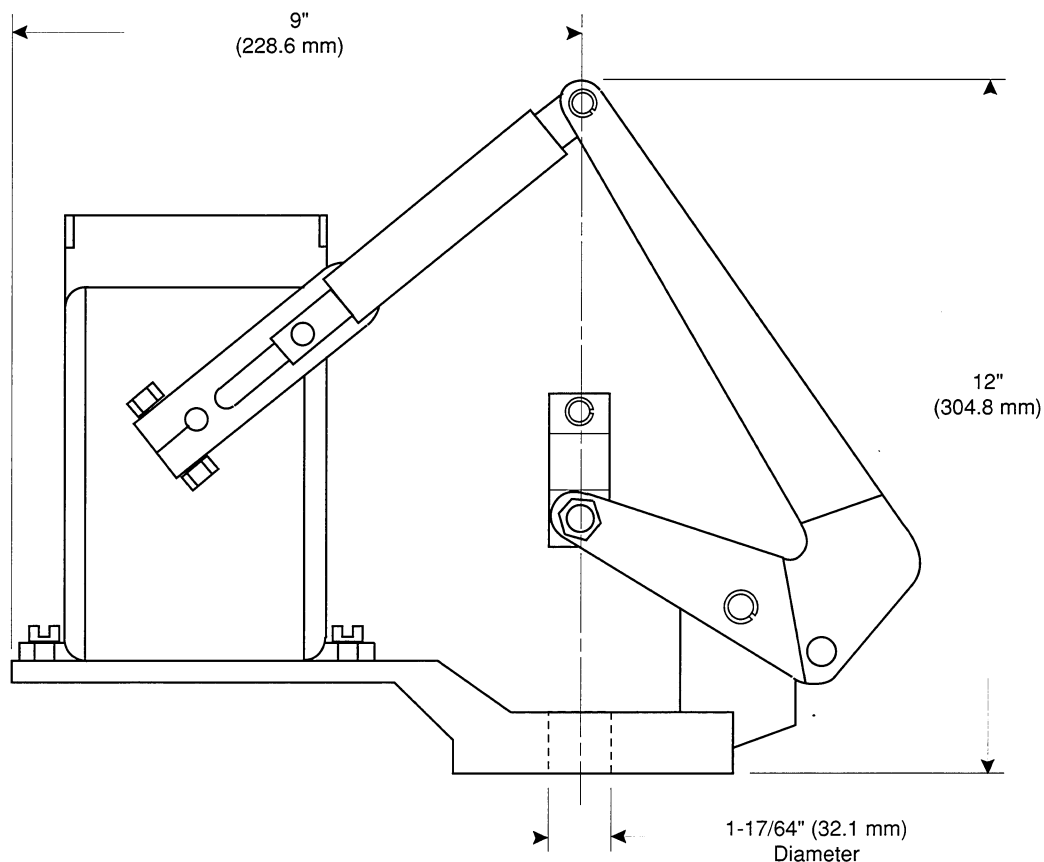

Figure-3 Mounting Dimensions of Valve Linkage Assembly.

