

## Application

The AV-630 series valve linkages are used to install VB-7XXX (1/2" to 2"), VB-9XXX (2-1/2" to 4"), or VB-9323 (2-1/2" and 3") valve bodies to MM-400 series non-spring return or MM-500 series spring return actuators.

## Features

- Provides interface between MM or MMR actuators and VB-series valves.
- Rugged metal construction.
- Valve position indication provided as standard.

## Applicable Literature

- Siebe Environmental Controls Cross-Reference Guide, F-23638
- Siebe Environmental Controls Reference Manual, F-21683
- Siebe Environmental Controls Application Manual, F-21335
- Siebe Environmental Controls Catalog, F-25683
- Siebe Environmental Controls Valve Selection Guide, F-26094

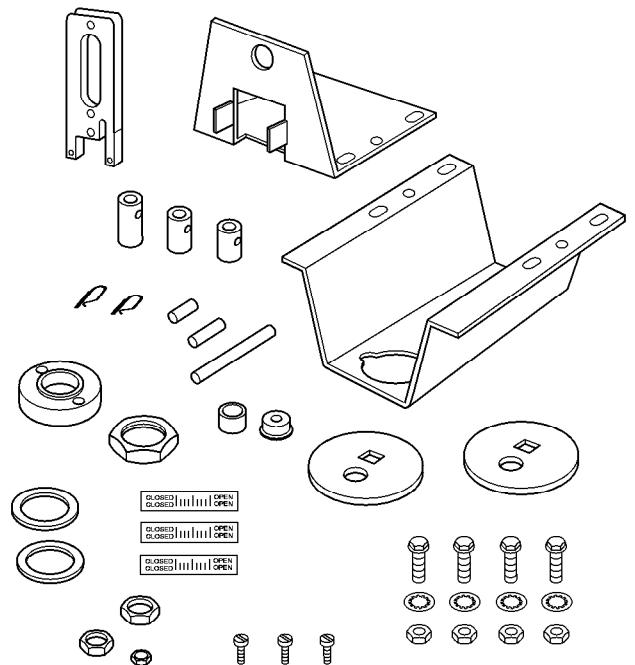

# SPECIFICATIONS

Table-1 Model Chart.

Parts Description	Quantity	VALVE LINKAGES				
		AV-630	AV-630-010	AV-630-020	AV-630-030	AV-630-040
		VALVE SIZES				
		All 1/2" to 4" VB-7XXX VB-9XXX	1/2" to 2" VB-7XXX 1/2" to 1-1/4" Obs. VB-9XXX	1-1/2" to 2" Obs. VB-9XXX	2-1/2" to 4" VB-9XXX except VB-9323	2-1/2" and 3" VB-9323 only
Mounting bracket	1	X	X	X	X	X
Mounting plate	1	X	X	X	X	X
Plunger	1	X	X	X	X	X
Actuator output shaft spacer	1	X	X	X	X	X
Adapter ring	1	X	X	X	X	X
Spring pins	2	X	X	X	X	X
Plunger retaining spacer	1	X	X	X	X	X
#8 x 1/2" Allen head plunger retaining spacer screw	1	X	X	X	X	X
1/4"-20 x 7/8" hexhead actuator mounting bolts	4	X	X	X	X	X
1/4"-20 nuts for mounting bolts	4	X	X	X	X	X
1/4" I.D. washers for mounting bolts	4	X	X	X	X	X
13/16" link rod	1	X		X		X
1-7/64" link rod	1	X			X	
2-27/32" link rod	1	X	X			
1/4" stem extension	1	X	X	X		
1/2" stem extension	1	X			X	
3/8" stem extension	1	X				X
1/4" stem extension locknut	1	X	X	X		
1/2" stem extension locknut	1	X			X	
3/8" stem extension locknut	1	X				X
190-40 plunger cam	1	X	X			
190-60 plunger cam	1	X		X	X	X
Fillister head screws	2	X	X	X		
1-1/2" O.D. washers	2	X				X
OPEN/CLOSED label, 1/2" lift	1	X	X			
OPEN/CLOSED label, 3/4" lift	1	X				X
OPEN/CLOSED label, 1" lift	1	X		X	X	
General Instructions sheet	1	X	X	X	X	X

## Close-off Pressure Rating

Refer to Table-2 to make sure that the valve, valve linkage, and actuator are compatible with each other and that the close-off rating is adequate. Verify that the valve body differential pressure is in compliance with the limitations specified for the valve being used with MM-400/500 actuators. Refer to **Siebe Environmental Controls Valve Selection Guide, F-26094**, for detailed information.

**Table-2 Valve and Linkage Selection for MM-400/500 Series Actuators with Resulting Close-off Pressures.**

VALVE BODY INFORMATION			CLOSE-OFF PRESSURE (psi)*			
Part Number	Description	Size	MM-500 Spring Return		MM-400 Non-Spring Return	
			Stem Up	Stem Down	Stem Up	Stem Down
VB-7213-0-4-X VB-7214-0-4-X VB-7215-0-4-X VB-7253-0-4-X VB-7273-0-4-X	2-Way	1/2"	—	250	—	250
		3/4"	—	130	—	250
		1"	—	72	—	250
		1-1/4"	—	45	—	166
		1-1/2"	—	30	—	116
		2"	—	16	—	65
		2-1/2"	—	10	—	42
VB-9213-0-X-X		3"	—	7	—	29
		4"	—	4	—	16
VB-7313-0-4-X VB-7314-0-4-X VB-7315-0-4-X	3-Way Mixing	1/2"	210	178	250	250
		3/4"	108	98	250	250
		1"	70	65	250	250
		1-1/4"	44	42	166	158
		1-1/2"	28	27	110	110
		2"	16	15	63	63
		2-1/2"	11	11	42	42
VB-9313-0-X-X		3"	8	8	29	29
		4"	4	4	16	16
VB-7323-0-4-X	3-Way Diverting	1/2"	250	250	250	250
		3/4"	250	250	250	250
		1"	250	250	250	250
		1-1/4"	250	250	250	250
		1-1/2"	250	250	250	250
		2"	250	250	250	250
VB-9323-0-5-X		2-1/2"	125	125	125	125
		3"	125	125	125	125

\*kPa = psi x 6.895

## Required Components

MM modular actuator, MMC control module, valve body, and certain accessories are required.

## INSTALLATION

### Inspection

Inspect the package for damage. If damaged, notify the appropriate carrier immediately. If undamaged, open the package and inspect the device for obvious damage. Return damaged products.

### Requirements

- Tools (not provided):
  - Two screwdrivers, heavy-duty and standard
  - Two crescent wrenches, large and small
  - Vise (optional) is desirable to aid the assembly of 1/2" to 2" valve bodies (make certain the vise jaws are placed on the end fitting of the valve body or damage may result, voiding the valve body warranty)
  - Allen head wrench set
- Training: Installer must be a qualified, experienced technician

### ▼ CAUTION

- Avoid locations where excessive moisture, corrosive fumes, or vibration is present.
- MM-400/500 series and MMC module General Instructions contain specific information on modular actuator installation and operation.
- AV-630-0X0 linkages are intended for mounting only the MM-400/500 series actuators to the valve bodies shown in Table-2.

## ASSEMBLY PROCEDURE

### Mounting 1/2" to 2" Two-Way VB-721X Valve Bodies and Three-Way Mixing and Diverting VB-73XX Valve Bodies to the "Load, Normally Closed-CCW Spring Return" End of MM-500 Series Actuators or the "Load" End of MM-400 Series Actuators

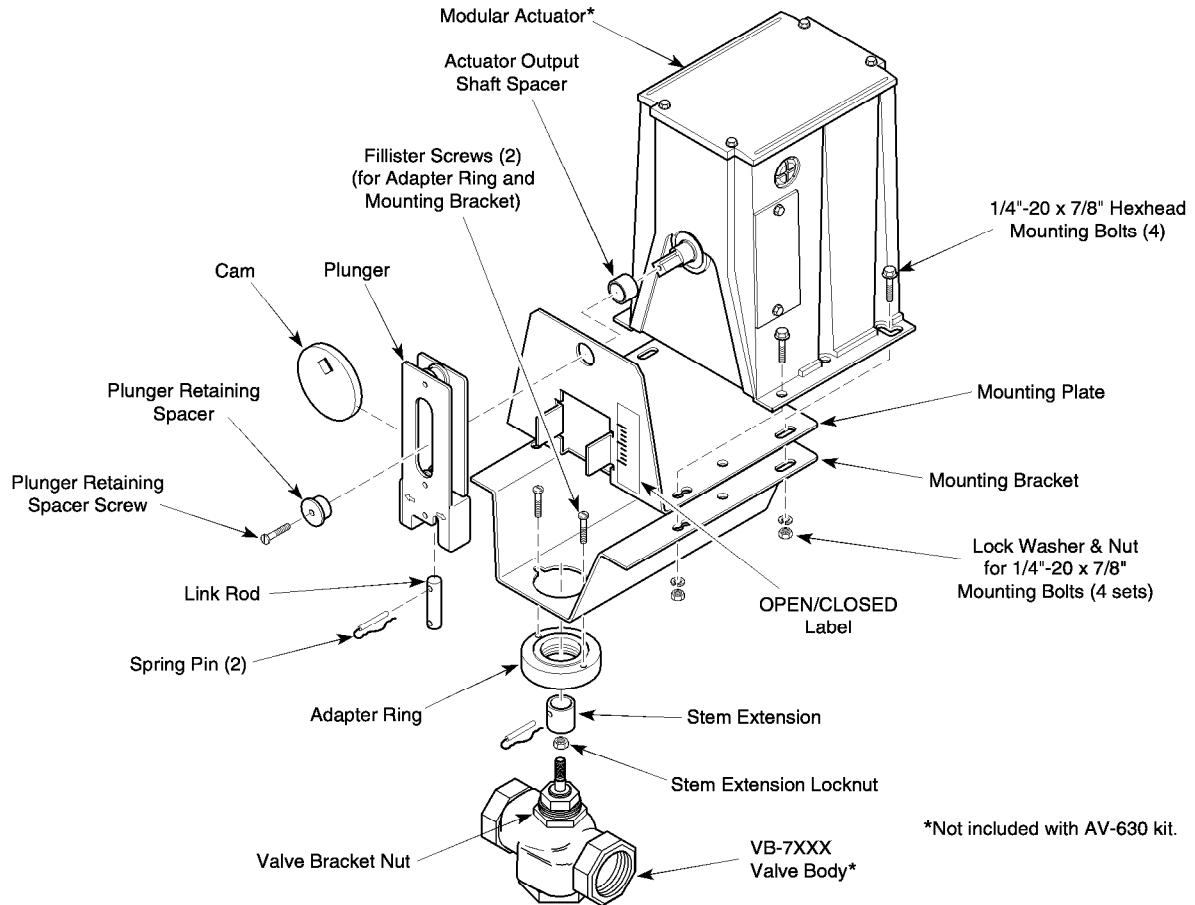

Figure-1 Assembly of AV-630 or AV-630-010 Valve Linkage with VB-7XXX Valve Body.

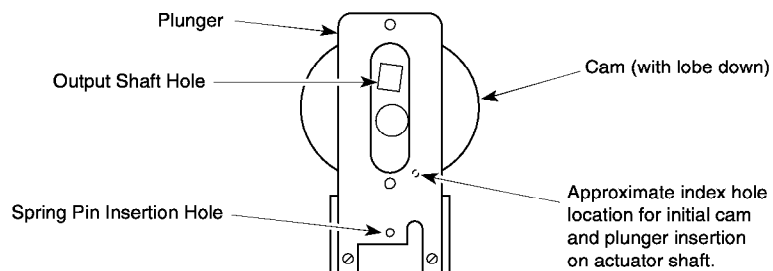

Figure-2 Initial Cam Installation Position for Valves Assembled to the "Load, Normally Closed-CCW Spring Return" or "Load" End of MM-400/500 Series Actuators.

See Table-2, Figure-1, and Figure-2.

1. Select the appropriate modular actuator, plug-in control module, valve body, and accessories.
2. Select the "Load, Normally Closed-CCW Spring Return" or "Load" end of the actuator.
3. Place the adapter ring on the underside of the valve mounting plate.

#### **NOTE**

Make certain that the ring shoulder is in the center of the mounting plate adapter hole. The female threads for the valve bonnet are accessible only from below.

4. Insert the two 1/2" long fillister head adapter ring screws through the ears of the mounting plate adapter hole and into the adapter ring, and secure.
5. Place the mounting plate on the mounting bracket.

**NOTE**

---

Make certain that the holes on the mounting bracket and mounting plate line up.

---

6. Place the output shaft spacer over the end of the actuator output shaft.

**NOTE**

---

The greater inside diameter of the spacer must rest against the retaining clip of the actuator output shaft.

---

7. Place the modular actuator on the mounting plate with the "Load, Normally Closed-CCW Spring Return" or "Load" end of the actuator output shaft through the hole in the mounting plate. The front holes of the actuator mounting base must line up with the front slotted holes of the mounting bracket and mounting plate.

**NOTE**

---

Make certain the mounting bracket and mounting plate hole alignment has not changed.

---

8. Insert four hexhead 1/4"-20 x 7/8" mounting bolts into the mounting base of the actuator and mounting bracket/plate assembly. Secure the actuator to the mounting bracket/plate assembly with bolts, washers, and nuts.
9. Select the cam marked 190-40.
10. With the word "POSITION" marked on the bottom of the plunger facing the installer, insert the cam into the plunger *with the cam part number facing the installer*. The cam square shaft hole must be located on the top of the plunger slot and the index hole located as shown in Figure-2.

**NOTE**

---

The cam edge must fit in the groove between the edges of the plunger rollers.

---

11. Slide the cam and plunger assembly over the actuator output shaft until the cam rests against the output shaft spacer.
12. Push the plunger retaining spacer onto the actuator output shaft and secure with the #8-32 x 1/2" self-locking Allen head retaining screw.
13. Insert the stem extension 2-27/32" (72 mm) link rod into the base of the plunger and secure with a spring pin.

**NOTE**

---

Make certain the spring pin goes through both sides of the plunger.

---

14. With the valve stem pushed completely down, thread the locknut for 1/4" dia. stem completely onto the valve stem.
15. Thread the stem extension for 1/4" dia. stem completely onto the valve stem.
16. Insert the top of the valve body (with stem extension and locknut installed) through the bottom of the adapter ring (assembled to the mounting bracket), and thread the valve bracket nut into the adapter ring to secure the valve body to the mounting bracket.
17. Stem extension adjustment:
  - a. Turn the stem extension CCW (as viewed from above) until the stem extension and stem extension link rod connecting pin holes line up.
  - b. Wire power and control signal to the modular actuator.
  - c. Run the actuator CW approximately 50% of travel.
  - d. Turn the stem extension 2-1/2 turns CCW (as viewed from above) until the stem extension connecting pin hole faces the installer.
  - e. Pull the valve stem up until the connecting pin holes in the stem extension link rod and stem extension line up.
  - f. Insert the spring pin all the way through the stem extension and stem extension link rod connecting pin holes.
18. Run the actuator fully CW until the actuator stops.
19. Tighten the stem extension locknut against the stem extension.
20. Run the actuator fully CCW until the actuator stops.

## NOTE

The index hole on the plunger cam does not normally return to its original position (as installed on the actuator output shaft). This assures proper close-off force on the valve stem. If sufficient close-off is not obtained, repeat steps 17 through 20, *except for step 17d*. Turn the stem extension an extra full turn CCW to provide additional compression. If sufficient close-off is still not obtained, check the valve stem and plug assembly for excessive wear. Replace the stem and plug components if required.

21. Place the 1/2" lift OPEN/CLOSED label on the mounting plate with the CLOSED mark next to the "POSITION" arrow on the plunger (OPEN mark away from the valve body) with the actuator in the fully CCW position.
22. Replace the top cover on the actuator.
23. Checkout:
  - a. The actuator should run freely through the complete stroke.
  - b. The linkage should operate without binding.
  - c. The valve must close off tightly at the bottom of the stroke (both ends of stroke on three-way application).
24. Linkage assembly is complete.

### Mounting 1-1/2" to 2" Obsolete Two-Way VB-921X Valve Bodies and Three-Way Mixing and Diverting Obsolete VB-93XX Valve Bodies to the "Load, Normally Closed-CCW Spring Return" End of MM-500 Series Actuators or the "Load" End of MM-400 Series Actuators

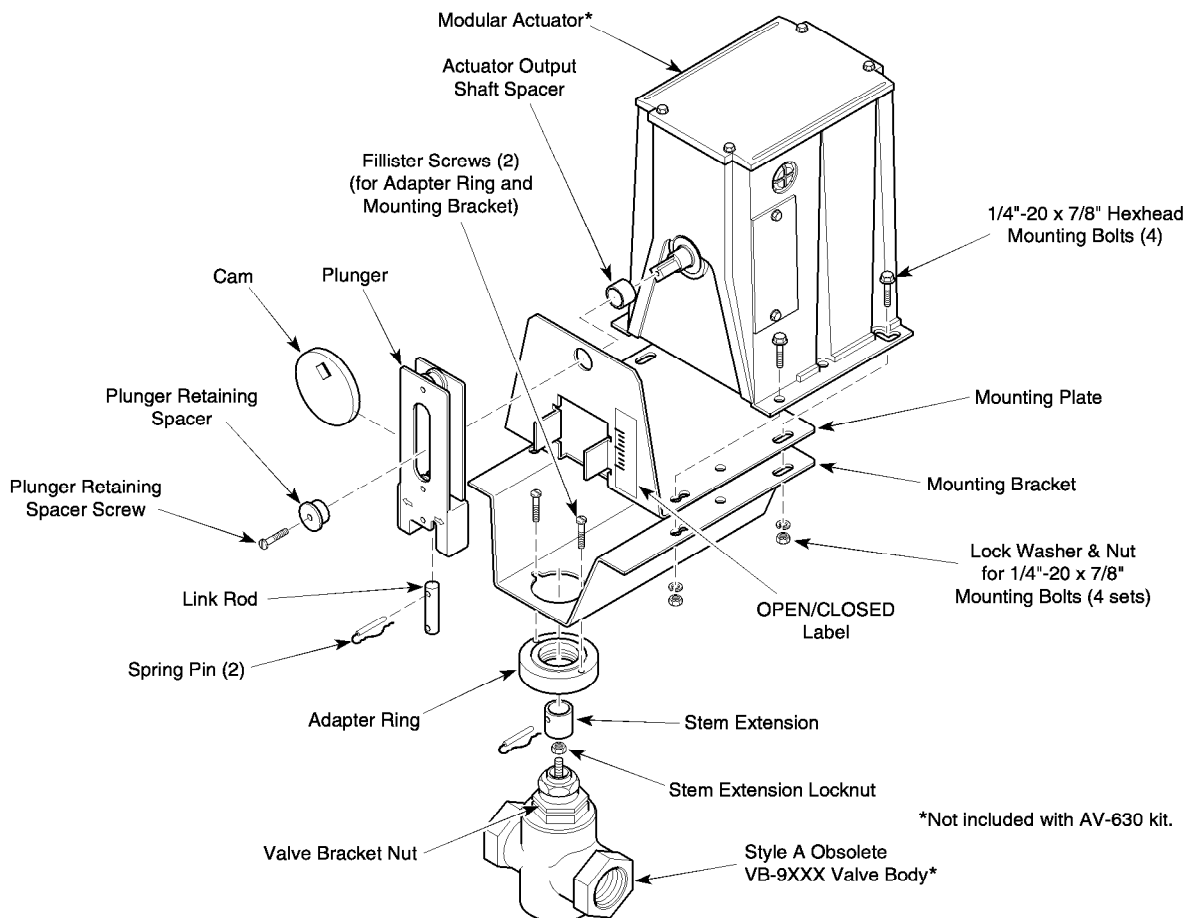

Figure-3 Assembly of AV-630 or AV-630-020 Valve Linkage with Style A Obsolete VB-9XXX Valve Body.

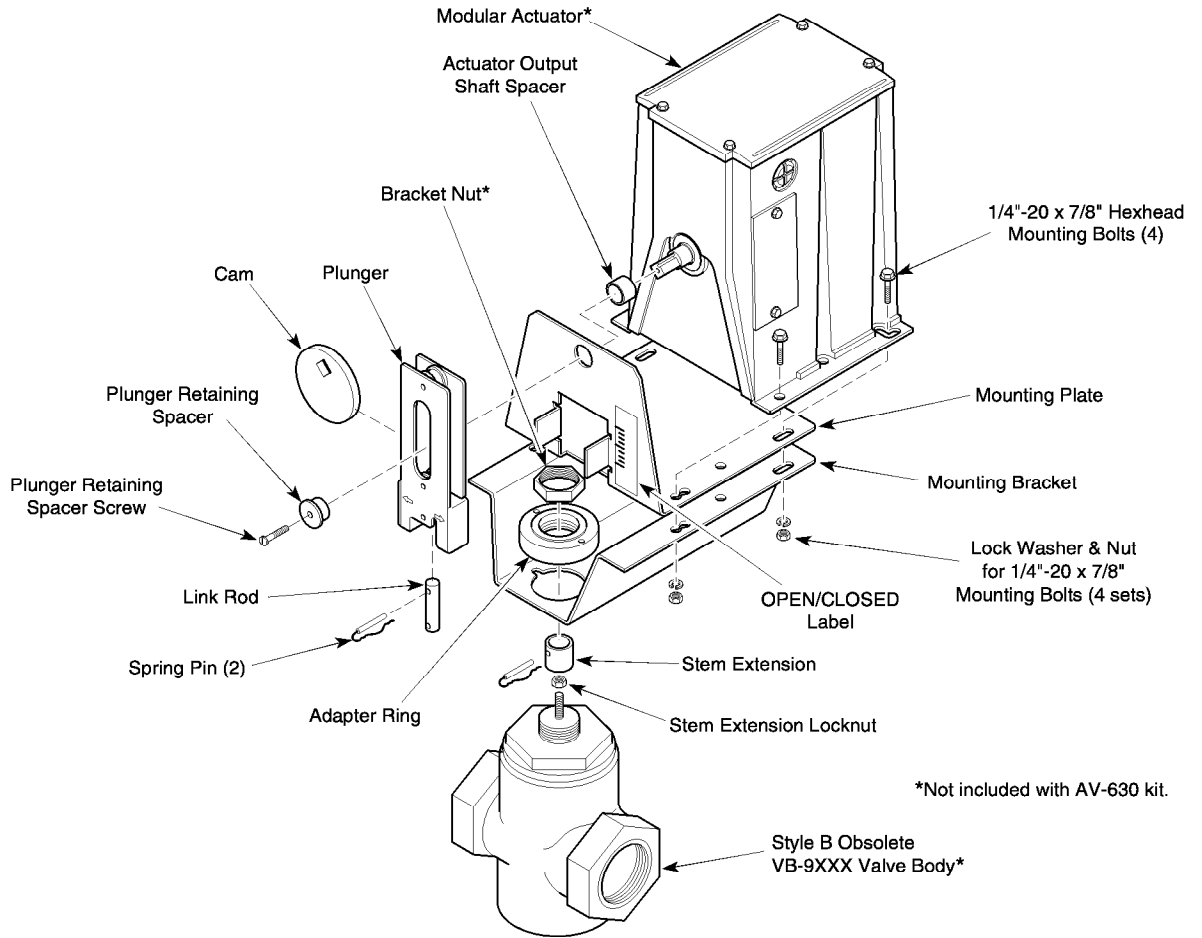

Figure-4 Assembly of AV-630 or AV-630-020 Valve Linkage with Style B Obsolete VB-9XXX Valve Body.

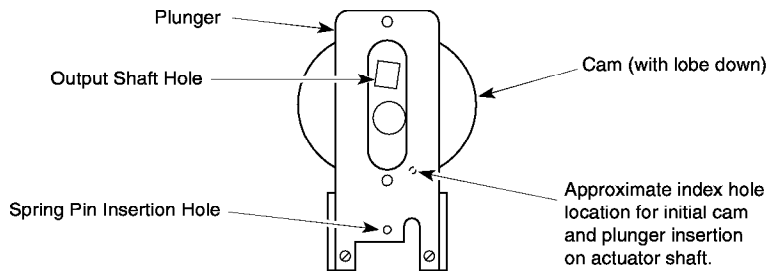

Figure-5 Initial Cam Installation Position for Valves Assembled to the “Load, Normally Closed–CCW Spring Return” or “Load” End of MM-400/500 Series Actuators.

See Table-2, Figure-3, Figure-4, and Figure-5.

1. Select the appropriate modular actuator, plug-in control module, valve body, and accessories.
2. Select the “Load, Normally Closed–CCW Spring Return” or “Load” end of the actuator.
3. For style A VB-9XXX valves only, place the adapter ring on the underside of the valve mounting plate. See Figure-3.

**NOTE**

Make certain that the ring shoulder is in the center of the mounting plate adapter hole. The female threads for the valve bonnet are accessible only from below.

4. For style A VB-9XXX valves only, insert the two 1/2" long fillister head adapter ring screws through the ears of the mounting plate adapter hole and into the adapter ring, and secure. See Figure-3.
5. Place the mounting plate on the mounting bracket.

**NOTE**

---

Make certain that the holes on the mounting bracket and mounting plate line up.

---

6. Place the output shaft spacer over the end of the actuator output shaft.

**NOTE**

---

The greater inside diameter of the spacer must rest against the retaining clip of the actuator output shaft.

---

7. Place the modular actuator on the mounting plate with the "Load, Normally Closed-CCW Spring Return" or "Load" end of the actuator output shaft through the hole in the mounting plate. The front holes of the actuator mounting base must line up with the front slotted holes of the mounting bracket and mounting plate.

**NOTE**

---

Make certain the mounting bracket and mounting plate hole alignment has not changed.

---

8. Insert four hexhead 1/4"-20 x 7/8" mounting bolts into the mounting base of the actuator and mounting bracket/plate assembly. Secure the actuator to the mounting bracket/plate assembly with bolts, washers, and nuts.
9. Select the cam marked 190-60.
10. With the word "POSITION" marked on the bottom of the plunger facing the installer, insert the cam into the plunger *with the cam part number facing the installer*. The cam square shaft hole must be located on the top of the plunger slot and the index hole located as shown in Figure-5.

**NOTE**

---

The cam edge must fit in the groove between the edges of the plunger rollers.

---

11. Slide the cam and plunger assembly over the actuator output shaft until the cam rests against the output shaft spacer.

**NOTE**

---

It may be necessary to place the stem extension link rod into the stem extension before sliding the cam onto the actuator output shaft.

---

12. Push the plunger retaining spacer onto the actuator output shaft and secure with the #8-32 x 1/2" self-locking Allen head retaining screw.
13. Insert the stem extension 13/16" (21 mm) link rod into the base of the plunger and secure with a spring pin.

**NOTE**

---

Make certain the spring pin goes through both sides of the plunger.

---

14. With the valve stem pushed completely down, thread the locknut for 1/4" dia. stem completely onto the valve stem.
15. Thread the stem extension for 1/4" dia. stem completely onto the valve stem.
16. For style A VB-9XXX valves only, insert the top of the valve body (with stem extension and locknut installed) through the bottom of the adapter ring (assembled to the mounting bracket), and thread the valve bracket nut into the adapter ring to secure the valve body to the mounting bracket.



17. For style B VB-9XXX valves only:
  - a. Place the mounting bracket on the valve body.
  - b. Place the adapter ring on the mounting bracket.

**NOTE**

---

Make certain that the ring shoulder is in the center of the mounting plate adapter hole. Adapter ring is used as a spacer only (mounting direction is optional).

---

- c. Thread the bracket nut onto the valve bonnet to secure the mounting bracket to the valve body.
18. Stem extension adjustment:
  - a. Turn the stem extension CCW (as viewed from above) until the stem extension and stem extension link rod connecting pin holes line up.
  - b. Wire power and control signal to the modular actuator.
  - c. Run the actuator CW approximately 50% of travel.
  - d. Turn the stem extension 2-1/2 turns CCW (as viewed from above) until the stem extension connecting pin hole faces the installer.
  - e. Pull the valve stem up until the connecting pin holes in the stem extension link rod and stem extension line up.
  - f. Insert the spring pin all the way through the stem extension and stem extension link rod connecting pin holes.
19. Run the actuator fully CW until the actuator stops.
20. Run the actuator fully CCW until the actuator stops.

**NOTE**

---

The index hole on the plunger cam does not normally return to its original position (as installed on the actuator output shaft). This assures proper close-off force on the valve stem. If sufficient close-off is not obtained, repeat steps 18 through 20 above, *except for step 18d*. Turn the stem extension an extra full turn CCW to provide additional compression. If sufficient close-off is still not obtained, check the valve stem and plug assembly for excessive wear. Replace the stem and plug components if required.

---

21. Tighten the stem extension locknut against the stem extension.
22. Place the 1" lift OPEN/CLOSED label on the mounting plate with the CLOSED mark next to the "POSITION" arrow on the plunger (OPEN mark away from the valve body) with the actuator in the fully CCW position.
23. Replace the top cover on the actuator.
24. Checkout:
  - a. The actuator should run freely through the complete stroke.
  - b. The linkage should operate without binding.
  - c. The valve must close off tightly at the bottom of the stroke (both ends of stroke on three-way application).
25. Linkage assembly is complete.

**Mounting 2-1/2" to 4" Two-Way VB-921X Valve Bodies and Three-Way Mixing VB-93XX Valve Bodies to the "Load, Normally Closed-CCW Spring Return" End of MM-500 Series Actuators or the "Load" End of MM-400 Series Actuators**

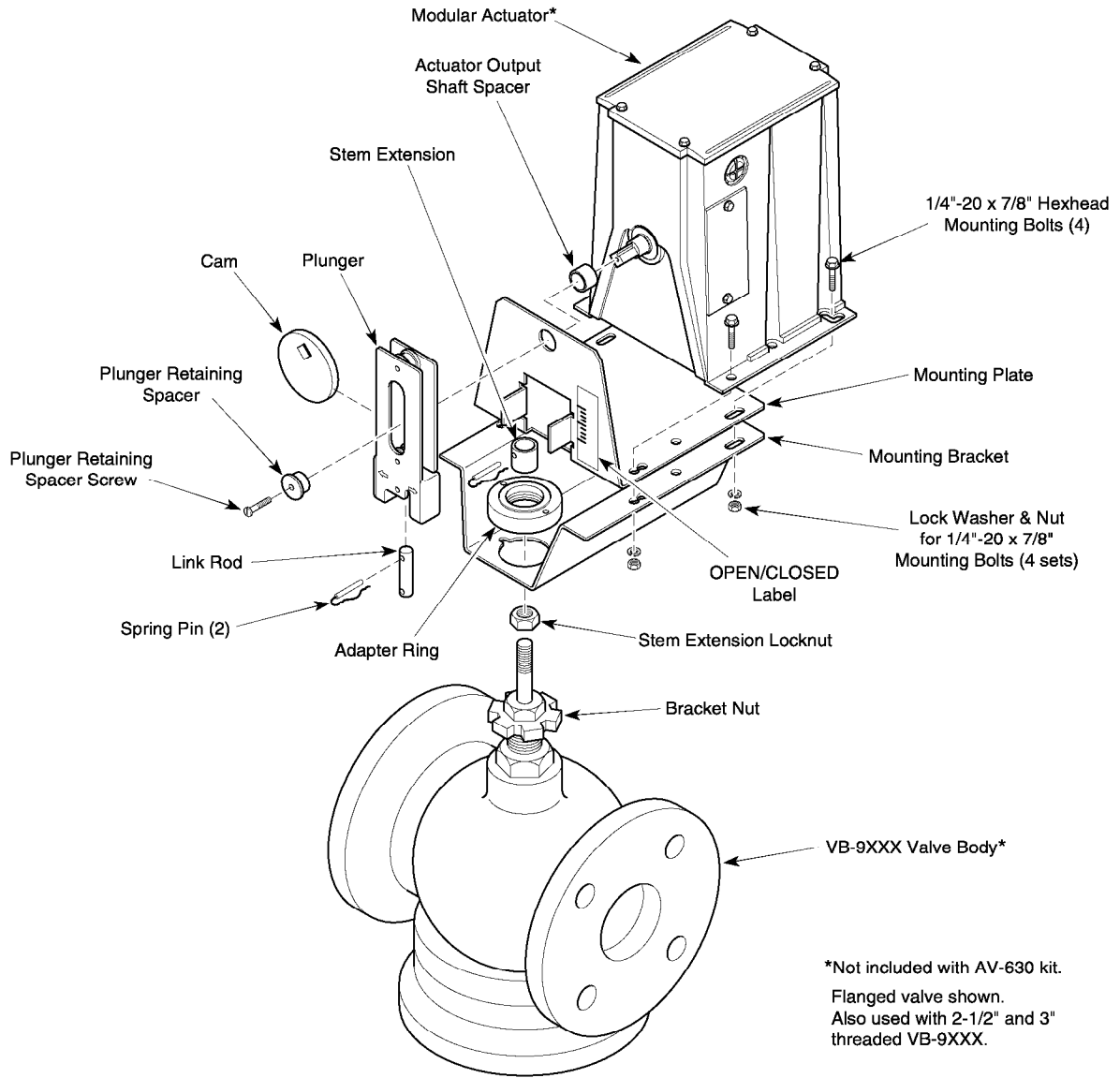

Figure-6 Assembly of AV-630 or AV-630-030 Valve Linkage with VB-9XXX Valve Body.

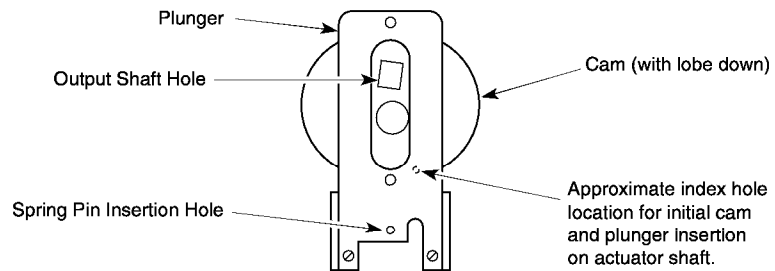

Figure-7 Initial Cam Installation Position for Valves Assembled to the "Load, Normally Closed-CCW Spring Return" or "Load" End of MM-400/500 Series Actuators.

See Table-2, Figure-6, and Figure-7.

1. Select the appropriate modular actuator, plug-in control module, valve body, and accessories.
2. Select the "Load, Normally Closed–CCW Spring Return" or "Load" end of the actuator.
3. Place the mounting plate on the mounting bracket.

**NOTE**

Make certain that the holes on the mounting bracket and mounting plate line up.

4. Place the output shaft spacer over the end of the actuator output shaft.

**NOTE**

The greater inside diameter of the spacer must rest against the retaining clip of the actuator output shaft.

5. Place the modular actuator on the mounting plate with the "Load, Normally Closed–CCW Spring Return" or "Load" end of the actuator output shaft through the hole in the mounting plate. The front holes of the actuator mounting base must line up with the front slotted holes of the mounting bracket and mounting plate.

**NOTE**

Make certain the mounting bracket and mounting plate hole alignment has not changed.

6. Insert four hexhead 1/4"-20 x 7/8" mounting bolts into the mounting base of the actuator and mounting bracket/plate assembly. Secure the actuator to the mounting bracket/plate assembly with bolts, washers, and nuts.
7. Select the cam marked 190-60.
8. With the word "POSITION" marked on the bottom of the plunger facing the installer, insert the cam into the plunger *with the cam part number facing the installer*. The cam square shaft hole must be located on the top of the plunger slot and the index hole located as shown in Figure-7.

**NOTE**

The cam edge must fit in the groove between the edges of the plunger rollers.

9. Slide the cam and plunger assembly over the actuator output shaft until the cam rests against the output shaft spacer.

**NOTE**

It may be necessary to place the stem extension link rod into the stem extension before sliding the cam onto the actuator output shaft.

10. Push the plunger retaining spacer onto the actuator output shaft and secure with the #8-32 x 1/2" self-locking Allen head retaining screw.
11. Insert the stem extension 1-7/64" (28 mm) link rod into the base of the plunger and secure with a spring pin.

**NOTE**

Make certain the spring pin goes through both sides of the plunger.

12. With the valve stem pushed completely down, thread the locknut for 1/2" dia. stem completely onto the valve stem.
13. Thread the stem extension for 1/2" dia. stem completely onto the valve stem.
14. Thread the bracket nut to the bottom of the valve bonnet.
15. Place the mounting bracket on the valve body and hold in place.

▼ **WARNING**

Any 2-1/2" to 4" VB-9XXX valve bodies date coded before 8603 must have the valve packing nut removed and replaced. Before removing the packing nut, isolate the valve body using shutoff valves or depressurize the system to zero gauge and drain the piping. The system pressure could cause packing parts to blow out with the potential of bodily injury and/or water damage.

16. Thread the adapter ring on the valve bonnet.
17. Thread the bracket nut up the valve bonnet to the bottom of the mounting bracket, securing the mounting bracket to the valve body.



18. Stem extension adjustment:
  - a. Turn the stem extension CCW (as viewed from above) until the stem extension and stem extension link rod connecting pin holes line up.
  - b. Wire power and control signal to the modular actuator.
  - c. Run the actuator CW approximately 50% of travel.
  - d. Turn the stem extension 2-1/2 turns CCW (as viewed from above) until the stem extension connecting pin hole faces the installer.
  - e. Pull the valve stem up (or drive the actuator) until the connecting pin holes in the stem extension link rod and stem extension line up.
  - f. Insert the spring pin all the way through the stem extension and stem extension link rod connecting pin holes.
19. Run the actuator fully CW until the actuator stops.
20. Run the actuator fully CCW until the actuator stops.

**NOTE**

---

The index hole on the plunger cam does not normally return to its original position (as installed on the actuator output shaft). This assures proper close-off force on the valve stem. If sufficient close-off is not obtained, repeat steps 18 through 20 above, *except for step 18d*. Turn the stem extension an extra full turn CCW to provide additional compression. If sufficient close-off is still not obtained, check the valve stem and plug assembly for excessive wear. Replace the stem and plug components if required.

---

21. Tighten the stem extension locknut against the stem extension.
22. Place the 1" lift OPEN/CLOSED label on the mounting plate with the CLOSED mark next to the "POSITION" arrow on the plunger (OPEN mark away from the valve body) with the actuator in the fully CCW position.
23. Replace the top cover on the actuator.
24. Checkout:
  - a. The actuator should run freely through the complete stroke.
  - b. The linkage should operate without binding.
  - c. The valve must close off tightly at the bottom of the stroke (both ends of stroke on three-way application).
25. Linkage assembly is complete.

**Mounting 2-1/2" and 3" Three-Way Diverting VB-9323 Valve Bodies to the "Load, Normally Closed-CCW Spring Return" End of MM-500 Series Actuators or the "Load" End of MM-400 Series Actuators**

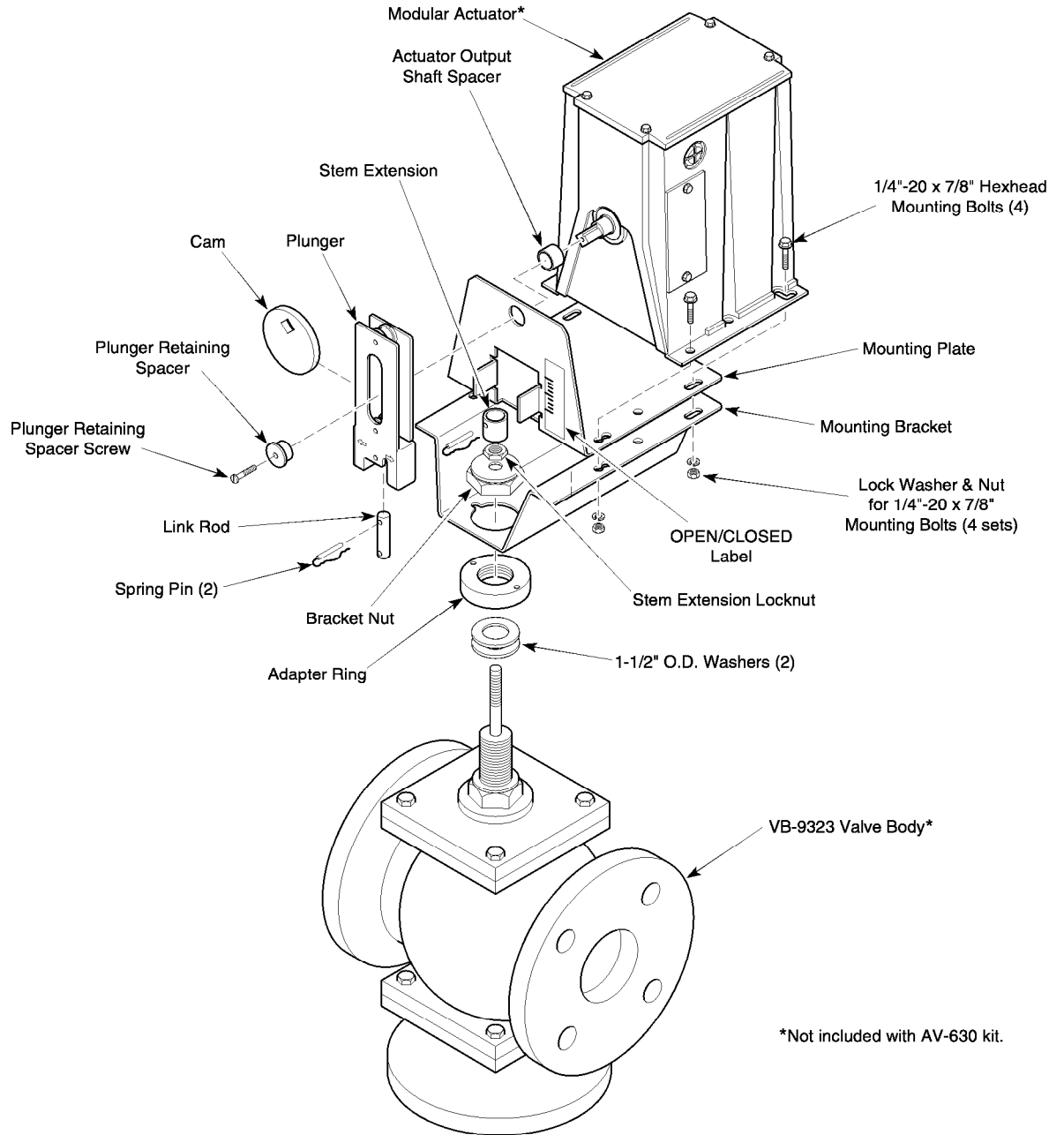

Figure-8 Assembly of AV-630 or AV-630-040 Valve Linkage with VB-9323 Valve Body.

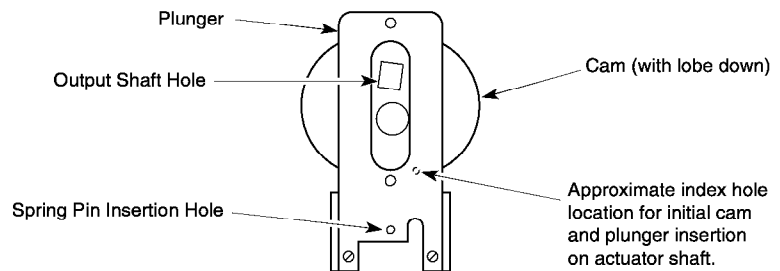

Figure-9 Initial Cam Installation Position for Valves Assembled to the "Load, Normally Closed-CCW Spring Return" or "Load" End of MM-400/500 Series Actuators.

See Table-2, Figure-8, and Figure-9.

1. Select the appropriate modular actuator, plug-in control module, valve body, and accessories.
2. Select the "Load, Normally Closed–CCW Spring Return" or "Load" end of the actuator.
3. Place the output shaft spacer over the end of the actuator output shaft.

---

**NOTE**

The greater inside diameter of the spacer must rest against the retaining clip of the actuator output shaft.

---

4. Place the modular actuator on the mounting plate with the "Load, Normally Closed–CCW Spring Return" or "Load" end of the actuator output shaft through the hole in the mounting plate. The front holes of the actuator mounting base must line up with the front slotted holes of the mounting bracket and mounting plate.

---

**NOTE**

Make certain the mounting bracket and mounting plate hole alignment has not changed.

---

5. Insert four hexhead 1/4"-20 x 7/8" mounting bolts into the mounting base of the actuator and mounting bracket/plate assembly. Secure the actuator to the mounting bracket/plate assembly with bolts, washers, and nuts.
6. Select the cam marked 190-60.
7. With the word "POSITION" marked on the bottom of the plunger facing the installer, insert the cam into the plunger *with the cam part number facing the installer*. The cam square shaft hole must be located on the top of the plunger slot and the index hole located as shown in Figure-9.

---

**NOTE**

The cam edge must fit in the groove between the edges of the plunger rollers.

---

8. Slide the cam and plunger assembly over the actuator output shaft until the cam rests against the output shaft spacer.

---

**NOTE**

It may be necessary to place the stem extension link rod into the stem extension before sliding the cam onto the actuator output shaft.

---

9. Push the plunger retaining spacer onto the actuator output shaft and secure with the #8-32 x 1/2" self-locking Allen head retaining screw.
10. Insert the stem extension 13/16" (21 mm) link rod into the base of the plunger and secure with a spring pin.

---

**NOTE**

Make certain the spring pin goes through both sides of the plunger.

---

11. With the valve stem pushed completely down, thread the locknut for 3/8" dia. stem completely onto the valve stem.
12. Thread the stem extension for 3/8" dia. stem completely onto the valve stem.
13. Remove the bracket nut that is provided with the valve body.
14. Place the two 1-1/2" dia. O.D. washers on the top of the valve.
15. Place the adapter ring, with the threads down, over the washers.
16. Place the mounting bracket on the adapter ring and hold in place.
17. Thread the bracket nut, with the shoulder up, completely onto the valve bonnet, securing the mounting bracket to the valve body.
18. Place the mounting plate on the mounting bracket.

---

**NOTE**

Make certain that the holes in the mounting bracket and mounting plate line up.

---

19. Stem extension adjustment:
  - a. Turn the stem extension CCW (as viewed from above) until the stem extension and stem extension link rod connecting pin holes line up.
  - b. Wire power and control signal to the modular actuator.
  - c. Run the actuator CW approximately 50% of travel.
  - d. Turn the stem extension 2-1/2 turns CCW (as viewed from above) until the stem extension connecting pin hole faces the installer.
  - e. Pull the valve stem up (or drive the actuator) until the connecting pin holes in the stem extension link rod and stem extension line up.
  - f. Insert the spring pin all the way through the stem extension and stem extension link rod connecting pin holes.
20. Run the actuator fully CW until the actuator stops.
21. Run the actuator fully CCW until the actuator stops.

**NOTE**

---

The index hole on the plunger cam does not normally return to its original position (as installed on the actuator output shaft). This assures proper close-off force on the valve stem. If sufficient close-off is not obtained, repeat steps 19 through 21 above, *except for step 19d*. Turn the stem extension an extra full turn CCW to provide additional compression. If sufficient close-off is still not obtained, check the valve stem and plug assembly for excessive wear. Replace the stem and plug components if required.

---

22. Tighten the stem extension locknut against the stem extension.
23. Place the 3/4" lift OPEN/CLOSED label on the mounting plate with the CLOSED mark next to the "POSITION" arrow on the plunger (OPEN mark away from the valve body) with the actuator in the fully CCW position.
24. Replace the top cover on the actuator.
25. Checkout:
  - a. The actuator should run freely through the complete stroke.
  - b. The linkage should operate without binding.
  - c. The valve must close off tightly at both ends of the stroke.
26. Linkage assembly is complete.

**Mounting 1/2" to 2" Two-Way VB-721X Valve Bodies and Three-Way Mixing and Diverting VB-73XX Valve Bodies to the "Optional, Normally Open-CW Spring Return" End of MM-500 Series Actuators or the "Optional" End of MM-400 Series Actuators**

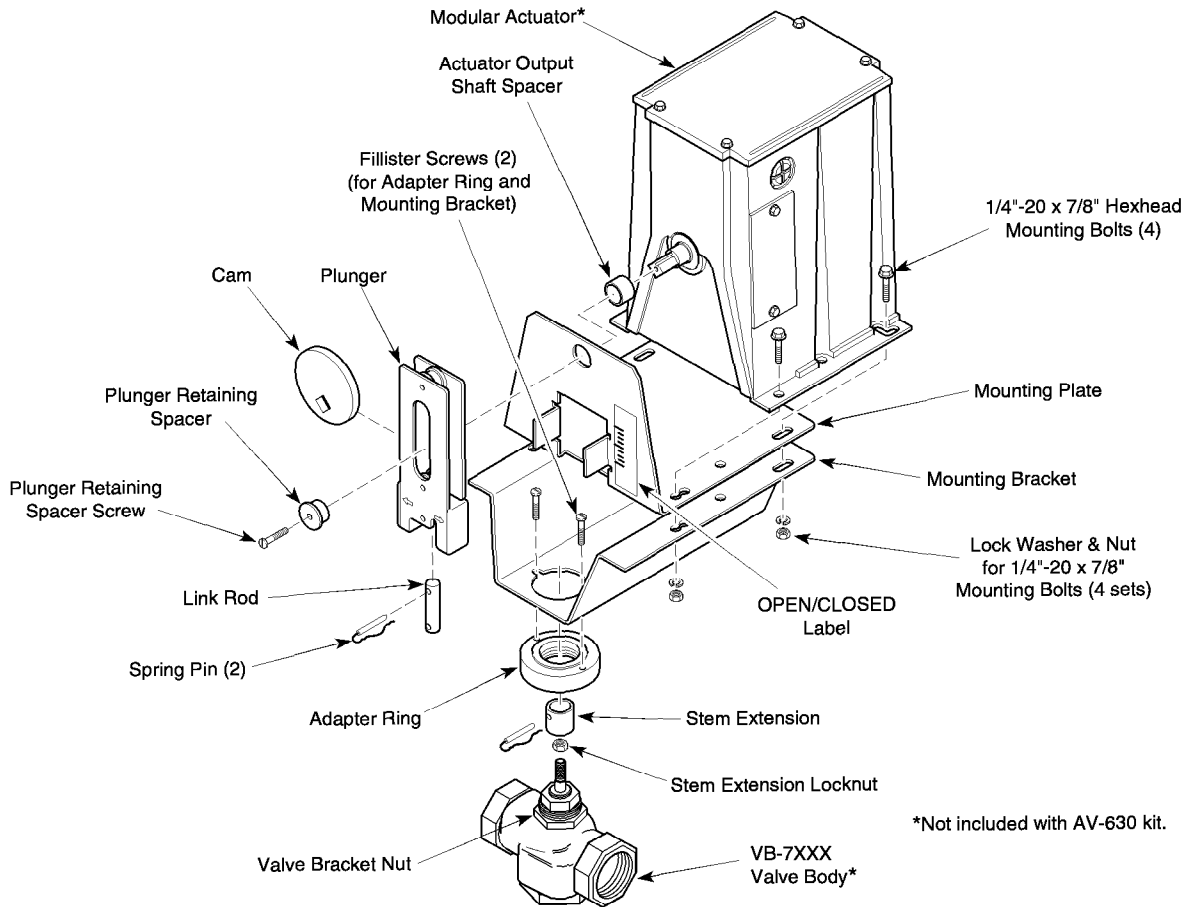

Figure-10 Assembly of AV-630 or AV-630-010 Valve Linkage with VB-7XXX Valve Body.

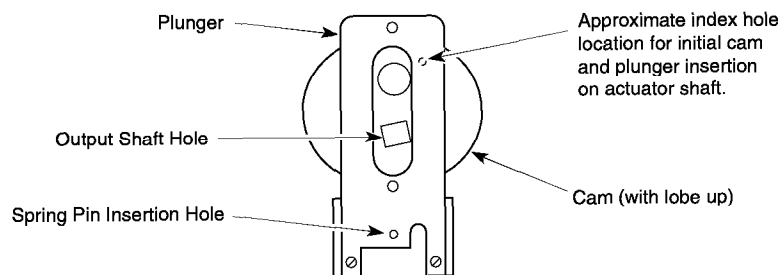

Figure-11 Initial Cam Installation Position for Valves Assembled to the "Optional, Normally Open-CW Spring Return" or "Optional" End of MM-400/500 Series Actuators.

See Table-2, Figure-10, and Figure-11.

1. Select the appropriate modular actuator, plug-in control module, valve body, and accessories.
2. Select the "Optional, Normally Open-CW Spring Return" or "Optional" end of the actuator.
3. Place the adapter ring on the underside of the valve mounting plate.

**NOTE**

Make certain that the ring shoulder is in the center of the mounting plate adapter hole. The female threads for the valve bonnet are accessible only from below.



4. Insert the two 1/2" long fillister head adapter ring screws through the ears of the mounting plate adapter hole and into the adapter ring, and secure.
5. Place the mounting plate on the mounting bracket.

**NOTE**

---

Make certain that the holes on the mounting bracket and mounting plate line up.

---

6. Place the output shaft spacer over the end of the actuator output shaft.

**NOTE**

---

The greater inside diameter of the spacer must rest against the retaining clip of the actuator output shaft.

---

7. Place the modular actuator on the mounting plate with the "Optional, Normally Open-CW Spring Return" or "Optional" end of the actuator output shaft through the hole in the mounting plate. The front slotted holes of the actuator mounting base must line up with the back end of the front slots of the mounting bracket and mounting plate.

**NOTE**

---

Make certain the mounting bracket and mounting plate hole alignment has not changed.

---

8. Insert four hexhead 1/4"-20 x 7/8" mounting bolts into the mounting base of the actuator and mounting bracket/plate assembly. Secure the actuator to the mounting bracket/plate assembly with bolts, washers, and nuts.
9. Select the cam marked 190-40.
10. With the word "POSITION" marked on the bottom of the plunger facing the installer, insert the cam into the plunger *with the cam part number facing the actuator*. The cam square shaft hole must be located on the bottom of the plunger slot and the index hole located as shown in Figure-11.

**NOTE**

---

The cam edge must fit in the groove between the edges of the plunger rollers.

---

11. Slide the cam and plunger assembly over the actuator output shaft until the cam rests against the output shaft spacer.
12. Push the plunger retaining spacer onto the actuator output shaft and secure with the #8-32 x 1/2" self-locking Allen head retaining screw.
13. Insert the stem extension 2-27/32" (72 mm) link rod into the base of the plunger and secure with a spring pin.

**NOTE**

---

Make certain the spring pin goes through both sides of the plunger.

---

14. With the valve stem pushed completely down, thread the locknut for 1/4" dia. stem completely onto the valve stem.
15. Thread the stem extension for 1/4" dia. stem completely onto the valve stem.
16. Insert the top of the valve body (with stem extension and locknut installed) through the bottom of the adapter ring (assembled to the mounting bracket), and thread the valve bracket nut into the adapter ring to secure the valve body to the mounting bracket.
17. Stem extension adjustment:
  - a. Wire power and control signal to the modular actuator.
  - b. Run the actuator CCW to end of travel.
  - c. Turn the stem extension CCW (as viewed from above) until the stem extension and stem extension link rod connecting pin holes line up.
  - d. Run the actuator CW approximately 50% of travel.
  - e. Turn the stem extension 2-1/2 turns CCW (as viewed from above) until the stem extension connecting pin hole faces the installer.
  - f. Pull the valve stem up until the connecting pin holes in the stem extension link rod and stem extension line up.
  - g. Insert the spring pin all the way through the stem extension and stem extension link rod connecting pin holes.
18. Run the actuator fully CW until the actuator stops.
19. Run the actuator fully CCW until the actuator stops.

**NOTE**

The index hole on the plunger cam does not normally return to its original position (as installed on the actuator output shaft). This assures proper close-off force on the valve stem. If sufficient close-off is not obtained, repeat steps 17 through 19 above, *except for step 17e*. Turn the stem extension an extra full turn CCW to provide additional compression. If sufficient close-off is still not obtained, check the valve stem and plug assembly for excessive wear. Replace the stem and plug components if required.

20. Tighten the stem extension locknut against the stem extension.
21. Place the 1/2" lift OPEN/CLOSED label on the mounting plate with the OPEN mark next to the "POSITION" arrow on the plunger (CLOSED mark toward the valve body) with the actuator in the fully CW position.
22. Replace the top cover on the actuator.
23. Checkout:
  - a. The actuator should run freely through the complete stroke.
  - b. The linkage should operate without binding.
  - c. The valve must close off tightly at the bottom of the stroke (both ends of stroke on three-way application).
24. Linkage assembly is complete.

**Mounting 1-1/2" to 2" Obsolete Two-Way VB-921X Valve Bodies and Three-Way Mixing and Diverting Obsolete VB-93XX Valve Bodies to the "Optional, Normally Open-CW Spring Return" End of MM-500 Series Actuators or the "Optional" End of MM-400 Series Actuators**

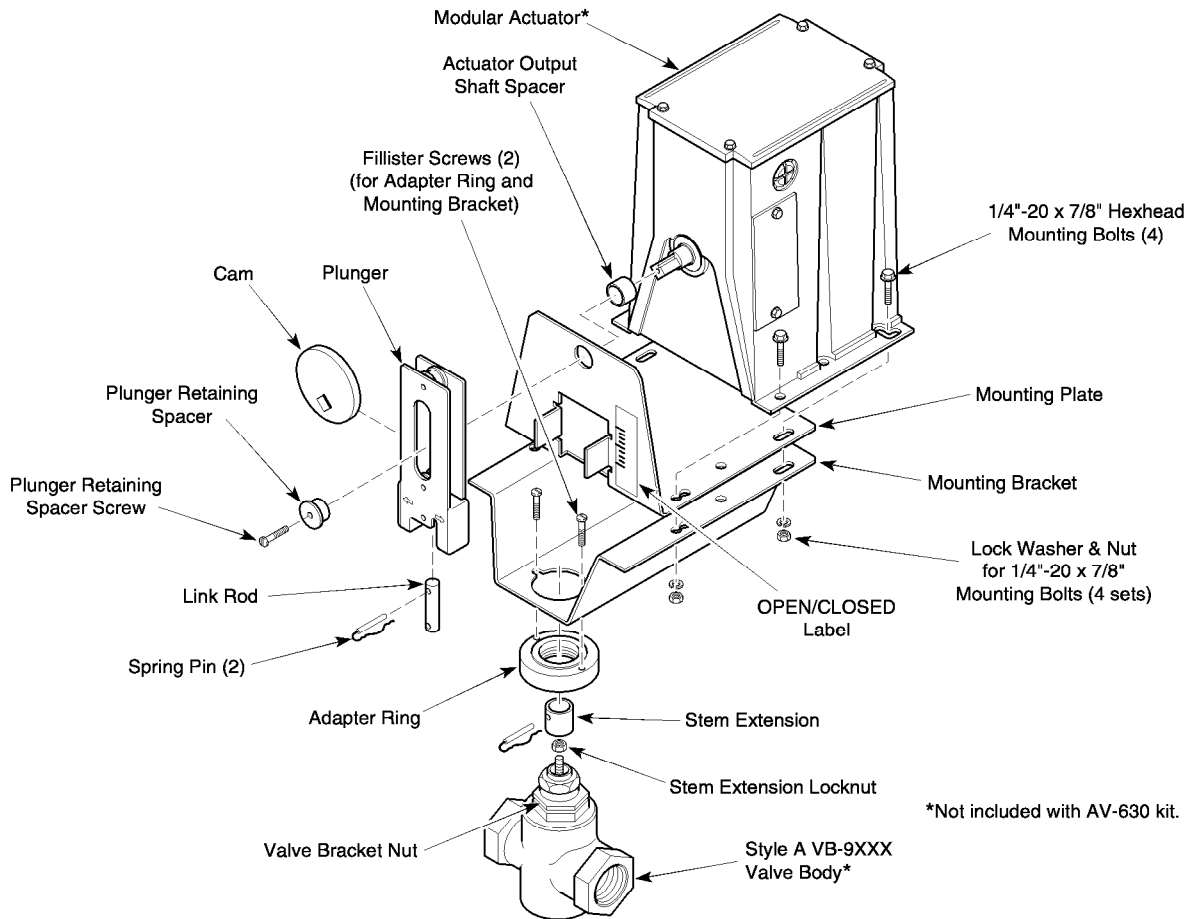

Figure-12 Assembly of AV-630 or AV-630-020 Valve Linkage with Style A VB-9XXX Valve Body.

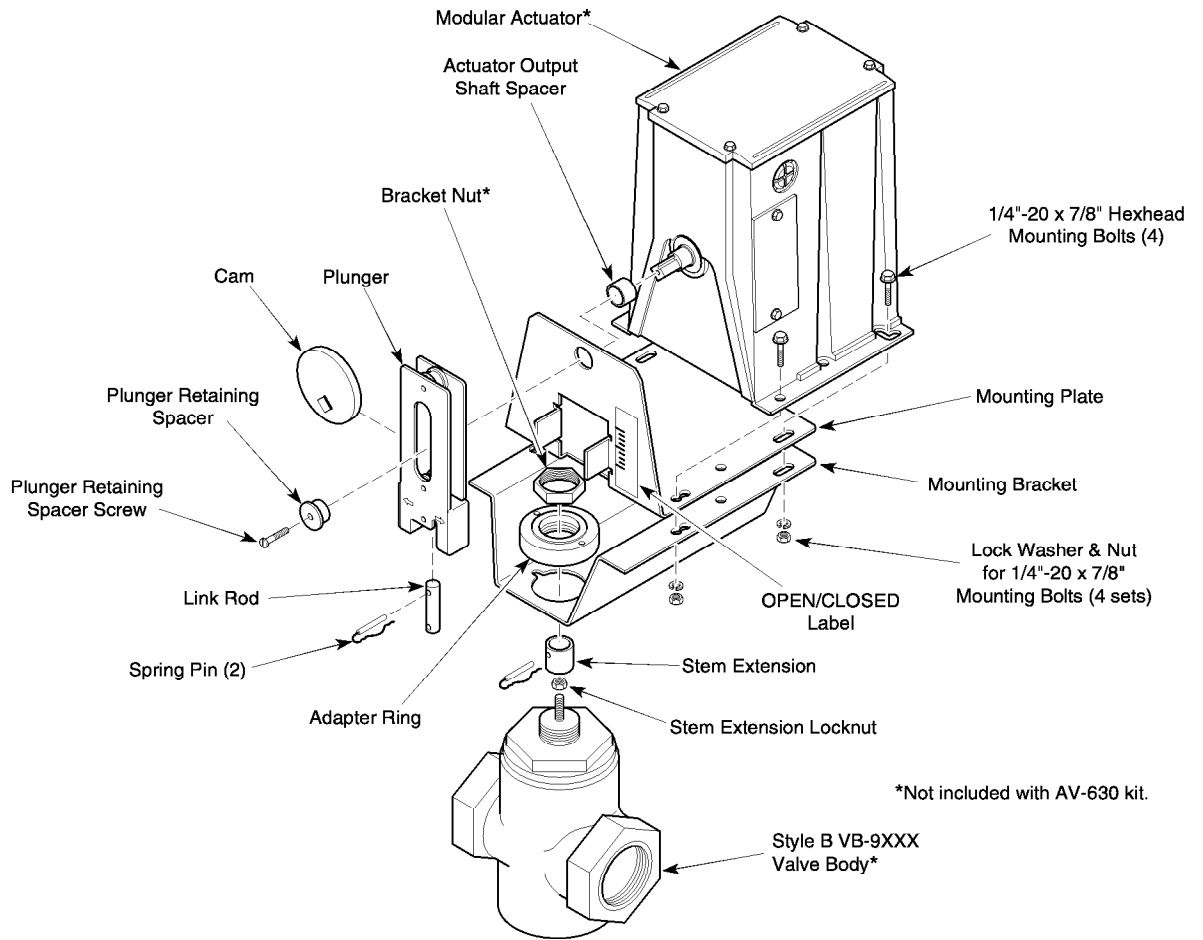

Figure-13 Assembly of AV-630 or AV-630-020 Valve Linkage with Style B VB-9XXX Valve Body.

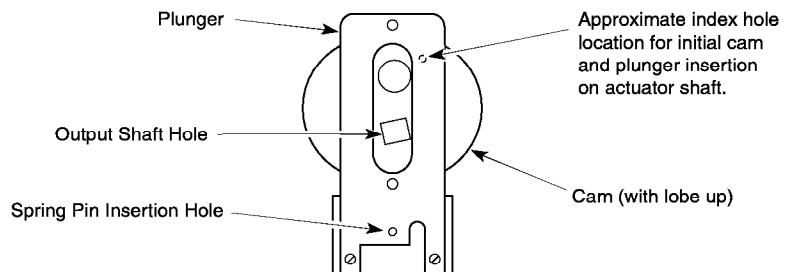

Figure-14 Initial Cam Installation Position for Valves Assembled to the "Optional, Normally Open-CW Spring Return" or "Optional" End of MM-400/500 Series Actuators.

See Table-2, Figure-12, Figure-13, and Figure-14.

1. Select the appropriate modular actuator, plug-in control module, valve body, and accessories.
2. Select the "Optional, Normally Open-CW Spring Return" or "Optional" end of the actuator.
3. For style A VB-9XXX valves only, place the adapter ring on the underside of the valve mounting plate. See Figure-12.

**NOTE**

Make certain that the ring shoulder is in the center of the mounting plate adapter hole. The female threads for the valve bonnet are accessible only from below.

4. For style A VB-9XXX valves only, insert the two 1/2" long fillister head adapter ring screws through the ears of the mounting plate adapter hole and into the adapter ring, and secure. See Figure-12.
5. Place the mounting plate on the mounting bracket.

---

**NOTE**

Make certain that the holes on the mounting bracket and mounting plate line up.

---

6. Place the output shaft spacer over the end of the actuator output shaft.

---

**NOTE**

The greater inside diameter of the spacer must rest against the retaining clip of the actuator output shaft.

---

7. Place the modular actuator on the mounting plate with the "Optional, Normally Open-CW Spring Return" or "Optional" end of the actuator output shaft through the hole in the mounting plate. The front slotted holes of the actuator mounting base must line up with the back end of the front slots of the mounting bracket and mounting plate.

---

**NOTE**

Make certain the mounting bracket and mounting plate hole alignment has not changed.

---

8. Insert four hexhead 1/4"-20 x 7/8" mounting bolts into the mounting base of the actuator and mounting bracket/plate assembly. Secure the actuator to the mounting bracket/plate assembly with bolts, washers, and nuts.
9. Select the cam marked 190-60.
10. With the word "POSITION" marked on the bottom of the plunger facing the installer, insert the cam into the plunger *with the cam part number facing the actuator*. The cam square shaft hole must be located on the bottom of the plunger slot and the index hole located as shown in Figure-14.

---

**NOTE**

The cam edge must fit in the groove between the edges of the plunger rollers.

---

11. Slide the cam and plunger assembly over the actuator output shaft until the cam rests against the output shaft spacer.

---

**NOTE**

It may be necessary to place the stem extension link rod into the stem extension before sliding the cam onto the actuator output shaft.

---

12. Push the plunger retaining spacer onto the actuator output shaft and secure with the #8-32 x 1/2" self-locking Allen head retaining screw.
13. Insert the stem extension 13/16" (21 mm) link rod into the base of the plunger and secure with a spring pin.

---

**NOTE**

Make certain the spring pin goes through both sides of the plunger.

---

14. With the valve stem pushed completely down, thread the locknut for 1/4" dia. stem completely onto the valve stem.
15. Thread the stem extension for 1/4" dia. stem completely onto the valve stem.
16. For style A VB-9XXX valves only, insert the top of the valve body (with stem extension and locknut installed) through the bottom of the adapter ring (assembled to the mounting bracket), and thread the valve bracket nut into the adapter ring to secure the valve body to the mounting bracket.
17. For style B VB-9XXX valves only:
  - a. Place the mounting bracket on the valve body.
  - b. Place the adapter ring on the mounting bracket.

---

**NOTE**

Make certain that the ring shoulder is in the center of the mounting plate adapter hole. Adapter ring is used as a spacer only (mounting direction is optional).

---

- c. Thread the bracket nut onto the valve bonnet to secure the mounting bracket to the valve body.

18. Stem extension adjustment:
  - a. Wire power and control signal to the modular actuator.
  - b. Run the actuator CCW to the end of travel.
  - c. Turn the stem extension CCW (as viewed from above) until the stem extension and stem extension link rod connecting pin holes line up.
  - d. Run the actuator CW approximately 50% of travel.
  - e. Turn the stem extension 2-1/2 turns CCW (as viewed from above) until the stem extension connecting pin hole faces the installer.
  - f. Pull the valve stem up until the connecting pin holes in the stem extension link rod and stem extension line up.
  - g. Insert the spring pin all the way through the stem extension and stem extension link rod connecting pin holes.
19. Run the actuator fully CW until the actuator stops.
20. \*Run the actuator fully CCW until the actuator stops.

**NOTE**

---

The index hole on the plunger cam does not normally return to its original position (as installed on the actuator output shaft). This assures proper close-off force on the valve stem. If sufficient close-off is not obtained, repeat steps 18 through 20 above, *except for step 18e*. Turn the stem extension an extra full turn CCW to provide additional compression. If sufficient close-off is still not obtained, check the valve stem and plug assembly for excessive wear. Replace the stem and plug components if required.

---

21. Tighten the stem extension locknut against the stem extension.
22. Place the 1" lift OPEN/CLOSED label on the mounting plate with the OPEN mark next to the "POSITION" arrow on the plunger (CLOSED mark toward the valve body) with the actuator in the fully CW position.
23. Replace the top cover on the actuator.
24. Checkout:
  - a. The actuator should run freely through the complete stroke.
  - b. The linkage should operate without binding.
  - c. The valve must close off tightly at the bottom of the stroke (both ends of stroke on three-way application).
25. Linkage assembly is complete.

**Mounting 2-1/2" to 4" Two-Way VB-921X Valve Bodies and Three-Way Mixing VB-93XX Valve Bodies to the "Optional, Normally Open-CW Spring Return" End of MM-500 Series Actuators or the "Optional" End of MM-400 Series Actuators**

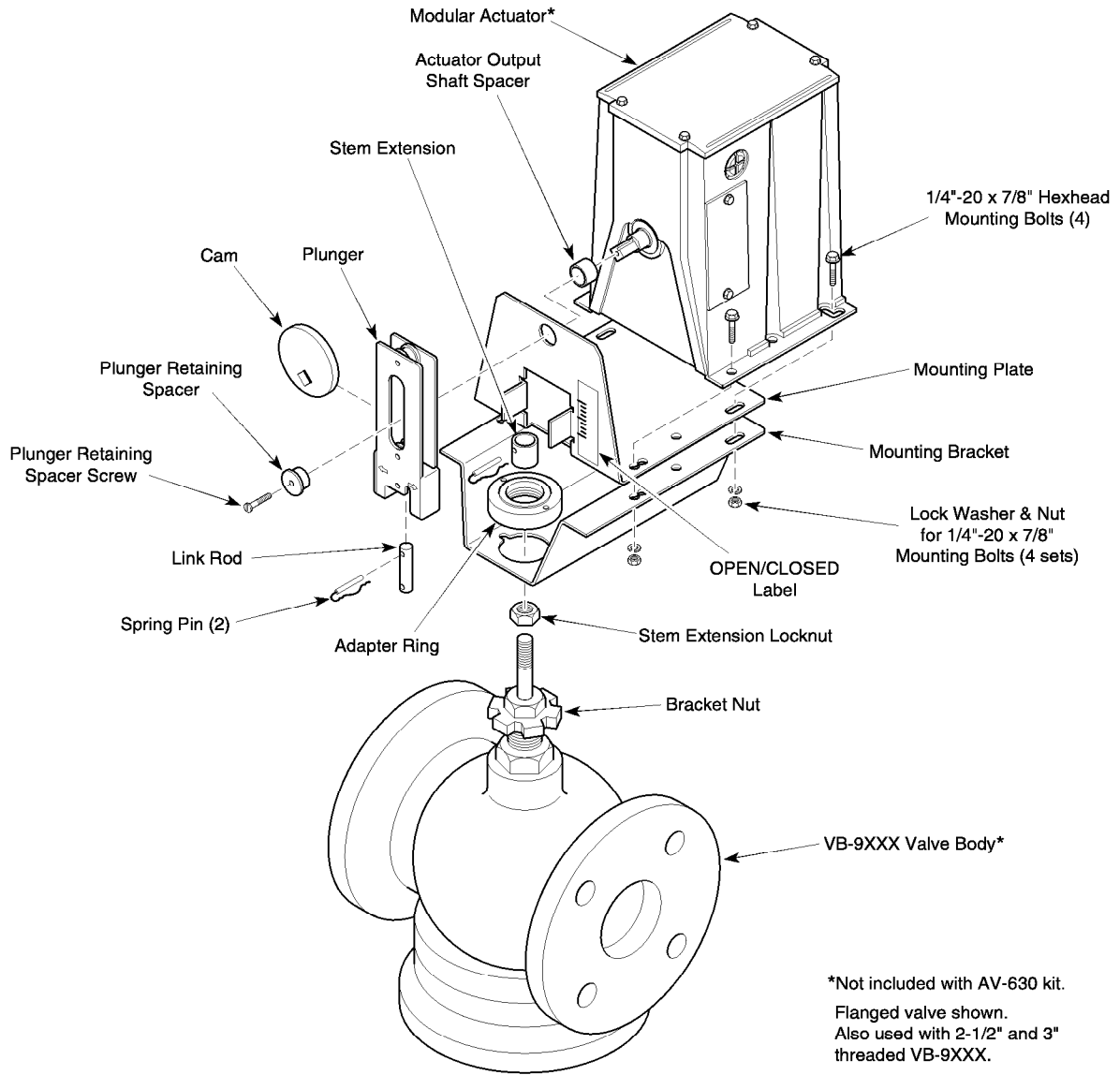

Figure-15 Assembly of AV-630 or AV-630-030 Valve Linkage with VB-9XXX Valve Body.

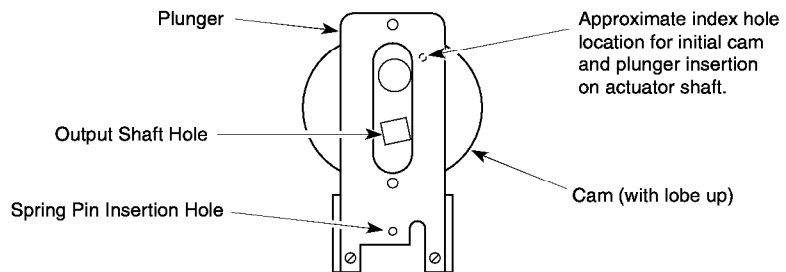

Figure-16 Initial Cam Installation Position for Valves Assembled to the "Optional, Normally Open-CW Spring Return" or "Optional" End of MM-400/500 Series Actuators.

See Table-2, Figure-15, and Figure-16.

1. Select the appropriate modular actuator, plug-in control module, valve body, and accessories.
2. Select the "Optional, Normally Open–CW Spring Return" or "Optional" end of the actuator.
3. Place the mounting plate on the mounting bracket.

**NOTE**

Make certain that the holes on the mounting bracket and mounting plate line up.

4. Place the output shaft spacer over the end of the actuator output shaft.

**NOTE**

The greater inside diameter of the spacer must rest against the retaining clip of the actuator output shaft.

5. Place the modular actuator on the mounting plate with the "Optional, Normally Open–CW Spring Return" or "Optional" end of the actuator output shaft through the hole in the mounting plate. The front slotted holes of the actuator mounting base must line up with the back end of the front slots of the mounting bracket and mounting plate.

**NOTE**

Make certain the mounting bracket and mounting plate hole alignment has not changed.

6. Insert four hexhead 1/4"-20 x 7/8" mounting bolts into the mounting base of the actuator and mounting bracket/plate assembly. Secure the actuator to the mounting bracket/plate assembly with bolts, washers, and nuts.
7. Select the cam marked 190-60.
8. With the word "POSITION" marked on the bottom of the plunger facing the installer, insert the cam into the plunger *with the cam part number facing the actuator*. The cam square shaft hole must be located on the bottom of the plunger slot and the index hole located as shown in Figure-16.

**NOTE**

The cam edge must fit in the groove between the edges of the plunger rollers.

9. Slide the cam and plunger assembly over the actuator output shaft until the cam rests against the output shaft spacer.

**NOTE**

It may be necessary to place the stem extension link rod into the stem extension before sliding the cam onto the actuator output shaft.

10. Push the plunger retaining spacer onto the actuator output shaft and secure with the #8-32 x 1/2" self-locking Allen head retaining screw.
11. Insert the stem extension 1-7/64" (28 mm) link rod into the base of the plunger and secure with a spring pin.

**NOTE**

Make certain the spring pin goes through both sides of the plunger.

12. With the valve stem pushed completely down, thread the locknut for 1/2" dia. stem completely onto the valve stem.
13. Thread the stem extension for 1/2" dia. stem completely onto the valve stem.
14. Thread the bracket nut to the bottom of the valve bonnet.

▼ **WARNING**

Any 2-1/2" to 4" VB-9XXX valve bodies date coded before 8603 must have the valve packing nut removed and replaced. Before removing the packing nut, isolate the valve body using shutoff valves or depressurize the system to zero gauge and drain the piping. The system pressure could cause packing parts to blow out with the potential of bodily injury and/or water damage.



15. Place the mounting bracket on the valve body and hold in place.
16. Thread the adapter ring on the valve bonnet.

17. Thread the bracket nut up the valve bonnet to the bottom of the mounting bracket, securing the mounting bracket to the valve body.
18. Stem extension adjustment:
  - a. Wire power and control signal to the modular actuator.
  - b. Run the actuator CCW to the end of travel.
  - c. Turn the stem extension CCW (as viewed from above) until the stem extension and stem extension link rod connecting pin holes line up.
  - d. Run the actuator CW approximately 50% of travel.
  - e. Turn the stem extension 2-1/2 turns CCW (as viewed from above) until the stem extension connecting pin hole faces the installer.
  - f. Pull the valve stem up (or run the actuator) until the connecting pin holes in the stem extension link rod and stem extension line up.
  - g. Insert the spring pin all the way through the stem extension and stem extension link rod connecting pin holes.
19. Run the actuator fully CW until the actuator stops.
20. Run the actuator fully CCW until the actuator stops.

**NOTE**

---

The index hole on the plunger cam does not normally return to its original position (as installed on the actuator output shaft). This assures proper close-off force on the valve stem. If sufficient close-off is not obtained, repeat steps 18 through 20 above, *except for step 18e*. Turn the stem extension an extra full turn CCW to provide additional compression. If sufficient close-off is still not obtained, check the valve stem and plug assembly for excessive wear. Replace the stem and plug components if required.

---

21. Tighten the stem extension locknut against the stem extension.
22. Place the 1" lift OPEN/CLOSED label on the mounting plate with the OPEN mark next to the "POSITION" arrow on the plunger (CLOSED mark toward the valve body) with the actuator in the fully CW position.
23. Replace the top cover on the actuator.
24. Checkout:
  - a. The actuator should run freely through the complete stroke.
  - b. The linkage should operate without binding.
  - c. The valve must close off tightly at the bottom of the stroke (both ends of stroke on three-way application).
25. Linkage assembly is complete.



**Mounting 2-1/2" and 3" Three-Way Diverting VB-9323 Valve Bodies to the "Optional, Normally Open-CW Spring Return" End of MM-500 Series Actuators or the "Optional" End of MM-400 Series Actuators**

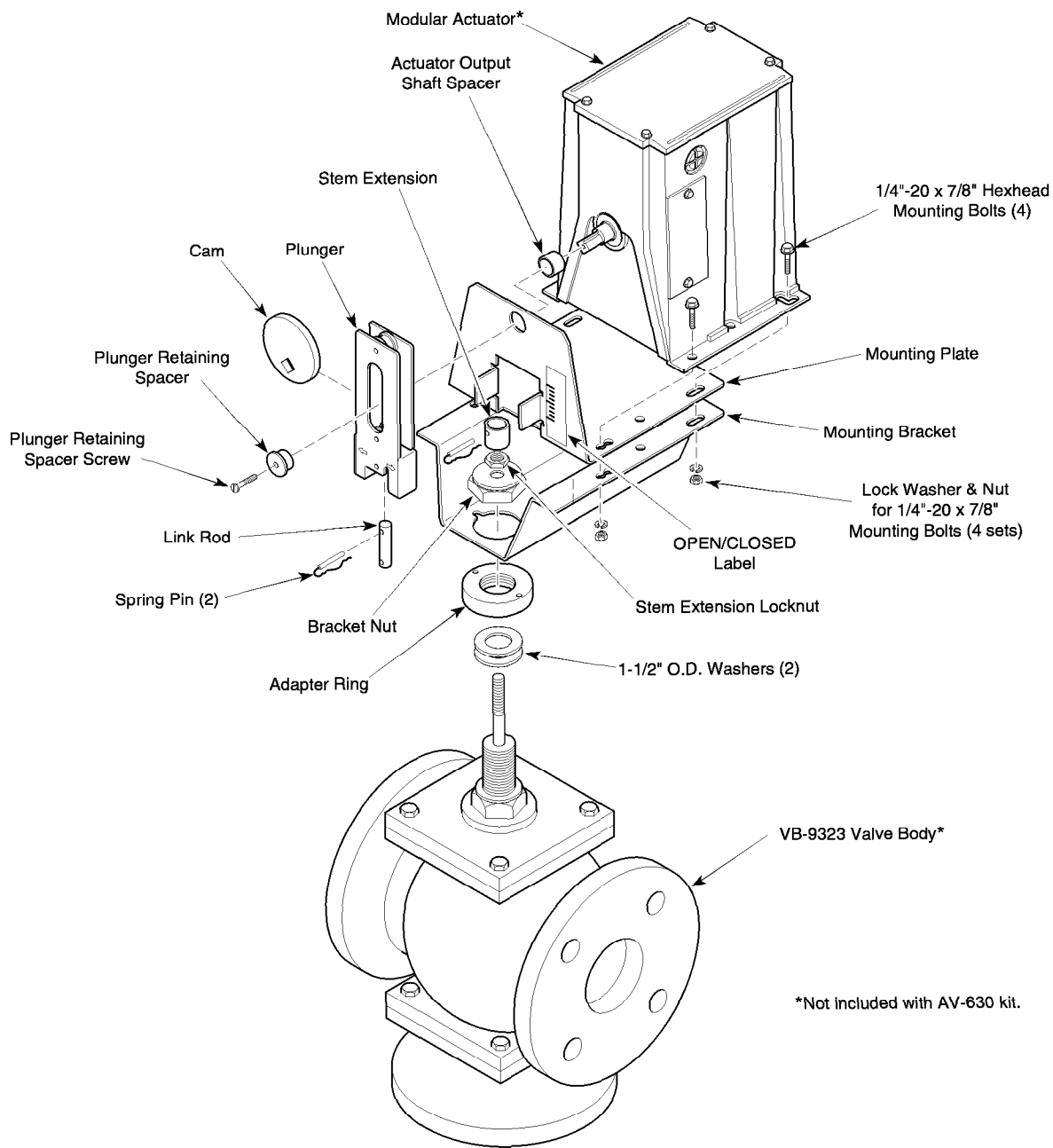

Figure-17 Assembly of AV-630 or AV-630-040 Valve Linkage with VB-9323 Valve Body.

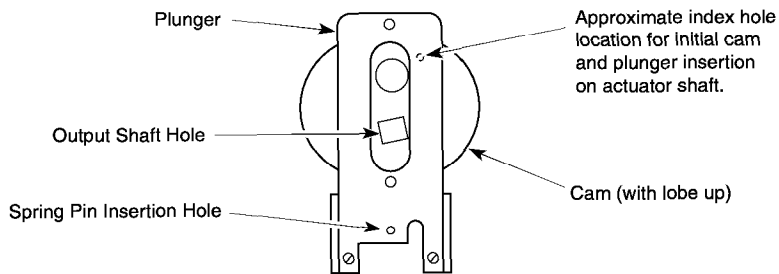

Figure-18 Initial Cam Installation Position for Valves Assembled to the "Optional, Normally Open-CW Spring Return" or "Optional" End of MM-400/500 Series Actuators.

See Table-2, Figure-17, and Figure-18.

1. Select the appropriate modular actuator, plug-in control module, valve body, and accessories.
2. Select the "Optional, Normally Open–CW Spring Return" or "Optional" end of the actuator.
3. Place the output shaft spacer over the end of the actuator output shaft.

---

**NOTE**

The greater inside diameter of the spacer must rest against the retaining clip of the actuator output shaft.

---

4. Place the modular actuator on the mounting plate with the "Optional, Normally Open–CW Spring Return" or "Optional" end of the actuator output shaft through the hole in the mounting plate. The front slotted holes of the actuator mounting base must line up with the back end of the front slots of the mounting bracket and mounting plate.

---

**NOTE**

Make certain the mounting bracket and mounting plate hole alignment has not changed.

---

5. Insert four hexhead 1/4"-20 x 7/8" mounting bolts into the mounting base of the actuator and mounting bracket/plate assembly. Secure the actuator to the mounting bracket/plate assembly with bolts, washers, and nuts.
6. Select the cam marked 190-60.
7. With the word "POSITION" marked on the bottom of the plunger facing the installer, insert the cam into the plunger *with the cam part number facing the actuator*. The cam square shaft hole must be located on the bottom of the plunger slot and the index hole located as shown in Figure-18.

---

**NOTE**

The cam edge must fit in the groove between the edges of the plunger rollers.

---

8. Slide the cam and plunger assembly over the actuator output shaft until the cam rests against the output shaft spacer.

---

**NOTE**

It may be necessary to place the stem extension link rod into the stem extension before sliding the cam onto the actuator output shaft.

---

9. Push the plunger retaining spacer onto the actuator output shaft and secure with the #8-32 x 1/2" self-locking Allen head retaining screw.
10. Insert the stem extension 13/16" (21 mm) link rod into the base of the plunger and secure with a spring pin.

---

**NOTE**

Make certain the spring pin goes through both sides of the plunger.

---

11. With the valve stem pushed completely down, thread the locknut for 3/8" dia. stem completely onto the valve stem.
12. Thread the stem extension for 3/8" dia. stem completely onto the valve stem.
13. Remove the bracket nut that is provided with the valve body.
14. Place the two 1-1/2" dia. O.D. washers on the top of the valve.
15. Place the adapter ring, with the threads down, over the washers.
16. Place the mounting bracket on the adapter ring and hold in place.
17. Thread the bracket nut, with the shoulder up, completely onto the valve bonnet, securing the mounting bracket to the valve body.
18. Place the mounting plate on the mounting bracket.

---

**NOTE**

Make certain that the holes in the mounting bracket and mounting plate line up.

---

19. Stem extension adjustment:
  - a. Wire power and control signal to the modular actuator.
  - b. Run the actuator CCW to the end of travel.
  - c. Turn the stem extension CCW (as viewed from above) until the stem extension and stem extension link rod connecting pin holes line up.
  - d. Run the actuator CW approximately 50% of travel.
  - e. Turn the stem extension 2-1/2 turns CCW (as viewed from above) until the stem extension connecting pin hole faces the installer.
  - f. Pull the valve stem up until the connecting pin holes in the stem extension link rod and stem extension line up.
  - g. Insert the spring pin all the way through the stem extension and stem extension link rod connecting pin holes.
20. Run the actuator fully CW until the actuator stops.
21. Run the actuator fully CCW until the actuator stops.

**NOTE**

---

The index hole on the plunger cam does not normally return to its original position (as installed on the actuator output shaft). This assures proper close-off force on the valve stem. If sufficient close-off is not obtained, repeat steps 19 through 21 above, *except for step 19e*. Turn the stem extension an extra full turn CCW to provide additional compression. If sufficient close-off is still not obtained, check the valve stem and plug assembly for excessive wear. Replace the stem and plug components if required.

---

22. Tighten the stem extension locknut against the stem extension.
23. Place the 3/4" lift OPEN/CLOSED label on the mounting plate with the OPEN mark next to the "POSITION" arrow on the plunger (CLOSED mark toward the valve body) with the actuator in the fully CW position.
24. Replace the top cover on the actuator.
25. Checkout:
  - a. The actuator should run freely through the complete stroke.
  - b. The linkage should operate without binding.
  - c. The valve must close off tightly at both ends of the stroke.
26. Linkage assembly is complete.

## MAINTENANCE

Regular maintenance of the total system is recommended to assure sustained, optimum performance.

## FIELD REPAIR

None. Replace an inoperative valve linkage with a functional unit.

