

**Proportional Valve and Damper Actuators
 General Instructions**

Application

The MPR-5600 series and MPR-5700 series actuators are used for electronic proportional control of dampers and valves which require a return to the normal position upon power interruption. MPR-5600 series actuators are compatible with controllers generating 4 to 20 mA input signals, and MPR-5700 series actuators are compatible with 135 Ω slidewire controllers (Series 90).

Features

- Spring return
- 24 Vac, 120 Vac, and 240 Vac models are available
- Available in damper models or base models that require damper or valve linkage
- Die cast lower housing with 1/2" conduit opening and painted steel upper housing
- Hydraulic actuator with oil-immersed motor, transducer, and pump

MPR-5600 Series

- Proportional actuators controlled by a variable mAdc input signal
- Fixed 4 to 20 Adc operating range
- 82.5 Ω input impedance
- Adjustable actuator startpoint

MPR-5700 Series

- Proportional actuators controlled by a controller with a 135 Ω slidewire output

Applicable Literature

- Siebe Environmental Controls Cross-Reference Guide, F-23638
- Siebe Environmental Controls Reference Manual, F-21683
- Siebe Environmental Controls Application Manual, F-21335
- Siebe Environmental Controls First Edition Catalog, F-25683

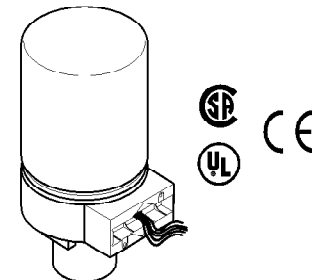

**MPR-561X Series
 Valve Actuator**

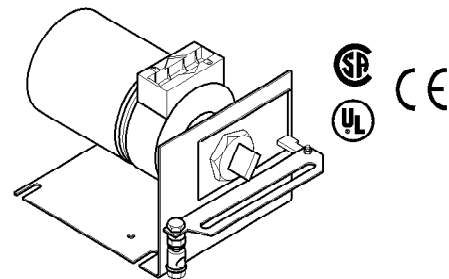

**MPR-5X3X Series
 Damper Actuator**

- Engineering Bulletin EN-110, Damper Actuator Sizing, F-15260
- AV-600 Hydraulic Actuator Valve Linkage Kit, F-26279
- AV-601 Linkage Extension Set for AV-600 Valve Linkage Kit, F-26280
- VB-7000 Valve Selection Guide, F-26094
- VB-7000 Cross Reference Guide, F-26175
- Material Safety Data Sheet MSDS-3 (Until Feb. 1989)
- Material Safety Data Sheet MSDS-12 (Currently)

SPECIFICATIONS

Transducer Inputs

Control Circuit:

MPR-561X and -563X Series, Two-wire.

MPR-571X and -573X Series, Three-wire.

Input Impedance: 82.5 Ω for 4 to 20 mA input.

Power Input: Refer to Table-1 and Table-2.

Connections: Color-coded 4' (1.2 m) leads.

Transducer Outputs

Electrical:

Position Signals, Internal feedback circuitry provides positive positioning of the damper in relation to the controller signal.

Startpoint Adjustment, Adjustable potentiometer provides manual adjustment of the actuator startpoint.

Mechanical:

Stroke,

Damper Approximately 2" (51 mm) from fully retracted to fully extended (includes AM-601 linkage).

Valve Approximately 9/16" (14.3 mm) from fully retracted to fully extended.

Nominal Damper Area, Actuator sizing should be done in accordance with damper manufacturer's specifications.

Output Torque Rating, The proportional output torque rating of 15 lb-in. (1.7 N-m) is available throughout the entire stroke and is based on the lowest force available under normal operation, the spring return stroke, or at minimum (-10%) supply voltage.

Environment

Ambient Temperature Limits:

Shipping & Storage, -40 to 140° F (-40 to 60° C).

Operating,

Damper -20 to 140° F (-29 to 60° C).

Valve Refer to Table-3.

Humidity: 5 to 95% RH, non-condensing.

Location: NEMA Type 1, indoor only.

Agency Listings:

UL 873: Underwriters Laboratories (File # E9429 Category Temperature-Indicating and Regulating Equipment).

CSA: Certified for use in Canada by Underwriters Laboratories. Canadian Standard C22.2 No. 24-93.

European Community: EMC Directive (89/336/EEC). Low Voltage Directive (72/23/EEC).

Table-1 Model Chart for Valve (Basic) Actuators.

Part Number ^a	Actuator Power Input				Timing in Seconds @ 72° F (22° C)			Required Linkages		Input Signal
	AC Voltage +10/-15%	Hz	VA	Watts	No Load Stroke		Retract on Power Loss	Valve Applications	Damper Applications ^b	
					Extend	Retract				
MPR-5610	120	50/60	18	10	60	30	15	AV-600 AV-601 ^c	AM-601	Compatible with 4 to 20 mA
MPR-5611	240									
MPR-5613	24									
MPR-5710 ^d	120									Compatible with 135 Ω Slidewire (Series 90)
MPR-5711 ^d	240									
MPR-5713	24									

^aThese MPR-5X1X series valve actuators are compatible with VB-7XXX 1/2" to 2" valve bodies.

^bThe MPR-5X1X series actuators are basic models which may be equipped for damper applications with the installation of an AM-601 linkage.

^cMay be required for steam and hot water. Refer to Table-3.

^dThese actuators are obsolete. They are listed here for reference only.

Table-2 Model Chart for Damper Actuators.

Part Number ^a	Actuator Power Input				Timing in Seconds @ 72° F (22° C)			Input Signal	
	AC Voltage +10/-15%	Hz	VA	Watts	No Load Stroke		Retract on Power Loss		
					Extend	Retract			
MPR-5630	120	50	60	18	10	60	30	15	Compatible with 4 to 20 mA
MPR-5633	24								
MPR-5730 ^b	120								Compatible with 135 Ω Slidewire (Series 90)
MPR-5733 ^b	24								

^aDamper models (MPR-5X3X) are provided with factory-installed damper linkages. Only base models (MPR-5X1X) require separately-ordered linkages.

^bThese actuators are obsolete. They are listed here for reference only.

Table-3 Restrictions on Maximum Ambient Temperature for Valve Actuators.

Maximum Temperature of Media in the Valve Body (Check Rating of the Valve) °F (°C)	Maximum Ambient Temperature of MPR-563X and -573X Series	
	AV-600 (Only) °F (°C)	AV-600 and AV-601 °F (°C)
366 (186)	Do Not Use	88 (31) ^b
340 (171)		93 (34)
281 (138)		103 (39) ^a
181 (83)		120 (48) ^a
80 (26)	140 (60) ^a	140 (60) ^a

^aMaximum ambient temperature of the actuator must never exceed 140° F (60° C).

^bMinimum allowable ambient temperature of the actuators is -20° F (-29° C).

ACCESSORIES

Common

11-1612 1/2" conduit bushing

Damper Linkages

AM-111 Crank arm for 5/16" diameter damper shaft
 AM-112 Crank arm for 3/8" diameter damper shaft
 AM-113 Crank arm for 1/2" diameter damper shaft
 AM-115 Crank arm for 7/16" diameter damper shaft
 AM-122 Linkage connector straight type
 AM-123 Damper clip
 AM-125 5/16" diameter x 20" damper rod
 AM-125-048 5/16" diameter x 48" damper rod
 AM-132 Ball joint connector
 AM-161-3 Damper linkage kit
 AM-601 Device includes mounting bracket, damper linkage with spring, and AM-122 straight connector. Required to modify (MPR-5X1X series) valve actuators into 2" (51 mm) stroke damper actuators.

AM-602 Spacer
Valve Linkages and Valves

AV-600 Valve linkage 1/2" to 1-1/4" (obsolete VB-9XXX)
 AV-601 Valve linkage extension for hot water and steam applications; use with AV-600 & AV-7600
 AV-7600 Valves linkage 1/2" to 2" to be used with VB-7XXX
 VB-7XXX 1/2" to 2" valve bodies
 VB-9XXX 1/2" to 1-1/4" valve bodies (obsolete)

TOOLS (factory-available)

TOOL-19 Spring compression tool for AV-600
 TOOL-37 1-5/8" open-ended wrench
 TOOL-209 135 Ω and 0 to 7 mA manual positioner

TYPICAL APPLICATIONS (wiring diagrams)

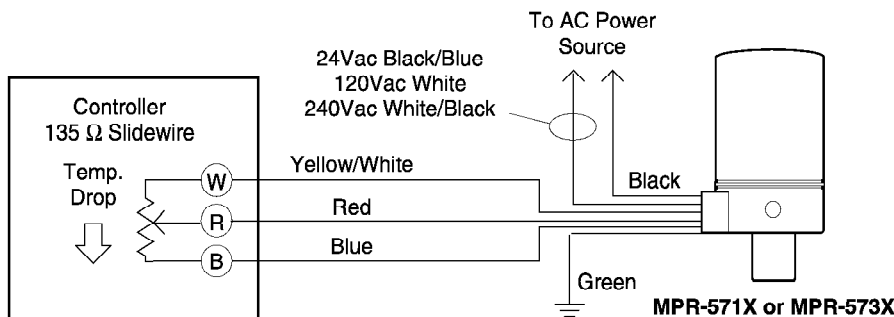

Sequence of operation: As the temperature decreases at the controller, R moves toward B and the actuator shaft extends. On power loss to the actuator, the shaft retracts.

Notes:

1. The 135 Ω controller is supplied by others.
2. The controller has setpoint and throttling range (proportional band) adjustments.

Figure-1 Wiring Diagram - Decrease in Temperature Causes Actuator Shaft to Extend.

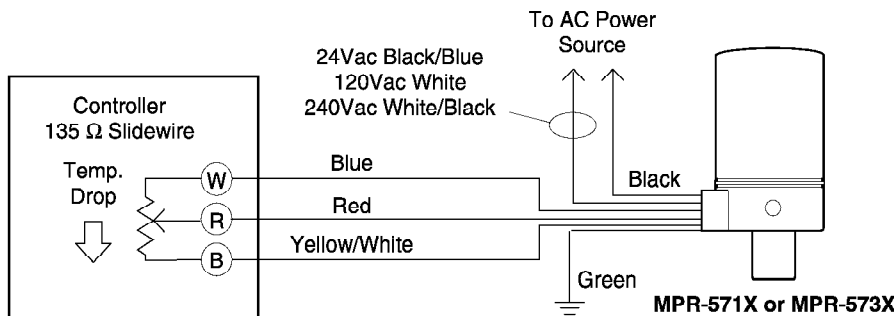

Sequence of operation: As the temperature decreases at the controller, R moves toward B and the actuator shaft retracts. On power loss to the actuator, the shaft retracts.

Notes:

1. The 135 Ω controller is supplied by others.
2. The controller has setpoint and throttling range (proportional band) adjustments.

Figure-2 Wiring Diagram - Decrease in Temperature Causes Actuator Shaft to Retract.

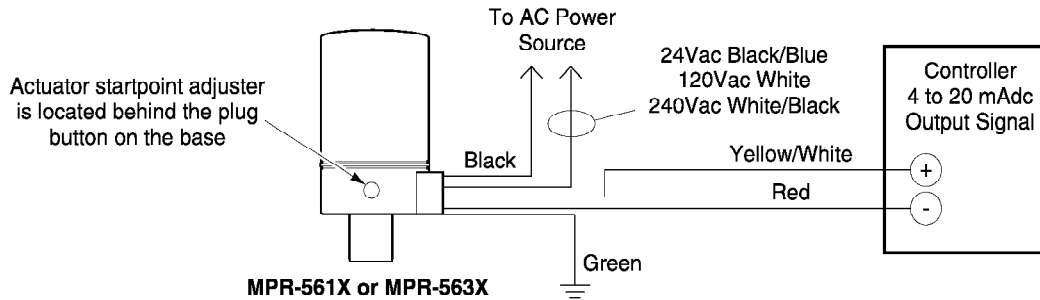

Notes:

1. The 4 to 20 mAdc controller is supplied by others.
2. The controller has setpoint and throttling range (proportional band) adjustments. The controller may also incorporate I (integral) and D (differential) functions.
3. To expose the startpoint adjuster, remove the plug button from the base of the actuator by prying it off with a screwdriver. With a 4 mA controller input signal present, use a small, single-slotted screwdriver to adjust the actuator startpoint potentiometer so that the actuator shaft just begins to extend.
4. The output can be either direct-acting or reverse-acting:
 Direct-Acting (DA) Output: An increase in the measured media causes the controller output (4 to 20 mA signal) to increase.
 Reverse-Acting (RA) Output: An increase in the measured media causes the controller output (4 to 20 mA signal) to decrease.

Sequence Of Operation:

An increase in the 4 to 20 mAdc signal causes the MPR-561X or MPR-563X actuator shaft to extend. On power loss to the actuator, the shaft retracts.

Figure-3 Wiring Diagram - 4 to 20 mAdc Controllers.

INSTALLATION

Inspection

Inspect the package for damage. If damaged, notify the appropriate carrier immediately. If undamaged, open the package and inspect the device for obvious damage. Return damaged products.

Requirements

- Job wiring diagrams
- Tools (not provided):
 - Digital Volt-ohm Meter (DVM)
 - Appropriate drill and drill bit for mounting screws
 - TOOL-19, Spring compression tool for AV-600
 - TOOL-37, 1-5/8" open-ended wrench
 - TOOL-209, 135 Ω and 0 to 7 mA manual positioner
 - Two 3/8" wrenches
- Training: Installer must be a qualified, experienced technician

Warning: Disconnect power supply before installation to prevent electrical shock and equipment damage.



Caution:

- Use electrostatic discharge precautions (e.g., use of wrist straps) during installation and wiring to prevent equipment damage.
 - Make all connections in accordance with the wiring diagram and in accordance with national and local electrical codes. *Use copper conductors only.*
 - Do not exceed the ratings of the device(s).
 - Do not apply power to the unit unless the damper linkage and/or the valve assembly have been installed.
 - Avoid locations where excessive moisture, corrosive fumes, or vibration is present.
 - Do not install insulation on any part of the actuator.
-

Mounting

Caution: Do not twist or exert any force on the actuator housing during installation. Either turn the base by hand or, if necessary, use a 1-5/8" open-ended wrench (TOOL-37) on the flats provided on the actuator base or the valve body mounting nut. Refer to Figure-4 .

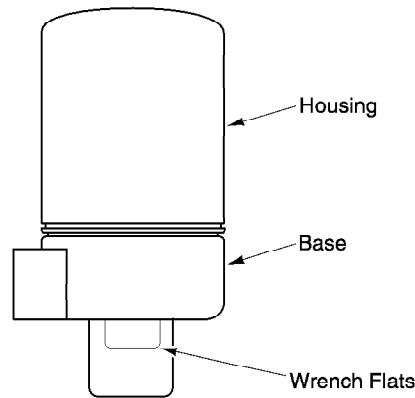

Figure-4 Housing and Base Location.

Dampers

The actuator is not position sensitive. It can be mounted in any position in an NEMA Type 1 location.

Valves

Allow 3" (76 mm) of clearance above the actuator valve assembly for the removal and reattachment of the actuator to the installed valve.

1. Install all two-way valves so that they close against the flow. An arrow on the valve body or tag indicates proper flow direction.
2. Always install three-way mixing valves with two inlets and one outlet.
3. Always install three-way diverting valves with one inlet and two outlets.
4. For steam applications only, mount the actuator above the valve body at 45° from vertical.
5. Actuators can be mounted in any upright position above the centerline of the valve body.

Wiring Requirements

Control Leads

The control leads may be connected to a Class 2 circuit if routed separately from Class 1 circuit wiring. Refer to Figure-9 .

Caution:

- Use either 18 gage, two- or three-conductor twisted, shielded wire when it becomes necessary to install the control leads in the same conduit with power wiring or when high RFI/EMI generating devices are near.
 - Do not connect the shield to earth ground or any other leads.
-

135 Ω Slidewire Controller: Use 18 gage, three-conductor, twisted leads (Siebe Part Number W-103 or equivalent) for runs of up to 500 ft. (152 m) between the 135 Ω slidewire controller and the actuator. Use larger-gage wires for longer runs.

4 to 20 mAdc Controller: Use 18 gage, two-conductor, twisted leads (Siebe Part Number W-102 or equivalent) for runs of up to 500 ft. (152 m) between the 4 to 20 mAdc controller and the actuator. Use larger-gage wires for longer runs.

Power Leads

The low voltage (24 Vac) actuators may be connected to a Class 2 circuit.

Line voltage (120 Vac and 240 Vac) power leads must be connected to a Class 1 circuit and routed separately from Class 2 circuit wiring. Refer to Figure-9 .

Refer to Table-4 for the maximum length of run for the power leads, for the given wire size(s).

To determine the allowable maximum power lead run when wiring multiple actuators, divide the maximum run shown in Table-4 by the number of actuators on the run. Refer to Figure-5 for further details.

Table-4 Power Wiring Data.

Actuator Voltage Vac	Actuator Model Number	Power Lead Colors*	Wire Size GA	Max. Two-Wire Run ft. (m)
24	MPR-5613	Black/Blue & Black	14	300 (91.5)
	MPR-5713			
	MPR-5633		12	
	MPR-5733			
120	MPR-5610	White & Black	14	3,500 (1,067)
	MPR-5710			
	MPR-5630			
	MPR-5730			
240	MPR-5611	White/Black & Black	14	6,000 (1,829)
	MPR-5711			

*Green grounding wire is provided. Length is 4 ft. (1.2 m).

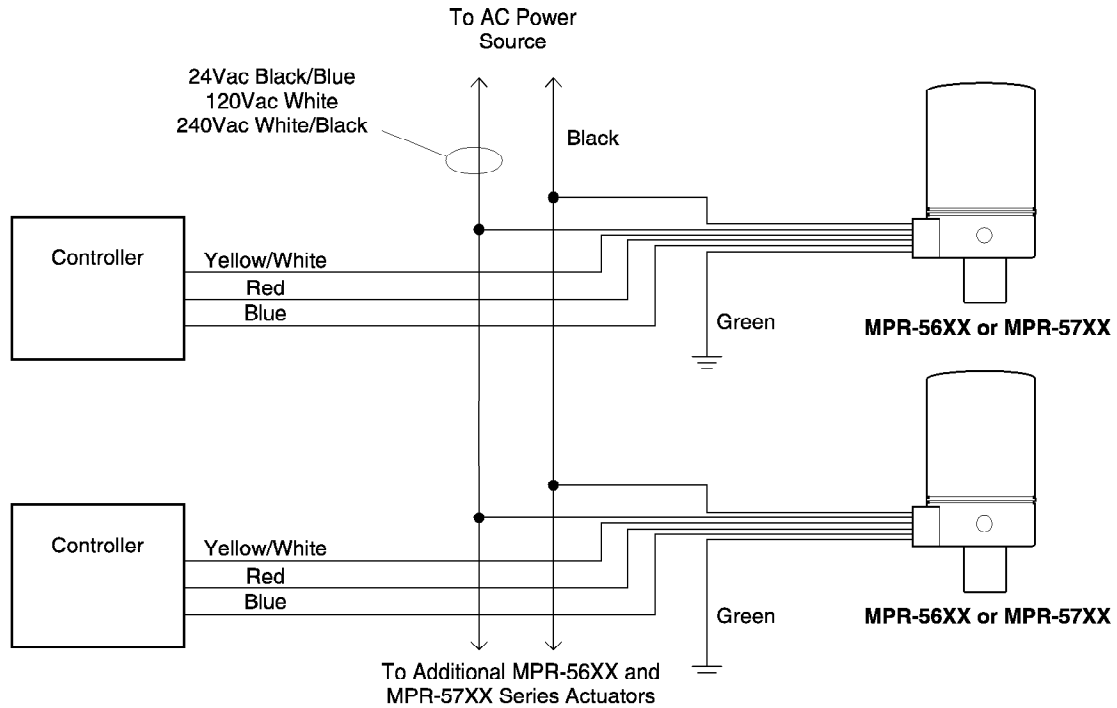

Figure-5 Wiring of Multiple MPR-56XX and MPR-57XX Series Actuators to a Single Power Source.

Wiring Connections

General

Make connections as required. Refer to the following sections:

- Wire Lead Connections (No Conduit)
- Install 3/8" reduced (thin wall) flexible conduit onto either side of actuator
- Install 3/8" reduced (thin wall) flexible conduit directly onto actuator
- Install conduit box onto actuator

Wire Lead Connections (No Conduit)

Make connections as required. Refer to Figure-1 through Figure-3 to determine your particular application. Refer to Table-5 to determine the damper position versus the input signal. Refer to Figure-6 for a view of the actuator.

Note: The cover plate and screw supplied with the actuator are not required with this method.

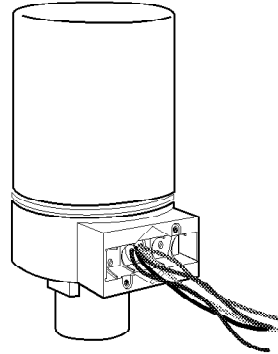

Figure-6 Connection of Wire Leads (No Conduit).

Table-5 Damper Position Versus Input Signal.

Damper Normal Position	MPR-573X Series 135 Ω Slidewire (Series 90) Input Signal				MPR-563X Series 4 to 20 mA Input Signal	
	Figure-1		Figure-2		Figure-3	
	Decrease In "R" to "B" Resistance	Decrease In "R" to "W" Resistance	Decrease In "R" to "B" Resistance	Decrease In "R" to "W" Resistance	Decrease In mA Signal	Increase In mA Signal
Normally Open	Closes Damper	Opens Damper	Opens Damper	Closes Damper	Opens Damper	Closes Damper
Normally Closed	Opens Damper	Closes Damper	Closes Damper	Opens Damper	Closes Damper	Opens Damper

Installing 3/8" Reduced (thin) Wall Flexible Conduit onto One or Both Sides of Actuator

Flexible conduit may be installed onto one or both sides of the actuator (refer to Figure-8 and Figure-9). Install each conduit as follows:

1. Determine the side of the actuator to which the flexible conduit is to be attached.
2. Remove the knockout, using channel lock pliers, on the selected side of the actuator. Refer to Figure-7 .
3. Make the required connections. Refer to Figure-1 , Figure-2 , and Figure-3 to determine your particular application. Refer to Table-5 to determine the damper position versus the input signal.

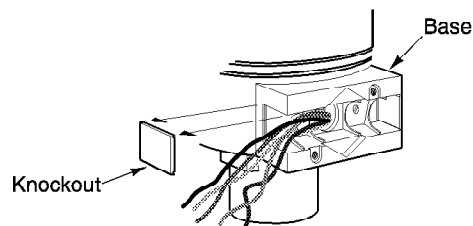

Figure-7 Removal of Knockout on Actuator Base.

4. Slip the conduit onto the base, over the ribs. Refer to Figure-8 and Figure-9 .

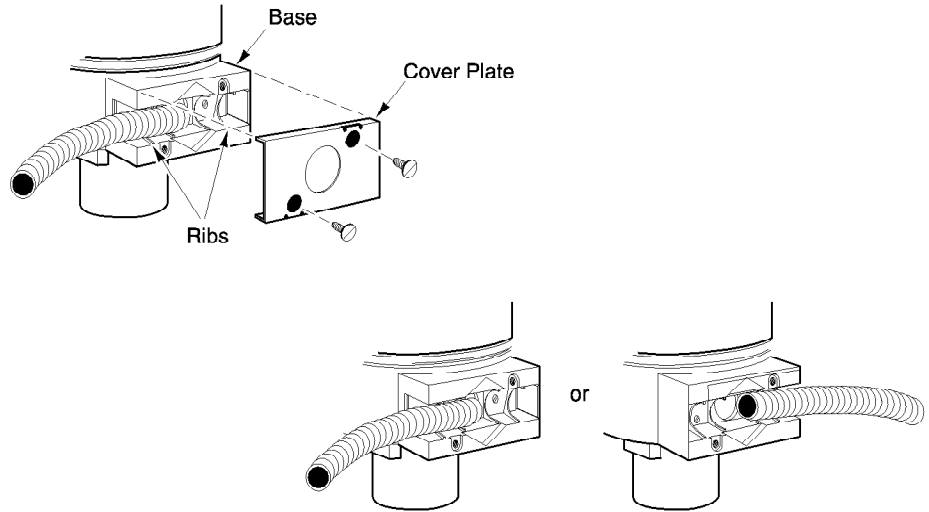

Figure-8 Flexible Conduit Installation to Either Side of Actuator.

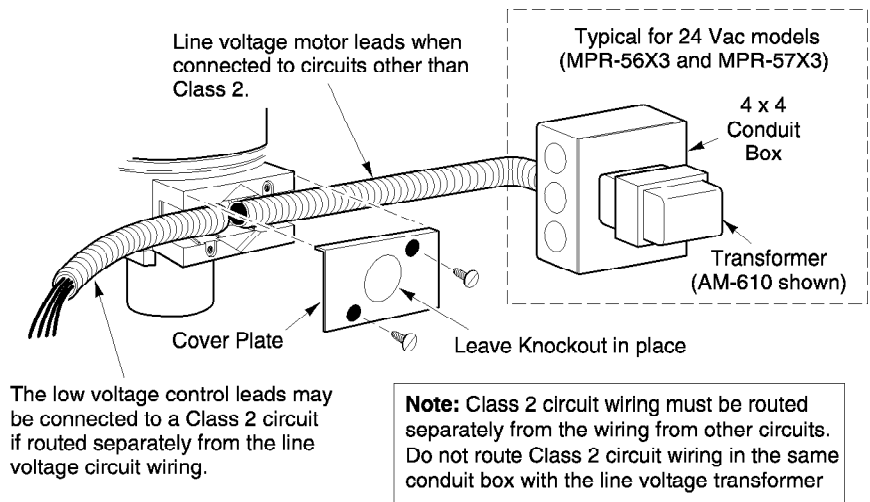

Figure-9 MPR-5600 and MPR-5700 Series Wiring with Separation for Class 2 and Line Voltage Circuits.

5. Install the cover plate with two screws. The cover plate and two screws are supplied with the actuator.
6. If flexible conduit is to be installed on both sides of the actuator, repeat the preceding steps to install the second conduit.

Installing 3/8" Reduced (thin) Wall Flexible Conduit Directly onto Actuator

1. Remove the knockout from the cover plate supplied with the actuator. Refer to Figure-10 .

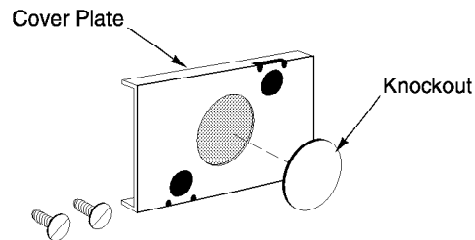

Figure-10 Cover Plate Knockout Removal.

- Slip the leads through a standard 1/2" conduit bushing (not supplied) and the knockout hole in the cover plate. Refer to Figure-11 and Figure-12 .

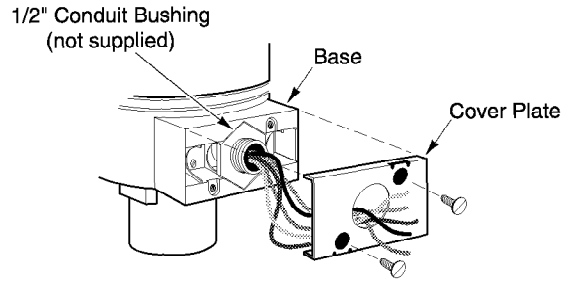

Figure-11 Conduit Bushing and Cover Plate Installation.

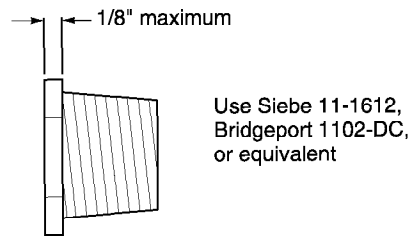

Figure-12 1/2" Conduit Bushing.

- Nest the conduit bushing in the base.
- Install the cover plate, using the two screws provided.
- Make the required connections. Refer to Figure-1 through Figure-3 to determine your particular application. Refer to Table-5 to determine the damper position versus the input signal.
- Attach the flexible conduit to the conduit bushing, as required.

Installing Conduit Box onto Actuator

- Remove the knockout from the cover plate supplied with the actuator. Refer to Figure-10 .
- Slip the leads through a standard 1/2" conduit bushing (not supplied) and the knockout hole in the cover plate. Refer to Figure-11 and Figure-12 .
- Nest the conduit bushing in the base.
- Install the cover plate, using the two screws provided.
- Attach the conduit box to the threaded adaptor.
- Make the required connections. Refer to Figure-1 through Figure-3 to determine your particular application. Refer to Table-5 to determine the damper position versus the input signal.
- Install the rigid conduit, the flexible conduit, etc. to the conduit box as required. Refer to Figure-13 .

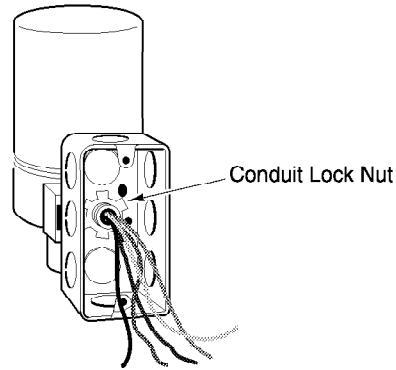

Figure-13 Attachment of Conduit Box to Threaded Adaptor.

Note: As shown in Figure-11 , the hole in the cover plate of the actuator conduit housing is sized to accept both British standard M20 (20 mm) conduit connectors and 20 mm-to-PG16 adaptors for use with DIN PG16 connectors. (Follow the steps for installing the conduit box to the actuator.)

Linkage Assembly

Damper

Note: Each actuator in the MPR-5X3X series is provided with a factory-installed damper linkage. No separately-ordered linkage is required.

Caution:

- Do not twist or exert any force on the actuator housing during installation. Either turn the base by hand or, if necessary, use a 1-5/8" open-ended wrench (TOOL-37) on the flats provided on the actuator base, or on the valve body mounting nut. (Refer to Figure-4)

- Determine the best mounting position for the actuator as follows:
 - Determine, from the system requirements, if the damper should spring-return to the open position (Figure-14) or closed position (Figure-15) whenever power is lost to the actuator. An actuator is normally linked so as to retract (spring-return) to the damper's fully open position (heat position).

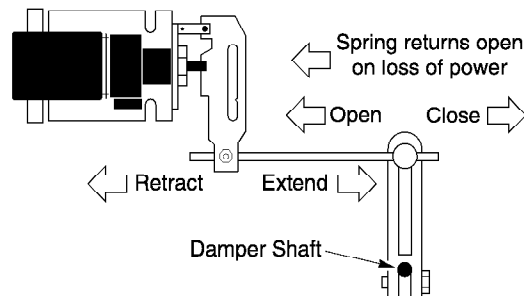

Figure-14 Dampers Open When Actuator Retracts (Spring>Returns Open on Power Loss).

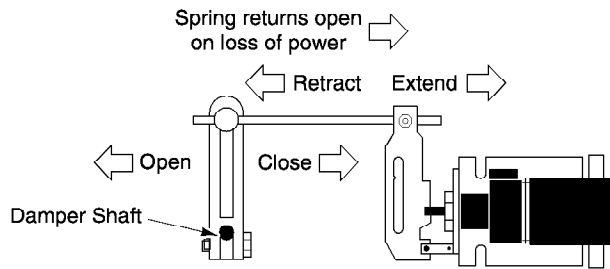

Figure-15 Dampers Open When Actuator Extends (Spring-Returns Closed on Power Loss).

- b. Be sure to allow adequate working space around the actuator mounting location to mount the actuator, link it to the damper, and wire it into the system (refer to Figure-21).
- c. If possible, select a mounting position such that, at mid-stroke, the actuator crank arm and the damper crank arm on the drive shaft are each at a 90° angle to the damper rod (refer to Figure-16). This is the recommended mounting position. It may be necessary to swivel the actuator linkage to arrive at this mounting location.

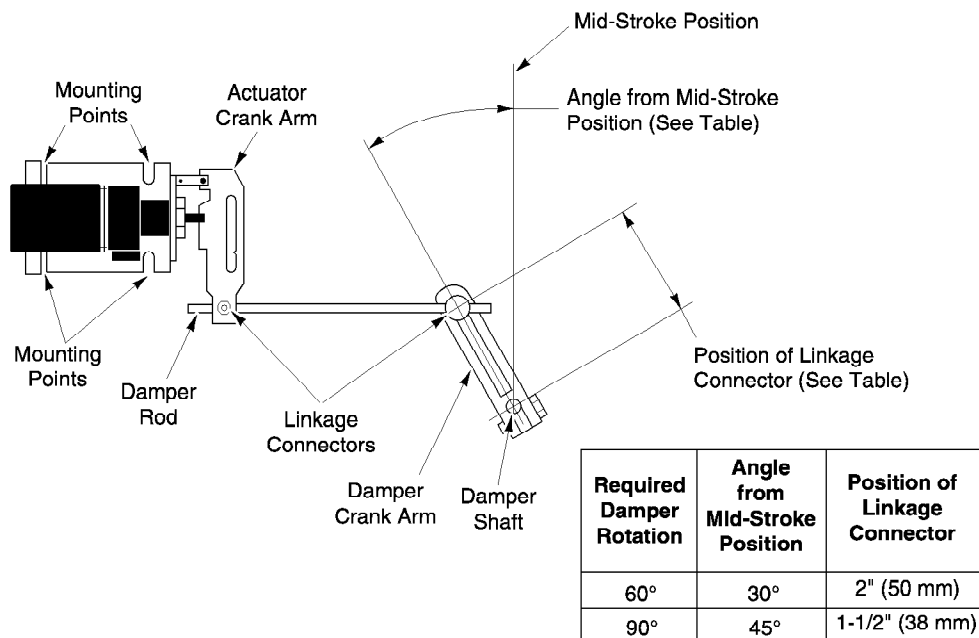

Figure-16 Recommended Actuator/Damper Mounting.

- d. Consider the damper rod length when positioning the actuator in relation to the damper. A damper rod that is too long is not rigid enough to provide good control, while a damper rod that is too short makes adjustment difficult.
2. Position the actuator on the duct and mark the location of the mounting holes, using the actuator mounting bracket as a template (refer to Figure-21).
3. Drill or punch the mounting holes in the duct for the appropriate 1/4" diameter screws or bolts. The actuator must be mounted firmly enough to prevent excessive actuator movement under normal damper loading. If there is excessive actuator movement, the damper may not fully open or close.
4. Mount a ball joint connector in the slot on the damper crank arm. To achieve 90° of damper rotation, position the connector 1-1/2" (38 mm) from the centerline of the shaft hole on the crank arm. For 60° of damper rotation, position the connector 2" (50 mm) from the shaft hole centerline. Typically, 60° to 70° of rotation (maximum is 90°) is sufficient to permit almost maximum air flow through the dampers. Refer to Figure-16 .

5. Rotate the damper to its open position. Install and secure the damper crank arm (with ball joint connector) to the damper shaft, positioning the crank arm as follows (refer to Figure-16):
 - a. To achieve 60° of damper rotation, position the crank arm so that it is pointed towards the actuator at 30° from its mid-stroke position.
 - b. To achieve 90° of damper rotation, position the crank arm so that it is pointed towards the actuator at 45° from its mid-stroke position.
6. Install the damper rod by sliding one end through the ball joint connector mounted on the damper crank arm, and the other end through the straight connector on the actuator crank arm. Tighten the nut on the actuator crank arm's straight connector. Cut off any excess length of damper rod.
7. For normally open dampers, tighten the nut on the ball joint connector on the damper crank arm. To ensure that the damper closes completely, make adjustments so that the actuator is 1/16" (1.6 mm) from the extended end of stroke when the damper closes. Verify and, if necessary, make final adjustments during system checkout.
8. For normally closed dampers, rotate the damper crank arm until the damper is closed. While holding the damper closed, tighten the nut on the ball joint connector on the damper crank arm. To ensure that the damper closes completely, make adjustments so that the actuator is 1/16" (1.6 mm) from the retracted end of stroke when the damper closes.

Final adjustment of the actuator and damper must be performed when the system is powered and functioning. Refer to the CHECKOUT section to ensure that the damper is linked correctly.

Valve

For valve assembly details refer to **AV-600 Hydraulic Actuator Valve Linkage Kit, F-26279** or **AV-601 Linkage Extension Set for AV-600 Valve Linkage Kit, F-26280**. Refer to Figure-22 for external dimensions of the valve actuator.

CHECKOUT

After the entire system has been installed and the actuator has been powered up, perform the following checks for proper system operation.

Caution: Never power the actuator without a spring return linkage attached.

Positioning with Controller

If the sensed media is within the controller's setpoint range, the actuator can be positioned by adjusting the controller setpoint up and down. Check for correct operation of the actuator (valve or damper) while the actuator is being stroked.

Go, No-Go Test (MPR-57XX Series Only)

1. Apply power to the actuator.
2. Disconnect the actuator's control leads from the controller.
3. Make the actuator shaft extend fully by shorting the red lead to the blue lead.
4. Make the actuator shaft retract fully by shorting the red lead to the yellow/white lead.
5. Check for proper operation of the valve or damper as the actuator is operated.
6. Reconnect the actuator wires to the controller.
7. Remove power from the actuator.

Manual Positioning (MPR-57XX Series Only)

1. Apply power to the actuator.
2. Disconnect the actuator's control leads from the controller.
3. Attach the slidewire leads from the calibration box (TOOL-209) to the same-color leads on the actuator.
4. Manually position the actuator by turning the knob of the calibration box (TOOL-209). Turning the knob in the clockwise direction retracts the actuator shaft. Turning the knob in the counterclockwise direction extends the actuator shaft.
5. Check for proper operation of the valve or damper as the actuator is operated.

6. Reconnect the actuator wires to the controller.
7. Remove power from the actuator.

THEORY OF OPERATION

Refer to Figure-17 . The permanently sealed, oil-filled case contains a movable hydraulic piston assembly and an electric pump/motor for the hydraulic system. The electric pump/motor is powered by the input supply voltage and runs continuously, generating a fluid pressure which is transmitted to the top of the piston. This fluid pressure creates a hydraulic force which drives the piston downward. Opposing the hydraulic force is the spring of the valve or damper linkage. When the hydraulic force becomes great enough to overcome the opposing spring force, the piston translates downward, extending the output shaft.

The pump/motor contains a transformer winding which provides power to the Vdc power supply. The power supply, in turn, provides power to the transducer assembly. To proportionally position the shaft, first the control signal (135 Ω slidewire or the 4 to 20 mA) input is compared to the shaft position feedback signal, through the actuator controller circuit. Then, the actuator controller circuit emits an output signal which positions the flapper in the transducer. The flapper opens or closes further to decrease or increase the hydraulic pressure above the piston, resulting in an upward or downward movement at the shaft.

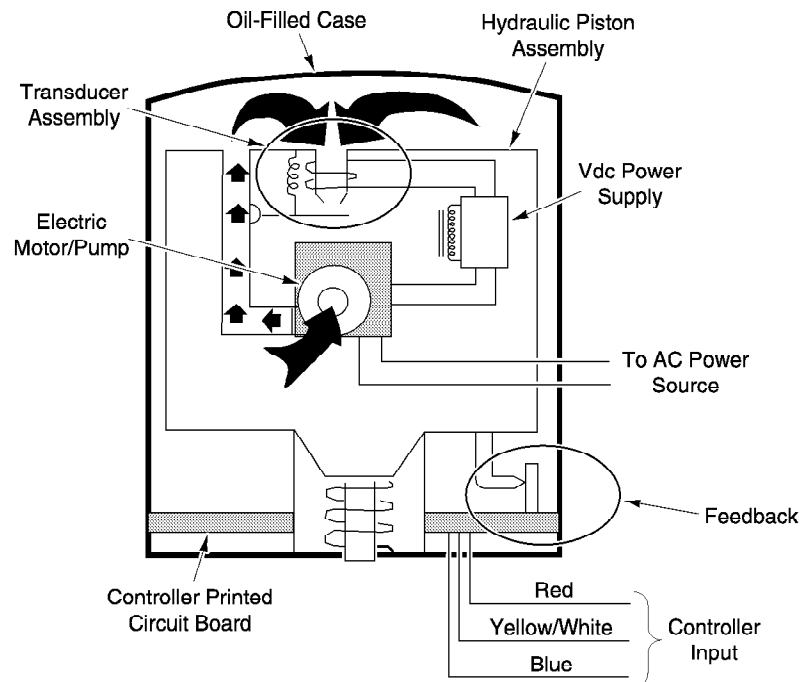

Figure-17 MPR-56XX and MPR-57XX Series Actuators.

REPLACEMENT PARTS

The installation of replacement actuators, in place of the obsolete series of MPR-56XX and MPR-57XX actuators (refer to Figure-18), may require additional items. These replacement items are required for the following reasons:

1. The AM-601 damper linkage is used to convert base actuators to damper actuators when damper models are not available.
2. The AM-602 spacer is used when current actuators are installed on old linkages (refer to Figure-19 and Figure-20).
3. The AE-249 transformer (208 Vac to 120 Vac) is used when replacing 208 Vac actuators (MPR-5XX2) with 120 Vac actuators (MPR-5XX0).

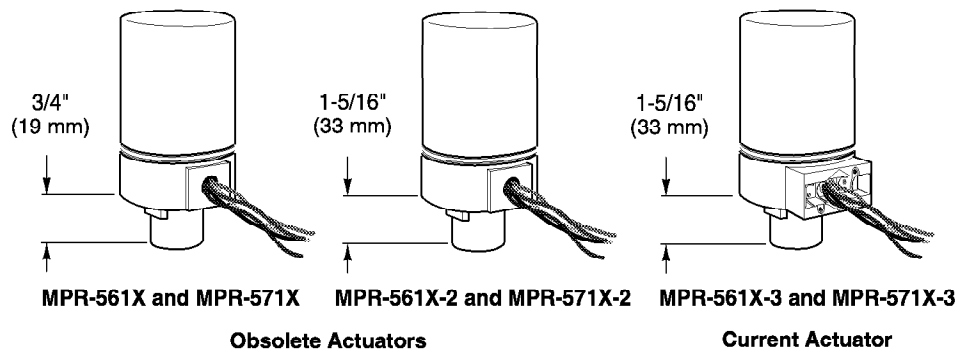

Figure-18 Current and Obsolete Actuators

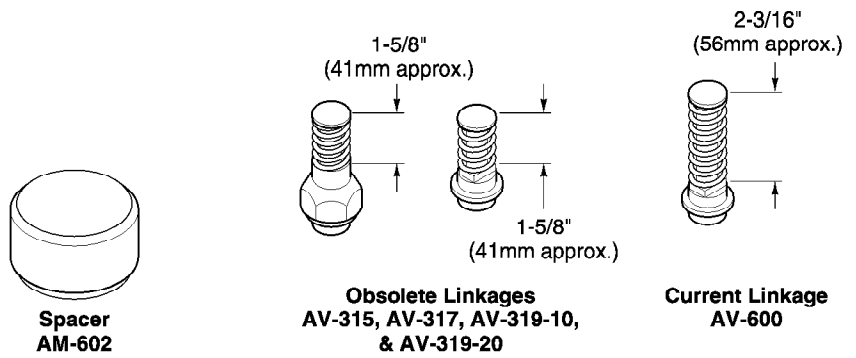

Figure-19 Spacer and Current and Obsolete Valve Linkages.

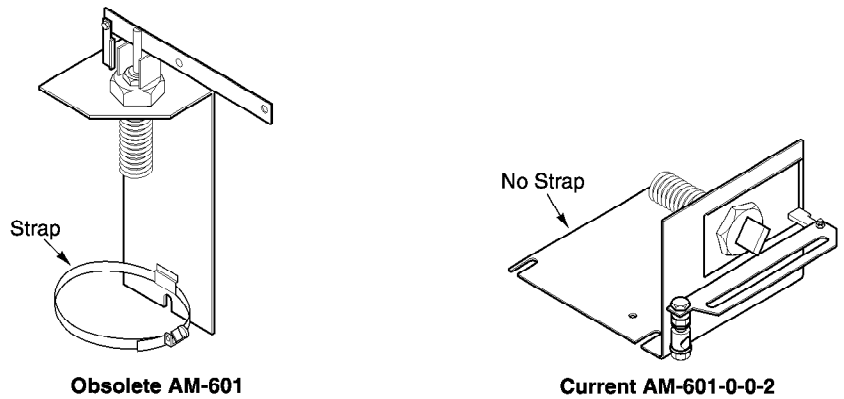

Figure-20 Current and Obsolete Damper Linkages.

MAINTENANCE

The actuator is sealed in oil and requires no maintenance.

Regular maintenance of the total system is recommended to assure sustained, optimum performance.

TROUBLESHOOTING

Use the following steps to locate malfunctions:

1. Check the controller and determine that it is operating to the manufacturer's specifications.
2. The actuator motor should run continually. If it does not run, check the supply voltage and the actuator wiring.
3. Verify actuator operation, using the Go, No-Go Test. If the actuator does not function, replace it with a functional unit.

FIELD REPAIR

None. Replace an inoperative actuator with a functional unit.

DIMENSIONAL DATA

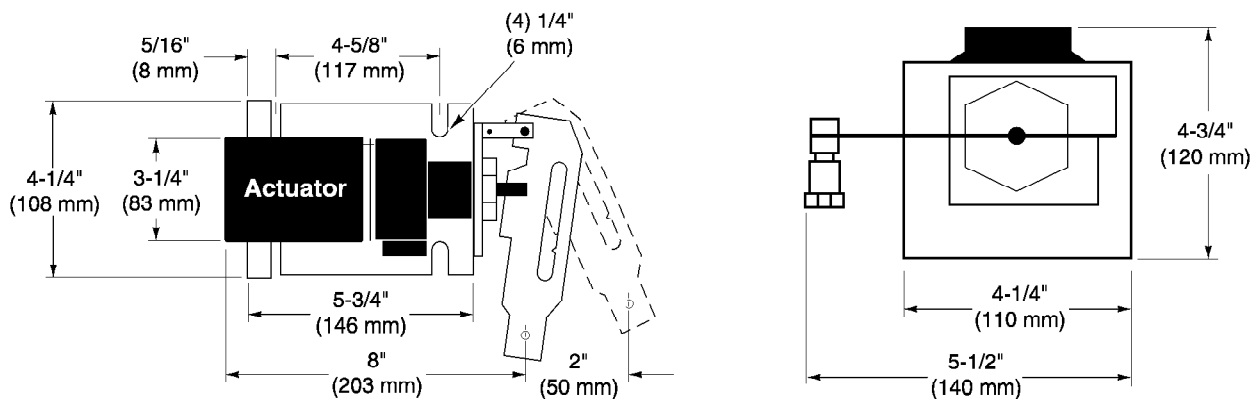

Figure-21 Damper Linkage Assembly Dimensions.

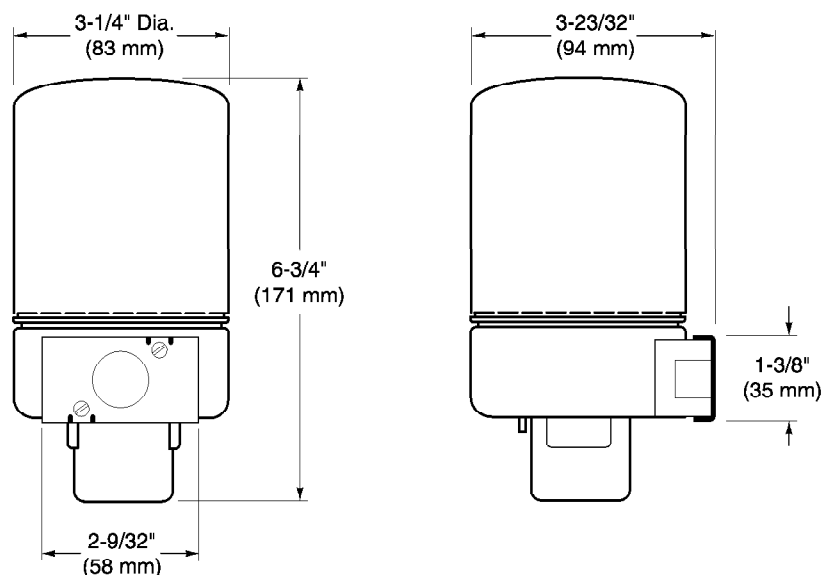

Figure-22 Actuator Dimensions.