



APPLICATION

The M556 piston damper actuator, post mounted, is designed for use in a pneumatic control system to position an air control damper in response to a signal from a pneumatic controller. These actuators can be used for either proportional or two position applications. Other applications include the control of variable fan inlet vanes, centrifugal refrigeration compressor inlet vanes and butterfly valves.

The M573 & M574 Series Piston Damper Actuators are used in pneumatic control systems to position automatic air dampers upon receipt of an air pressure signal from a control device. These actuators can be used for either proportional or two position applications.

The M573 & M574 actuators are equipped with right angle brackets and are adaptable to air conditioning, multi-zone, heating, ventilating, fan coil units, unit ventilators and mixing boxes.

SPECIFICATIONS

Construction:

Housing, Glass filled nylon
Diaphragm, Neoprene, rolling type

Stroke: See Table 1

Spring: Retract actuator shaft on loss of air pressure

Maximum Damper Area: See Table 2

Environment:

Ambient Temperature Limits, -20 to 140°F (-29 to 60°C)

Supply Air Pressure: Clean, dry, oil free air required (ref. EN-123).

Nominal, 20 psig(138 kPa)
Maximum, 30 psig(207 kPa)

Air Consumption (Positioner Models): 0.017 scfm

Connections: Barbed fitting for 1/4" O.D. plastic tubing

Mounting: (See Mounting Instructions).

Dimensions: See Figures 2, 3 & 5

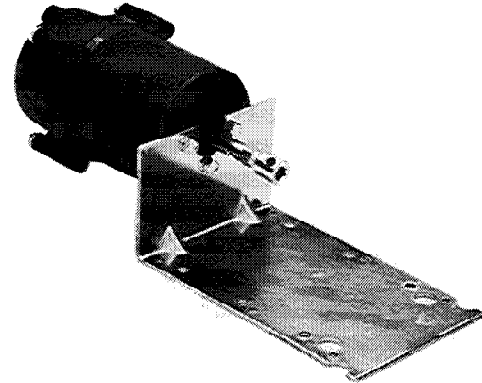

M573/M574 Right Angle Mounted
Shown Without Positive Positioner



M556 Shown With Positive Positioner

ACCESSORIES & REPLACEMENT PARTS

AM-111	Slotted crank arm for 5/16" shaft
AM-112	Slotted crank arm for 3/8" shaft
AM-113	Slotted crank arm for 1/2" shaft
AM-115	Slotted crank arm for 7/16" shaft
AM-122	Straight connector
AM-123	Damper clip
AM-125	5/16" x 20" damper rod
AM-125-048	5/16" x 48" damper rod
AM-132	Ball joint connector
N800-0555-P	Positioner kit with 5 & 10 psi springs
N800-1414	3-hole crank arm for 3/8" shaft
N800-1415	3-hole crank arm for 1/2" shaft

Table 1. Specifications

3" Stroke (7 sq.in.)	4" Stroke (11 sq.in.)	6" Stroke (24.8 sq.in.)	Spring Range PSIG	Mounting	Description
M573-3108	M574-3208	-	5 - 10	Right Angle	Includes Right Angle Mounting Bracket and Ball Joint
M573-5108	M574-5208	-	8 - 13		
M573-1108	M574-1208	-	8 - 13		
M573-3111	M574-3211	-	5 - 10		Includes Right Angle Mounting Bracket, Ball Joint, Push Rod and Crank Arm for 1/2" Damper Shaft
M573-5111	M574-5211	-	8 - 13		
M573-1111	M574-1211	-	8 - 13		
-	-	M556-51	8 - 13	Post Mount	Includes Mounting Plate and Post, Adjustable Damper Crank Arm and Clamp for 1/2" Damper Shaft
-	-	M556-14*	8 - 13		

* A 10 psi span positive positioner spring is also supplied with the actuator, attached to the feedback arm.

Table 2. Maximum Damper Area (@ 1000 FPM)

Actuator	Control	Sq. Ft. (Sq. M)
M556 Series (28.4 sq. in.)	Proportional	75 (7.0)
	Two-Position	90 (8.4)
M573 Series (7 sq. in.)	Proportional	12 (1.1)
	Two-Position	15 (1.4)
M574 Series (11 sq. in.)	Proportional	25 (2.3)
	Two-Position	30 (2.8)

PRE-INSTALLATION

Inspection

Visually inspect the carton for damage. If damaged, notify the appropriate carrier immediately. Visually inspect the device for obvious damage due to shipping. Return damaged parts.

Required Installation Items

- Piping diagrams
- Tools (not provided)
 - Appropriate screwdriver(s) for mounting screws
 - Appropriate wrench(s) for mounting bolts and nuts.
- Mounting screws (not provided)
- Appropriate accessories

INSTALLATION

CAUTION

1. Installer must be a qualified, experienced technician.
2. Make all connections in accordance with the piping diagram.
3. Do not locate the device in areas subjected to excessive vibration or corrosive atmospheres.
4. Do not exceed ratings of the device.

WARNING

1. Improper installation could result in a hazardous condition
2. These actuators contain a powerful spring under compression. Because of this, they should be repaired, if necessary, only by a qualified controls expert.

Clean, Dry Oil Free Air Supplies for Pneumatic Systems

CAUTION

A refrigerated air dryer, particulate filter and a coalescing filter will provide clean, dry, oil free air required (reference EN-123).

Compressor oil must be non-paraffin mineral base or naphtha base. **Synthetic or paraffin base oils will destroy pneumatic controls and void the warranty.**

POSITIVE POSITIONER PIPING

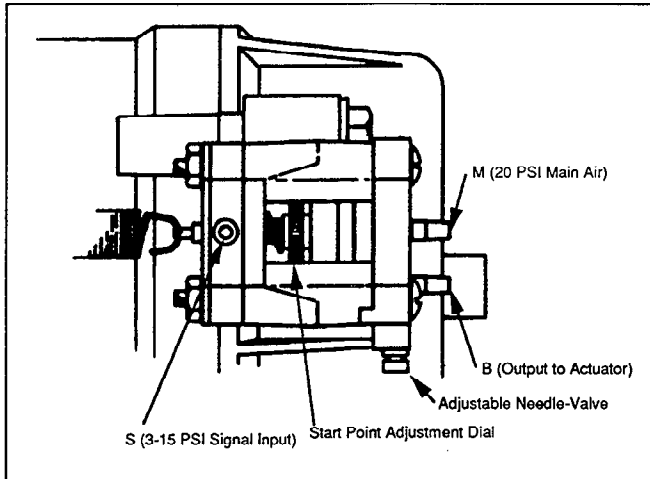

Figure 1. Positioner Adjustment and Port Connections

POSITIVE POSITIONER ADJUSTMENT

See Figure 1.

Span

The signal pressure change required to produce full actuator stroke is determined by the feedback spring. Cataloged models are supplied with factory installed 5 psi springs. M556-14 is also supplied with a 10 psi spring attached to the feedback arm.

Start Point

The signal pressure at which the actuator shaft begins to move is adjustable 3 to 12 psig by rotating the recessed brass knurled dial in the center of positioner.

The start point of the actuator may be adjusted by setting the signal pressure to the desired value and turning the recessed knurled wheel by hand until the actuator shaft begins to move. Turning the wheel outward (toward the spring) raises the start point.

The positioner requires a signal connection to "S" and a main air connection to "M". The positioner output, located above needle valve, is connected to the actuator signal port.

Adjustable Needle-Valve

Needle-valve allows the adjustment of the rate of actuator movement.

With this needle-valve, 3", 4" and 6" actuators may be adjusted with a small blade screw driver, if required, to:

Give the actuators the same relative rate of movement.

This makes it possible, for example, to have outside, return and relief damper on an air handling unit move "together", rather than at different rates. This is especially important -

- When large air handling units are started and stopped.
- When the dampers are switched from "summer" to "winter" operation (or vice versa).

Both of the above examples can cause large damper movements.

A narrower controller throttling range frequently can be used if the actuators are adjusted to move slowly.

This is important for -

- Controlling supply air static pressure with a vortex damper.
- Controlling mixed air temperature with outside, return and relief dampers.
- Controlling space static pressure with one or more relief dampers.

MOUNTING INSTRUCTIONS

M556

External Mounting

See Figure 2

Whenever feasible, an M556 piston actuator operating an air control damper should be mounted external to a duct by means of its standard swivel post and plate. If necessary, the mounting surface should be reinforced to withstand the stroke force of more than 700 pounds that the M556 can exert.

When ordered properly, a control damper will have one or more shaft extensions for the required number of actuators. These extensions will be in their retracted or "stored" positions when shipped and must be extended and locked in position with their set screws or through bolts.

Before the actuator is mounted, the effective length of its threaded crank arm should be adjusted to provide the required damper rotation for full stroke (See table in Figure 2). In addition, the "normal" position of the damper blades (open or closed when signal air is removed and the actuator piston retracts) and direction of shaft rotation as the piston is extended must be determined to establish the orientation of the actuator. If this orientation causes the positioner (when furnished) to be located on the same side of the actuator as the crank arm, there may be interference between the crank arm and the feedback arm during operation. In this event, the relationship between the mounting plate and the positioner should be reversed by temporarily disconnecting the factory tubing connection, swinging the mounting post 180° with respect to the actuator housing and then re-connecting the tubing.

After the above steps have been completed, the crank arm clevis can be slipped onto the damper shaft extension without clamping and the position of the mounting plate can be determined by forming a right triangle (See Figure 2), with the hypotenuse being the "effective length" of the threaded crank arm and the base (along the centerline of the actuator) being one-half of the actuator stroke (3", 76 mm). The mounting plate can then be attached to the duct with suitable fasteners, using care not to obstruct the movement of the damper blades.

NOTE

Note that the actuator need not be mounted at a right angle to the **damper frame**.

The final installation step of locking the crank arm to the damper shaft extension should be done when control air is available or by means of a squeeze bulb:

- a. For a normally closed damper, apply air pressure to the actuator equal to the **low** end of its spring range, e.g.: 8 psig (55 kPa) for an 8 to 13 psig (55 to 90 kPa) spring, then close the damper blades against their stops; a slot in the end of the extension shaft indicates blade position. After assuring that it is parallel to the duct surface, clamp the crank arm to the extension shaft by tightening the outermost crank arm nut. When air pressure is removed from the actuator, its residual low end spring force will provide additional damper close-off pressure.
- b. For a normally open damper, apply air pressure to the actuator equal to the **high** end of its spring range, e.g.: 13 psig (90 kPa) for an 8 to 13 psig (55 to 90 kPa) spring, then close the damper blades against their stops. Clamp the crank arm to the extension shaft as described above. Signal pressure above the spring range will then provide additional close-off force.

NOTE

If an actuator is furnished with a positive positioning relay, the final installation steps described above should be done with the positioner's output line disconnected and the signal air applied directly to the actuator housing. (See Positive Positioner Adjustment .)

Miscellaneous Mounting

M556 actuators may be utilized for other applications, such as:

Internal Air Damper Control

These applications are non-standard. When required, internal mounting of M556 actuators should be coordinated with the damper manufacturer.

Fan Scroll Inlet Van Control

These field applications must be custom-engineered, utilizing the fan manufacturer's data for torque, stroke, mounting and linkage requirements.

Centrifugal Refrigeration Machine Inlet Vane Control

These OEM applications are pre-engineered and the actuators are factory installed.

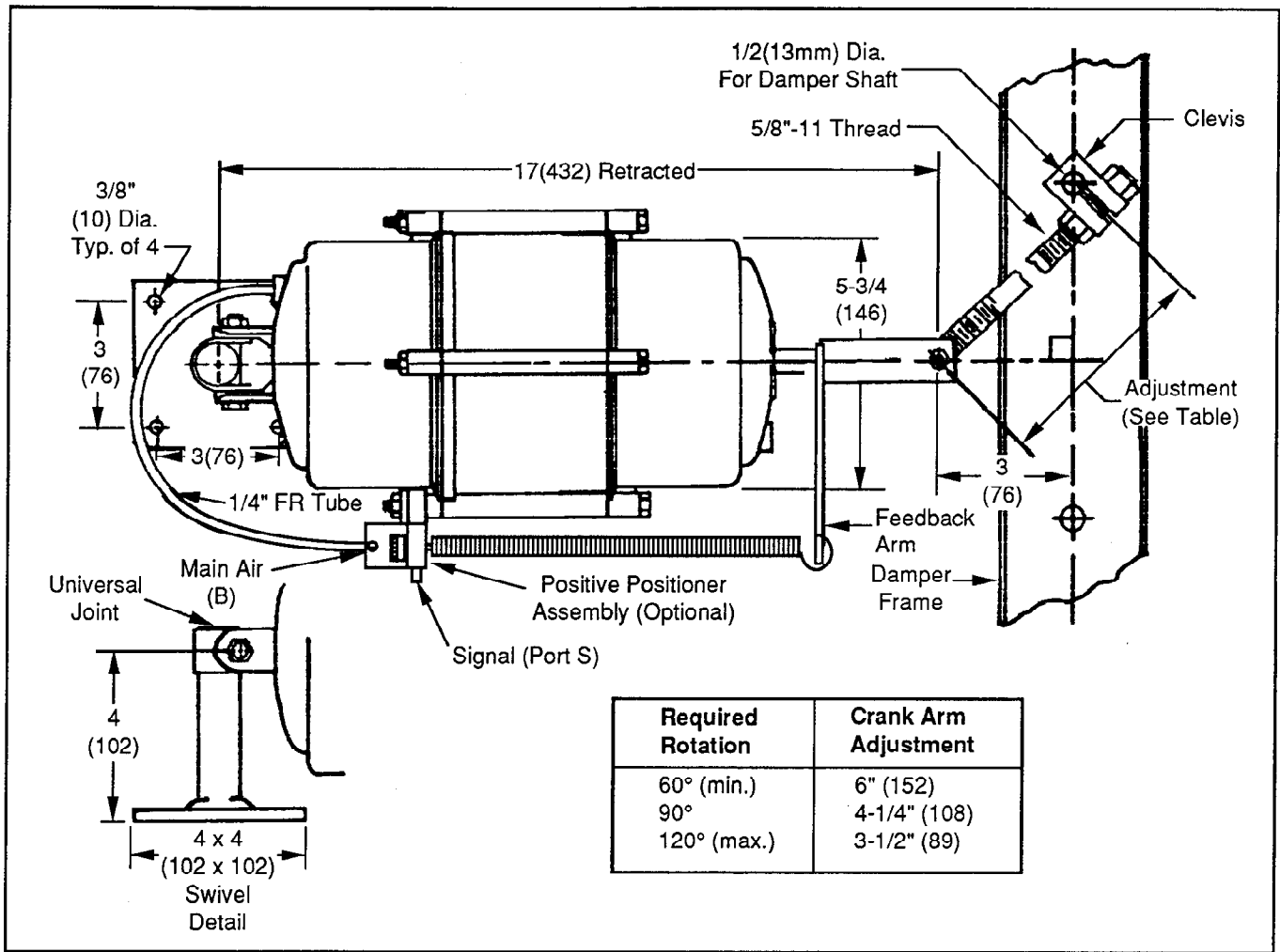

Figure 2. M556 Actuator Mounting Dimensions & External Installation Detail

M573 & M574

External Mounting

See Figures 3 and 4

Whenever feasible, M573 or M574 piston actuators operating air control dampers should be mounted on the external surface of ducts by means of right angle brackets (See Figure 4). By selection of the proper model number (See Specification Table 1), actuators of the proper size (effective area and stroke), spring range and positioner option can be obtained complete with the right angle bracket. The necessary linkage components for driving damper shafts are purchased separately, see Replacement Part and Accessories.

When ordered properly, a control damper will have one or more shaft extensions for the required number of actuators. These extensions will be in their retracted or "stored" positions when shipped and must be extended and locked in position with their set screws or through bolts.

Next, the "normal" position of the damper blades (open or closed when signal air is removed and the actuator piston retracts) and direction of shaft rotation as the piston is extended must be determined to establish the mounting position of the actuator bracket. The standard right angle bracket has two (2) locator holes (dimension E in Figure 3)

for 3"(76mm) stroke actuators and two (2) locator notches (dimension F in Figure 3) for 4"(102mm) stroke actuators; the choice of a locator being based on whether clockwise or counterclockwise rotation is required as the piston shaft is extended by increasing signal pressure.

The pre-assembled crank arm is then slipped over the damper shaft extension and, when properly positioned, the bracket is secured to the duct surface by driving sheet metal screws through its mounting holes, using care not to obstruct movement of the damper blades. If the duct is to be insulated, suitable standoff posts and bolts should be substituted for the sheet metal screws.

NOTE

3" stroke actuators use the middle pivot hole of the crank arm; 4" stroke actuators use the outermost pivot hole.

The final installation step of locking the crank arm to the damper shaft extension should be done when control air is available or by means of a squeeze bulb:

a. For a normally closed damper, apply air pressure to the actuator equal to the **low** end of its spring range, e.g.: 5 psig (34 kPa) for an 5 to 10 psig (34 to 69 kPa) spring, then close the damper blades against their stops; a slot in the end of the extension shaft indicates blade position. After assuring that it is parallel to the duct surface, clamp the crank arm to the extension shaft by tightening the two (2) hexhead screws. When air pressure is removed from the actuator, its residual low end spring force will provide additional damper close-off pressure.

b. For a normally open damper, apply air pressure to the actuator equal to the **high** end of its spring range, e.g.: 10 psig (69 kPa) for an 5 to 10 psig (34 to 69 kPa) spring, then close the damper blades against their stops. Secure the crank arm to the drive shaft as described above. Signal pressure above the spring range will then provide additional close-off force.

NOTE

The standard actuator hardware will rotate a damper 90° for full actuator stroke.

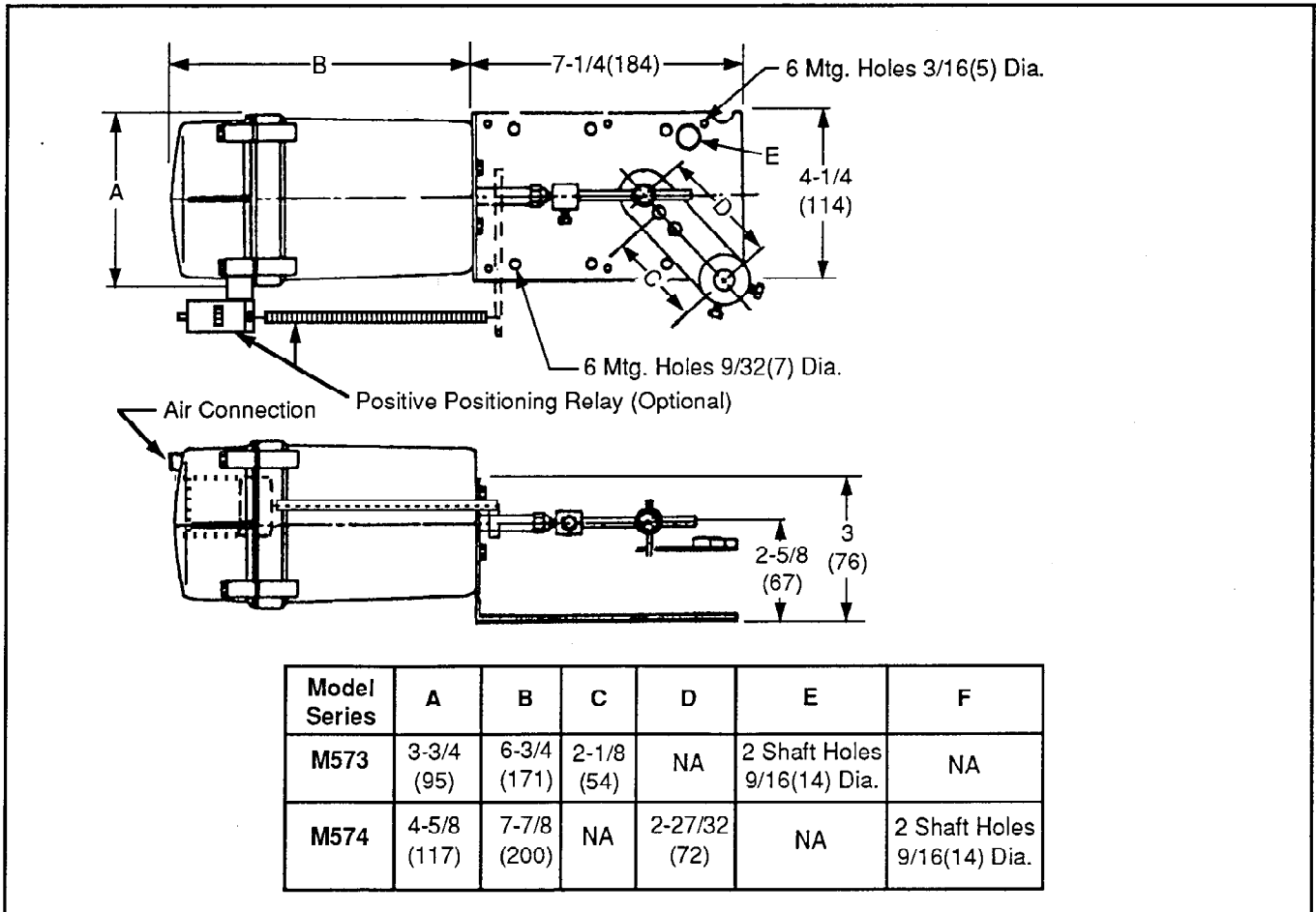

Figure 3. M573 & M574 Right Angle Mounting Dimensions For External Applications

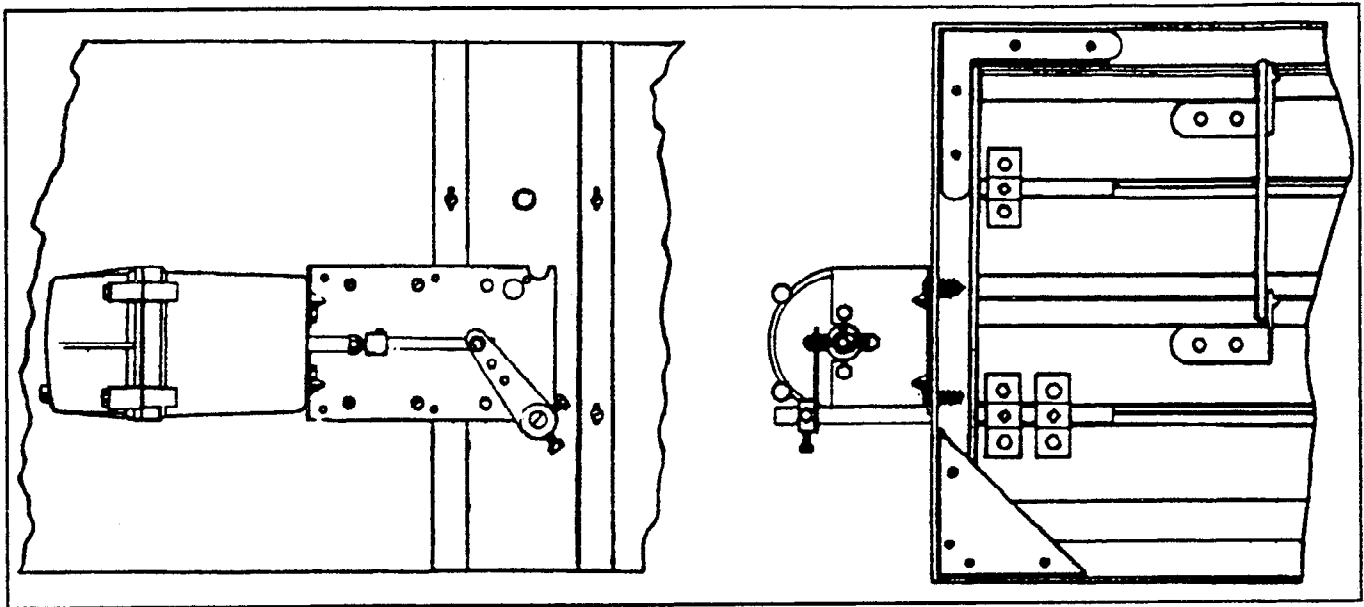

Figure 4. Typical M573/M574 External Actuator Mounting (M574 Shown)

MAINTENANCE

Regular maintenance of the total system is recommended to assure sustained optimum performance.

REPAIR

See Replacement Parts and Accessories

