

### Application

The AV-390 through AV-396 linkages are used to field assemble Invensys Building Systems gear train actuators to VB-7XXX series or VB-9XXX series valve bodies.

- AV-391 and AV-393 are used with current 1/2" to 2" VB-7X1X and obsolete 1/2" to 1-1/4" VB-9X1X valve bodies.
- AV-392 and AV-394 are used with obsolete 1-1/2" and 2" VB-9X1X valve bodies.
- AV-395 and AV-396 are used with current 2-1/2" to 4" VB-9X1X valve bodies.

### Features

- Die cast aluminum mounting bracket.
- Valve position indication provided as standard.

### Applicable Literature

- Invensys Building Systems Cross-Reference Guide, F-23638
- Invensys Building Systems Reference Manual, F-21683
- Invensys Building Systems Application Manual, F-21335
- Invensys Building Systems Catalog, F-25683
- EN-205 Water System Guidelines, F-26080

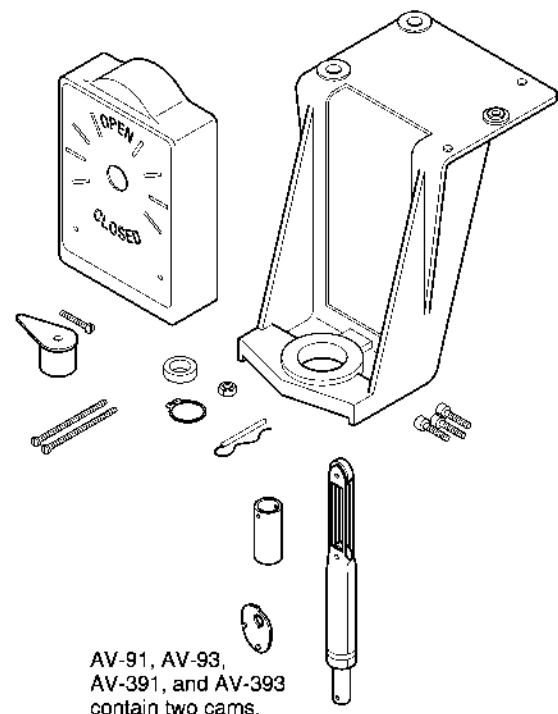

# SPECIFICATIONS

**Table-1 Model Chart.**

| Valve Linkage Model Number | Description   | Stem Force (lb.) |
|----------------------------|---|------------------|
| AV-390                     | Cam, Plunger, and Stem Extension Kit<br>Req. AV-91, AV-92, AV-93, AV-94 | —                |
| AV-391                     | Complete Linkages   | 150              |
| AV-392                     |   |                  |
| AV-393                     |   |                  |
| AV-394                     |   | 300              |
| AV-395                     |   | 150              |
| AV-396                     |   | 300              |

## Temperature Restrictions

Verify that the fluid temperature of the media in the valve versus the ambient temperature at the actuator does not exceed the ratings shown in Table-1.

**Table-2 Restrictions on Maximum Ambient Temperature for Actuators.**

| Maximum Temperature of Media in the Valve<br>(Check Rating of Valve) °F (°C) | Maximum Ambient for Actuator<br>°F (°C) |
|--|---|
| 260 (126)  | 136 (57)                                |
| 281 (138)  | 125 (52)                                |
| 300 to 366 (149 to 185)  | 100 (37)                                |

## Close-off Pressure Rating

Close-off pressure ratings are listed in Table-2 and Table-3. Check the appropriate table to verify that the selected valve, valve linkage, and actuator provide adequate close-off pressure for your application.

The actuator, valve, and valve linkage should be purchased separately. See Table-2 and Table-3 for selections.

## Required Components

## INSTALLATION

### Inspection

Inspect the package for damage. If damaged, notify the appropriate carrier immediately. If undamaged, open the package and inspect the device for obvious damage. Return damaged products.

### Requirements

- Tools (not provided):
  - Appropriate wrenches for stem extensions, lock nuts, packing nuts, and brackets
  - Appropriate screwdriver for actuator mounting screws
  - TOOL-37, 1-5/8" open-ended wrench with a maximum thickness of 3/16"
- Training: Installer must be a qualified, experienced technician

### Caution:

- Avoid locations where excessive moisture, corrosive fumes, or vibration is present.
- Install all two-way valves so that they close against the flow. An arrow on the valve body or a tag indicates the proper flow direction.
- Always install three-way mixing valves with two inlets and one outlet.
- Always install three-way diverting valves with one inlet and two outlets.
- The actuators can be mounted in any position above the centerline of the valve body. For steam applications where the ambient temperature approaches the limit of the actuator, the valve stem should be mounted 45° from vertical. When selecting a location, allow sufficient room for accessories and for service of the product.

**Table-3 Linkage Selection and Valve Close-Off Pressure Ratings for VB-7XXX and VB-9X1X Valve Bodies.**

|   |                             |                                |        |     | TYPICAL ACTUATOR PART NUMBERS   |  |   |  |                 |
|---|-----------------------------|--------------------------------|--------|-----|---|--|---|--|-----------------|
|   |                             |                                |        |     | Normally Closed<br>(Stem Down)<br>MA-318, MA-318-500<br>MA-416, MA-416-500<br>MA-418, MA-418-500<br>MA-419, MA-419-500<br>MP-361, MP-367<br>MP-461-600<br>MP-465, MP5-461 | Normally Open<br>(Stem Up)<br>MA-318, MA-318-500<br>MA-416, MA-416-500<br>MA-418, MA-418-500<br>MA-419, MA-419-500<br>MP-371, MP-377<br>MP-471-600,<br>MP-475, MP5-471 | MP-421<br>MP-422<br>MP-2150-500<br>MP5-2151-500 | No Normal Position<br>MC-351, MC-421, MC-431<br>MC-4211, MC-4311, MC5-4311<br>MP-381, MP5-381, MP-382<br>MP-387, MP-451, MP-452<br>MP-481-600<br>MP-485, MP-486<br>MP-4851, MP5-4851 |                 |
| Minimum Torque/Travel Required  |                             |                                |        |     | 50 lb.-in., 180°  |  |   | 100 lb.-in., 180°  |                 |
| Linkage for 1/2" to 2" Valves   |                             |                                |        |     | AV-391 (AV-390 & AV-91)   |  |   | AV-393 (AV-390 & AV-93)  |                 |
| Linkage for 2-1/2" to 4" Valves   |                             |                                |        |     | AV-395  |  |   | AV-396   |                 |
| VALVE BODY INFORMATION  |                             |                                |        |     | CLOSE-OFF PRESSURE (psi) <sup>a</sup>   |  |   |  |                 |
| Valve Body Part Number  | Description                 | P Code                         | Size   | Cv  |   |  |   |  |                 |
| VB-7211-0-3-P   | 2-Way<br>NPT                | 1                              | 1/2"   | 0.4 | 250   | 250  |   |  |                 |
|   |                             | 2                              |        | 1.3 |   |  |   |  |                 |
|   |                             | 3                              |        | 2.2 |   |  |   |  |                 |
|   |                             | 4                              |        | 5.0 |   |  |   |  |                 |
|   |                             | 5                              | 3/4"   | 5.5 |   |  |   |  |                 |
|   |                             | 6                              |        | 8.5 |   |  |   |  |                 |
|   |                             | 7                              | 1"     | 14  |   |  |   |  |                 |
|   |                             | 8                              |        | 16  |   |  |   |  |                 |
|   |                             | 9                              | 1-1/4" | 22  |   |  |   | 90   | 200             |
| VB-7211-0-4-P   | 2-Way<br>NPT                | 1                              | 1/2"   | 0.4 | 250   | 250  |   |  |                 |
|   |                             | 2                              |        | 1.3 |   |  |   |  |                 |
|   |                             | 3                              |        | 2.2 |   |  |   |  |                 |
|   |                             | 4                              |        | 4.4 |   |  |   |  |                 |
|   |                             | 5                              | 3/4"   | 5.5 |   |  |   |  |                 |
|   |                             | 6                              |        | 7.5 |   |  |   |  |                 |
|   |                             | 7                              | 1"     | 10  |   |  |   |  |                 |
|   |                             | 8                              |        | 14  |   |  |   |  |                 |
|   |                             | 9                              | 1-1/4" | 20  |   |  |   | 90   | 200             |
| VB-7213-0-4-P<br>VB-7214-0-4-P<br>VB-7215-0-4-P<br>VB-7253-0-4-P<br>VB-7273-0-4-P | 2-Way                       | 1                              | 1/2"   | 0.4 | 250   | 250  |   |  |                 |
|   |                             | 2                              |        | 1.3 |   |  |   |  |                 |
|   |                             | 3                              |        | 2.2 |   |  |   |  |                 |
|   |                             | 4                              |        | 4.4 |   |  |   |  |                 |
|   |                             | 5                              | 3/4"   | 5.5 |   |  |   |  |                 |
|   |                             | 6                              |        | 7.5 |   |  |   |  |                 |
|   |                             | 7                              | 1"     | 10  |   |  |   |  |                 |
|   |                             | 8                              |        | 14  |   |  |   |  |                 |
|   |                             | 9                              | 1-1/4" | 20  |   |  |   | 90   | 200             |
|   |                             | 10                             | 1-1/2" | 28  |   |  |   | 65   | 140             |
|   |                             | 11                             | 2"     | 40  |   |  |   | 35   | 80              |
|   |                             | VB-9213-0-4-P<br>VB-9215-0-4-P | 2-Way  | 12  |   |  |   | 2-1/2"   | 65              |
| 13  | 3"                          |                                |        | 85  | 12  | 34   |   |  |                 |
| VB-9213-0-5-P   | 2-Way<br>125 lb.<br>Flanged | 12                             | 2-1/2" | 56  | 20  | 50   |   |  |                 |
|   |                             | 13                             | 3"     | 85  | 12  | 34   |   |  |                 |
|   |                             | 14                             | 4"     | 145 | 6   | 17   |   |  |                 |
| VB-7313-0-4-P<br>VB-7314-0-4-P<br>VB-7315-0-4-P                                   | 3-Way                       | 2                              | 1/2"   | 2.2 | 250   | 250  |   |  |                 |
|   |                             | 4                              |        | 4.4 |   |  |   |  |                 |
|   |                             | 6                              | 3/4"   | 7.5 |   |  |   | 220  |                 |
|   |                             | 8                              | 1"     | 14  |   |  |   | 150  | SU: 150 SD: 140 |
|   |                             | 9                              | 1-1/4" | 20  |   |  |   | 100  | SU: 100 SD: 95  |
|   |                             | 10                             | 1-1/2" | 28  |   |  |   | 60   | SU: 80 SD: 75   |
|   |                             | 11                             | 2"     | 41  |   |  |   | 33   | SU: 200 SD: 190 |
| VB-9313-0-4-P<br>VB-9315-0-4-P  | 3-Way                       | 12                             | 2-1/2" | 67  | 20  | 50   |   |  |                 |
|   |                             | 13                             | 3"     | 91  | 12  | 34   |   |  |                 |
| VB-9313-0-5-P   | 3-Way<br>125 lb.<br>Flanged | 12                             | 2-1/2" | 74  | 20  | 50   |   |  |                 |
|   |                             | 13                             | 3"     | 101 | 12  | 34   |   |  |                 |
|   |                             | 14                             | 4"     | 170 | 6   | 17   |   |  |                 |

<sup>a</sup> kPa = psi x 6.895

**Table-4 Linkage Selection and Valve Close-off Pressure Ratings for Obsolete VB-9XXX Valve Bodies.**

|                                   |   |        |        |     | TYPICAL ACTUATOR PART NUMBERS  |  |  |  |     |
|-----------------------------------|---|--------|--------|-----|--|--|--|--|-----|
|                                   |   |        |        |     | Normally Closed<br>(Stem Down)<br>MA-318, MA-318-500<br>MA-416, MA-416-500<br>MA-418, MA-418-500<br>MA-419, MA-419-500<br>MP-361, MP-367<br>MP-461-600<br>MP-465, MP5-4651 | Normally Open<br>(Stem Up)<br>MA-318, MA-318-500<br>MA-416, MA-416-500<br>MA-418, MA-418-500<br>MA-419, MA-419-500<br>MP-371, MP-377<br>MP-471-600<br>MP-475, MP5-4751 | No Normal<br>Position<br>MP-421<br>MP-422<br>MP-2150-500<br>MP5-2151-500 | No Normal Position<br>MC-351, MC-421, MC-431<br>MC-4211, MC-4311, MC5-4311,<br>MP-381, MP-382, MP-387<br>MP-445-304, MP-451, MP-452,<br>MP-481-600, MP-485, MP-486,<br>MP-4851, MP5-4851 |     |
| Minimum Torque/Travel Required    |   |        |        |     | 50 lb.-in., 180°   |  |  | 100 lb.-in., 180°  |     |
| Linkage for 1/2" to 1-1/4" Valves |   |        |        |     | AV-391 (AV-390 & AV-91)  |  |  | AV-393 (AV-390 & AV-93)  |     |
| Linkage for 1-1/2" & 2" Valves    |   |        |        |     | AV-392 (AV-390 & AV-92)  |  |  | AV-394 (AV-390 & AV-94)  |     |
| VALVE BODY INFORMATION            |   |        |        |     | CLOSE-OFF PRESSURE (psi) <sup>a</sup>  |  |  |  |     |
| Valve Body Part Number            | Description                                       | P Code | Size   | Cv  |  |  |  |  |     |
| VB-9213-0-4-P                     | 2-Way<br>FNPT<br>Composition<br>Disc              | 1      | 1/2"   | 0.4 | 250  | 250  |  |  |     |
|                                   |   | 2      |        | 1.3 |  |  |  |  |     |
|                                   |   | 3      |        | 2.2 |  |  |  |  |     |
|                                   |   | 4      |        | 3.6 |  |  |  |  |     |
|                                   |   | 5      | 3/4"   | 5   |  |  |  |  |     |
|                                   |   | 6      |        | 6.2 |  |  |  |  |     |
|                                   |   | 7      | 1"     | 8.2 |  |  |  |  |     |
|                                   |   | 8      |        | 11  |  |  |  |  |     |
|                                   |   | 9      | 1-1/4" | 16  |  |  |  | 90   | 200 |
|                                   |   | 10     | 1-1/2" | 25  |  |  |  | 65   | 140 |
|                                   |   | 11     | 2"     | 40  |  |  |  | 35   | 80  |
| VB-9253-0-4-P                     | 2-Way<br>FNPT<br>Stainless<br>Trim<br>Teflon Disc | 1      | 1/2"   | 0.4 | 250  | 250  |  |  |     |
|                                   |   | 2      |        | 1.3 |  |  |  |  |     |
|                                   |   | 3      |        | 2.2 |  |  |  |  |     |
|                                   |   | 4      |        | 3.6 |  |  |  |  |     |
|                                   |   | 5      | 3/4"   | 5   |  |  |  |  |     |
|                                   |   | 6      |        | 6.2 |  |  |  |  |     |
|                                   |   | 7      | 1"     | 8.2 |  |  |  |  |     |
|                                   |   | 8      |        | 11  |  |  |  |  |     |
|                                   |   | 9      | 1-1/4" | 16  |  |  |  | 90   | 200 |
|                                   |   | 10     | 1-1/2" | 25  |  |  |  | 65   | 140 |
|                                   |   | 11     | 2"     | 40  |  |  |  | 35   | 80  |
| VB-9273-0-4-P                     | 2-Way<br>FNPT<br>Stainless<br>Trim<br>No Disc     | 1      | 1/2"   | 0.4 | 250  | 250  |  |  |     |
|                                   |   | 2      |        | 1.3 |  |  |  |  |     |
|                                   |   | 3      |        | 2.2 |  |  |  |  |     |
|                                   |   | 4      |        | 3.6 |  |  |  |  |     |
|                                   |   | 5      | 3/4"   | 5   |  |  |  |  |     |
|                                   |   | 6      |        | 6.2 |  |  |  |  |     |
|                                   |   | 7      | 1"     | 8.2 |  |  |  |  |     |
|                                   |   | 8      |        | 11  |  |  |  |  |     |
|                                   |   | 9      | 1-1/4" | 16  |  |  |  | 90   | 200 |
|                                   |   | 10     | 1-1/2" | 25  |  |  |  | 65   | 140 |
|                                   |   | 11     | 2"     | 40  |  |  |  | 35   | 80  |
| VB-9313-0-4-P                     | 3-Way<br>Mixing<br>FNPT                           | 2      | 1/2"   | 2   | 250  | 250  |  |  |     |
|                                   |   | 4      |        | 4   |  |  |  |  |     |
|                                   |   | 6      | 3/4"   | 6.8 |  |  |  |  |     |
|                                   |   | 8      | 1"     | 12  |  |  |  |  |     |
|                                   |   | 9      | 1-1/4" | 16  |  |  |  | 95   | 190 |
|                                   |   | 10     | 1-1/2" | 33  |  |  |  | 33   | 75  |
|                                   |   | 11     | 2"     | 55  |  |  |  |  |     |
| VB-9323-0-4-P                     | 3-Way<br>Diverging<br>FNPT                        | 4      | 1/2"   | 6   | 250  | 250  |  |  |     |
|                                   |   | 6      | 3/4"   | 8   |  |  |  |  |     |
|                                   |   | 8      | 1"     | 12  |  |  |  |  |     |
|                                   |   | 9      | 1-1/4" | 16  |  |  |  |  |     |
|                                   |   | 10     | 1-1/2" | 30  |  |  |  |  |     |
|                                   |   | 11     | 2"     | 42  |  |  |  |  |     |

<sup>a</sup> kPa = psi x 6.895

## ASSEMBLY PROCEDURE

The following ***bold italic*** headings are instructions for step one. Select the specific AV-3XX instructions for the proper valve size. After the mounting bracket is attached, proceed to step 2. See page 8.

**Note:** Position the bracket on the valve in such a way as to make it convenient to wire the actuator.

### **AV-391 or AV-393 Valve Linkage for 1/2" to 2" VB-7XXX and Obsolete 1/2" to 1-1/4" VB-9XXX Valve Bodies**

1. Mount the bracket on the valve body by screwing the mounting nut into the mounting bracket. Tighten the hex mounting nut, using a 1-5/8" open-ended wrench with a maximum thickness of 3/16" (TOOL-37). See Figure-1.

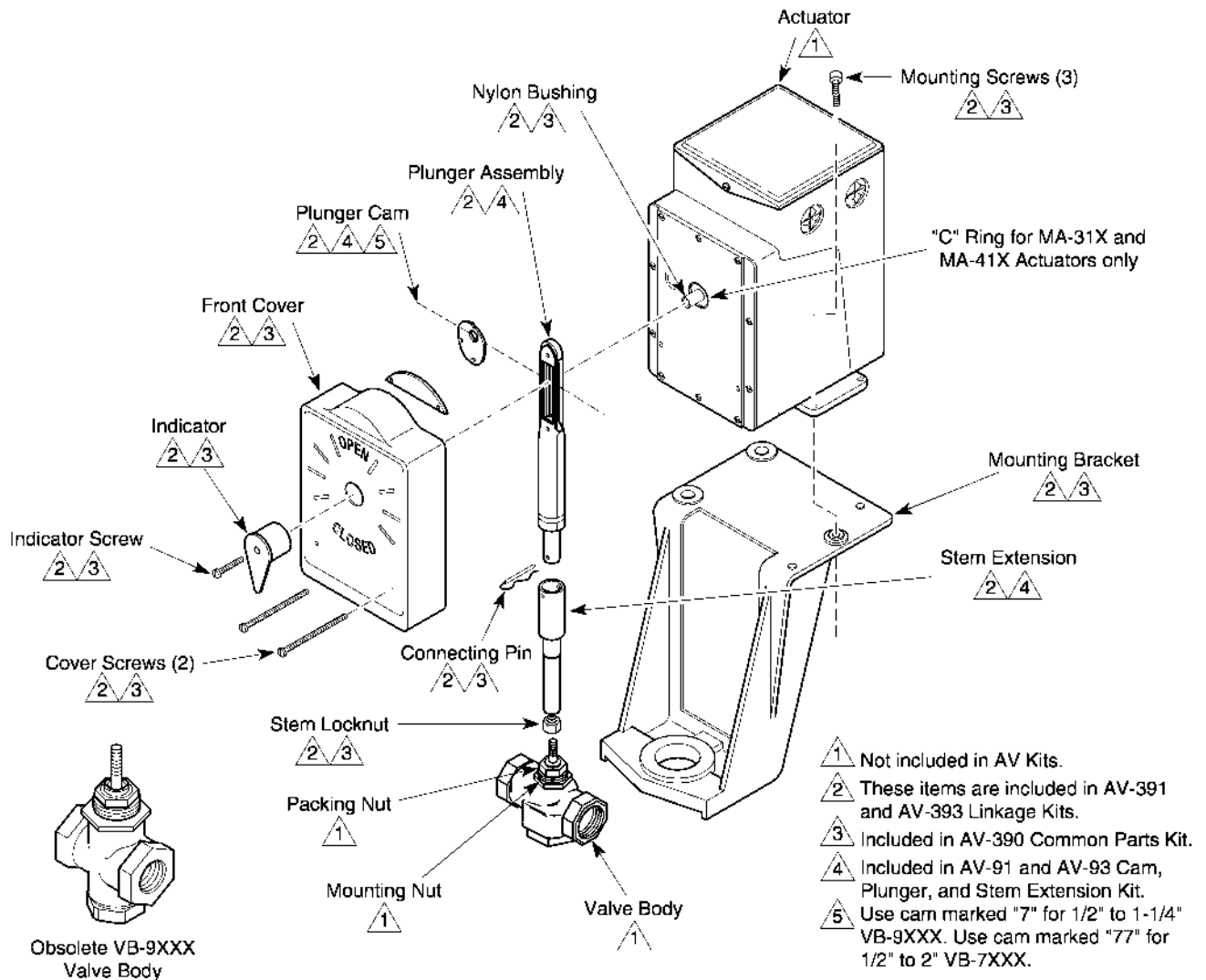

Figure-1 Valve Linkages for 1/2" to 2" VB-7XXX and Obsolete 1/2" to 1-1/4" VB-9XXX Valve Bodies.

**AV-392 or AV-394 Valve Linkage for Obsolete 1-1/2" to 2" VB-9XXX Valve Bodies**

1. Mount the bracket onto the valve body as follows:

- a. For Style A VB-9XXX valve bodies, mount the bracket on the valve body by screwing the mounting nut into the mounting bracket. Tighten the hex mounting nut, using a 1-5/8" open-ended wrench with a maximum thickness of 3/16" (TOOL-37). See Figure-1.
- b. For Style B VB-9XXX valve bodies, mount the bracket onto the valve body by removing the bracket nut, placing the bracket on the valve body, and replacing and tightening the valve bracket nut. See Figure-2.

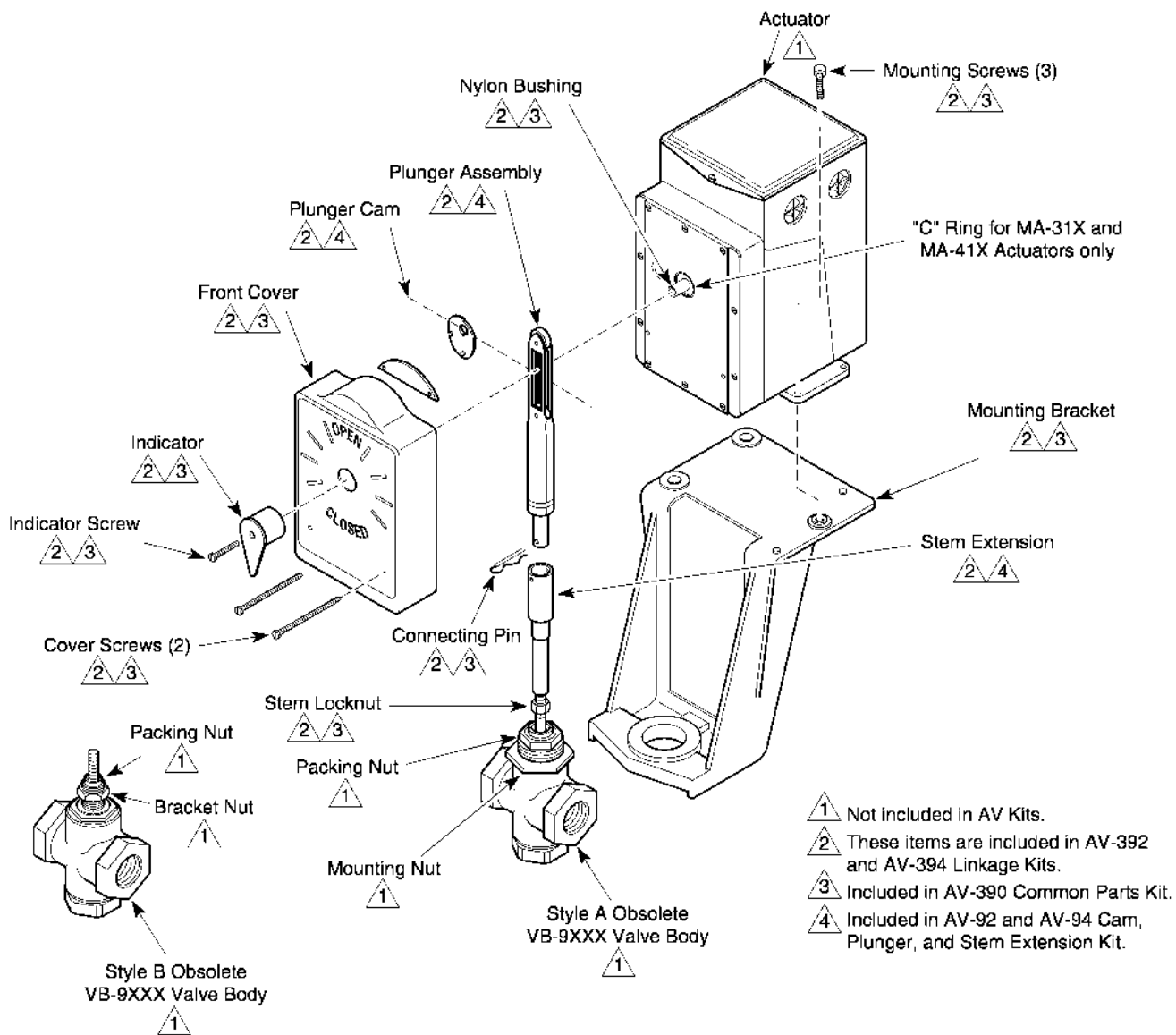

Figure-2 Valve Linkages for Obsolete 1-1/2" to 2" VB-9XXX Valve Bodies.

### AV-395 or AV-396 on Current 2-1/2" to 4" VB-9X1X Valve Bodies

1. Mount the bracket onto the valve body by removing the bracket nut, placing the bracket on the valve body, and replacing and tightening the valve bracket nut. See Figure-3.

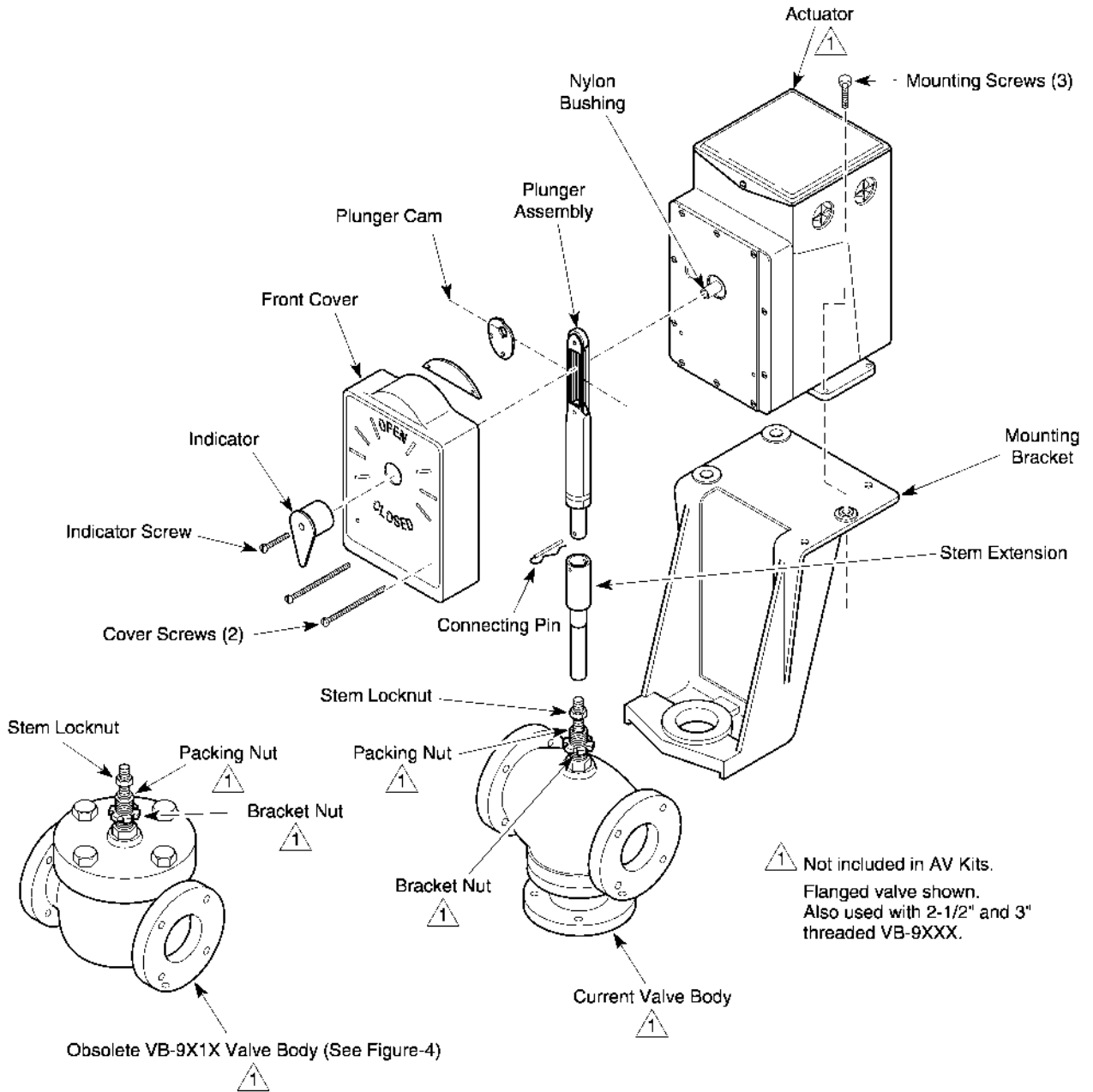

Figure-3 Valve Linkages for Current 2-1/2" to 4" VB-9X1X Valve Bodies.

## AV-395 or AV-396 on Obsolete 2-1/2" to 4" VB-9X13 Valve Bodies

See Figure-4 and YBA-651-1 & YBA-652, Valve Packing Kits General Instructions, F-24185 for details.

---

**Caution:** Before the packing nut is removed, the system pressure on the valve must be reduced to zero (0) psig. If the packing nut is removed while there is pressure on the valve, the packing can blow out of the valve.

---

1. Mount the bracket onto the valve body as follows:
  - a. Remove the packing nut and the bracket nut.
  - b. Place the bracket onto the valve body.
  - c. Replace and tighten the valve bracket nut.
  - d. Replace the packing nut.

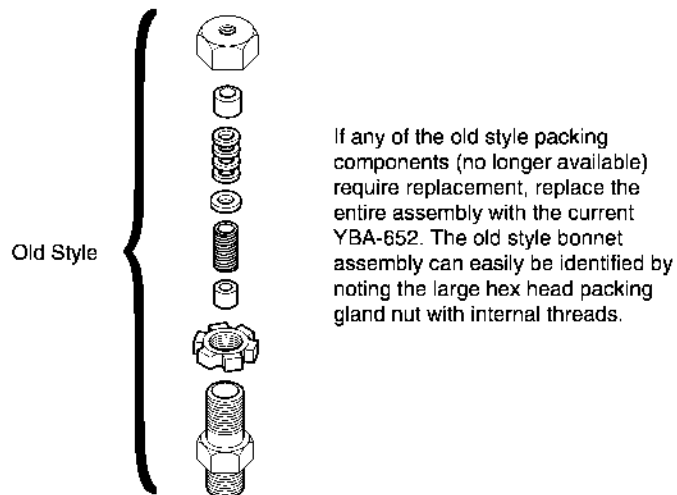

Figure-4 Valve Linkage for Obsolete 2-1/2" to 4" VB-9X13 Valve Bodies.

The following steps are common to all AV-390 valve linkages. Proceed with step 2 after completing step 1 for the selected linkage.

2. Thread the stem lock nut and stem extension down fully onto the valve stem.
3. Place the actuator onto the mounting bracket. Fasten the actuator to the mounting bracket with the three 1/4 - 20 screws. Do not tighten the screws.
4. Place the nylon bushing onto the actuator shaft. (MA-31X and MA-41X actuators require that a "C" ring be installed into the groove on the actuator shaft before placing the nylon bushing onto the shaft.)
5. Position the actuator to the 3:00 (CW) or 9:00 (CCW) position so that the plunger cam is pointing down. Use Figure-5 and Table-4Table-5 to determine whether the 3:00 (CW) or 9:00 (CCW) position is the correct one for the plunger cam to be pointing down for the application.

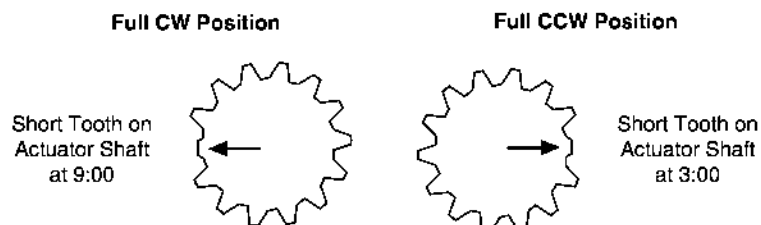
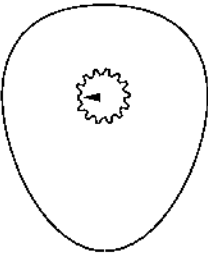
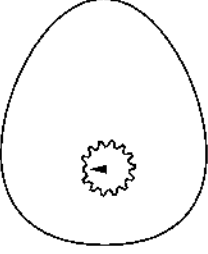
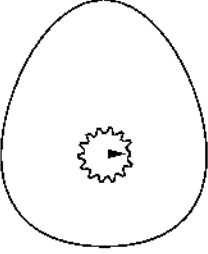
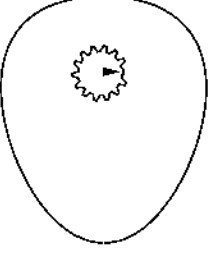

Figure-5 Actuator Shaft Position (Front View).



**Table-5 Actuator Shaft and Cam Position.**

| Actuator Shaft Position                             | Standard Factory Positions of Cam except for Normally Closed Valves w/MA-3XX and MA-4XX Actuators | Optional Cam Position Used to Reverse Control Action (Standard for Normally Closed Valves w/MA-3XX and MA-4XX) |
|---|---|--|
| <b>CW</b><br>Short tooth on actuator shaft at 9:00  | <br>Cam Down     | <br>Cam Up                  |
| <b>CCW</b><br>Short tooth on actuator shaft at 3:00 | <br>Cam Up       | <br>Cam Down                |

- Place the plunger cam in the plunger and slip the plunger cam onto the actuator shaft with the cam pointing down. Consult Table-6 for the proper cam.

**Table-6 Cam Selection.**

| Use Cam Marked | Included in Linkage Kits              | For These Valve Bodies                           | With Nominal Stroke |
|----------------|---------------------------------------|--|---------------------|
| "7"            | AV-91, AV-391, AV-93, AV-393          | 1/2" to 1-1/4" Obs. VB-9XXX                      | 1/2"                |
| "77"           |                                       | 1/2" to 2" VB-7XXX                               |                     |
| "44-2"         | AV-92, AV-392, AV-394, AV-395, AV-396 | 2-1/2" to 4" VB-9XXX<br>1-1/2" & 2" Obs. VB-9XXX | 1"                  |

- Push the valve stem completely down against the lower valve seat.
- Screw the stem extension until the holes in the stem extension and plunger line up.
- Turn the stem extension upward, counterclockwise, into the plunger 2 full turns for 1/2" to 2" valves and 1-1/2 turns for 2-1/2" to 4" valves.
- Raise the actuator up until the connecting pin can be inserted through the holes in the plunger and stem extension.
- Tighten the actuator mounting screws.
- Tighten the lock nut against the stem extension.
- Place the front cover over the plunger assembly and fasten it to the actuator with two self-tapping screws.
- Install the position indicator to the end of the actuator shaft, pointing to "Closed".

## CHECKOUT

1. Drive the actuator so that the valve stem is fully up. If the valve is a three-way, check for plunger compression. See Figure-6.
2. Drive the actuator so that the valve stem is fully down. Check for plunger compression. See Figure-7.

*Note:* Check the plunger spring compression, refer to Figure-6 and Figure-7. The length of the stem extension should be adjusted so that the valve disc seats before the actuator reaches the end of the closing stroke. The balance of the actuator stroke is taken up in the plunger spring compression, which should be approximately 1/16" (1.6 mm). This provides pressure on the disc in the closed position(s) and also compensates for disc and seat wear. On three-way valves, spring compression must be provided on both upper and lower seats.

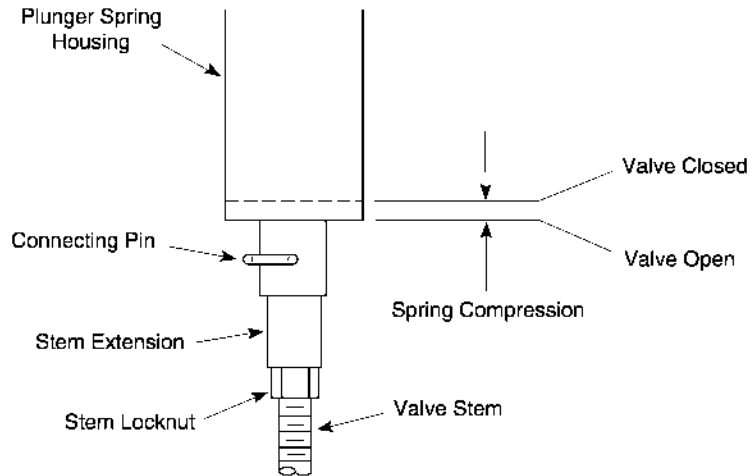

Figure-6 Valve Compression Stem Up.

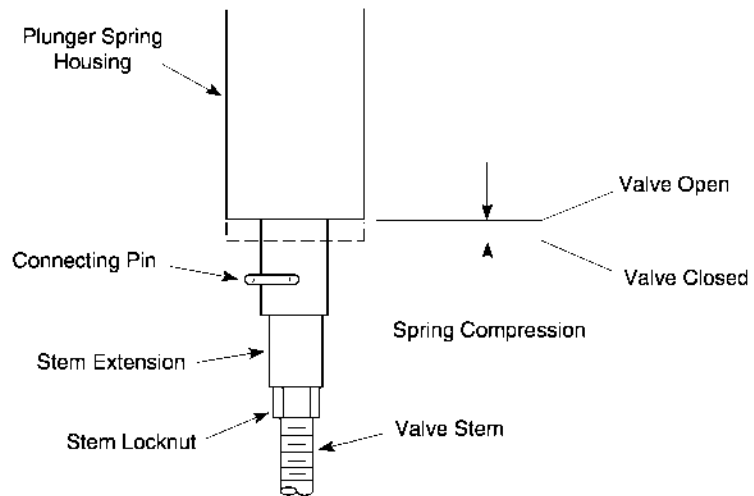

Figure-7 Valve Compression Stem Down.

## MAINTENANCE

Regular maintenance of the total system is recommended to assure sustained optimum performance.

## DIMENSIONAL DATA

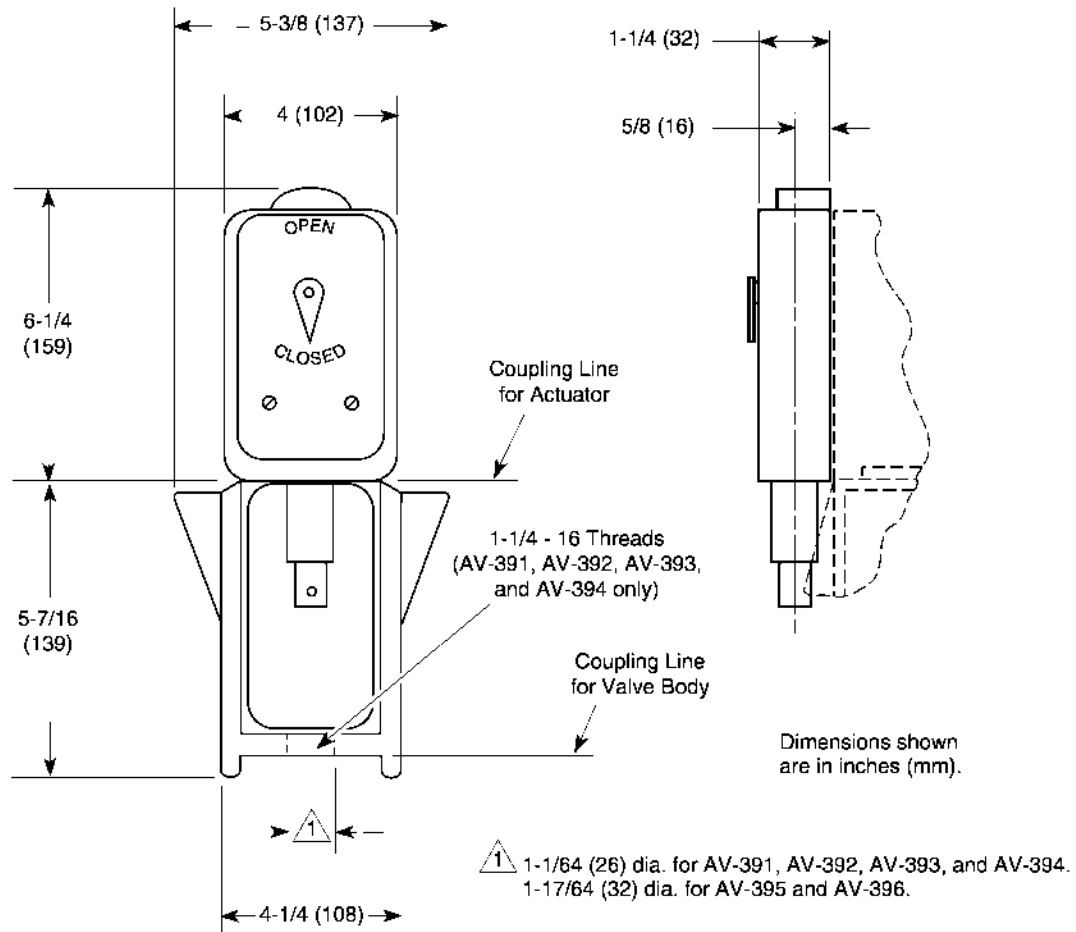

Figure-8 Dimensions of AV-391, AV-392, AV-393, AV-394, AV-395, and AV-396.

