



Invensys Building Systems
1354 Clifford Avenue (Zip 61111)
P.O. Box 2940
Loves Park, IL 61132-2940
United States of America

VB-9223 Series

**2-1/2" and 3" Screwed NPT
2-1/2" to 6" 125 Lb. Flanged
Stem Up to Close (Normally Closed)
Two-Way Valves
General Instructions**

Application

VB-9223 series single seat, stem up to close, two-way valves control water from 40 to 281°F (4 to 138°C) or steam to 281°F (138°C) maximum in heating or air conditioning systems. They are used for two-position or proportional control applications. Valve assemblies require an actuator and a valve linkage that must be purchased separately.



▼ DANGER

Do not use for combustible gas applications. The VB-9223 series valve packings are not rated for combustible gas applications, and if used in these applications, gas leaks and explosions will result.

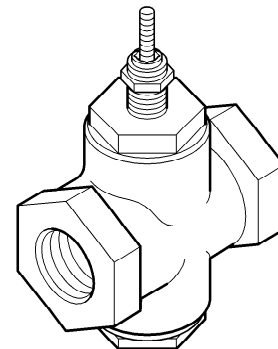

Typical of VB-9223-0-4-P
2-1/2" and 3"

Features

- Valve sizes 2-1/2" to 6".
- 250 psig pressure rating per ANSI Standards (B16.15–1985) for screwed cast bronze bodies.
- 125 psig pressure rating per ANSI Standards (B16.1–1993) for flanged cast iron bodies.
- Spring-loaded TFE packing.

Applicable Literature

- Siebe Environmental Controls Catalog, F-25683
- Siebe Environmental Controls Cross-Reference Guide, F-23638
- Siebe Environmental Controls Reference Manual, F-21683
- Siebe Environmental Controls Application Manual, F-21335
- Siebe Environmental Controls Valve Selection Guide, F-26094
- Control Valve Sizing, F-13755
- Valve Selection Chart for Steam, F-11366
- Valve Selection Chart for Water, F-11080
- EN-205 Water System Guidelines, F-26080

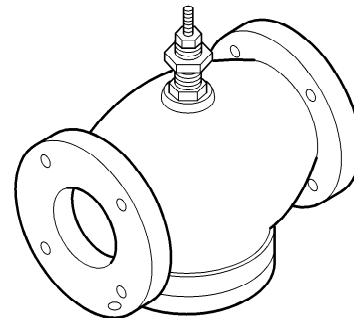

Typical of VB-9223-0-5-P
2-1/2" to 6"

SPECIFICATIONS

Table-1 Specifications/Models.

Specifications			Valve Body Series VB-9223-0-4-P	Valve Body Series VB-9223-0-5-P
Service			Chilled or Hot Water and Steam	
Flow Characteristics (Figure-1)			Equal Percentage	
Sizes			2-1/2" and 3"	2-1/2" to 6"
Type of End Fitting			Screwed NPT	125 lb. Flanged
Valve Materials	Body	Bronze		Iron
	Seat	Bronze		
	Stem	Stainless Steel		
	Plug	Brass		
	Packing	Spring-loaded TFE		
	Disc	Composition		
ANSI Pressure Class (Figure-2)			250 (up to 400 psig below 150°F)	125 lb. Flanged (up to 200 psig below 150°F)
Maximum Inlet Pressure, Steam			35 psig (241 kPa)	
Allowable Control Media Temperature			40 to 281°F (4 to 138°C)	
Allowable Differential Pressure for Water*			35 psi (241 kPa) Max. for Normal Life (refer to "Cavitation Limitations on Valve Pressure Drop" on page 6)	
Allowable Differential Pressure for Steam*			20 psi (138 kPa)	
Temperature Limits of Controlled Media in Valve			40 to 281°F (4 to 138°C)	40 to 281°F (4 to 138°C)
Valve Size	C _v Rating	k _{vs} Rating**	Complete Valve Body Part Number	
2-1/2"	56	48	Not Available	VB-9223-0-5-12
	65	56	VB-9223-0-4-12	Not Available
3"	85	73	VB-9223-0-4-13	VB-9223-0-5-13
4"	145	125	Not Available	VB-9223-0-5-14
5"	235	203		VB-9223-0-5-15
6"	350	302		VB-9223-0-5-16

*Maximum recommended differential pressure in open position. Do not exceed recommended differential pressure (pressure drop) or integrity of parts may be affected. Exceeding maximum recommended differential pressure voids product warranty.

**k_{vs} = m³/h (ΔP = 100 kPa) C_v = k_{vs} × 1.156

Close-off Pressure Rating

The close-off pressure rating is dependent on the size of the valve, valve linkage, and actuator. Consult the appropriate valve linkage general instruction sheet for the close-off ratings.

Normal Position of Valve Assembly

For a valve assembly (valve, linkage, and actuator) to have a normal position, the actuator must be of the spring return type. See Table-2 for spring return position of valve assemblies.

Table-2 Required Compatible Actuators/Linkages.

Actuator Series	Required Valve Linkage		Normal Position
	2-1/2" to 4" Valves	5" & 6" Valves	
MK-6801, MK-6811, MK-6821	AV-495	—	Normally Closed
MK-8801, MK-8811, MK-8821	AV-496		
MK-8901, MK-8911, MK-8921	—	AV-496	

Flow Characteristics

All valves have equal percentage flow characteristics. That is, for equal increments of valve stem stroke, the change in flow rate with respect to valve stroke may be expressed as a constant percent of the flow rate at the time of the change. The change of flow rate with respect to valve stroke is relatively small when the valve plug is near the valve seat and relatively high when the valve plug is nearly wide open. See Figure-1 for typical equal percentage flow characteristics of VB-9223 series valve bodies.

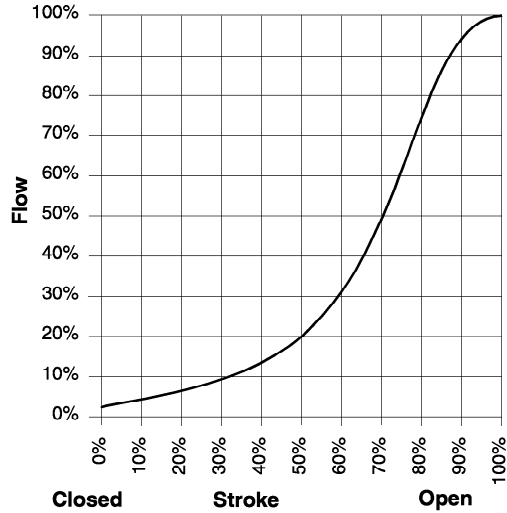

Figure-1 Typical Equal Percentage Flow Characteristics.

Rangeability

Rangeability is the ratio of rated flow to the minimum controllable flow through a valve. The nominal rangeability for VB-9223 series valves is 75:1.

Temperature/Pressure Ratings

See Figure-2 for temperature and pressure ratings. Consult the appropriate valve linkage general instruction sheet for the effect of valve body ambient temperatures on specific actuators. Ratings conform with published values and disclaimer.

VB-9223-0-4-P (Screwed Cast Bronze Body)

Standards: ANSI B16.15-1985

Materials: ASTM B584-93b: UNS C83450, UNS C83600, or UNS C84400

VB-9223-0-5-P (Flanged Cast Iron Body)

Standards: ANSI B16.1-1993

Materials: ASTM A126-93 Class B

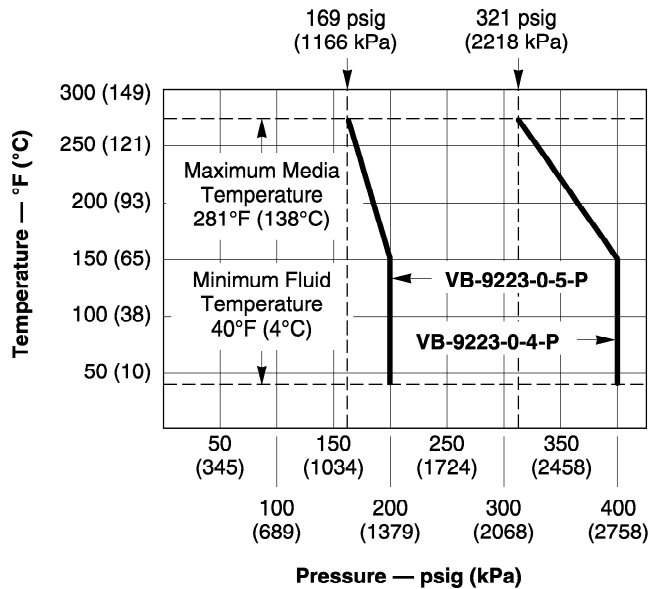

Figure-2 Temperature and Pressure Ratings for VB-9223 Series Valve Bodies.

VALVE SIZING AND SELECTION

Water

Two-position

Two-position control valves are normally selected “line size” to keep pressure drop at a minimum. If it is desirable to reduce the valve below line size, then 10% of “available pressure” (that is, the pump pressure differential available between supply and return mains with design flow at the valve location) is normally used to select the valve.

Proportional

Proportional control valves are usually selected to take a pressure drop equal to at least 50% of the “available pressure.” As “available pressure” is often difficult to calculate, the normal procedure is to select the valve using a pressure drop at least equal to the drop in the coil or other load being controlled (except where small booster pumps are used) with a minimum recommended pressure drop of 5 psi (34 kPa). When the design temperature drop is less than 60°F (33°C) for conventional heating systems, higher pressure drops across the valve are needed for good results (Table-3).

Table-3 Conventional Heating System.

Design Temperature Load Drop °F (°C)	Recommended Pressure Drop* (% of Available Pressure)	Multiplier on Load Drop
60 (33) or More	50%	1 x Load Drop
40 (22)	66%	2 x Load Drop
20 (11)	75%	3 x Load Drop

*Recommended minimum pressure drop = 5 psi (34 kPa).

Secondary Circuits with Small Booster Pumps: 50% of available pressure difference (equal to the drop through load, or 50% of booster pump head).

Water Table

See Table-4 for water capacity of VB-9223 series valves.

Table-4 Water Capacity in Gallons Per Minute for VB-9223 Series.

Valve Body Part Number	C _v Rating	Differential Pressure (ΔP in psi)															
		1	2	3	4	5	6	7	8	9	10	15	20	25	30	35	
VB-9223-0-5-12	56	56	79	97	112	125	137	148	158	168	177	217	250	280	307	331	
VB-9223-0-4-12	65	65	92	113	130	145	159	172	184	195	206	252	291	325	356	385	
VB-9223-0-4-13 VB-9223-0-5-13	85	85	120	147	170	190	208	225	240	255	269	329	380	425	466	503	
VB-9223-0-5-14	145	145	205	251	290	324	355	384	410	435	459	562	648	725	794	858	
VB-9223-0-5-15	235	235	332	407	470	525	576	622	665	705	743	910	1051	1175	1287	1390	
VB-9223-0-5-16	350	350	495	606	700	783	857	926	990	1050	1107	1356	1565	1750	1917	2071	

C_v Equation

$$C_v = \frac{\text{GPM}}{\sqrt{\Delta P}} \quad \Delta P = \left(\frac{\text{GPM}}{C_v} \right)^2 \quad \text{GPM} = C_v \sqrt{\Delta P}$$

Where:

C_v = Coefficient of flow

GPM = U.S. gallons per minute (60°F, 15.6°C)

ΔP = Differential pressure in psi (pressure drop)

Steam

Two-position

Two-position zone valves and direct radiation valves are normally sized using a minimum of 10% of inlet pressure (psig).

Proportional

Proportional control valves are normally sized using:

- For low pressure (15 psig or less), use ΔP of 80% of gauge inlet pressure.
- For steam pressures greater than 15 psig, use ΔP of 42% of absolute (gauge plus 14.7) inlet pressure.
- When the C_v required is between two valve sizes, select the larger size. Do not size steam valves using a pressure drop greater than 42% of the absolute inlet pressure.

Steam Table

See Table-5 for steam capacity of VB-9223 series valves.

Table-5 Steam Capacity in Pounds Per Hour for VB-9223 Series.

Valve Body Part Number	Cv Rating	Differential Pressure (ΔP in psi)															
		2 psig Inlet		5 psig Inlet		10 psig Inlet		15 psig Inlet		20 psig Inlet		25 psig Inlet		30 psig Inlet		35 psig Inlet	
		0.2	1.6	0.5	4	1	8	1.5	12	2	14	2.5	16	3	18	3.5	20
VB-9223-0-5-12	56	305	826	521	1331	818	1942	1093	2448	1359	2860	1620	3271	1879	3683	2136	4095
VB-9223-0-4-12	65	354	958	604	1545	949	2254	1268	2842	1577	3320	1881	3797	2181	4275	2480	4753
VB-9223-0-4-13 VB-9223-0-5-13	85	463	1253	790	2021	1241	2947	1658	3716	2062	4341	2459	4966	2852	5590	3243	6215
VB-9223-0-5-14	145	790	2138	1348	3447	2118	5028	2829	6340	3518	7405	4195	8471	4865	9536	5532	10,602
VB-9223-0-5-15	235	1281	3465	2184	5587	3432	8149	4585	10,275	5701	12,002	6799	13,729	7885	15,455	8965	17,182
VB-9223-0-5-16	350	1907	5161	3253	8321	5112	12,136	6829	15,303	8491	17,875	10,126	20,447	11,744	23,019	13,352	25,591

C_v Equation

$$C_v = \frac{QK}{3\sqrt{\Delta P \cdot P_2}} \qquad Q = \frac{3C_v\sqrt{\Delta P \cdot P_2}}{K}$$

Where:

C_v = Coefficient of flow

Q = Lbs. per hour of steam

ΔP = Differential pressure in psi (pressure drop)

P2 = Outlet pressure in psia (absolute) (P2 = Inlet pressure + 14.7 – ΔP)

K = 1 + (0.0007 x °F superheat) (K = 1 for saturated steam)

Cavitation Limitations on Valve Pressure Drop

A valve selected with too high a pressure drop can cause erosion of discs and/or wire drawing of the seat. In addition, cavitation can cause noise, damage to the valve trim (and possibly the body), and choke the flow through the valve.

Do not exceed the maximum differential pressure (pressure drop) for the valve selected.

The following formula can be used on higher temperature water systems, where cavitation could be a problem, to estimate the maximum allowable pressure drop across the valve:

$$P_m = 0.5 (P_1 - P_v)$$

Where:

P_m = Maximum allowable pressure drop

P_1 = Absolute inlet pressure (psia)

P_v = Absolute vapor pressure (refer to Table-5 or Table-6)

NOTE

Add 14.7 psi to gauge supply pressure to obtain absolute pressure value.

For example, if a valve is controlling 200°F water at an inlet pressure of 18 psig, the maximum pressure drop allowable would be:

$$P_m = 0.5 [(18 + 14.7) - 11.53] = 10.6 \text{ psi}$$

(Vapor pressure of 200°F water is 11.53 psi.)

If the pressure drop for this valve is less than 10.6 psi, cavitation should not be a problem.

Systems where cavitation is shown to be a problem can sometimes be redesigned to provide lower inlet velocities. Valves having harder seat materials should be furnished if inlet velocities cannot be lowered.

Table-6 Vapor Pressure of Water Table.

Water Temp. (°F)	Vapor Pressure (psig)	Water Temp. (°F)	Vapor Pressure (psig)	Water Temp. (°F)	Vapor Pressure (psig)	Water Temp. (°F)	Vapor Pressure (psig)
40	0.12	90	0.70	140	2.89	190	9.34
50	0.18	100	0.95	150	3.72	200	11.53
60	0.26	110	1.28	160	4.74	210	14.12
70	0.36	120	1.69	170	5.99	220	17.19
80	0.51	130	2.22	180	7.51	230	20.78

Additional Valve Sizing Information

For additional valve sizing information, see:

- CA-28 Control Valve Sizing, F-13755
- Valve Selection Chart Water, F-11080
- Valve Selection Chart Steam, F-11366
- Valve Sizing Slide Rule, TOOL-150

INSTALLATION

Inspection

Inspect the package for damage. If damaged, notify the appropriate carrier immediately. If undamaged, open the package and inspect the device for obvious damage. Return damaged products.

Requirements

- Tools (not provided): Pipe wrenches
- Training: Installer must be a qualified, experienced technician
- Appropriate accessories

CAUTION

- Install the valve with the flow in the direction of the flow arrow ("A" port is the inlet and "AB" port is the outlet).
- Do not exceed the ratings of the device.
- Avoid locations where excessive moisture, corrosive fumes, or vibration are present.

Mounting

1. The valve should be mounted in a weather-protected area in a location that is within the ambient limits of the actuator. When selecting a location, allow sufficient room for valve linkage, actuator, and other accessories and for service of the product.
2. The preferred mounting position for the valve is with the valve stem vertical above the valve body. Avoid mounting the valve so that the valve stem is below horizontal.
3. On steam applications where the ambient temperature approaches the limit of the actuator, the valve stem should be mounted 45° from vertical.
4. The valves must be piped with the "A" port as the inlet and the "AB" port as the outlet.

Screwed Valve Bodies

The VB-9223-0-4 series screwed valve bodies conform to American Standard Taper Pipe Threads (NPT).

1. Apply pipe dope sparingly to all but the last two threads of a properly threaded, reamed, and cleaned pipe. Make sure that pipe chips, scale, etc. do not get into the pipe since this material may lodge in the valve seat and prevent proper closing and opening of the valve.
2. Start the joint by hand screwing the pipe into the valve. If the thread engagement feels "right," turn the pipe by hand as far as it will go.
3. Use a pipe wrench to fully tighten the valve to the pipe. Do not over tighten or strip threads. See Table-7 and Figure-3 for the normal engagement length of the threads. Figure-4 shows a means of tightening the pipe so that the valve is not twisted or crushed.

Table-7 Normal Thread Engagement Between Male Pipe Thread and Valve Body.

Valve Size Inches (NPT)	Normal Engagement	Valve Size Inches (NPT)	Normal Engagement
2-1/2"	15/16"	3"	1"

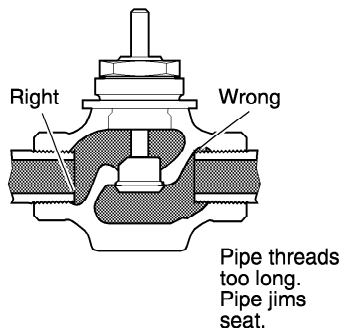

Figure-3 Normal Thread Engagement.

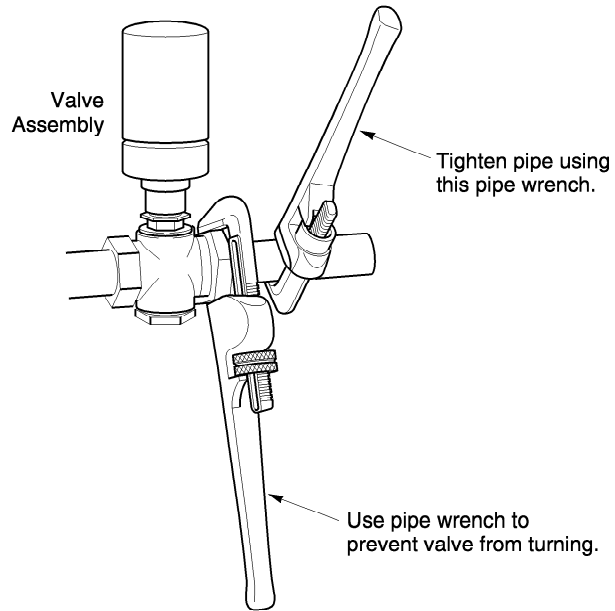

Figure-4 Installation of Screwed End Valves.

Flanged Valve Bodies

The VB-9223-0-5 series flanged valve bodies conform to American Standard 125 Lb. Cast Iron Pipe Flanges. The companion flanges (not provided) should be the same specification as the valve. The 125 lb. flanges have plain flat faces and should not be bolted to a raised faced flange.

1. All parts should be clean to assure the best results.
2. The pipe with the companion flanges installed should be properly supported and aligned. Be sure the companion flange is flush with the face of the valve body flange and lined up squarely.
3. Use a gasket material (not provided) that is recommended for the medium being handled.

▼ CAUTION

Do not apply pipe dope to the valve flange, gasket, or companion flange.

4. Figure-5 shows the proper way a flanged valve should be mounted. See Figure-8 for flange and flange bolt details.

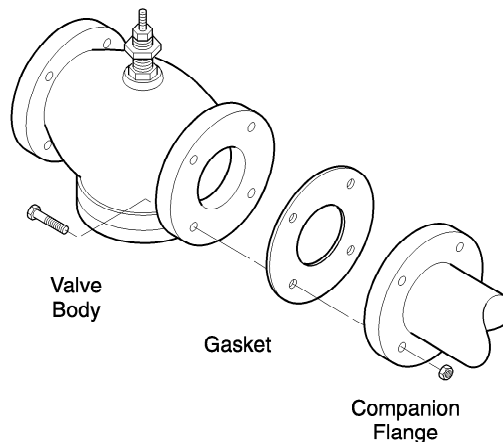

Figure-5 Installation of Flanged End Valves.

CHECKOUT

1. Make sure the valve stem operates freely before installing the valve linkage and the actuator.
2. If the stem does not operate freely, it may indicate that the valve was twisted or crushed during installation or that the stem was bent by rough handling. These conditions may require that the valve be replaced.
3. After the piping is under pressure, check the valve body and the connections for leaks.
4. After the valve linkage and the actuator are installed, check their operation.

MAINTENANCE & FIELD REPAIR

Regular maintenance of the total system is recommended to assure sustained performance. See Table-8 for maintenance kit part numbers.

Table-8 Maintenance Kits for VB-9223 Valves.

Valve Body Part Number	Replacement Packing Assembly	Valve Repair Kit*
VB-9223-0-4-12	YBA-651-1	RYB-922-12
VB-9223-0-4-13		RYB-922-13
VB-9223-0-5-12		RYB-922-12
VB-9223-0-5-13		RYB-922-13
VB-9223-0-5-14		RYB-922-14
VB-9223-0-5-15		RYB-922-15
VB-9223-0-5-16		RYB-922-16

*Kit includes replacement packing and stem & plug assembly.

Water System Maintenance

All heating and cooling systems are susceptible to valve and system problems caused by improper water treatment and system storage procedures. These guidelines are provided to help avoid valve and water system problems resulting from improperly treated water or storage procedures in cooling and hot water systems, and to obtain maximum life from Siebe Environmental Controls valves.

Durability of valve stems and packings is dependent on maintaining non-damaging water conditions. Inadequate water treatment or filtration, not in accordance with chemical supplier/ASHRAE handbook recommendations, can result in corrosion, scale, and abrasive particle formation. Scale and particulates can result in stem and packing scratches and can adversely affect packing life and other parts of the hydronic system.

To maintain non-damaging conditions, follow these guidelines:

- Clean the system prior to start up. Use a nitrite or molybdate-based treatment program.
- Use filtration equipment where needed.
- Properly store off-line systems and monitor water treatment results using corrosion test coupons.
- Follow the advice of a water treatment professional.
- Consult EN-205 for further details.

DIMENSIONAL DATA

Table-9 Dimensions for VB-9223 Series Valves (Figure-6 and Figure-7).

Part Number	Valve Size	Dimensions in Inches (mm)				
		A	B	C	D (Stem Down)	E* (Stroke)
VB-9223-0-4-12	2-1/2"	8-1/2 (216)	3-3/4 (95)	4-1/4 (108)	4-1/8 (105)	15/16 (24)
VB-9223-0-4-13	3"	9-1/2 (241)	4-1/4 (108)	4-3/4 (121)		
VB-9223-0-5-12	2-1/2"	8-1/2 (216)	4-1/8 (105)	3-7/8 (98)		
VB-9223-0-5-13	3"	9-1/2 (241)		4-1/4 (108)		
VB-9223-0-5-14	4"	11-1/2 (292)	5-1/16 (129)	4-7/8 (124)		
VB-9223-0-5-15	5"	13 (330)	6-3/4 (171)	5-1/2 (140)		
VB-9223-0-5-16	6"	14 (356)	7-3/8 (187)	6-3/8 (162)		

*Stroke for rated flow.

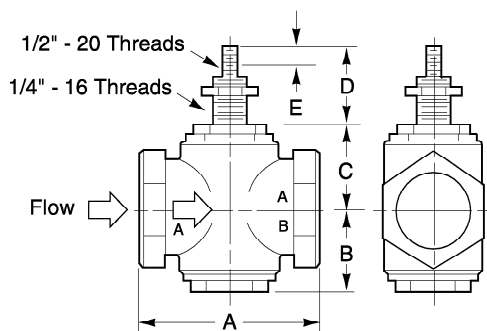

Figure-6 Typical of VB-9223-0-4-P, 2-1/2" and 3" Valve Bodies.

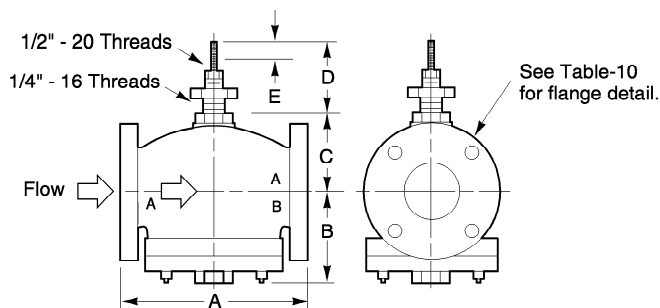

Figure-7 Typical of VB-9223-0-5-P 2-1/2" to 6" Valve Bodies.

Table-10 Flange Detail for American Standard 125 lb. Cast Iron Pipe Flanges (Figure-8).

Nominal Pipe Size	Flanges		Drilling		Bolting		Length of Machine Bolts E
	Flange Diameter A	Flange Thickness B	Diameter of Bolt Circle C	Diameter of Bolt Holes D	Number of Bolts	Diameter of Bolts	
2-1/2"	7"	11/16"	5-1/2"	3/4"	4	5/8"	2-1/2"
3"	7-1/2"	3/4"	6"				
4"	9"	15/16"	7-1/2"				
5"	10"		8-1/2"	7/8"	8	3/4"	3"
6"	11"	1"	9-1/2"				

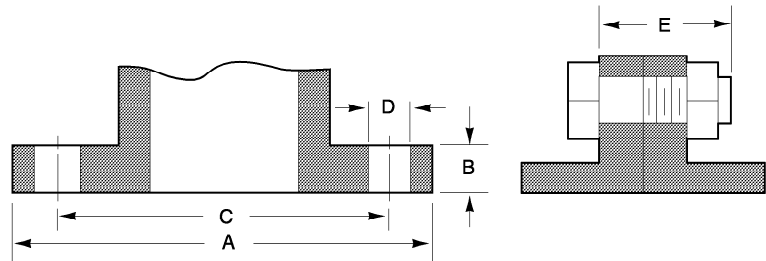

Figure-8 Flange Dimensions.

