

## Electronic Positive Positioning Hydraulic Actuator General Instructions

### Application

The MP-5400 Series Actuators are for electronic proportional control of dampers, valves, or program switches which require the return to normal position upon power interruption. This series is compatible with 2 to 15 Vdc input signals from System 8000™, NETWORK 8000®, and DMS DDC controllers.

### Features

- Proportional actuators controlled by variable Vdc input signal
- Positive positioning
- Spring return
- Fixed 3 Vdc operating span.
- Adjustable 2 to 12 Vdc start point for paralleling or sequencing of actuators.
- 10,000  $\Omega$  or greater input impedance.
- 24 Vac, 120 Vac, and 240 Vac models.
- Available in damper models or base models that require damper or valve linkage.
- Die cast lower housing and painted steel upper housing
- Hydraulic actuator with oil-immersed motor, transducer, and pump.

### Applicable Literature

- Siebe Environmental Controls Cross-Reference Guide, F-23638
- Siebe Environmental Controls Reference Manual, F-21683
- Siebe Environmental Controls Application Manual, F-21335
- Siebe Environmental Controls First Edition Catalog, F-25683
- Engineering Bulletin EN-111, System 8000 Electronic Control, F-15264
- AV-600 Hydraulic Actuator Valve Linkage Kit General Instructions, F-26279
- AV-601 Linkage Extension Kit General Instructions, F-26280
- Material Safety Data Sheet MSDS-3 (Until Feb. 1989)
- Material Safety Data Sheet MSDS-12 (Currently)

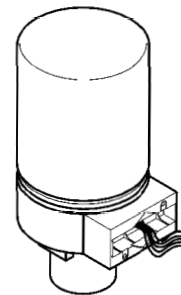

MP-5410 Series  
Valve Actuator

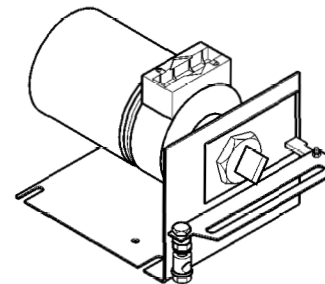

MP-5430 Series  
Damper Actuator



# SPECIFICATIONS

## Actuator Inputs

**Compatible with:** 2 to 15 Vdc from System 8000, NETWORK 8000, or DMS DDC controllers.

**Operating Span,** Approximately 3 Vdc fixed.

**Start Point,** Approximately 6 Vdc fixed.

**Impedance,** 10,000  $\Omega$  or greater.

**Power Input:** Refer to Table-1 and Table-2.

**Connections:** Color-coded 4' (1.2 m) leads.

## Actuator Outputs

**Internal Power Supply,** 20 Vdc, 25 mA.

**Stroke:**

**Damper,** Approximately 2" (51 mm) over a nominal 6 Vdc (fully retracted) to 9 Vdc (fully extended) input range (includes AM-601 linkage).

**Valve,** Approximately 9/16" (14.3 mm) over a nominal 6 Vdc (fully retracted) to 9 Vdc (fully extended) input range.

**Torque:** Refer to Table-1 and Table-2.

**Nominal Damper Area,** Actuator selection should be made in accordance with the damper manufacturer's specifications.

## Environment

**Ambient Temperature Limits:**

**Shipping & Storage,** -40 to 140° F (-40 to 60° C).

**Operating,** -20 to 140° F (-29 to 60° C).

**Damper** -20 to 140° F (-29 to 60° C).

**Valve** Refer to Table-3.

**Humidity:** 5 to 95% RH, non-condensing.

**Location:** NEMA Type 1.

**Agency Listings:**

**UL 873,** Underwriters Laboratories (File #E9429 Category Temperature Indicating and Regulating Equipment).

**CSA,** Canadian Standards Association (File #LR3728).

**European Community,** EMC Directive (89/336/EEC). Low Voltage Directive (72/23/EEC).

**Table-1 Model Chart for Damper Actuators.**

Part Number	Actuator Power Input					Positive Positioner <sup>a</sup>	Timing in Seconds @ 72° F (22° C)			Torque Rating (Extend & Retract) lb.-in. (N-m)
	AC Voltage +10/-15%	Hz		VA	Watts		No Load Stroke		Retract on Power Loss	
		To Extend	To Retract							
MP-5430	120	50	60	18	10	Yes	60	30	15	15 (1.69)
MP-5433	240									

<sup>a</sup> Internal feedback circuitry provides positive positioning of the damper in relation to the controller signal.

**Table-2 Model Chart for Valve Actuators. Also for Damper Actuators with Field Assembled Damper Linkages.**

Part Number	Actuator Power Input					Positive Positioner <sup>a</sup>	Timing in Seconds @ 72° F (22° C)			Required Linkage	
	AC Voltage +10/-15%	Hz		VA	Watts		No Load Stroke		Retract on Power Loss	Damper	Valve
		To Extend	To Retract								
MP-5410	120	50	60	18	10	Yes	60	30	15	AM-601 <sup>b</sup>	AV-600 AV-601 <sup>c</sup>
MP-5411	240										
MP-5413	24										

<sup>a</sup> Internal feedback circuitry provides positive positioning of the valve stem in relation to the controller signal.

<sup>b</sup> With the installation of the AM-601 damper linkage, these valve actuators become functionally the same as the damper actuators listed in Table-1. Refer to Table-1 for the torque rating.

<sup>c</sup> May be required for steam and hot water. Refer to Table-3.

**Table-3 Maximum Allowable Ambient Air Temperature for Valve Actuators.**

Temperature of Media in the Valve Body (Check the Rating of the Valve) °F (°C)	Maximum Allowable Ambient Air Temperature of MP-54XX Series	
	AV-600 (Only for Chilled Water Applications) °F (°C)	AV-600 and AV-601 °F (°C)
366 (180)	Do Not Use	88 (31)
340 (171)		93 (34)
281 (138)		103 (39)
181 (83)		120 (48)
80 (26)		140 (60) <sup>a</sup>

a Maximum allowable ambient temperature of the actuator, minimum -20° F (-29° C).

## ACCESSORIES

### Common

11-1612 1/2" conduit bushing  
 AM-610 Transformer, nipple-mounted, 120/208/240 Vac 50/60 Hz 40 VA (for mounting on conduit box)

### Damper Only

AM-111 Crank arm for 5/16" diameter damper shaft  
 AM-112 Crank arm for 3/8" diameter damper shaft  
 AM-113 Crank arm for 1/2" diameter damper shaft  
 AM-115 Crank arm for 7/16" diameter damper shaft  
 AM-122 Linkage connector straight type  
 AM-123 Damper clip  
 AM-125 5/16" diameter x 20" damper rod  
 AM-125-048 5/16" diameter x 48" damper rod  
 AM-132 Ball joint connector  
 AM-161-3 Damper linkage kit  
 AM-601 Device includes mounting bracket, damper linkage with spring, and AM-122 straight connector. Required to modify (MP-521X series) valve actuators into 2" (51 mm) stroke damper actuators.

### Valve Only

AV-600 Valve linkage  
 AV-601 Valve linkage extension for hot water and steam applications; use with AV-600

### Tools

TOOL-12 Wrench for adjustment of auxiliary switch  
 TOOL-19 Spring compression tool for AV-600  
 TOOL-37 1-5/8" open-end wrench  
 TOOL-202 Manual positioner

# TYPICAL APPLICATIONS (wiring diagrams)

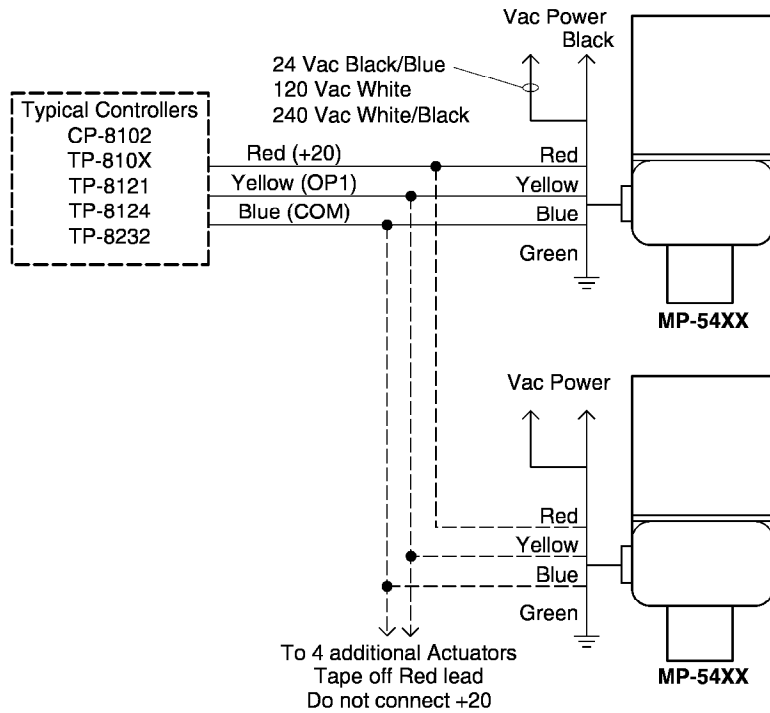
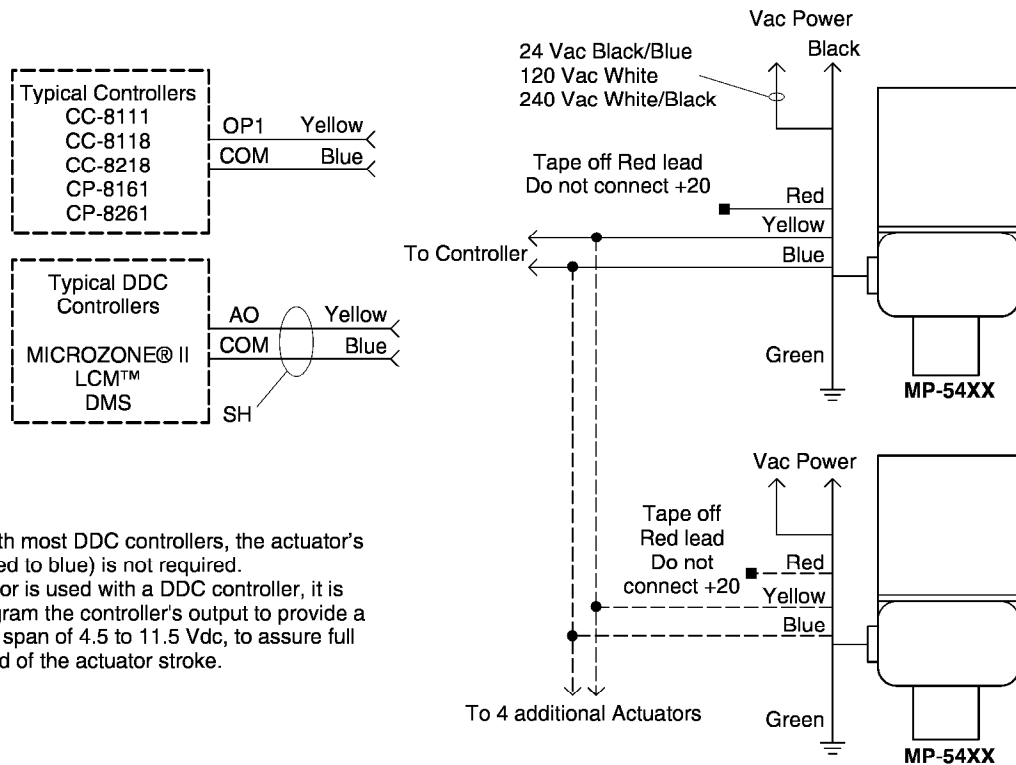

Figure-1 Typical Control Wiring for Up to Six MP-5400 Series Actuators to Controllers Requiring External 20 Vdc Power from the Actuator.



- Note 1: When applied with most DDC controllers, the actuator's 20 Vdc supply (red to blue) is not required.
- Note 2: When this actuator is used with a DDC controller, it is important to program the controller's output to provide a minimum control span of 4.5 to 11.5 Vdc, to assure full travel to each end of the actuator stroke.

Figure-2 Typical Control Wiring for Up to Six MP-5400 Series Actuators to Controllers that Do Not Require 20 Vdc Power from the Actuator.

# INSTALLATION

## Inspection

Inspect the package for damage. If damaged, notify the appropriate carrier immediately. If undamaged, open the package and inspect the device for obvious damage. Return damaged products.

## Requirements

- Job wiring diagrams
- Tools (not provided):
  - Digital Volt-ohm Meter (DVM)
  - Appropriate drill and drill bit for mounting screws
  - Appropriate screw drivers and wrenches
  - Channel lock pliers to remove the knockout from the actuator
  - TOOL-12, Wrench for adjustment of auxiliary switch
  - TOOL-19, Spring compression tool for AV-600
  - TOOL-37, 1-5/8" open-ended wrench
  - TOOL-202, Manual positioner
- Training: Installer must be a qualified, experienced technician



---

**Warning:**

- Disconnect the power supply (line power) before installation to prevent electrical shock and equipment damage.
  - Make all connections in accordance with the wiring diagram and in accordance with national and local electrical codes. *Use copper conductors only.*
- 

**Caution:**

- Static charges produce voltages high enough to damage the electronic components. Follow static electricity precautions when installing or servicing the device(s). Discharge any static electricity you may have accumulated by using wrist straps, or by touching a known, securely grounded object.
  - Do not exceed the ratings of the device(s).
  - Do not apply power to the unit unless the damper linkage and/or the valve assembly have been installed.
  - Avoid locations where excessive oil, dust, moisture, corrosive fumes or vibration, or an explosive atmosphere is present.
  - Do not install insulation on any part of the actuator.
- 

## Mounting

**Caution:** Do not twist or exert any force on the actuator housing during installation. Either turn the base by hand or, if necessary, use a 1-5/8" open-ended wrench (TOOL-37) on the flats provided on the actuator base or the valve body mounting nut. Refer to Figure-3.

---

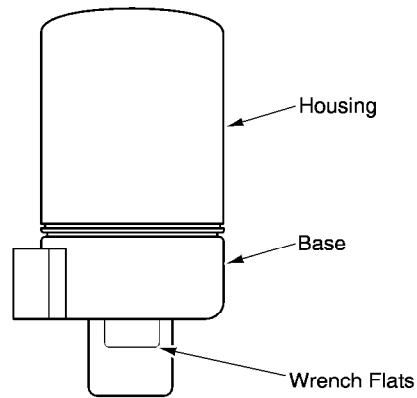

Figure-3 Housing and Base Location.

## Dampers

The actuator is not position sensitive. It can be mounted in any position in an NEMA Type 1 location.

## Valves

Allow 3" (76 mm) of clearance above the actuator valve assembly for the removal and reattachment of the actuator to the installed valve.

1. Install all two-way valves so that they close against the flow. An arrow on the valve body or tag indicates proper flow direction.
2. Always install three-way mixing valves with two inlets and one outlet.
3. Always install three-way diverting valves with one inlet and two outlets.

---

**Caution:** For steam applications only, mount the actuator above the valve body at 45° from vertical.

---

4. Actuators can be mounted in any upright position above the centerline of the valve body.

## Wiring Requirements

### Control Leads

The control leads may be connected to a Class 2 circuit if routed separately from Class 1 circuit wiring. Refer to Figure-8.

Refer to Table-4 for the maximum wire run of the control leads.

---

**Caution:**

- Use three-conductor, twisted, shielded wire when it becomes necessary to install the control leads in the same conduit with power wiring or when RFI/EMI generating devices are near.
  - Do not connect the shield or conduit to earth ground.
- 

**Table-4 Control Wiring Data.**

Wire Size GA	Maximum Wire Run ft. (m)
18	1000 (304.8)
16	2250 (685.8)
14	4000 (1219.1)

### Power Leads

The low voltage (24 Vac) power leads may be connected to a Class 2 circuit if routed separately from Class 1 circuit wiring. Refer to Figure-8. Line voltage power leads must be connected to a Class 1 circuit.

Refer to Table-5 for maximum length of run for given wire size(s). To determine the allowable maximum power lead run for multiple actuator wiring, divide the maximum run shown in Table-5 by the number of actuators on the run.

**Table-5 Power Wiring Data.**

Actuator Voltage Vac	Actuator Model Number	Power Lead Colors	Wire Size GA	Maximum Wire Run ft. (m)
120	MP-5410 MP-5430	Black & White	14	3500 (1067)
240	MP-5411	Black & White/Black		6000 (1829)
24	MP-5413 MP-5433	Black & Black/Blue		300 (91.5)
24	MP-5413 MP-5433	Black & Black/Blue	12	480 (146.3)

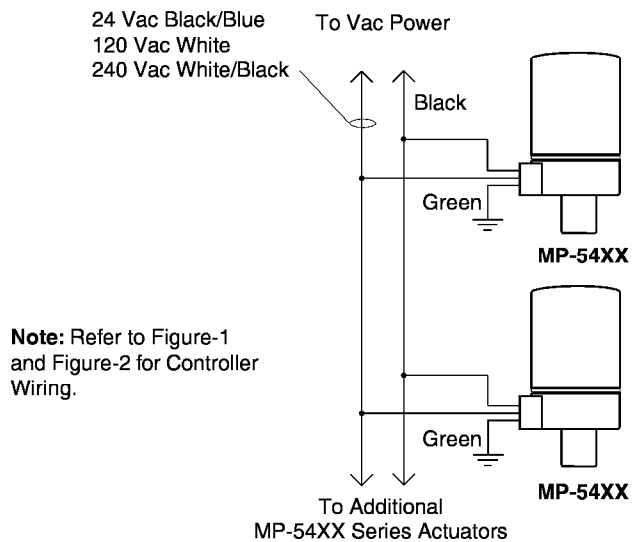

Figure-4 Wiring of Multiple MP-5400 Series Actuators to Single Power Source.

## Wiring Connections

### Wire Lead Connections (No Conduit)

Make connections as required. Refer to Figure-5.

---

*Note:* Cover plate and screw supplied with actuator are not required with this method.

---

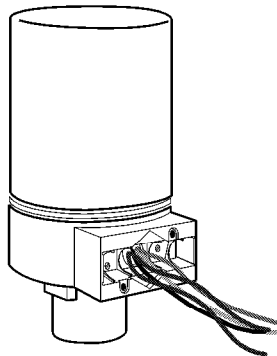

Figure-5 Wire Leads Connection (No Conduit).

### Installing 3/8" Flexible Conduit Onto One Or Both Sides Of Actuator

Flexible conduit may be installed onto one or both sides of the actuator (refer to Figure-7 and Figure-8). Install each conduit as follows:

1. Determine the side of the actuator to which the flexible conduit is to be attached.
2. Remove the knockout, using channel lock pliers, on the selected side of the actuator. Refer to Figure-6.

3. Make the required connections. Refer to Figure-1 or Figure-2 for a wiring diagram of your particular application.

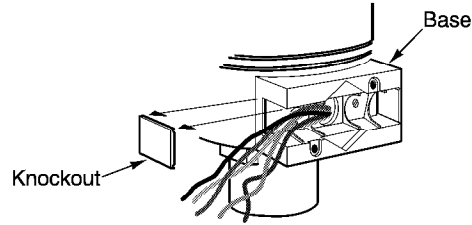

Figure-6 Removal of Knockout on Actuator Base.

4. Slip the conduit onto the base, over the ribs. Refer to Figure-7 and Figure-8.

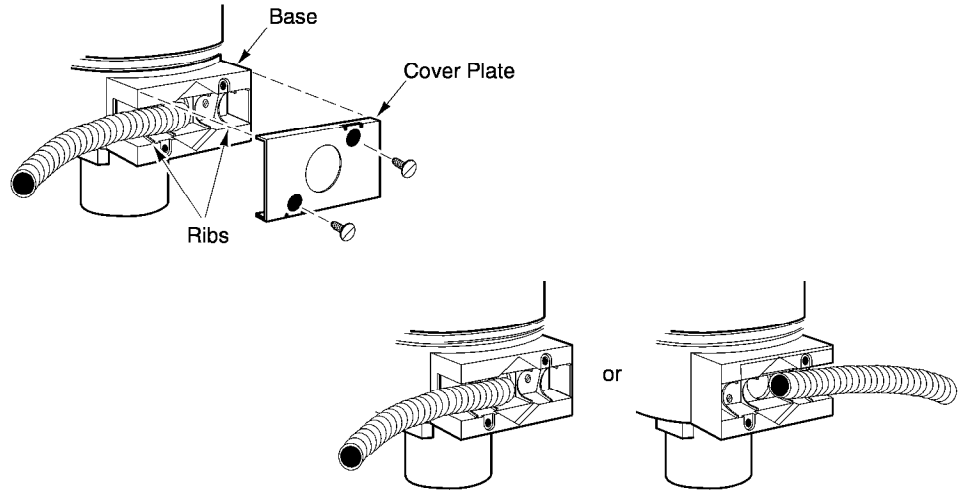

Figure-7 Flexible Conduit Installation to Either Side of Actuator.

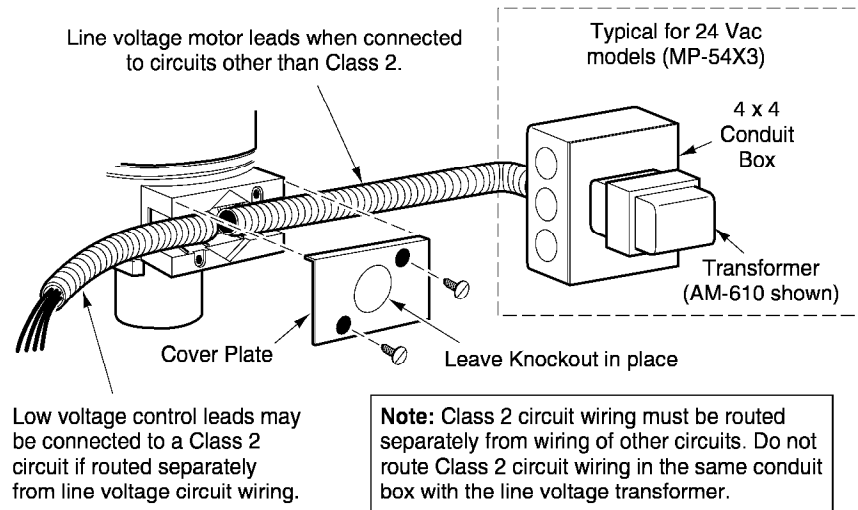

Figure-8 MP-5400 Series Wiring with Separation for Class 2 and Line Voltage Circuits.

5. Install the cover plate with two screws. The cover plate and two screws are supplied with the actuator.
6. If flexible conduit is to be installed on both sides of the actuator, repeat the preceding steps to install the second conduit.



## Installing Conduit Box Onto Actuator

Installation of a conduit box allows for the attachment of one or more thin wall conduits to the actuator. This procedure also serves as an optional method for connecting flexible conduit to the actuator.

1. Remove the knockout from the cover plate supplied with the actuator. Refer to Figure-9.

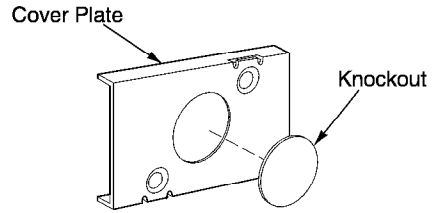

Figure-9 Cover Plate Knockout Removal.

2. Slip the actuator's leads through a standard 1/2" conduit bushing (Figure-10, not supplied) and the knockout hole in the cover plate. Refer to Figure-11.

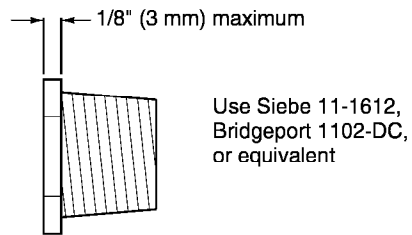

Figure-10 1/2" Conduit Bushing.

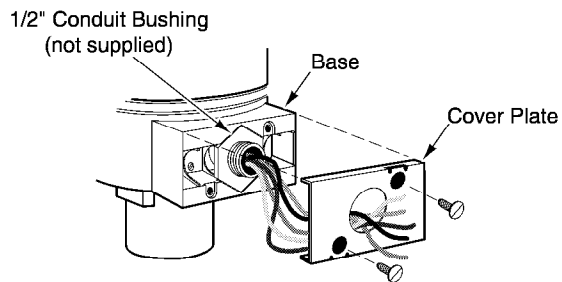

Figure-11 Conduit Bushing and Cover Plate Installation.

3. Seat the conduit bushing in the base.
4. Install the cover plate, using the two screws provided.

5. Loosely install the conduit box and the locknut onto the conduit bushing. Refer to Figure-12.

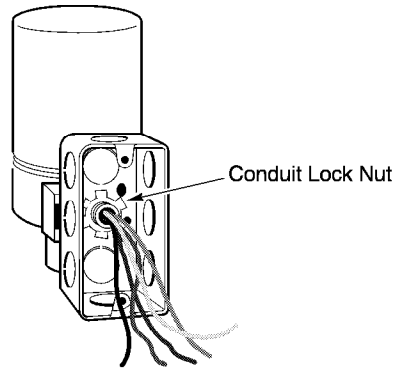

Figure-12 Attachment of Conduit Box to Threaded Adaptor.

6. Tighten the locknut as follows:
  - a. Tilt the conduit box approximately 30 degrees counterclockwise, relative to the actuator.
  - b. Finger-tighten the locknut against the conduit box.
  - c. Rotate the conduit box clockwise until it is aligned with the actuator. This will tighten the locknut.
7. Make the required wiring connections. Refer to Figure-1 and Figure-2 for typical control wiring diagrams.
8. Install the conduit to the conduit box as required.

---

*Note:* As shown in Figure-11, the hole in the actuator's cover plate is also sized to accept both British standard M20 (20 mm) conduit connectors and 20 mm-to-PG16 adaptors for use with DIN PG16 connectors. (Follow the steps for installing the conduit box to the actuator.)

---

## Linkage Assembly

### Damper

---

*Note:* Each actuator in the MP-543X series is provided with a factory-installed damper linkage. No separately-ordered linkage is required.

---

**Caution:** Do not twist or exert any force on the actuator housing during installation. Either turn the base by hand or, if necessary, use a 1-5/8" open-ended wrench (TOOL-37) on the flats provided on the actuator base, or on the valve body mounting nut. (Refer to Figure-3)

---

1. Determine the best mounting position for the actuator as follows:
  - a. Determine, from the system requirements, if the damper should spring-return to the open position (Figure-13) or closed position (Figure-14) whenever power is lost to the actuator. For example, an outside air damper actuator is typically linked so as to retract (spring-return) to the damper's fully closed position (safe position).
  - b. Be sure to allow adequate working space around the actuator mounting location to mount the actuator, link it to the damper, and wire it into the system (refer to Figure-18).
  - c. If possible, select a mounting position such that, at mid-stroke, the actuator crank arm and the damper crank arm on the drive shaft are each at a 90° angle to the damper rod (refer to Figure-15). This is the recommended mounting position. It may be necessary to swivel the actuator linkage to arrive at this mounting location.

- d. Consider the damper rod length when positioning the actuator in relation to the damper. A damper rod that is too long is not rigid enough to provide good control, while a damper rod that is too short makes adjustment difficult.

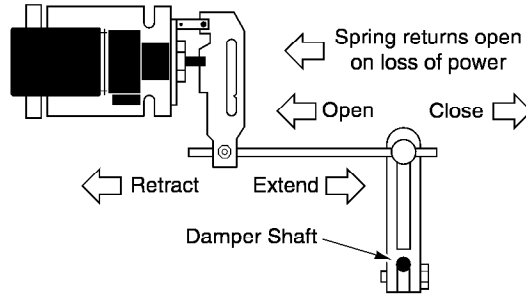

Figure-13 Dampers Open When Actuator Retracts (Spring>Returns Open on Power Loss).

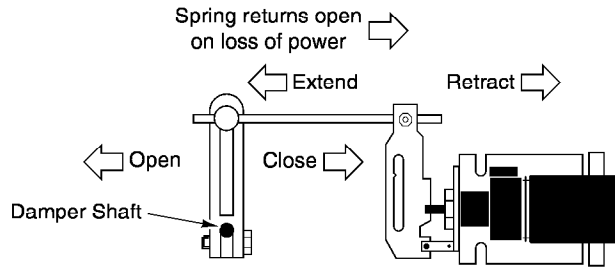

Figure-14 Dampers Open When Actuator Extends (Spring>Returns Closed on Power Loss).

- Position the actuator on the duct and mark the location of the mounting holes, using the actuator mounting bracket as a template (refer to Figure-18).
- Drill or punch the mounting holes in the duct for the appropriate 1/4" (6 mm) diameter screws or bolts. The actuator must be mounted firmly enough to prevent excessive actuator movement under normal damper loading. If there is excessive actuator movement, the damper may not fully open or close.

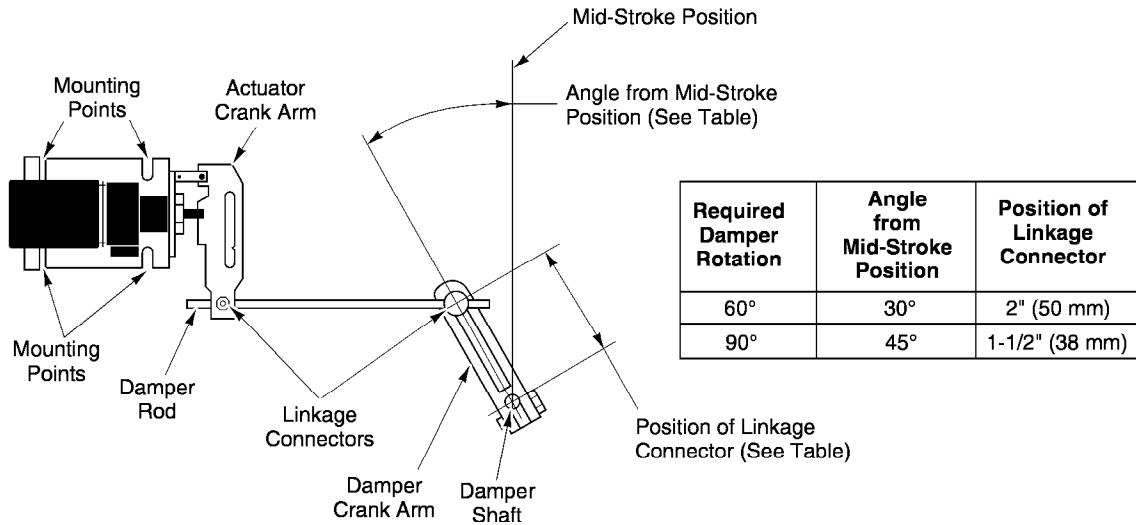

Figure-15 Actuator/Damper Mounting.

- Mount a ball joint connector in the slot on the damper crank arm. To achieve 90° of damper rotation, position the connector 1-1/2" (38 mm) from the centerline of the shaft hole on the crank arm. For 60° of damper rotation, position the connector 2" (50 mm) from the shaft hole centerline. Typically, 60° to 70° of rotation (maximum is 90°) is sufficient to permit almost maximum air flow through the dampers. Refer to Figure-15.

5. Rotate the damper to its open position. Install and secure the damper crank arm (with ball joint connector) to the damper shaft, positioning the crank arm as follows (refer to Figure-15):
  - a. To achieve 60° of damper rotation, position the crank arm so that it is pointed towards the actuator at 30° from its mid-stroke position.
  - b. To achieve 90° of damper rotation, position the crank arm so that it is pointed towards the actuator at 45° from its mid-stroke position.
6. Install the damper rod by sliding one end through the ball joint connector mounted on the damper crank arm, and the other end through the straight connector on the actuator crank arm. Tighten the nut on the actuator crank arm's straight connector. Cut off any excess length of damper rod.
7. For normally open dampers, tighten the nut on the ball joint connector on the damper crank arm. To ensure that the damper closes completely, make adjustments so that the actuator is 1/16" (1.6 mm) from the extended end of stroke when the damper closes. Verify and, if necessary, make final adjustments during system checkout.
8. For normally closed dampers, rotate the damper crank arm until the damper is closed. While holding the damper closed, tighten the nut on the ball joint connector on the damper crank arm. To ensure that the damper closes completely, make adjustments so that the actuator is 1/16" (1.6 mm) from the retracted end of stroke when the damper closes.

Final adjustment of the actuator and damper must be performed when the system is powered and functioning. Refer to the CHECKOUT section to ensure that the damper is linked correctly.

## Valve

For valve assembly details refer to **AV-600, Valve Linkage Kit General Instructions, F-26279** or **AV-601, Linkage Extension Kit General Instructions, F-26280**. Refer to Figure-19 for external dimensions of the valve actuator.

## Adjustments

### Start Point Adjustment

The start point of the actuators are factory-set at 6 Vdc and are field-adjustable, from 2 to 12 Vdc. If a start point other than 6 Vdc is required, proceed as follows:

1. Using a screwdriver, pry and remove the plug button from the base of the actuator, to expose the start point adjuster. Refer to Figure-16.
2. Disconnect the red, yellow, and blue actuator leads from the controller.
3. Connect the like-colored leads of TOOL-202 to the actuator leads.
4. Connect a DVM to the yellow lead (positive) and blue lead (negative) of the actuator.
5. Adjust TOOL-202 until the DVM reading equals the required start point voltage (2 to 12 Vdc).
6. Using a small, single-slotted screwdriver, adjust the actuator start point so that the actuator shaft just begins to extend.
7. Reinstall the plug button by pressing it into the base of the actuator.

8. The start point adjustment is complete.

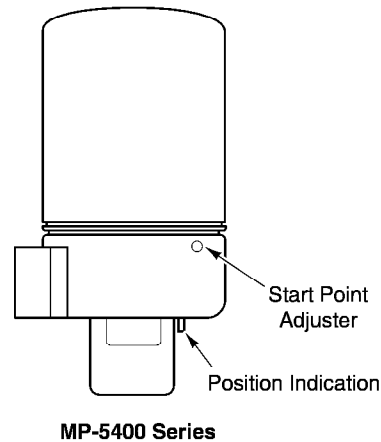

Figure-16 Start Point Adjuster for MP-5400 Series.

## CHECKOUT

After the entire system has been installed and the actuator has been powered up, perform the following checks for proper system operation.

---

**Caution:** Never power the actuator without a spring return linkage attached.

---

## Positioning with Controller

If the sensed media is within the controller's setpoint range, the actuator can be positioned by adjusting the controller setpoint up and down. Check for correct operation of the actuator (valve or damper) while the actuator is being stroked.

## Go, No-Go Test

1. Apply power to the actuator. The actuator motor should run and the actuator shaft should extend.
2. Remove power from the actuator. The actuator motor should stop running and the actuator shaft should spring-return to the retracted position.

## THEORY OF OPERATION

Refer to Figure-17. The permanently sealed, oil-filled case contains a movable hydraulic piston assembly and an electric pump/motor for the hydraulic system. The electric pump/motor is powered by the input supply voltage and runs continuously, generating a fluid pressure which is transmitted to the top of the piston. This fluid pressure creates a hydraulic force which drives the piston downward. Opposing the hydraulic force is the spring of the valve or damper linkage. When the hydraulic force becomes great enough to overcome the opposing spring force, the piston translates downward, extending the output shaft.

The pump/motor contains a transformer winding which provides power to the Vdc power supply. The power supply, in turn, provides power to the transducer assembly. To proportionally position the shaft, first the control signal (2 to 15 Vdc) input is compared to the shaft position feedback signal, through the actuator controller circuit. Then, the actuator controller circuit emits an output signal which positions the flapper in the transducer. The flapper opens or closes further to decrease or increase the hydraulic pressure above the piston, resulting in an upward or downward movement at the shaft.

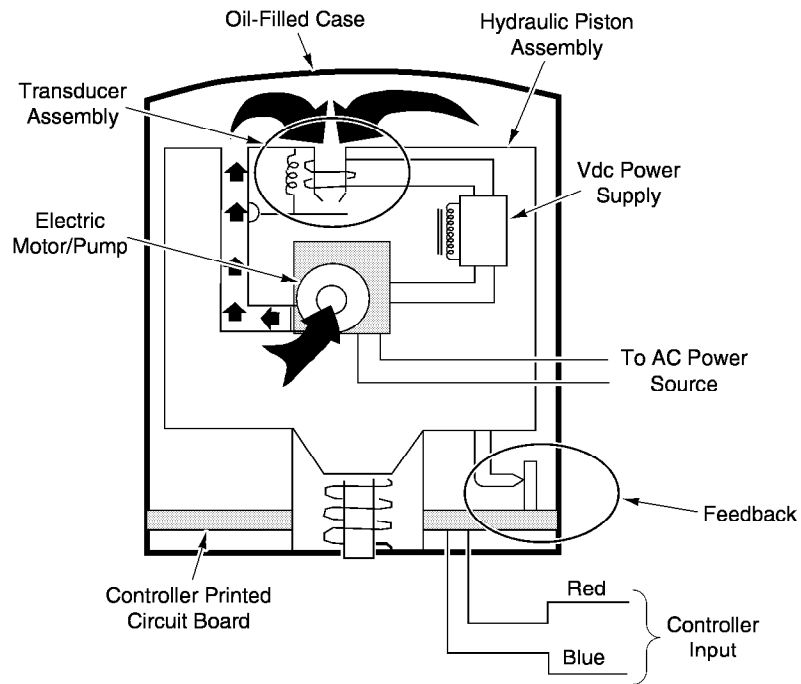

Figure-17 MP-5400 Series Actuators.

## MAINTENANCE

The actuator is sealed in oil and requires no maintenance.

Regular maintenance of the total system is recommended to assure sustained, optimum performance.

## TROUBLESHOOTING

Use the following steps to locate malfunctions:

1. Check the actuator by applying the proper supply voltage.
2. The motor should run when power is applied. If it does not run, the actuator is inoperative and should be replaced.
3. While the motor is running, the actuator should extend. If it does not extend, check the mechanical linkage for any damage or misadjustment which could prevent the actuator from extending. If the mechanical linkage is inoperative, adjust the linkage or replace the damaged components, as applicable. If the mechanical linkage moves correctly and freely, the problem lies in the actuator and it must be replaced.
4. If applying power directly to the actuator results in correct operation of the actuator, the actuator and linkage are functional, and the problem lies in the wiring or thermostat. Repair or replace the wiring or thermostat, as applicable.

## FIELD REPAIR

None. Replace an inoperative actuator with a functional unit.

# DIMENSIONAL DATA

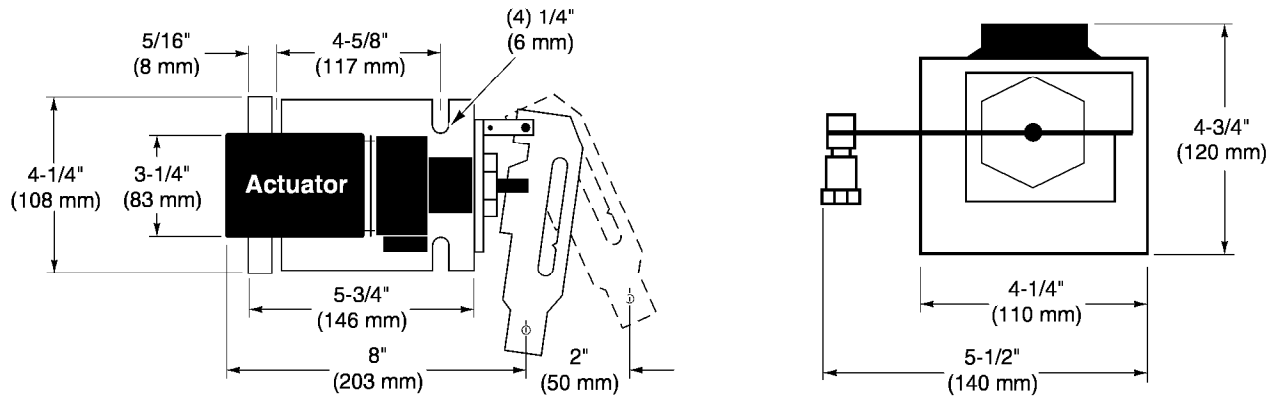

Figure-18 Damper Linkage Assembly Dimensions.

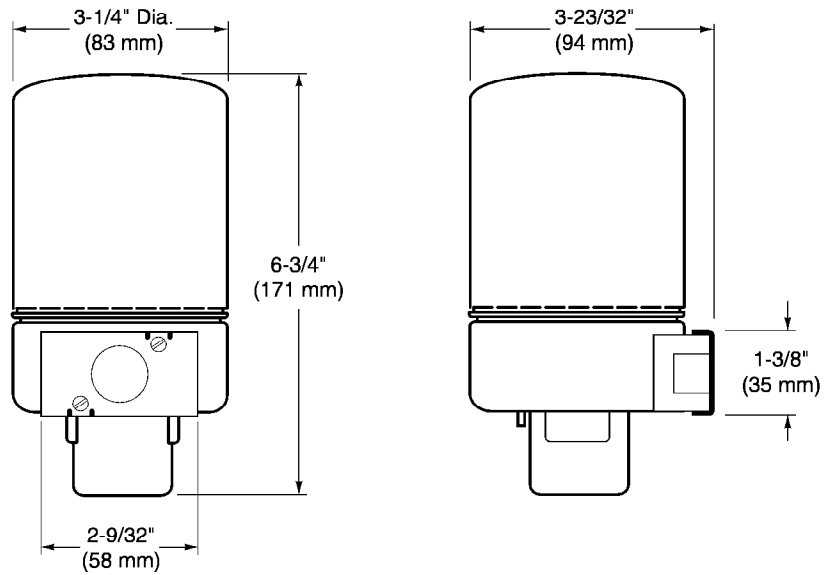

Figure-19 Actuator Dimensions.

NETWORK 8000 and MICROZONE II are registered trademarks, and System 8000 and LCM are trademarks, of Siebe Environmental Controls.