

Electronic Hydraulic Actuator General Instructions

Application

The MP-5200 Series actuators are for the electronic proportional control of dampers, valves, or program switches which require the return to normal position upon power interruption. This series is compatible with 2 to 15 Vdc input signals from System 8000™, NETWORK 8000®, and DMS DDC controllers.

Features

- Linear motion output shaft controlled by a variable dc voltage input signal.
- Spring return.
- Nominal 3 Vdc operating span.
- Fixed start point and non-positive positioning.
- 10,000 Ω or greater input impedance.
- 24 Vac, 120 Vac, and 240 Vac models
- Optional adjustable SPDT auxiliary switch.
- Available in damper models or base models that require damper or valve linkage.
- Die cast lower housing and painted steel upper housing.
- Hydraulic actuator with oil-immersed motor, transducer, and pump.
- Internal feedback circuitry provides non-positive positioning control in relation to the controller signal.

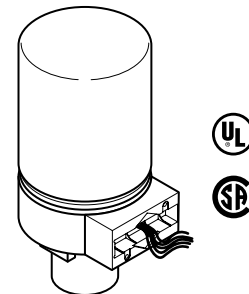

MP-521X
Valve Actuator

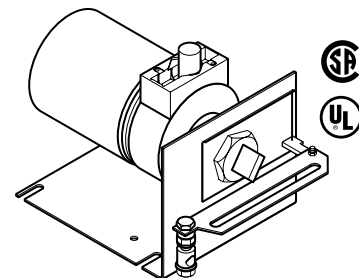

MP-523X
Damper Actuator

Applicable Literature

- Invensys Building Systems Cross-Reference Guide, F-23638
- Invensys Building Systems Reference Manual, F-21683
- Environmental Controls Application Manual, F-21335
- Invensys Building Systems Catalog, F-25683
- Engineering Bulletin EN-111, System 8000 Electronic Control, F-15264
- AV-600 Hydraulic Actuator Valve Linkage Kit, F-26279
- AV-601 Linkage Extension Set for AV-600 Valve Linkage Kit, F-26280
- AV-7600-1 Hydraulic Actuator Valve Linkage Kit, F-26235

SPECIFICATIONS

Actuator Inputs

Compatible with: 2 to 15 Vdc from System 8000, NETWORK 8000, or DMS controllers.
Operating Span, Nominally 3 Vdc fixed. 4.5 to 12 Vdc are required to assure full stroke travel under various loading conditions.
Nominal Extended Start Point, Approximately 6 Vdc.
Signal Impedance, 10,000 Ω or greater.
Power Input: Refer to Table-1 and Table-2. All 24 Vac circuits are Class 2.
Connections: Color-coded 4' (1.2 m) leads.

Actuator Outputs

Electrical:

Internal Power Supply, 20 Vdc, 25 mA.
Auxiliary Switch (-500 models), 10 Amps, 120/240 Vac adjustable SPDT, factory set to close the N.C. contact at the retracted end of stroke.

Mechanical:

Stroke,

Damper 2" (51 mm) over a nominal 6 Vdc (fully retracted) to 9 Vdc (fully extended) input range (includes AM-601 linkage).
Valve 9/16" (14.3 mm) over a nominal 6 Vdc (fully retracted) to 9 Vdc (fully extended) input range.

Torque, Refer to Table-1 and Table-2.

Nominal Damper Area: Actuator selection should be made in accordance with damper manufacturer's specifications.

Environment

Ambient Temperature Limits:

Shipping & Storage, -40 to 160° F (-40 to 71° C).
Operating, -20 to 140° F (-29 to 60° C).
Damper -20 to 140° F (-29 to 60° C).
Valve Refer to Table-3.

Humidity: 5 to 95% RH, non-condensing.

Location: NEMA Type 1.

Agency Listings

UL 873: Underwriters Laboratories (File # E9429 Category Temperature-Indicating and Regulating Equipment).

CSA: Certified for use in Canada by Underwriters Laboratories. Canadian Standard C22.2 No. 24-93.

European Community: EMC Directive (89/336/EEC). Low Voltage Directive (72/23/EEC).

Table-1 Model Chart for Damper Actuators.

Part Number	Actuator Power Input					10 Amps ^a Aux Switch	Timing in Seconds @ 72° F (22° C)			Torque Rating (Extend & Retract) lb. - in. (N-m)
	Voltage $\pm 10\%$	60 Hz		50 Hz			No Load Stroke		Retract on Power Loss	
		Watts	Amps	Watts	Amps		To Extend	To Retract		
MP-5230	120	11.7	0.16	12.9	0.19	No	60	40	15	1.86 (0.21)
MP-5233	24	12.0	0.80	13.2	0.97	No				

^a Common of switch is in series with AC power supply to the motor. Therefore, the switch must be wired to control the same voltage as the actuator itself.

Table-2 Model Chart for Valve Actuators. Also for Damper Actuators with Field Assembled Damper Linkages.

Part Number	Actuator Power Input					10 Amps ^a Aux Switch	Timing in Seconds @ 72° F (22° C)			Required Linkage	
	AC Voltage ± 10%	60 Hz		50 HZ			No Load Stroke		Retract on Power Loss	Damper	Valve
		Watts	Amps	Watts	Amps		To Extend	To Retract			
MP-5210	120	11.7	0.16	12.9	0.19	No	60	40	15	AM-601 ^b	AV-7600-1 AV-601 ^c
MP-5210-500						Yes					
MP-5211	240	11.8	0.08	13.0	0.09	No					
MP-5211-500						Yes					
MP-5213	24	12.0	0.80	13.2	0.97	No					
MP-5213-500						Yes					

- ^a Common of switch is in series with AC power supply to the motor. Therefore, the switch must be wired to control the same voltage as the actuator itself.
- ^b With the installation of the AM-601 damper linkage, these valve actuators become functionally the same as the damper actuators listed in Table-1. Refer to Table-1 for the torque rating.
- ^c AV-601 required for steam applications, recommended for hot water applications and in chilled water applications where condensation may occur on actuator.

Table-3 Maximum Allowable Ambient Air Temperature for Valve Actuators.

Temperature of Media in the Valve Body (Check the Rating of the Valve) °F (°C)	Maximum Allowable Ambient Air Temperature of MP-52XX Series	
	AV-600 Only for Chilled Water Applications °F (°C)	AV-600 with AV-601 extension °F (°C)
366 (180)	90 (32)	90 (32)
340 (171)	100 (38)	100 (38)
281 (138)	115 (46)	140 (60)
181 (83)	140 (60)	140 (60)
80 (26)	140 (60)	140 (60)

ACCESSORIES

Common

- 11-1612 1/2" conduit bushing.
- AD-8969-612 Capacitor kit For MP-52XX-XXX-0-3 and earlier models only. Capacitor built into MP-52XX-XXX-0-4 and later models.

Damper Only

- AD-553 Sequencing adaptor.
- AE-249 Transformer.
- AM-111 Crank arm for 5/16" diameter damper shaft.
- AM-112 Crank arm for 3/8" diameter damper shaft.
- AM-113 Crank arm for 1/2" diameter damper shaft.
- AM-115 Crank arm for 7/16" diameter damper shaft.
- AM-122 Linkage connector straight type.
- AM-123 Damper clip.
- AM-125 5/16" diameter x 20" damper rod.
- AM-125-048 5/16" diameter x 48" damper rod.
- AM-132 Ball joint connector.
- AM-161-3 Damper linkage kit.
- AM-601 Device includes mounting bracket, damper linkage with spring, and AM-122 straight connector. Required to modify (MP-521X series) valve actuators into 2" (51 mm) stroke damper actuators.
- AM-602 Spacer.

Valve Only

- AV-600 Valve linkage.
- AV-601 Valve linkage extension for hot water and steam applications; use with AV-600 (may be used on chilled water to avoid condensation).

TOOLS (factory available)

- TOOL-12 Wrench for adjustment of auxiliary switch.
- TOOL-19 Spring compression tool for AV-600.
- TOOL-37 1-5/8" open-end wrench.
- TOOL-202 Manual positioner.

TYPICAL APPLICATIONS (wiring diagrams)

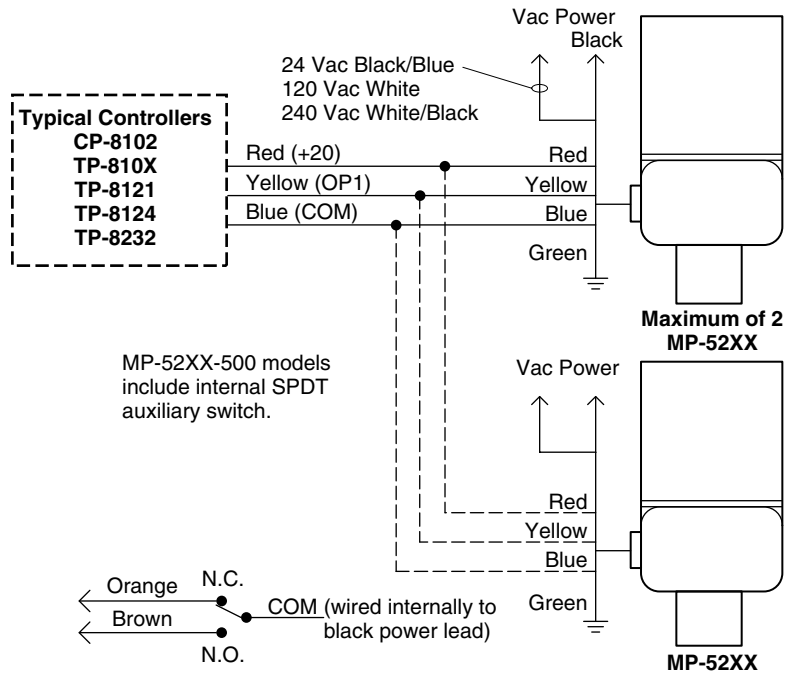

Figure-1 Typical Control Wiring for Up to Two MP-5200 Series Actuators to Controllers Requiring External 20 Vdc Power Supply.

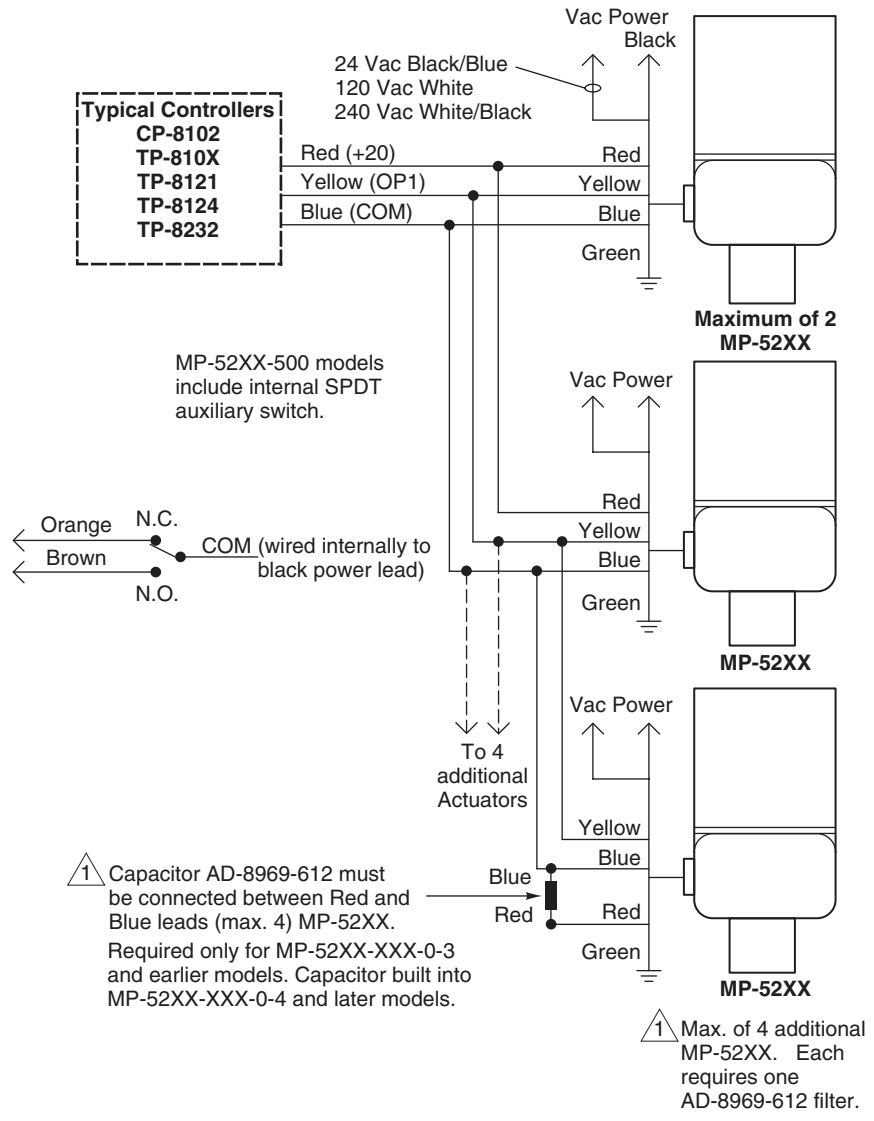

Figure-2 Typical Control Wiring for More Than Two MP-5200 Series Actuators to Controller Requiring External 20 Vdc Power from the Actuator.

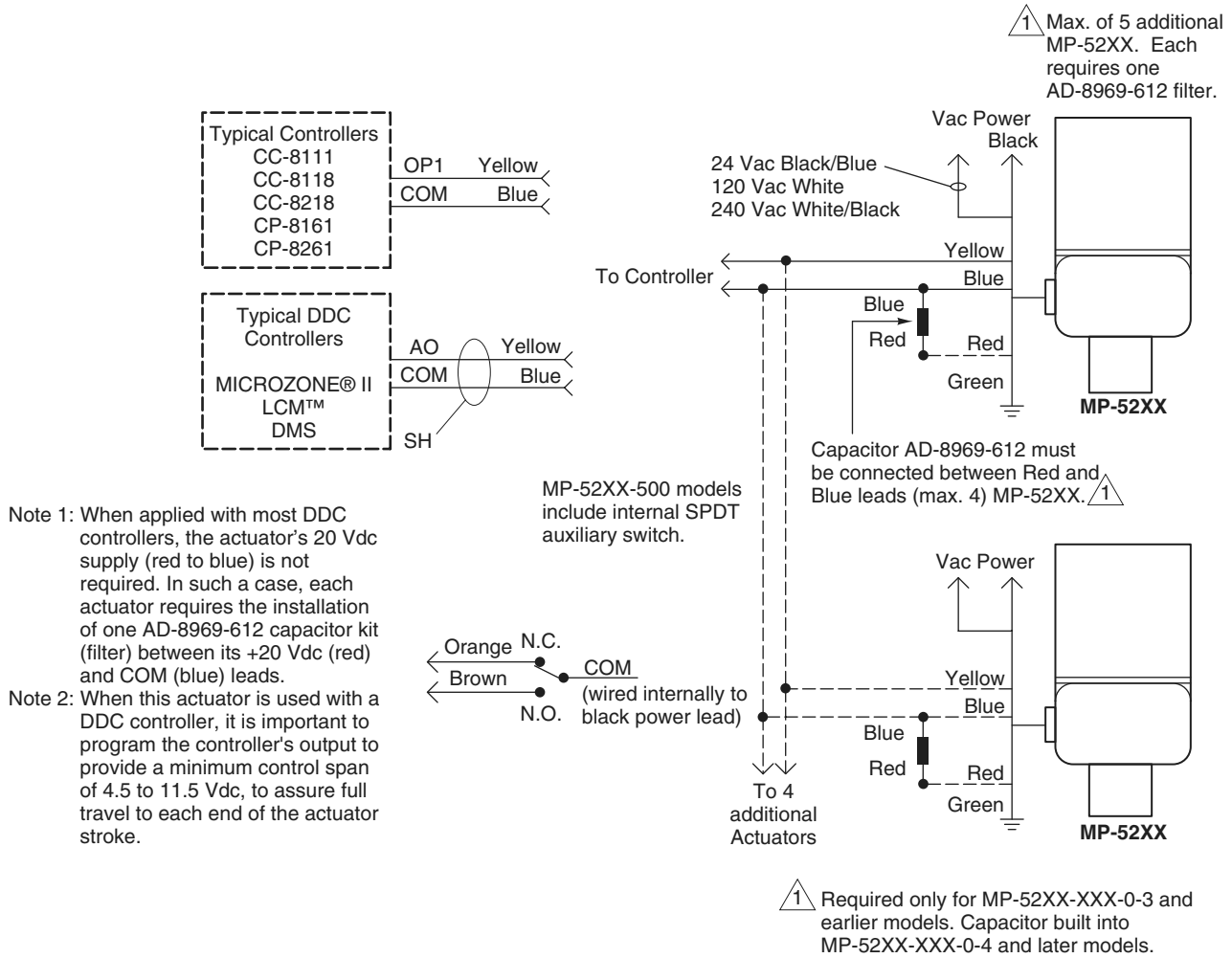

Figure-3 Typical Control Wiring For Up to Six MP-5200 Series Actuators to Controllers That Do Not Require 20 Vdc Power From the Actuator.

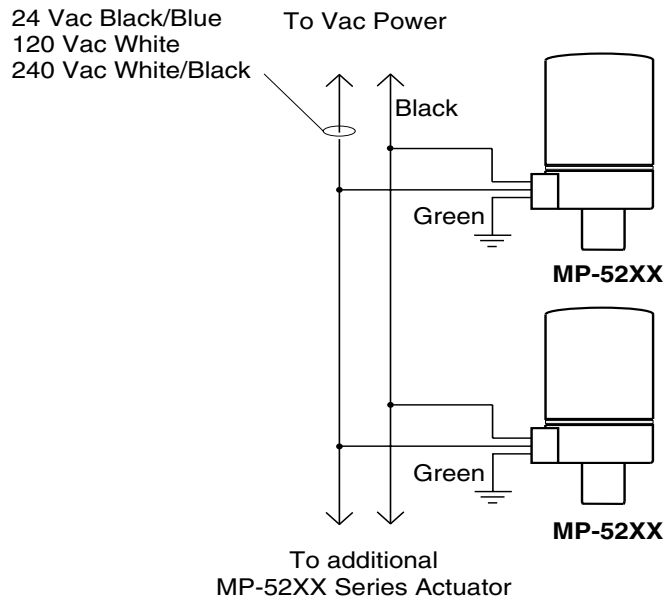

Figure-4 Wiring of Multiple MP-5200 Series Actuators to Single Power Source.

INSTALLATION

Inspection

Inspect the package for damage. If damaged, notify the appropriate carrier immediately. If undamaged, open the package and inspect the device for obvious damage. Return damaged products.

Requirements

- Job wiring diagrams
- Tools (not provided):
 - Digital Volt-ohm Meter (DVM)
 - Appropriate drill and drill bit for mounting screws on dampers
 - Appropriate screw drivers and wrenches
 - TOOL-12, Wrench for adjustment of auxiliary switch
 - TOOL-19, Spring compression tool for AV-600 when used on VB-9XXX valves only
 - TOOL-37, 1-5/8" open-ended wrench
- Training: Installer must be a qualified, experienced technician



Warning:

- Disconnect power at breaker or fuse before installation to prevent electrical shock and equipment damage.
 - Make all connections in accordance with the wiring diagram and in accordance with national and local electrical codes. *Use copper conductors only.*
-

Caution:

- Static charges produce voltages high enough to damage the electronic components. Follow static electricity precautions when installing or servicing the device(s). Discharge any static electricity you may have accumulated by using wrist straps, or by touching a known, securely grounded object.
 - Do not exceed the ratings of the device(s).
 - Do not apply power to the unit unless the damper linkage and/or the valve assembly have been installed.
 - Avoid locations where excessive moisture, corrosive fumes, or vibration is present.
 - Do not install insulation on any part of the actuator.
-

Mounting

Caution: Do not twist or exert any force on the actuator housing during installation. Either turn the base by hand or, if necessary, use a 1-5/8" open-ended wrench (TOOL-37) on the flats provided on the actuator base or the valve body mounting nut. Refer to Figure-5.

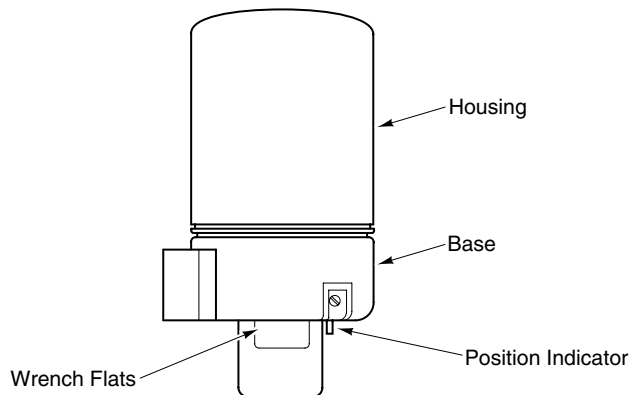

Figure-5 Housing and Base Location.

Dampers

The actuator is not position sensitive. It can be mounted in any position in a NEMA Type 1 location.

Valves

Allow 3" (76 mm) of clearance above the actuator valve assembly for the removal and reattachment of the actuator to the installed valve.

1. Install all two-way valves so that they close against the flow. An arrow on the valve body or tag indicates proper flow direction.
2. Always install three-way mixing valves with two inlets and one outlet.
3. Always install three-way diverting valves with one inlet and two outlets.
4. Actuators can be mounted in any upright position to approximately 5° above the centerline of the valve body.

Caution: For steam applications only, mount the actuator above the valve body at approximately 45° from vertical for maximum heat dissipation.

Wiring Requirements

Control Leads

The control leads may be connected to a Class 2 circuit if routed separately from Class 1 circuit wiring. Refer to Figure-9.

Refer to Table-4 for the maximum wire run of the control leads.

Caution:

- Use three-conductor, twisted, shielded wire when it becomes necessary to install the control leads in the same conduit with power wiring or when RFI/EMI generating devices are near.
- Do not connect the shield or conduit to earth ground.

Table-4 Control Wiring Data.

Wire Size GA	Maximum Wire Run ft. (m)
18	1000 (304.8)
16	2250 (685.8)
14	4000 (1219.1)

Power Leads

The low voltage (24 Vac) power leads may be connected to a Class 2 circuit if routed separately from Class 1 circuit wiring. Refer to Figure-9. Line voltage power leads must be connected to a Class 1 circuit.

Refer to Table-5 for maximum length of run for given wire size(s). To determine the allowable maximum power lead run for multiple actuator wiring, divide the maximum run shown in Table-5 by the number of actuators on the run.

Table-5 Power Wiring Data.

Actuator Voltage Vac	Actuator Model Number	Power Lead Colors	Wire Size GA	Maximum Wire Run ft. (m)		
120	MP-52X0	Black & White	14	3500 (1067)		
	MP-5210-500					
240	MP-52X1	Black & White/Black		14	6000 (1829)	
	MP-5211-500					
24	MP-52X3	Black & Black/Blue			14	300 (91.5)
	MP-5213-500					
24	MP-52X3	Black & Black/Blue	12			480 (146.3)
	MP-5213-500					

Wiring Connections

Wire Lead Connections (No Conduit)

Make connections as required. Refer to Figure-6.

Note: Cover plate and screw supplied with actuator are not required with this method.

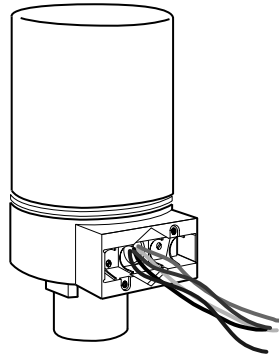

Figure-6 Wire Leads Connection (No Conduit).

Installing 3/8" Flexible Conduit onto One or Both Sides of Actuator

Flexible conduit may be installed onto one or both sides of the actuator (refer to Figure-8 and Figure-9). Install each conduit as follows:

1. Determine the side of the actuator to which the flexible conduit is to be attached.
2. Remove the knockout, using channel lock pliers, on the selected side of the actuator. Refer to Figure-7.
3. Make the required connections. Refer to Figure-1, Figure-2, or Figure-3 for a wiring diagram similar to your particular application.

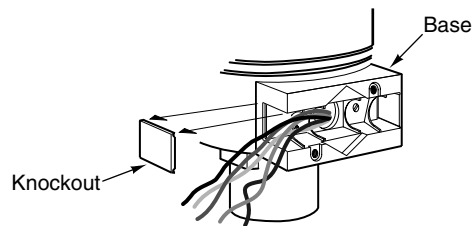

Figure-7 Removal of Knockout on Actuator Base.

4. Slip the conduit onto the base, over the ribs. Refer to Figure-8 and Figure-9.

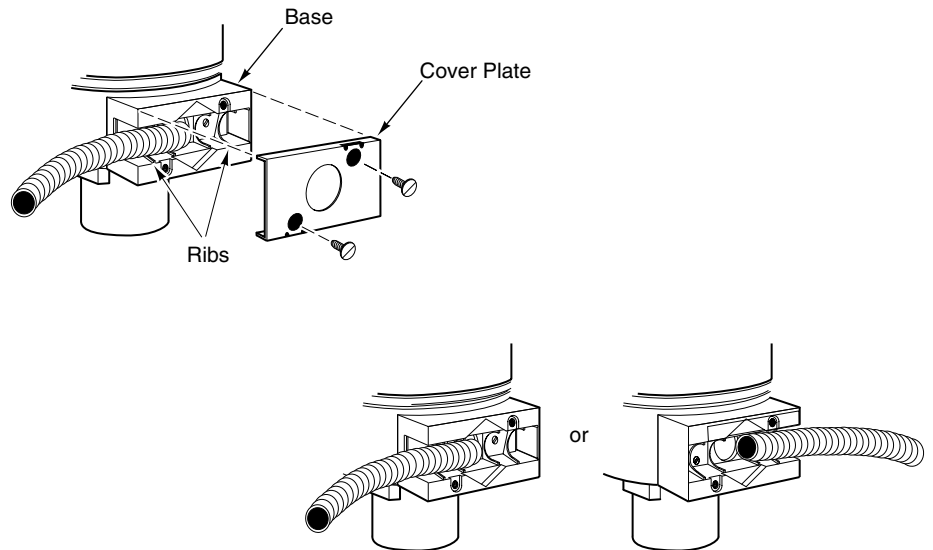

Figure-8 Flexible Conduit Installation to Either Side of Actuator.

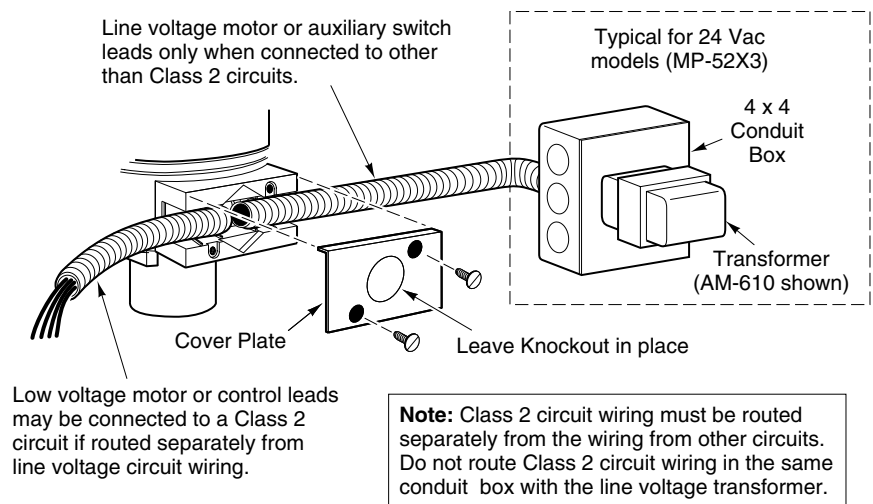

Figure-9 MP-5200 Series Wiring with Separation for Line Voltage and Class 2 Circuits.

5. Install the cover plate with two screws. The cover plate and two screws are supplied with the actuator.
6. If flexible conduit is to be installed on both sides of the actuator, repeat the preceding steps to install the second conduit.

Auxiliary Switch Leads

The low voltage (24 Vac) auxiliary switch leads may be connected to a Class 2 circuit. The line voltage (120 Vac and 240 Vac) auxiliary switch leads must be connected to a Class 1 circuit and routed separately from any Class 2 circuit wiring. Refer to Figure-4.

Installing Conduit Box Onto Actuator

Installation of a conduit box allows for the attachment of one or more thin wall conduits to the actuator. This procedure also serves as an optional method for connecting flexible conduit to the actuator.

1. Remove the knockout from the cover plate supplied with the actuator. Refer to Figure-10.

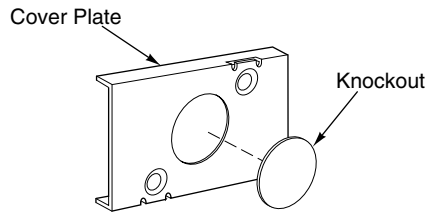

Figure-10 Cover Plate Knockout Removal.

2. Slip the actuator's leads through a standard 1/2" conduit bushing (Figure-11, not supplied) and the knockout hole in the cover plate. Refer to Figure-12.

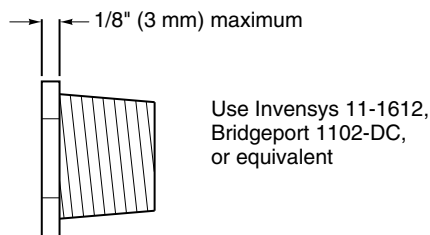

Figure-11 1/2" Conduit Bushing.

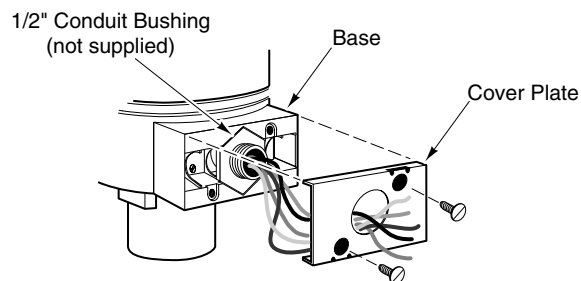

Figure-12 Conduit Bushing and Cover Plate Installation.

3. Seat the conduit bushing in the base.
4. Install the cover plate, using the two screws provided.
5. Loosely install the conduit box and the locknut onto the conduit bushing. Refer to Figure-13.

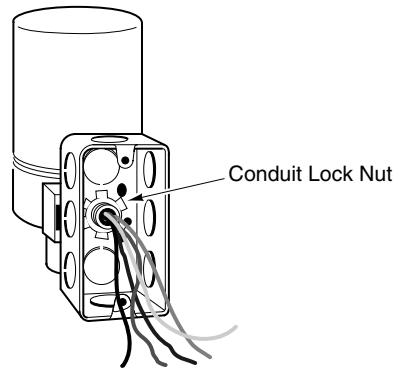

Figure-13 Attachment of Conduit Box to Conduit Bushing.

6. Tighten the locknut as follows:
 - a. Tilt the conduit box approximately 30 degrees counterclockwise, relative to the actuator.
 - b. Finger-tighten the locknut against the conduit box.
 - c. Rotate the conduit box clockwise until it is aligned with the actuator. This will tighten the locknut.
7. Make the required wiring connections. Refer to Figure-1, Figure-2, and Figure-3 for typical control wiring diagrams.
8. Install the conduit to the conduit box as required.

Note: As shown in Figure-12, the hole in the actuator's cover plate is also sized to accept both British standard M20 (20 mm) conduit connectors and 20 mm-to-PG16 adaptors for use with DIN PG16 connectors. (Follow the steps for installing the conduit box to the actuator.)

Linkage Assembly

Damper

Note: Each actuator in the MP-523X Series is provided with a factory-installed damper linkage. No separately-ordered linkage is required.

Do not twist or exert any force on the actuator housing during installation. Either turn the base by hand or, if necessary, use a 1-5/8" open-ended wrench (TOOL-37) on the flats provided on the actuator base, or on the valve body mounting nut. Refer to Figure-5.

1. Determine the best mounting position for the actuator as follows:
 - a. Determine, from the system requirements, if the damper should spring-return to the open position (Figure-14) or closed position (Figure-15) whenever power is lost to the actuator. For example, an outside air damper actuator is typically linked so as to retract (spring-return) to the damper's fully closed position (safe position).
 - b. Be sure to allow adequate working space around the actuator mounting location to mount the actuator, link it to the damper, and wire it into the system (refer to Figure-21).
 - c. If possible, select a mounting position such that, at mid-stroke, the actuator crank arm and the damper crank arm on the drive shaft are each at a 90° angle to the damper rod (refer to Figure-16). This is the recommended mounting position. It may be necessary to swivel the actuator linkage to arrive at this mounting location.
 - d. Consider the damper rod length when positioning the actuator in relation to the damper. A damper rod that is too long is not rigid enough to provide good control, while a damper rod that is too short makes adjustment difficult.

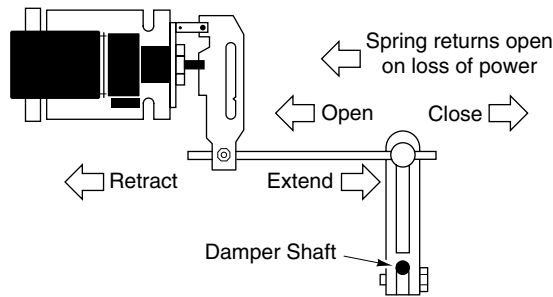

Figure-14 Dampers Open When Actuator Retracts (Spring-Returns Open on Power Loss).

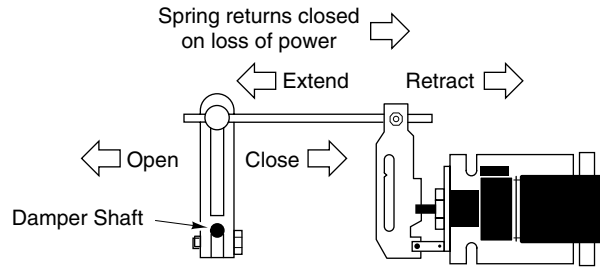

Figure-15 Dampers Open When Actuator Extends (Spring-Returns Closed on Power Loss).

2. Position the actuator on the duct and mark the location of the mounting holes, using the actuator mounting bracket as a template (refer to Figure-21).
3. Drill or punch the mounting holes in the duct for the appropriate 1/4" (6 mm) diameter screws or bolts. The actuator must be mounted firmly enough to prevent excessive actuator movement under normal damper loading. If there is excessive actuator movement, the damper may not fully open or close.

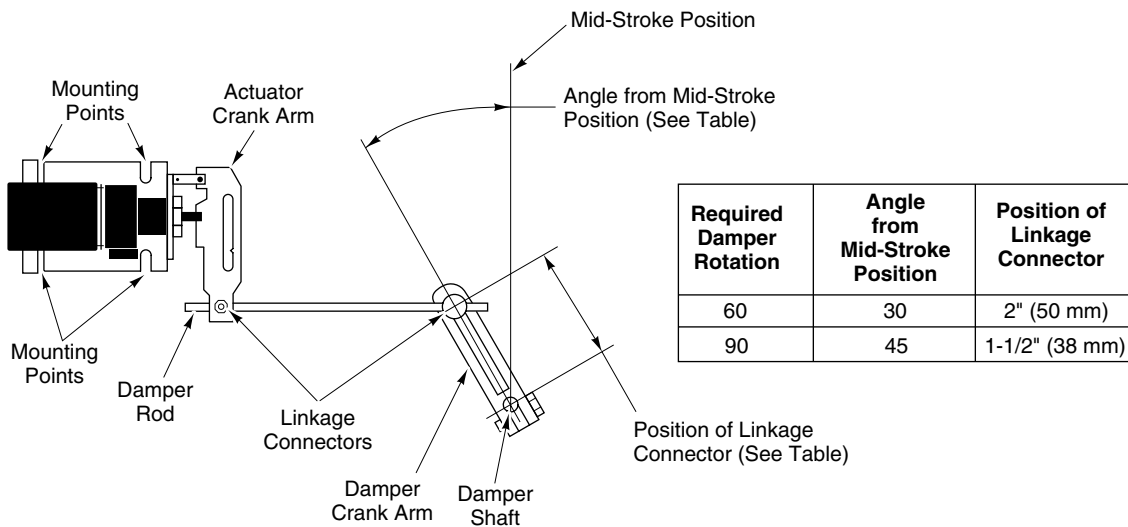

Figure-16 Actuator/Damper Mounting.

4. Mount a ball joint connector in the slot on the damper crank arm. To achieve 90° of damper rotation, position the connector 1-1/2" (38 mm) from the centerline of the shaft hole on the crank arm. For 60° of damper rotation, position the connector 2" (50 mm) from the shaft hole centerline. Typically, 60° to 70° of rotation (maximum is 90°) is sufficient to permit almost maximum air flow through the dampers. Refer to Figure-16.

5. Rotate the damper to its open position. Install and secure the damper crank arm (with ball joint connector) to the damper shaft, positioning the crank arm as follows (refer to Figure-16):
 - a. To achieve 60° of damper rotation, position the crank arm so that it is pointed towards the actuator at 30° from its mid-stroke position.
 - b. To achieve 90° of damper rotation, position the crank arm so that it is pointed towards the actuator at 45° from its mid-stroke position.
6. Install the damper rod by sliding one end through the ball joint connector mounted on the damper crank arm, and the other end through the straight connector on the actuator crank arm. Tighten the nut on the actuator crank arm's straight connector. Cut off any excess length of damper rod.
7. For normally open dampers, tighten the nut on the ball joint connector on the damper crank arm. To ensure that the damper closes completely, make adjustments so that the actuator is 1/16" (1.6 mm) from the extended end of stroke when the damper closes. Verify and, if necessary, make final adjustments during system checkout.
8. For normally closed dampers, rotate the damper crank arm until the damper is closed. While holding the damper closed, tighten the nut on the ball joint connector on the damper crank arm. To ensure that the damper closes completely, make adjustments so that the actuator is 1/16" (1.6 mm) from the retracted end of stroke when the damper closes.

Final adjustment of the actuator and damper must be performed when the system is powered and functioning. Refer to the CHECKOUT section to ensure that the damper is linked correctly.

Valve

For valve assembly details refer to *AV-600, Valve Linkage Kit General Instructions, F-26279* for VB-9XXX valves, or *AV-7600-1, Valve Linkage Kit General Instructions, F-26235* for VB-7XXX valves, with *AV-601, Linkage Extension Kit General Instructions, F-26280*. Refer to Figure-22 for external dimensions of the valve actuator.

Adjustments

Auxiliary Switch (MP-52XX-500)

The switching point is adjustable over the entire actuator stroke and is pre-set at the factory to close the N.C. contacts at the retracted end of stroke. Turning the switch adjustment screw CW (using TOOL-12), adjusts the make (or break) point closer to the extended end of stroke. Refer to Figure-17.

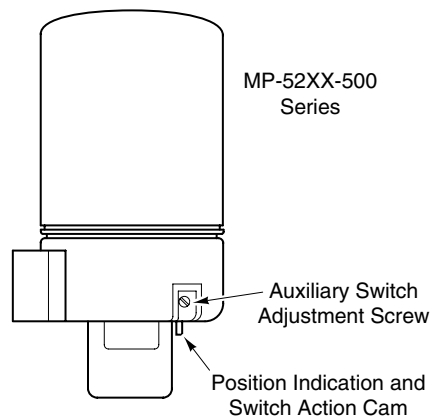

Figure-17 Auxiliary Switch Point Adjustment and Position Indication for MP-5200 Series.

CHECKOUT

After the entire system has been installed and the actuator has been powered up, perform the following checks for proper system operation.

Caution: Never power the actuator without a spring return linkage attached.

Go, No-Go Test

1. If actuator is MP-52XX-XXX-0-3 or older model, install the AD-8969-612 filter capacitor (not required for MP-52XX-XXX-0-4 or newer models).
2. The actuator should be powered.
3. Disconnect the control leads from the controller.
4. To make the actuator shaft extend fully, short the red lead to the yellow lead.
5. To make the actuator retract fully, short the blue lead to the yellow lead.
6. Check for proper operation of the valve or damper as the actuator is operated.
7. Reconnect the control wiring.

Positioning with Controller

If the sensed media is within the controller's setpoint range, the actuator can be positioned by adjusting the controller setpoint up and down. Check for correct operation of the actuator (valve or damper) while the actuator is being stroked.

THEORY OF OPERATION

Refer to Figure-18. The permanently sealed, oil-filled case contains a movable hydraulic piston assembly and an electric pump/motor for the hydraulic system. The electric pump/motor is powered by the input supply voltage and runs continuously, generating a fluid pressure which is transmitted to the top of the piston. This fluid pressure creates a hydraulic force which drives the piston downward. Opposing the hydraulic force is the spring of the valve or damper linkage. When the hydraulic force becomes great enough to overcome the opposing spring force, the piston translates downward, extending the output shaft.

The pump/motor contains a transformer winding which provides power to the Vdc power supply. The power supply, in turn, provides power to the transducer assembly. To proportionally position the shaft, first the control signal (2 to 15 Vdc) input is compared to the shaft position feedback signal, through the actuator controller circuit. Then, the actuator controller circuit emits an output signal which positions the flapper in the transducer. The flapper opens or closes further to decrease or increase the hydraulic pressure above the piston, resulting in an upward or downward movement at the shaft.

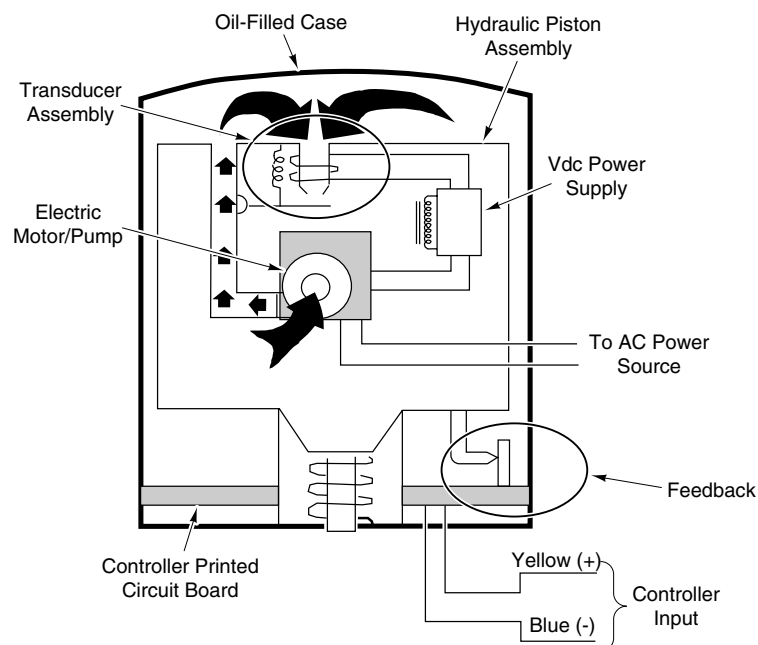

Figure-18 MP-5200 Series Actuators.

REPLACEMENT PARTS

The installation of replacement actuators, in place of the obsolete series of MP-52XX actuators, may require additional items. These replacement items are required for the following reasons:

1. The AM-601 damper linkage is used to convert base actuators to damper actuators when damper models are not available. Refer to Figure-20.
2. The AM-602 spacer is used when current actuators are installed on old linkages. Refer to Figure-19.
3. The AE-249 transformer (208 Vac to 120 Vac) is used when replacing 208 Vac actuators with 120 Vac actuators.
4. Resistors are required when an obsolete TP-5XXX or CP-51XX controller is used to control a current actuator. Detailed resistor and wiring information is provided in section C1.1 of *Engineering Bulletin EN-111 (System 8000 Electronic Control)*, F-15264.

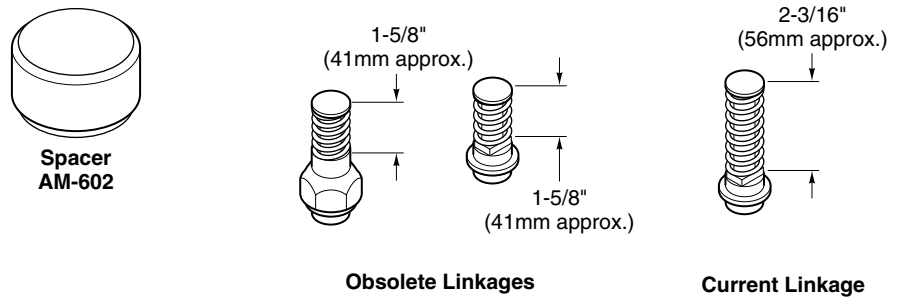

Figure-19 Current or Obsolete Valve Linkage.

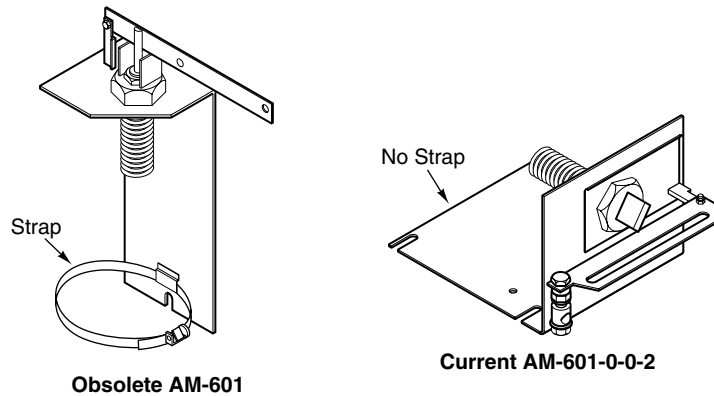

Figure-20 Current or Obsolete Damper Linkage.

Table-6 Cross Reference of Obsolete Series of MP-5200 Actuators.

Actuator Being Replaced	Replacement Actuator	Other Replacement Items Required			
		AM-601-0-0-2 Current Damper Linkage	AM-602 Spacer	AE-249 ^a Transformer	Resistor ^b
MP-5210	MP-5210-0-0-3	No	Yes	No	Yes
MP-5210-0-0-1	MP-5210-0-0-3	No	Yes	No	Yes
MP-5210-0-0-2	MP-5210-0-0-3	No	No	No	No
MP-5210-500	MP-5210-500-0-3	No	Yes	No	Yes
MP-5210-500-0-1	MP-5210-500-0-3	No	Yes	No	No
MP-5210-500-0-2	MP-5210-500-0-3	No	No	No	No
MP-5211	MP-5211-0-0-3	No	Yes	No	Yes
MP-5211-0-0-1	MP-5211-0-0-3	No	Yes	No	No
MP-5211-0-0-2	MP-5211-0-0-3	No	No	No	No
MP-5211-500	MP-5211-500-0-3	No	Yes	No	Yes
MP-5211-500-0-1	MP-5211-500-0-3	No	Yes	No	No
MP-5211-500-0-2	MP-5211-500-0-3	No	No	No	No
MP-5212	MP-5210-0-0-3	No	Yes	Yes	Yes
MP-5212-0-0-1	MP-5210-0-0-3	No	Yes	Yes	No
MP-5212-0-0-2	MP-5210-0-0-3	No	No	Yes	No
MP-5212-500	MP-5210-500-0-3	No	Yes	Yes	Yes
MP-5212-500-0-1	MP-5210-500-0-3	No	Yes	Yes	No
MP-5212-500-0-2	MP-5210-500-0-3	No	No	Yes	No
MP-5213	MP-5213-0-0-3	No	Yes	No	Yes
MP-5213-0-0-1	MP-5213-0-0-3	No	Yes	No	No
MP-5213-0-0-2	MP-5213-0-0-3	No	No	No	No
MP-5213-500	MP-5213-500-0-3	No	Yes	No	Yes
MP-5213-500-0-1	MP-5213-500-0-3	No	Yes	No	No
MP-5213-500-0-2	MP-5213-500-0-3	No	No	No	No
MP-5220	MP-5230-0-0-3	No	No	No	Yes
MP-5220-0-0-1	MP-5230-0-0-3	No	No	No	No
MP-5220-500	MP-5230-0-0-3	Yes	No	No	Yes
MP-5220-500-0-1	MP-5230-500-0-3	Yes	No	No	No
MP-5221	MP-5211-0-0-3	Yes	No	No	No
MP-5221-0-0-1	MP-5211-0-0-3	Yes	No	No	No
MP-5221-500	MP-5211-500-0-3	Yes	No	No	Yes
MP-5221-500-0-1	MP-5211-500-0-3	Yes	No	No	No
MP-5222	MP-5230-0-0-3	No	No	Yes	Yes
MP-5222-0-0-1	MP-5230-0-0-3	No	No	Yes	No
MP-5222-500	MP-5320-0-0-3	Yes	No	Yes	Yes
MP-5222-500-0-1	MP-5230-0-0-3	Yes	No	Yes	No
MP-5223	MP-5233-0-0-3	No	No	No	Yes
MP-5223-0-0-1	MP-5233-0-0-3	No	No	No	No
MP-5223-500	MP-5230-0-0-3	Yes	No	No	Yes
MP-5223-500-0-1	MP-5233-0-0-3	Yes	No	No	No
MP-5230	MP-5230-0-0-3	No	No	No	No
MP-5230-500	MP-5230-0-0-3	Yes	No	No	No
MP-5231	MP-5211-0-0-3	Yes	No	No	No
MP-5231-500	MP-5230-0-0-3	Yes	No	No	No
MP-5232	MP-5230-0-0-3	No	No	Yes	No
MP-5232-500	MP-5230-0-0-3	Yes	No	Yes	No
MP-5233	MP-5233-0-0-3	No	No	No	No
MP-5233-500	MP-5233-500-0-3	No	No	No	No

^aAE-249 is 208 Vac to 120 Vac Transformer.

^bRefer to *Engineering Bulletin EN-111* section C1.1 for resistor value and wiring information.

MAINTENANCE

The actuator is sealed in oil and requires no maintenance.

Regular maintenance of the total system is recommended to assure sustained, optimum performance.

TROUBLESHOOTING

Use the following steps to locate malfunctions:

1. Disconnect control wiring.
2. Check for the proper supply voltage to the actuator.
3. The motor should run when power is applied. If it does not run, the actuator is inoperative and should be replaced.
4. With the actuator motor running:
 - a. Short the red lead to the yellow lead and observe the position indicator shown in Figure-5. The actuator should extend.
 - b. Short the blue lead to the Yellow lead, this should cause the indicator to retract.
 - c. If the actuator is installed on a damper check the linkage for any damage or misadjustment which could prevent the actuator from extending. If the mechanical linkage is inoperative, adjust the linkage or replace the damaged components, as applicable. If the mechanical linkage moves correctly and freely, the problem lies in the actuator and it must be replaced.
5. Reconnect control wiring.
6. If applying power directly to the actuator results in correct operation of the actuator, the actuator and linkage are functional, and the problem lies with the control signal. Repair or replace the controller, wiring, or thermostat, as applicable.

FIELD REPAIR

None. Replace an inoperative actuator with a functional unit.

DIMENSIONAL DATA

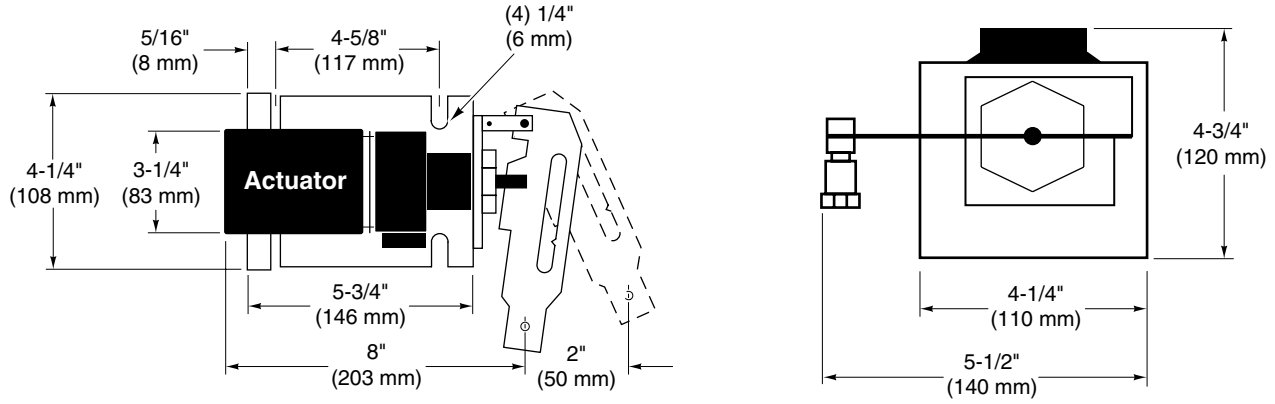

Figure-21 Damper Linkage Assembly Dimensions.

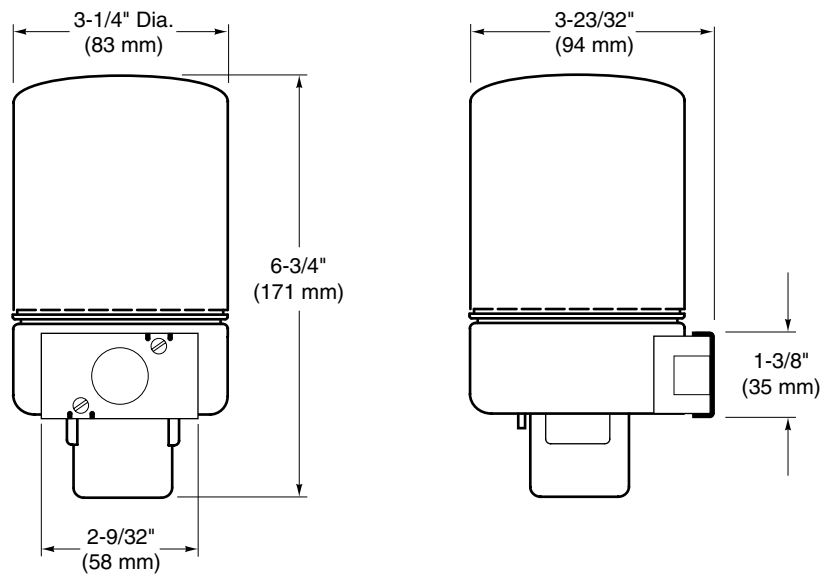

Figure-22 Actuator Dimensions.