

## Application

DuraDrive Direct Coupled Actuators are designed to be used in both damper and valve control applications. The following general instructions are for damper applications; refer to the Applicable Literature table for valve literature.

The MF4x-7xx3 series spring return actuators are used by SPDT floating controller for modulating dampers and valves in HVAC systems.

## Features

- Floating actuator controlled by SPDT floating controllers
- 133 lb-in (15 N-m), 60 lb-in (7 N-m), or 35 lb-in (4 N-m) of torque
- Rugged die cast housings rated for NEMA 2 / IP54
- Provides 95° of rotation
- Visual position indicator provided
- Optional built-in auxiliary switch to provide for interfacing or signaling
- Provides true mechanical clockwise or counterclockwise spring return operation for reliable spring return application and positive close-off in air tight damper applications
- Direct mount to round or square damper shafts
- Rotation limiting available
- MF4x-7153 series actuators can be double-mounted (gang mounting) to accommodate high torque application requirements
- Five year warranty
- MF41-707x and MF41-715x equipped with manual override

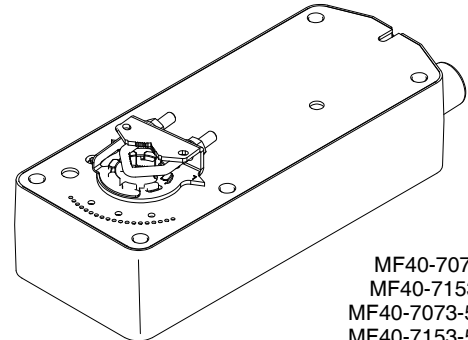

MF40-7073  
 MF40-7153  
 MF40-7073-502  
 MF40-7153-502

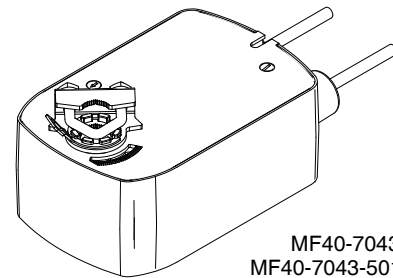

MF40-7043  
 MF40-7043-501

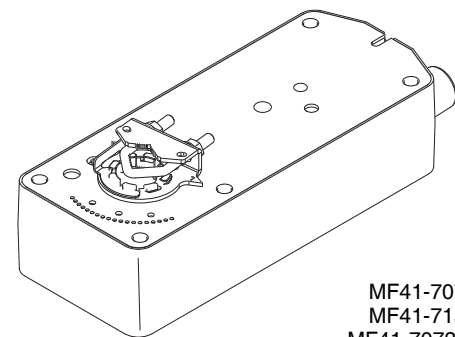

MF41-7073  
 MF41-7153  
 MF41-7073-502  
 MF41-7153-502

## Applicable Literature

F-Number	Description	Audience	Purpose
F-26750	MA4x-xxxx-2xx, MF4x-xxxx-2xx, MS4x-xxxx-2xx Series Actuator/Linkage Assemblies General Instructions	<ul style="list-style-type: none"> <li>– Sales Personnel</li> <li>– Application Engineers</li> <li>– Installers</li> <li>– Service Personnel</li> <li>– Start-up Technicians</li> </ul>	Describes the globe valve actuator/linkage assembly's features, specifications, and possible applications. Provides step-by-step mounting instructions.
F-26751	Vx-2000 Series Ball Valve Assembly Installations Instructions	<ul style="list-style-type: none"> <li>– Sales Personnel</li> <li>– Application Engineers</li> <li>– Installers</li> <li>– Service Personnel</li> <li>– Start-up Technicians</li> </ul>	Describes the actuator/linkage/ball valve assembly's features, specifications, and possible applications. Provides step-by-step mounting instructions.
F-26646	Mx4x-7xxx, Mx40-6xxx Series DuraDrive Actuator Selection Guide	<ul style="list-style-type: none"> <li>– Sales Personnel</li> <li>– Application Engineers</li> <li>– Installers</li> <li>– Service Personnel</li> <li>– Start-up Technicians</li> </ul>	Provides actuator specifications and part number cross referencing of phased out actuators with the new Invensys Building Systems direct-coupled actuators.
F-26752	Vx-2000, Vx-7000 Series and VB-2000 Series Ball and Globe Linked Valve Assemblies Actuator/Linkage Assemblies Selection Guide	<ul style="list-style-type: none"> <li>– Sales Personnel</li> <li>– Application Engineers</li> <li>– Installers</li> <li>– Service Personnel</li> <li>– Start-up Technicians</li> </ul>	Provides part number cross referencing of phased out globe and ball valve assemblies with the new Invensys Building Systems direct-coupled actuators.
F-26080	EN-205 Water System Guidelines	<ul style="list-style-type: none"> <li>– Application Engineers</li> <li>– Installers</li> <li>– Service Personnel</li> <li>– Start-up Technicians</li> </ul>	Describes Invensys Building Systems approved water treatment practices.
F-13755	CA-28 Control Valve Sizing	<ul style="list-style-type: none"> <li>– Application Engineers</li> <li>– Installers</li> <li>– Service Personnel</li> <li>– Start-up Technicians</li> </ul>	Provides charts, equations, and diagrams to assist in the configuration of valve system applications. TOOL-150, valve sizing slide rule may be purchased separately.
F-11080	Valve Selection Chart Water		
F-11366	Valve Selection Chart Steam (two-way valves only)		

# SPECIFICATIONS

## Actuator Inputs

**Control Signal:** Floating control, 24 Vac.

**Power Input:** See Table-1. All 24 Vac circuits are Class 2.

**Connections:** 3 ft. (91 cm) plenum rated cable for MF40-7043-xxx and 3 ft. (91 cm) appliance cable for MF4x-7153-xxx or MF4x-7073-xxx, 1/2" (13 mm) conduit connector. For M20 Metric conduit, use AM-756 adaptor.

## Actuator Outputs

**Electrical:**

**Auxiliary Switch:**

**MF40-7043-501** One SPDT 6A (1.5A) @24 Vac, Switch adjustable 0 to 95° (0 to 1 scale).

**MF4x-7153-502 or MF4x-7073-502** Two SPDT 7A (2.5A) @250 Vac, One fixed @ 5° and one adjustable 25 to 85°.

**Mechanical:**

**Stroke,** Angle of rotation 95° ±5°. Adjustable 30° to 95° with AM-689 installed on MF4x-7153-xxx or MF4x-7073-xxx. MF40-7043-xxx models are adjustable 40° to 95° by adjusting the stop block position on the actuator.

**Damper Shaft Clamp,**

**MF40-7043-xxx** The factory installed universal clamp is used for shafts up to 5/8" (15 mm) diameter or up to 1/2" (13 mm) square. AM-710 accessory clamp is required when mounting actuators to shafts up to 3/4" (19 mm) diameter or up to 1/2" (13 mm) square.

**MF4x-7153-xxx or MF4x-7073-xxx** The factory installed universal clamp is used for shafts up to 3/4" (19 mm) diameter or up to 1/2" (13 mm) square. AM-687 accessory clamp is required when mounting actuators to shafts up to 1.05" (27 mm) in diameter or up to 5/8" (15 mm) square.

**Position Indicator,** Visual indicator.

**MF4x-7153 and MF4x-7073,** -5 to 90° (-5° is spring return position).

**MF40-7043,** 0 to 1 (0 is spring return position).

**Nominal Damper Area,** Actuator sizing should be done in accordance with damper manufacturer's specifications.

**Direction of Rotation,** Clockwise or counterclockwise rotation determined by actuator mounting.

**Manual Override,** MF41-7073 and MF41-7153 are equipped with a manual rotation adjustment from -5 to 85°.

## Environment

**Ambient Temperature Limits:**

**Shipping & Storage,** -40 to 160°F (-40 to 71°C).

**Operating,** -22 to 140°F (-30 to 60°C).

**Humidity:** 15 to 95% RH, non-condensing.

**Location:**

**MF4x-7153-xxx and MF4x-7073-xxx,** NEMA 1 (IEC IP30). NEMA 2 (IEC IP54) with conduit connector in the down position.

**MF40-7043-xxx,** NEMA 2 (IEC IP54) no restrictions.

## Agency Listings

**UL 873:** Underwriters Laboratories (File # E9429 Category Temperature-Indicating and Regulating Equipment).

**CUL:** UL Listed for use in Canada by Underwriters Laboratories. Canadian Standards C22.2 No. 24-93.

**European Community:** EMC Directive (89/336/EEC). Low Voltage Directive (72/23/EEC).

**Australia:** This product meets requirements to bear the C-Tick Mark according to the terms specified by the Communications Authority under the Radiocommunications Act 1992.

**Table-1 Model Chart.**

Part Numbers	Actuator Power Input							Approximate Timing in Seconds @ 70° (21°C) <sup>a</sup>		Auxiliary Switch	Output Torque Rating lb.-in. (N-m) <sup>b</sup>	
	Voltage	Running				Holding	Powered	Spring Return	Minimum		Maximum Stall	
		50 Hz		60 Hz		DC Amps						50/60 Hz
		VA	W	VA	W							
MF4x-7153	24 Vac ± 20% 22 to 30 Vdc	9.8	7.7	9.7	7.7	0.30	3.3	<190	<30	No	133 (15)	350 (40)
MF4x-7153-502										Two <sup>c</sup>		
MF4x-7073		6.2	4.8	6.2	4.8	0.18	2.8	<195	<30	No	60 (7)	250 (28)
MF4x-7073-502										Two <sup>c</sup>		
MF40-7043		5.9	4.4	5.9	4.4	0.17	2.9	<130	<25	No	35 (4)	150 (17)
MF40-7043-501										One <sup>d</sup>		

<sup>a</sup> Timing was measured with no load applied to the actuator.  
<sup>b</sup> De-rating is required at low temperatures.  
<sup>c</sup> One adjustable from 25° to 85° rotation and one set to operate @ 5° fixed.  
<sup>d</sup> One adjustable from 0° to 95° rotation (0 to 1 scale).

**ACCESSORIES**

**For use with MF40-7xx3:**

- AM-671 Universal Mounting Bracket, AM-693 is required
- AM-672 Universal Mounting Bracket, AM-693 is required
- AM-673 Adjustable Mounting Bracket for multiple actuators
- AM-674 Weather Shield
- AM-675 Base Mounting Plate for AM-674
- AM-676 Universal Shaft Extension
- AM-714 Weather Shield (polycarbonate)
- AM-756 Metric Conduit Adapter M20 x 1.5 to 1/2" NPT
- AM-761 7-inch Anti-rotation Bracket
- AM-762 9-inch Anti-rotation Bracket

**For use with MF40-7043:**

- AM-709 Position Indicator and Stroke Limiter
- AM-710 Universal Clamp for up to 3/4" diameter shafts
- AM-711 Crankarm for up to 1/2" round shaft
- AM-712 Crankarm Adaptor Kit
- AM-713 Mounting Bracket for Honeywell Mod IV, M6415 type actuators and new installations
- AM-715 Crankarm Adaptor Kit for Honeywell Mod IV, M6415 type actuators and new installations
- AM-717 Replacement Universal V-Clamp for 1/2" diameter shafts

**For use with MF4x-7073, MF4x-7153:**

- AM-686 Damper Position Indicator
- AM-687 Universal Clamp for up to 1.05" (27 mm) diameter shafts.
- AM-688 Replacement Universal V-clamp
- AM-689 Rotation Limiter
- AM-690 Crankarm for round shafts up to 3/4" (19 mm)
- AM-691 Crankarm for jackshafts up to 1.05" (27 mm)
- AM-692 V-bolt Kit for AM-690 and AM-691 Crankarm
- AM-693 Damper Linkage Kit
- AM-758 Short "U" Mounting Bracket
- AM-759 Tall "U" Mounting Bracket
- AM-760 Slotted "L" Mounting Bracket
- AM-763 1/8" Hex Crank for Manual Override

## TYPICAL APPLICATIONS (wiring diagrams)

Figure-1 through Figure-5 illustrate typical wiring diagrams for spring return floating actuators. See Table-1 for model selection.

**Caution:** This product contains a half-wave rectifier power supply and must not be powered off transformers used to power other devices utilizing non-isolated full-wave rectifier power supplies. Refer to *EN-206, Guidelines for Powering Multiple Devices from a Common Transformer, F-26363* for detailed information.

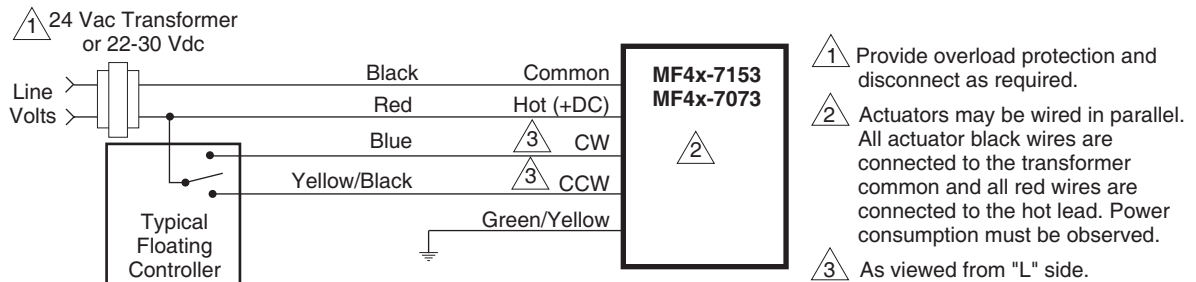
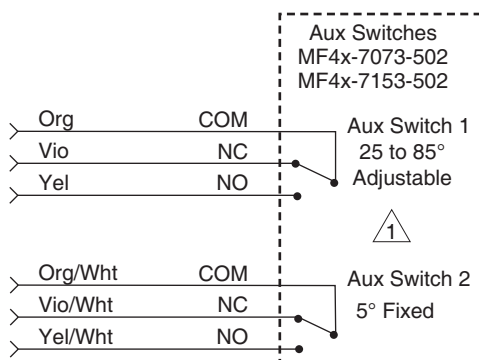

Figure-1 Floating Point Control.

### Optional Auxiliary Switches



**1** For end position indication, interlock control fan startup, etc., MF4x-7xx3-50x models incorporate one or two built-in auxiliary switches. See Specifications section for details.

Model #	Switch	Switch Type
MF4x-7153-502	A	Adjustable, 25° - 85°
MF4x-7073-502	B	Fixed at 5°
MF40-7043-501	A	Adjustable, 0 - 1 scale
	B	None

MF40-707x-502 and MF40-715x-502 units manufactured prior to the date code 0141 (October 6, 2001) used the following color coding for the auxiliary switches:

#### Auxiliary Switch 1

- Orange: Fixed auxiliary switch common (com)
- Yellow: Fixed auxiliary switch normally closed (NC)
- Violet: Fixed auxiliary switch normally open (NO)

#### Auxiliary Switch 2

- Orange/white: Adjustable auxiliary switch common (com)
- Violet/white: Adjustable auxiliary switch normally closed (NC)
- Yellow/white: Adjustable auxiliary switch normally open (NO)

The label information on these units is incorrect. If replacing these units, the auxiliary switch operation of the replacement actuator will be per the product label.

Figure-2 Optional Auxiliary Switches.

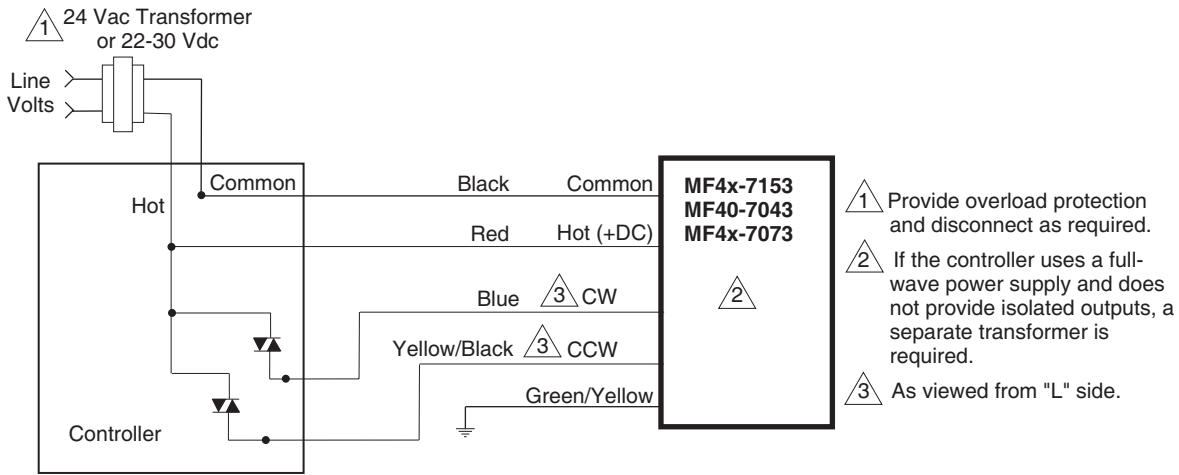

Figure-3 Triac source.

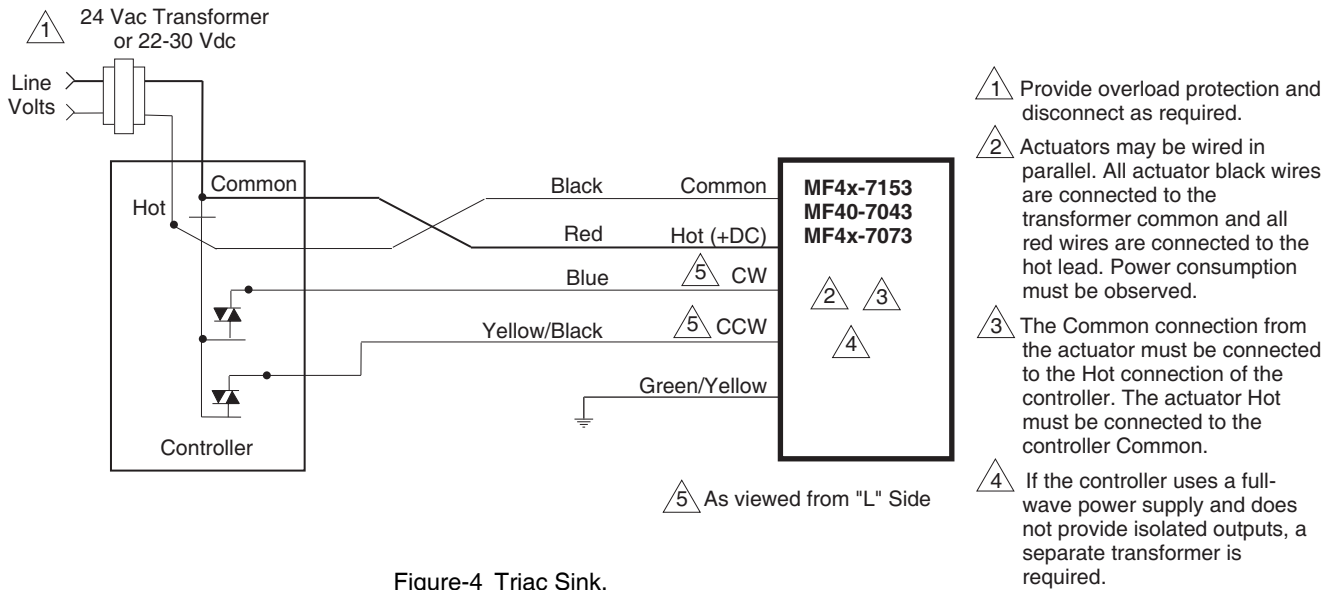

Figure-4 Triac Sink.

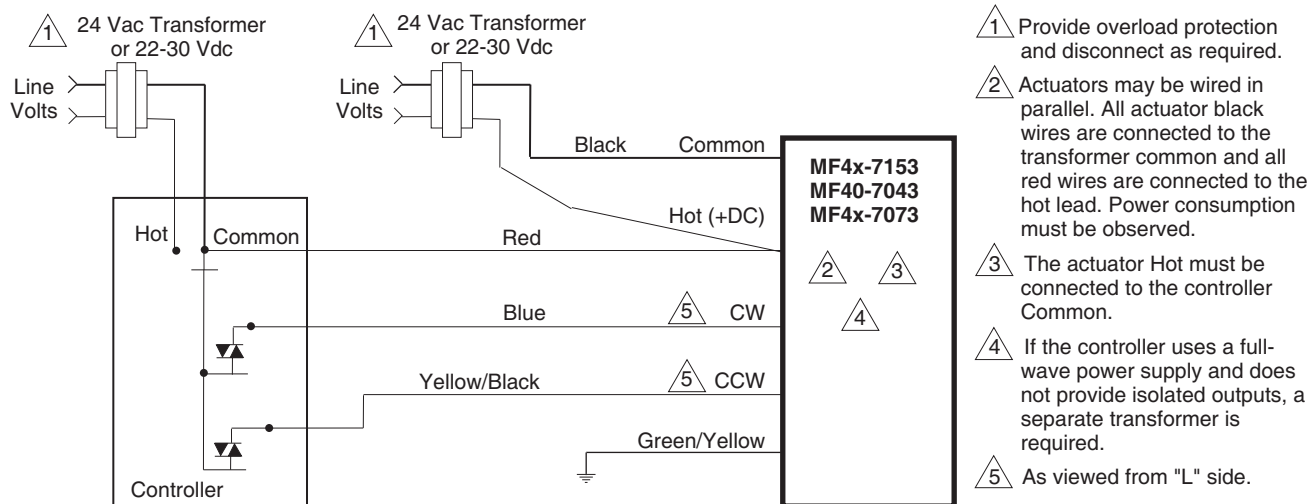

Figure-5

# INSTALLATION

## Inspection

Inspect the package for damage. If damaged, notify the appropriate carrier immediately. If undamaged, open the package and inspect the device for obvious damage. Return damaged products.

## Requirements

- Job wiring diagrams
- Tools (not provided)
  - #8 sheet metal screws
  - 10mm open end wrench or socket wrench
  - 1/8 inch, allen wrench
  - Appropriate screwdriver(s)
- Appropriate accessories
- Training: Installer must be a qualified, experienced technician

## Precautions



### General

---

#### **Warning:**

- Electrical shock hazard! Disconnect the power supply (line power) before installation to prevent electric shock and equipment damage.
  - Make all connections in accordance with the job wiring diagram and in accordance with national and local electrical codes. *Use copper conductors only.*
- 

#### **Caution:**

- Avoid electrical noise interference. Do not install near large contactors, electrical machinery, or welding equipment.
  - Do not drill holes in actuator body. Six pre-drilled holes are located on each side, under the label, to accept #10-24 thread-forming screws for mounting accessories.
- 

**Caution:** The Mx41-707x and Mx41-715x actuators are equipped with a manual override.

- The manual override is to be used only when power is not applied to the unit.
  - If the universal clamp is not set to 0° on the position indicator, manually wind the actuator in the direction indicated with hex wrench from -5° to 0° and lock with a screwdriver.
  - When operating manual override, back off 5° from full open mechanical stop to ensure proper release.
  - Do not attempt to use the manual override with actuators mounted in tandem. Damage to the gear train could occur.
- 

**Note:** When operating manual override, back off 5° from full open mechanical stop to ensure proper release.

---

### Federal Communications Commission (FCC)

**Note:** This equipment has been tested and found to comply with the limits for a Class B digital device, pursuant to Part 15 of the FCC Rules. These limits are designed to provide reasonable protection against harmful interference in residential installations. This equipment generates, uses, and can radiate radio frequency energy and may cause harmful interference if not installed and used in accordance with the instructions. Even when instructions are followed, there is no guarantee that interference will not occur in a particular installation. If this equipment causes harmful interference to radio or television equipment—which can be determined by turning the equipment off and on—the user is encouraged to try to correct the interference by one or more of the following measures:

- Reorient or relocate the receiving antenna.
  - Increase the separation between the equipment and receiver.
  - Connect the equipment to an outlet on a circuit different from that to which the receiver is connected.
  - Consult the dealer or an experienced radio/television technician for help.
-

## Canadian Department of Communications (DOC)

---

*Note:* This Class B digital apparatus meets all requirements of the Canadian Interference-Causing Equipment Regulations.

Cet appareil numérique de la classe B respecte toutes les exigences du Règlement sur le matériel brouilleur du Canada.

---

## European Standard EN 55022

---

**Warning:** This is a Class B digital (European Classification) product. In a domestic environment this product may cause radio interference in which case the user may be required to take adequate measures.

---

### Location

**Caution:** Avoid locations where excessive moisture, corrosive fumes, vibration, or explosive vapors are present.

---

### Mounting

**Caution:** To remain in NEMA 2/IP54 compliance, the MF40-7153 and MF40-7073 series actuators must be mounted with conduit end down.

---

Mount the DuraDrive Actuator directly on the damper shaft in locations that clear the maximum dimensions of the actuator case and allow the actuator to be mounted flush to the surface of the terminal box and perpendicular to the damper shaft.

---

**Caution:** Mx41-707x and Mx4x-715x: Do not attempt to use the manual override if actuators are mounted in tandem. Damage to the gear train could occur.

---

*Note:* Some terminal boxes have sheet metal screw heads or other protrusions near the damper shaft. In these cases, a spacer or shim may be added under the anti-rotation bracket of the actuator to make the actuator perpendicular to the shaft.

---

### Damper Actuator Sizing

Correct sizing of the actuator is necessary for proper control of dampers. The area of damper that can be controlled by a given actuator is dependent upon the type of damper, the quality of the damper, the pressure drop across the damper in the closed position, and the velocity of the air flow through the damper. To obtain actual damper torque requirements, contact the damper manufacturer.

### Damper Shaft Sizing

Use the “Long Damper Shaft” mounting instructions if the damper shaft is at least 3-1/2” (90 mm) long.

Use the “Short Damper Shaft” mounting instructions if the damper shaft is shorter than 3-1/2” (90 mm) or the area around the damper shaft is too narrow to allow standard mounting, as described in the “Short Damper Shaft” mounting section.



## MF40-7043 Series Installation

*Note:* The MF40-7043 series actuator comes equipped with standard universal mounting clamp. For damper shafts larger than 5/8" (16 mm) in diameter, the AM-710 universal mounting clamp is required (order separately). The AM-710 clamp accommodates shafts sizes up to 3/4" (19 mm) diameter shafts.

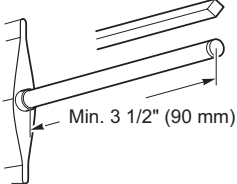
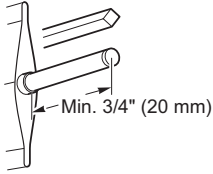
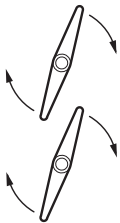
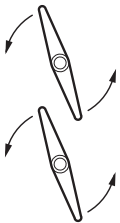
<p><b>Long Shaft</b></p>	 <p>Min. 3 1/2" (90 mm)</p>	<p><b>Short Shaft</b></p>	 <p>Min. 3/4" (20 mm)</p>
<p>Move the damper to its normal position. Verify the controller action is set to match the damper application.</p> <p>Normally closed damper: when damper is closed, actuator position indicator should be at 0°. When damper is open, actuator position indicator should be at 90°.</p> <p>Normally opened damper: when damper is open, actuator position indicator should be at 0°. When damper is closed, actuator position indicator should be at 90°.</p>			
<p><b>A - Left</b></p>	 <p><b>Shaft Rotates Clockwise To Open</b></p>	<p><b>A - Right</b></p>	 <p><b>Shaft Rotates Counterclockwise To Open</b></p>
<p>This step determines shaft rotation. Linkage may change damper direction.</p>			

### B - Left - Long Shaft

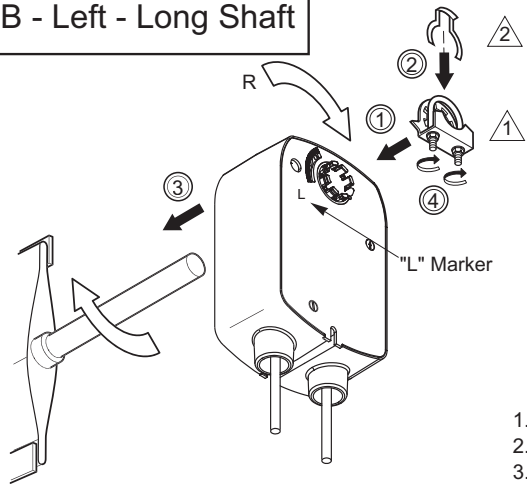

- ① Universal mounting clamp.
- ② Retaining clip.

1. Assemble mounting clamp.
2. Assemble retaining clip.
3. Place actuator over shaft.
4. Hand tighten clamp nuts.

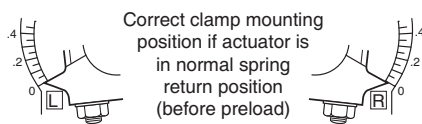

Correct clamp mounting position if actuator is in normal spring return position (before preload)

### B - Right - Long Shaft

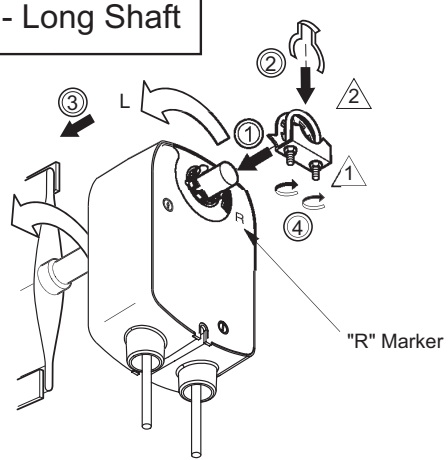

- ① Universal mounting clamp.
- ② Retaining clip.

1. Assemble mounting clamp.
2. Assemble retaining clip.
3. Place actuator over shaft.
4. Hand tighten clamp nuts.

### B - Left - Short Shaft

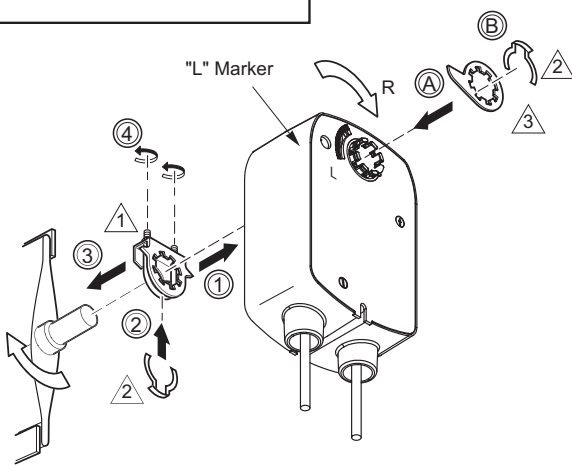

- ① Universal clamp.
- ② Retaining clip.
- ③ Damper position indicator.

- A. Assemble damper position indicator.
  - B. Assemble retaining clip.
1. Position mounting clamp.
  2. Assemble retaining clip.
  3. Slide actuator over shaft.
  4. Hand tighten clamp nuts.

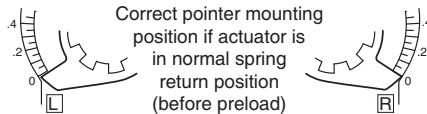

Correct pointer mounting position if actuator is in normal spring return position (before preload)

### B - Right - Short Shaft

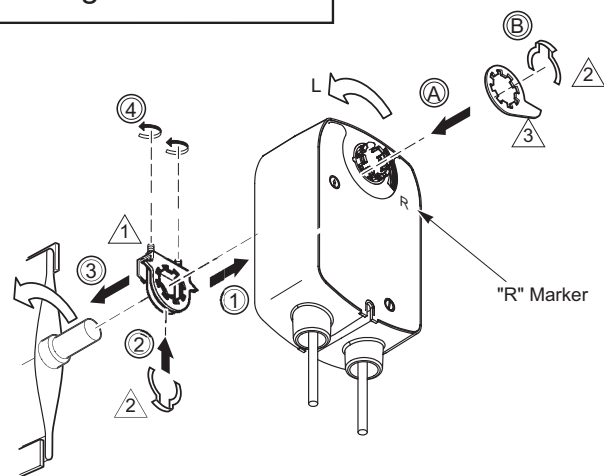

- ① Universal clamp.
- ② Retaining clip.
- ③ Damper position indicator.

- A. Assemble damper position indicator.
  - B. Assemble retaining clip.
1. Position mounting clamp.
  2. Assemble retaining clip.
  3. Slide actuator over shaft.
  4. Hand tighten clamp nuts.

### C - Left and Right

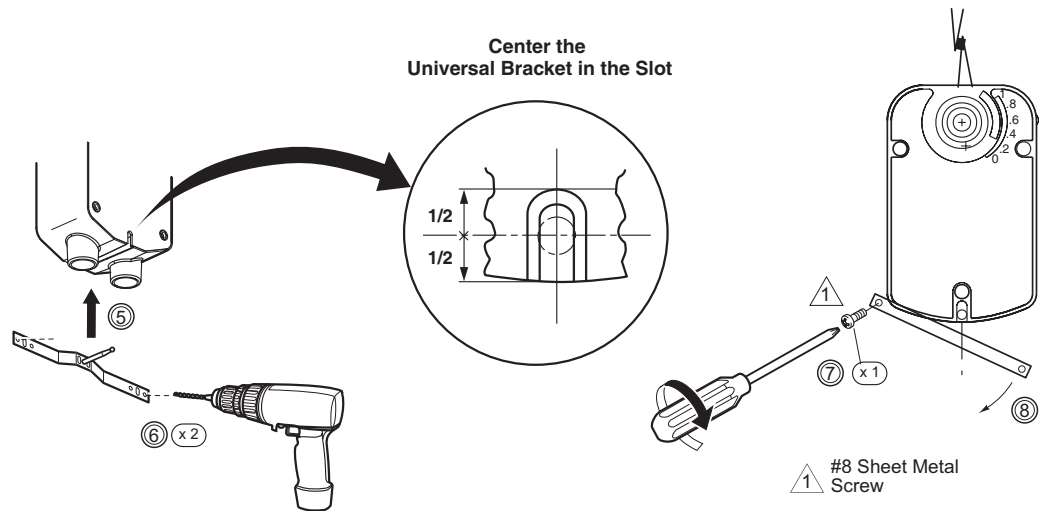

5. Center bracket in slot.
6. Drill two holes.
7. Start one screw.
8. Swing bracket down.

### D- Left

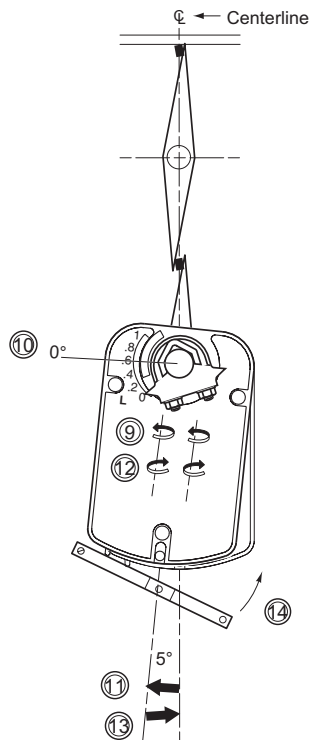

### D- Right

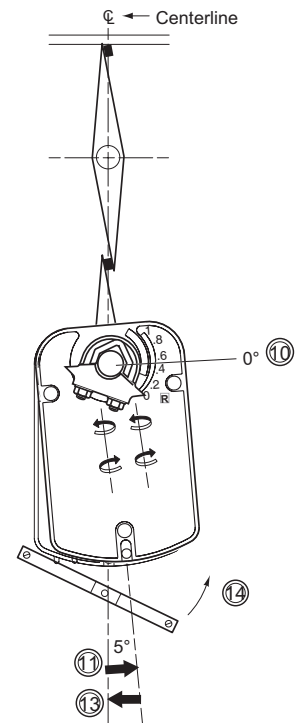

9. Loosen clamp nuts.
10. Check that the shaft is in full zero position.
11. Swing actuator 5° in the direction of travel. Do not move shaft.
12. Tighten clamp nuts to 4 to 6 lb-ft (5.4 to 8.2 N-m) of torque.
13. Move bottom of actuator back into position.
14. Pivot bracket back into position.

E- Left

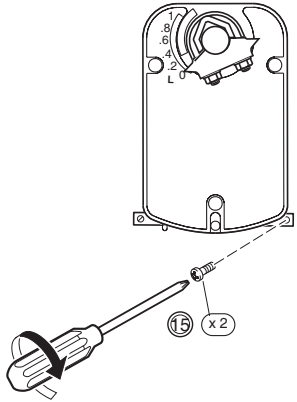

E - Right

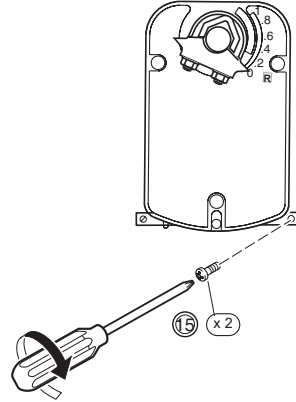

15. Tighten bracket screws.

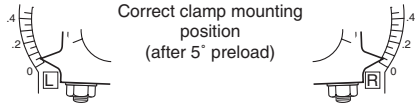

## MF4x-707x and MF4x-715x Series Installation

---

**Caution:** Do not drill additional holes in the actuator body. Six pre-drilled holes are located on each side, under the label, to accept #10-24 thread-forming screws for mounting accessories.

---

**Note:** The MF4x-707x and MF4x-715x series actuators come equipped with a standard universal mounting clamp installed. For damper shafts larger than 3/4" (19 mm) diameter, the AM-687 universal mounting clamp is required (order separately). The AM-687 clamp accommodates round shafts of up to 1-1/16" (27 mm) diameter and square shafts of up to 5/8" (16 mm) square.

---

**Caution:** The MF41-707x and MF41-715x actuators are equipped with a manual override.

- The manual override to be used only when power is not applied to the unit.
  - If the universal clamp is not set to 0° on the position indicator, manually wind the actuator in the direction indicated with hex wrench from -5° to 0° and lock with a screwdriver.
  - When operating manual override, back off 5° from full open mechanical stop to ensure proper release.
  - Do not attempt to use the manual override with actuators mounted in tandem. Damage to the gear train could occur.
  - To unlock manual override without power, crank the manual override in the direction indicated a minimum of 5°.
  - Using power tools to adjust the manual override will cause damage to gears.
-

A - Left

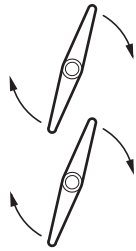

Shaft Rotates  
Clockwise  
To Open

A - Right

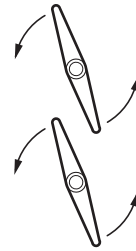

Shaft R  
Countercl  
To O

This step determines  
shaft rotation. Linkage  
may change damper direction.

B

For MF41-707x and MF41-715x only (manual override).  
For MF40-707x and MF40-715x, proceed to step C.

If position indicator does not point to zero: Unlock the actuator.

Insert hex wrench into manual override.

Crank the actuator so the indicator points to 0

Lock the actuator.

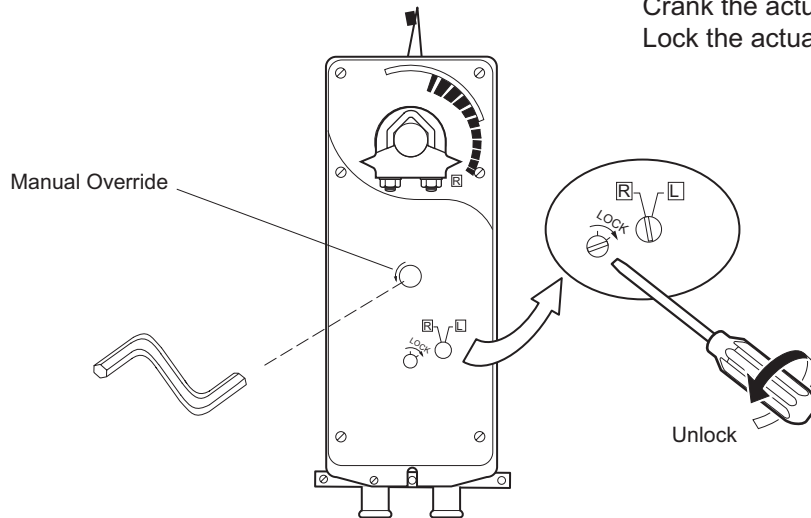

**Caution:** Do not crank the  
override if power  
to the actuator.

### C - Left - Long Shaft

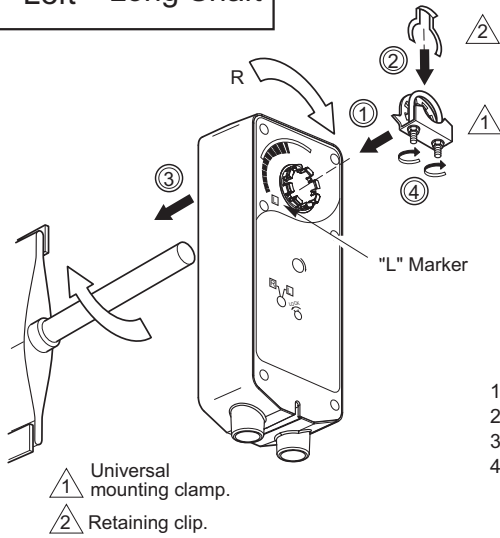

For MF40-707x and MF40-715x actuators:

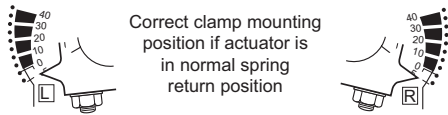

### C - Right - Long Shaft

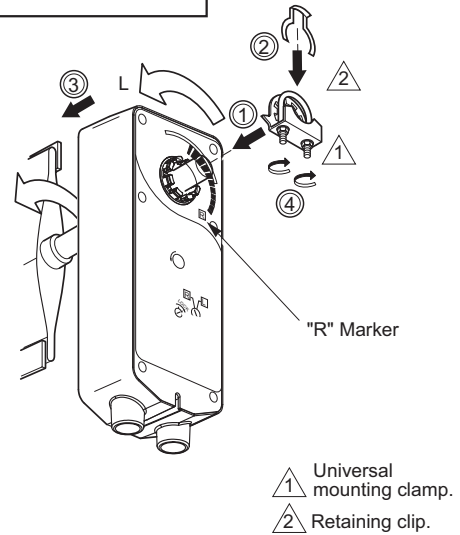

For MF41-707x and MF41-715x actuators:

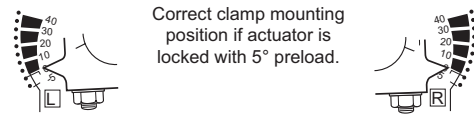

### C - Left - Short Shaft

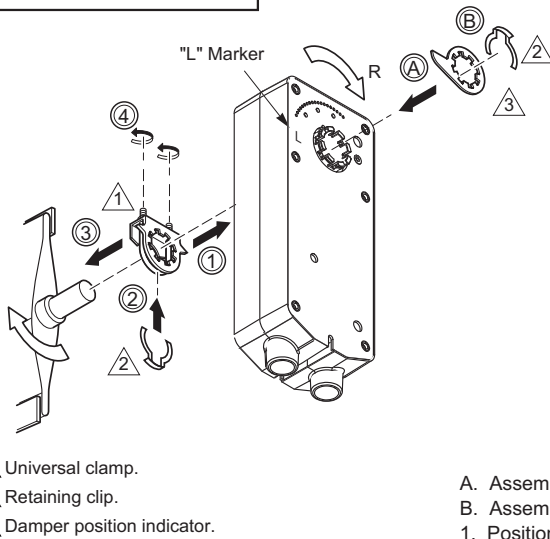

For MF40-707x and MF40-715x actuators:

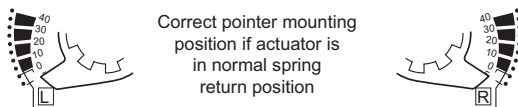

### C - Right - Short Shaft

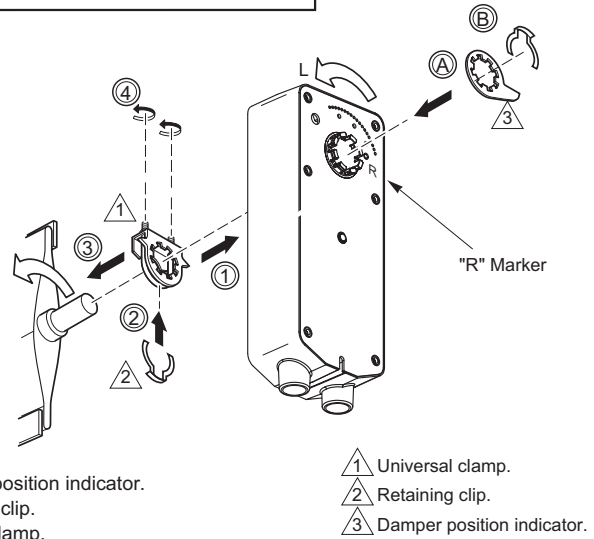

For MF41-707x and MF41-715x actuators:

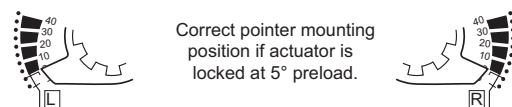

## D - Left and Right

Center the  
Universal Bracket in the Slot

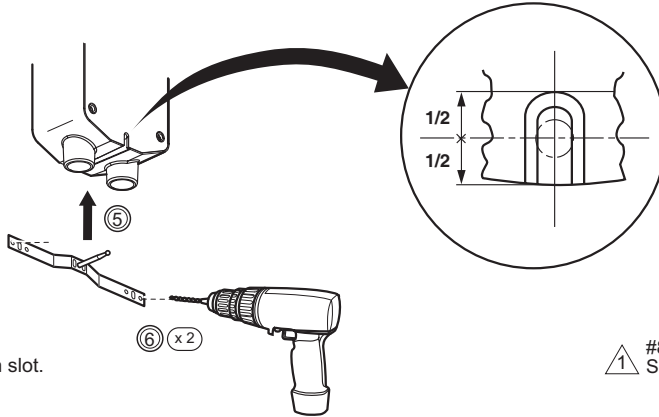

5. Center bracket in slot.
6. Drill two holes.
7. Start one screw.  
For MF41-707x and MF41-715x actuators, insert and tighten both screws.
8. Swing bracket down (MF40 actuator only).

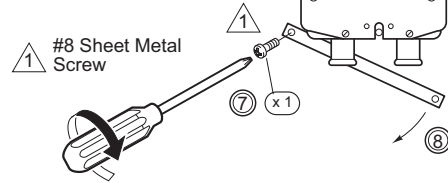

## E- Left

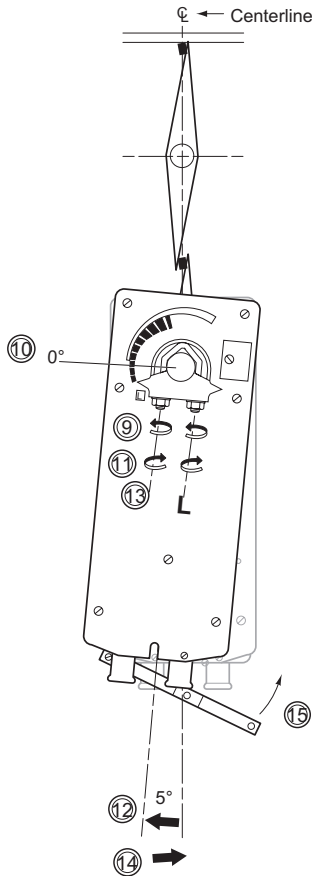

9. Loosen clamp nuts.
10. Check that the shaft is in full zero position.

### For MF41-707x and MF41-715x only:

11. Tighten clamp nuts to 6 - 8 in-lb (8.2 Nm).  
This completes the installation for MF41-704x and MF41-715x.

### For MF40-707x and MF40-715x only:

12. Swing actuator 5° in the direction of travel. Do not move shaft.
13. Tighten clamp nuts to 6 - 8 lb-in (8.2 - 10 N-m).
14. Move bottom of actuator back into position.
15. Pivot bracket back into position.

## E- Right

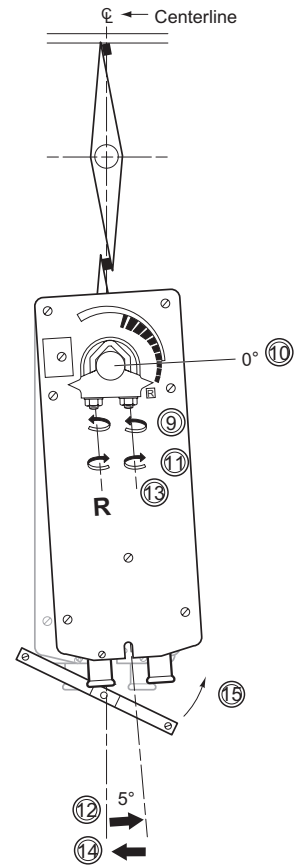



F- Left

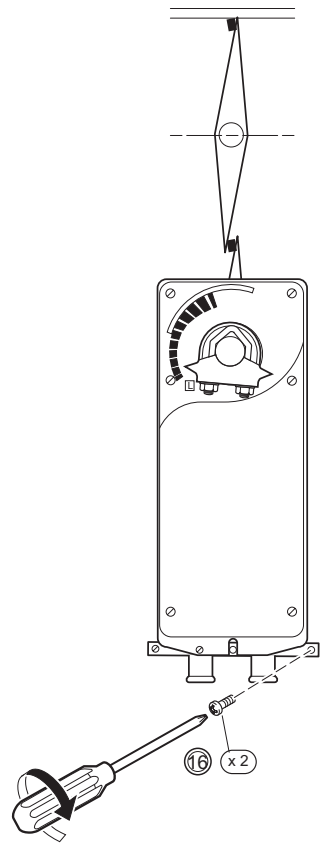

F- Right

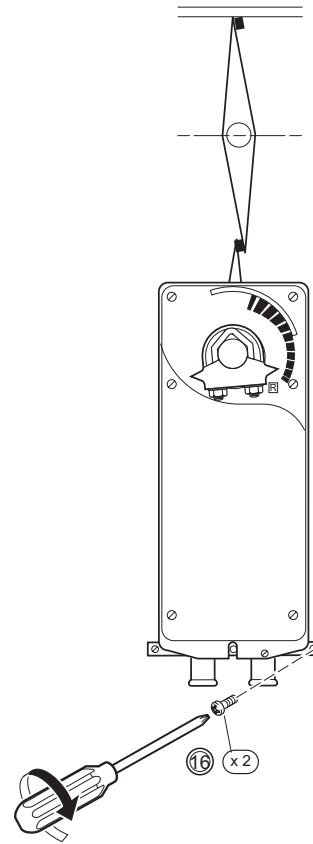

**For MF40-707x and MF40-715x only:**  
16. Tighten bracket screws.

For MF40-707x and MF40-715x actuators:

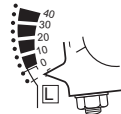

Correct pointer position  
after mounting.



For MF41-707x and MF41-715x actuators:

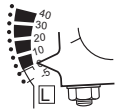

Correct pointer position  
after mounting.

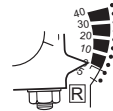

The lock on MF41-707x and MF41-715x will release on first power-up.

## Jackshaft Installation

### (MF40-7043 Series)

The MF40-7043 actuator is designed for use with jackshafts up to 3/4" (19 mm) in diameter. In most applications, the MF40-7043 actuator may be mounted in the same manner as a standard damper shaft application. If the jackshaft diameter is larger than 5/8" (16 mm) in diameter, the optional AM-710 universal clamp must be used.

### (MF4x-7153 and MF4x-7073 Series)

The MF4x-7153 and MF4x-7073 actuators are designed for use with jackshafts up to 1.05" (27 mm) in diameter. In most applications, the actuator may be mounted in the same manner as a standard damper shaft application. If the jackshaft diameter is larger than 3/4" (19 mm) in diameter, the optional AM-687 universal clamp must be used.

## Multiple Actuator Mounting

If more torque is required than one actuator can provide, a second actuator may be mounted to the jackshaft or standard damper shaft, using the AM-673 multiple mounting bracket. See Figure-6.

Multiple actuators may be powered from one transformer provided the following rules are followed:

- The total current draw of the actuators (VA rating) is less than, or equal to, the rating of the transformer.
- Polarity on the secondary of the transformer is strictly followed.
  - All Black wires from all actuators are connected to the common lead on the transformer.
  - All Red wires from all actuators are connected to the hot lead.

---

**Caution:** Do not attempt to use the manual override with actuators mounted in tandem. Damage to the gear train might occur.

---

---

**Caution:** Mixing the Black and Red wires on one lead of the transformer may result in erratic operation or failure of the actuator and/or controls.

---

Multiple actuators positioned by the same control signal may be powered from multiple transformers provided the following rules are followed:

- The transformers are properly sized.
- All Black wires from all actuators are tied together and tied to the negative lead of the control signal.

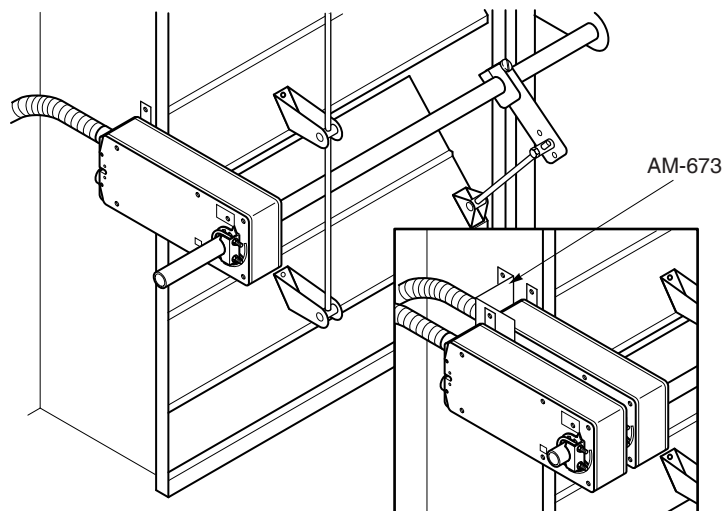

Figure-6 Mounting Multiple Actuators.

## Wiring Requirements

### Control Leads

See Table-2 for control and power wiring data. Refer to Figure-1 through Figure-5 for typical wiring.

**Table-2 Power Wiring.**

Actuator Voltage	Part Number	Maximum Wire Run in ft. (m)					
		12 AWG	14 AWG	16 AWG	18 AWG	20 AWG	22 AWG
24 Vac 22-30 Vdc	MF4x-7153	500	300	200	130	80	50
	MF4x-7153-502	(152)	(91)	(61)	(40)	(24)	(15)
	MF40-7043	1000	600	400	250	160	100
	MF40-7043-501	(305)	(183)	(122)	(76)	(49)	(30)
	MF4x-7073	1000	600	400	250	160	100
	MF4x-7073-502	(305)	(183)	(122)	(76)	(49)	(30)

### Auxiliary Switch

The MF40-7043-501 series actuators include one built-in SPDT auxiliary switch which can be used for interfacing or signaling (e.g., for fan start-up). The switch is adjustable between 0° and 95° of rotation (0 to 1 scale).

The MF4x-7153-502 and MF4x-7073-502 series actuators include two built-in SPDT auxiliary switches which can be used for interfacing or signaling (e.g., for fan start-up). The switch position near the normal (spring return) position is fixed at 5°. The other is adjustable between 25° and 85° of rotation.

### Adjusting the Switching Point

Refer to Table-3 for auxiliary switch rating.

#### Adjusting the switching point for MF40-7043-501

1. The actuator must be in its normal (spring return) position.
2. Use a flat screw driver to rotate the switch pointer until it is at the desired switch position on the 0 to 1 scale.

#### Adjusting the switching point for MF4x-7153-502 or MF4x-7073-502

1. The actuator must be in its normal (spring return) position.
2. Insert a 1/8" allen wrench into the hex hole located in the center of the adjustable switch pointer.
3. Rotate the wrench until the switch pointer is at the desired switch position in degrees, from 25 to 85°.

**Table-3 Auxiliary Switch Rating.**

Part Number	Voltage	Resistive Load	Inductive Load
MF40-7043-501	24 Vac	6A	1.5A
MF4x-7153-502	250 Vac	7A	2.5A
MF4x-7073-502			

## Rotation Limitation

### Rotation Limitation for MF40-7043 Series

The Stop Block is used in conjunction with the tab on the universal clamp or the AM-709 position indicator. In order to function properly, the clamp or indicator must be mounted correctly.

The Stop Block controls the rotational output of the MF40-7043 and MF40-7043-501 actuators. It is used in applications where a damper has a designed rotation that is less than 90°, for example with a 45° or 60° rotating damper. It can also be used to provide a minimum damper position which is easily set, or changed, without removing the actuator from the damper.

1. Determine the amount of damper rotation required. The actuator stop block provides limited rotation from 40° to 95°.
2. Loosen the screw securing the stop block to the actuator.

---

*Note:* The actuator is shipped with the Stop Block mounted to the “L” side. If the damper application requires the “R” side face the installer, simply remove the Stop Block and screw and move it to the new location.

---

3. Slide the stop block into position, so that its edge lines up with the degree graduation on the actuator face which corresponds with the required rotation. See Figure-7.
4. Secure the stop block in place.
5. Test the damper rotation by applying power and the required control signal. Re-adjust if necessary.

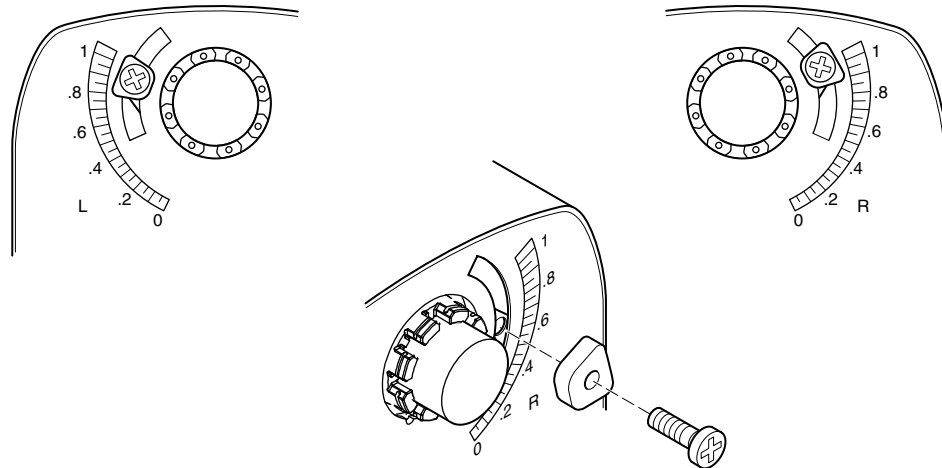

Figure-7 Adjusting Stop Block for Limited Rotation.

## Rotation Limitation for MF4x-7153 and MF4x-7073 Series

The AM-689 rotation limiter is used in conjunction with the tab on the universal clamp or the AM-686 position indicator which comes with the AM-689. In order to function properly, the clamp or indicator must be mounted correctly.

The AM-689 rotation limiter controls the rotational output of the MF4x-7153, MF4x-7153-502, MF4x-7073, and MF4x-7073-502 actuators. It is used in applications where a damper has a designed rotation that is less than 90°, for example with a 45° or 60° rotating damper. It can also be used to provide a minimum damper position which is easily set, or changed, without removing the actuator from the damper.

1. Determine the amount of damper rotation required.
2. Locate the AM-689 rotation limiter on the actuator so that its edge lines up with the degree graduation on the actuator face which corresponds with the required rotation. See Figure-8.
3. Find the appropriate cross-hair location through the slot of the rotation limiter. This is the mounting location for the retaining screw.
4. Pierce through the label material to allow easy fastening of the retaining screw.
5. Position the rotation limiter back to the desired position, making sure the locating “teeth” on the rotation limiter are engaged into the locating holes on the actuator.
6. Fasten the rotation limiter to the actuator using the self-tapping screw provided.
7. Test the damper rotation by applying power and the required control signal. Re-adjust if necessary.

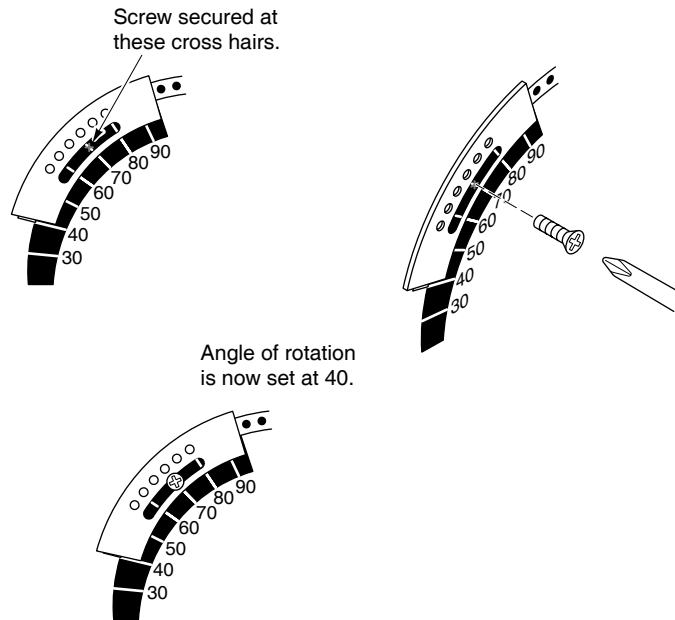

Figure-8 Securing the AM-689 Rotation Limiter.

## Minimum Damper Positioning

*Note:* When using the AM-689 rotation limiter with an MF4x-7073 or MF4x-7153 actuator to provide a minimum damper position, the short shaft mounting procedure must be used to mount the actuator.

**Caution:** The AM-689 rotation limiter should not be used with an MF4x-7073 or MF4x-7153 actuator to provide a minimum damper position in outdoor air damper applications. The rotation limiter prevents the damper from reaching the full-closed position. This may cause coils to freeze or may cause other system problems to occur.

1. Position the damper to its minimum position by applying power and the appropriate control signal to the MF4x-7073 or MF4x-7153.
2. Place the position indicator onto the actuator spline in the approximate position shown in Figure-9. Fasten it with the retaining clip.

*Note:* The actuator mounting orientation is different than when mounting it for damper rotation limiting.

3. Place the AM-689 rotation limiter on the actuator so that it either makes contact with, or is as close as possible to, the edge of the indicator. See Figure-10.
4. Make sure that the locating teeth are engaged into the locating holes on the actuator. If all of the mounting teeth do not align with the holes, the mounting location of the indicator to the spline may have to be moved. The rotation limiter would then be remounted to get the best position match of both parts.
5. Find the cross-hair location through the slot of the rotation limiter. This is the mounting location for the retaining screw.
6. Pierce through the label material to allow easy fastening of the retaining screw.
7. Fasten the rotation limiter to the actuator using the self tapping screw provided.
8. Test the damper by applying power and the required control signal. Re-adjust if necessary.

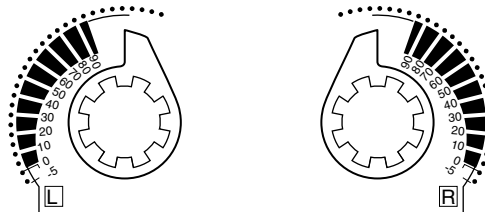

Figure-9 Installing the Position Indicator.

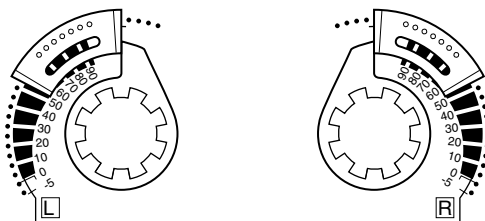

Figure-10 Positioning the Rotation Limiter.

## CHECKOUT

After the entire system has been installed and the actuator has been powered up, the following check can be made for proper system operation. Check for correct operation of the damper while actuator is being stroked.

1. Apply power to the actuator and cycle control system to drive the actuator clockwise or counterclockwise.
2. On the MF4x-7xx3-50x models, check for correct auxiliary switch operation.
3. Break power to the actuator. Actuator and damper should return to the spring return position.

---

*Note:* Check that the transformer(s) are sized properly.

- If a common transformer is used, make sure that polarity is observed on the secondary. This means connect all Black wires to one leg of the transformer and all Red wires to the other leg of the transformer.
  - If multiple transformers are used with one control signal, make sure all Black wires are tied together and tied to control signal negative (-).
  - Controllers and actuators must have separate 24 Vac power sources.
- 

## Go, No Go Test

1. Disconnect the control leads from the controller.
2. Connect the Blue lead to the Red lead and apply power the actuator should drive open.
3. Connect the Red lead to the Yellow/black lead and apply power the actuator should drive closed.
4. Check for proper operation of damper as the actuator is stroked.
5. Reconnect the control wiring.

## THEORY OF OPERATION

The actuators are mounted directly onto a damper shaft using a universal V-clamp. When power is applied by the controller between the Drive Open and Common leads, the actuator rotates toward the open position, at the same time tensing the spring return safety mechanism. When power is applied by the controller between the Drive Closed and Common leads, the actuator rotates toward the closed position. When no power is applied to either the Drive Open or Drive Closed leads, the actuator remains at its current position. When power is removed from the Hot and Common leads of the actuator, the spring returns the actuator to its normal position. The actuators provide true mechanical spring return operation for reliable, positive close-off on air tight dampers.

All MF4x-7xx3-xxx series actuators use a brushless DC motor which is controlled by a microprocessor. The microprocessor supplies intelligence to provide a constant rotation rate and to know the actuator's exact normal position. The microprocessor monitors and controls the brushless DC motor's rotation and provides a digital sensing function to prevent damage to the actuator in a stall condition. The actuator may be stalled anywhere in its normal rotation, without the need for mechanical end switches.

The MF40-704x-501 models are provided with one built-in auxiliary switch. The SPDT switch is provided for interfacing or signaling, for example, fan startup. The switching function is adjustable between 0° and 95° rotation (0 to 1 scale).

The MF4x-707x-502 and MF4x-715x-502 models are provided with two built-in auxiliary switches. The SPDT switches are provided for interfacing or signaling, for example, fan startup. The switching function is adjustable on one switch between 25° and 95° rotation, and the other switch is fixed to operate at 5° rotation.

The MF41-707x-xxx and MF41-715x-xxx actuators are equipped with a manual override mechanism. This allows the actuator to be manually positioned at any point between -5° and 85° rotation. This mechanism is accessible on both sides of the actuator and can be used to ensure tight close-offs for valves and dampers. The manual override should not be used while a unit is powered or on units that are mounted in tandem.

## MAINTENANCE

Regular maintenance of the total system is recommended to assure sustained optimum performance. The MF4x series actuators are maintenance free.

## FIELD REPAIR

None. Replace with a functional actuator.

# DIMENSIONAL DATA

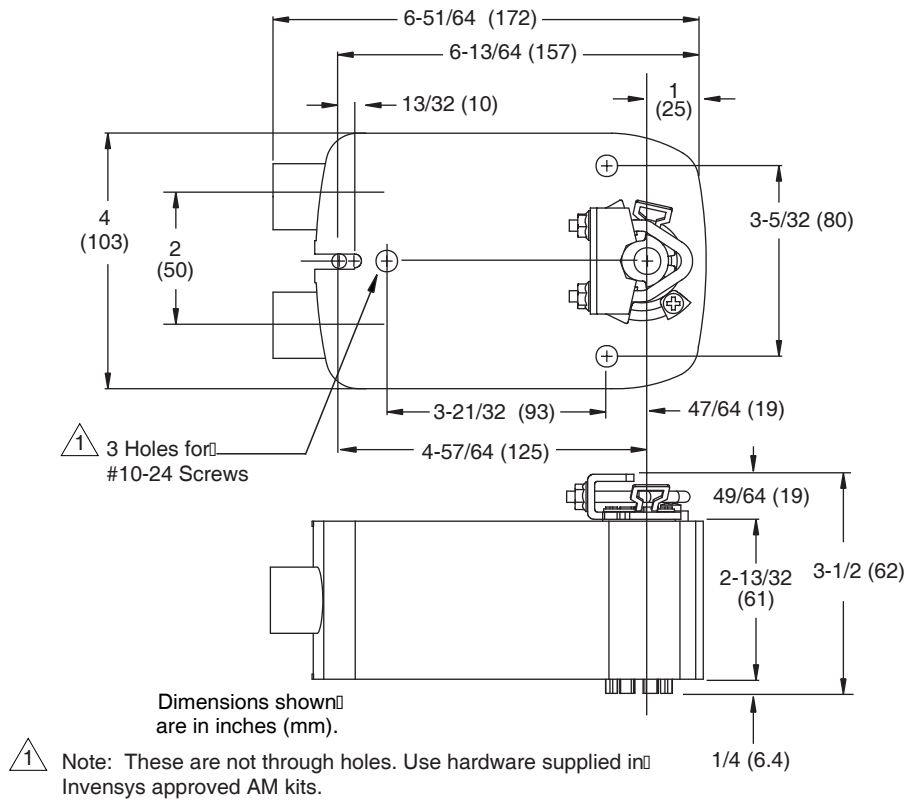

Figure-11 MF40-7043 Spring Return Damper Actuator Dimensions.

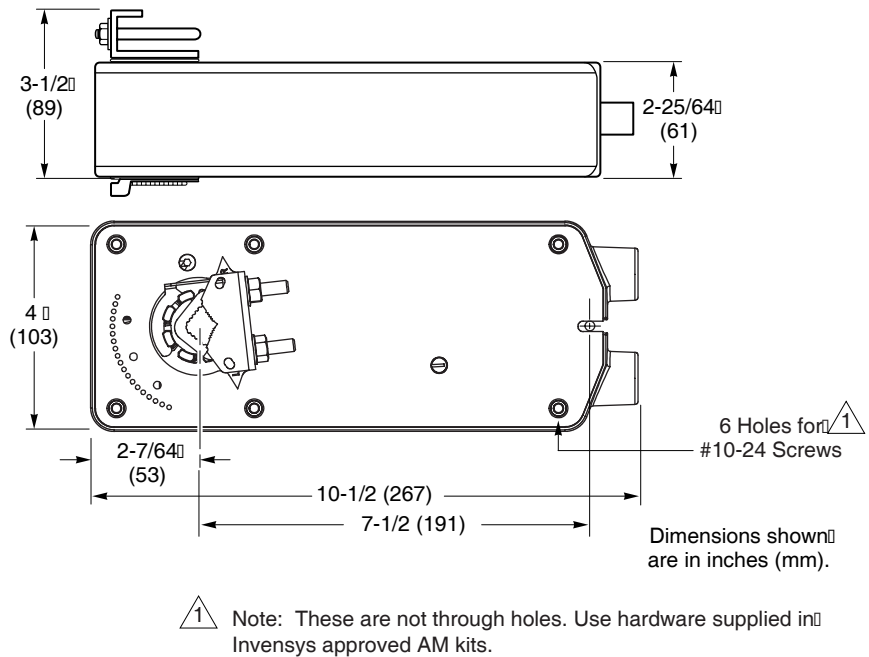

Figure-12 MF4x-7073 and MF4x-7153 Spring Return Damper Actuator Dimensions.

© Copyright 2004 Invensys Building Systems, Inc. All rights reserved.

No part of this document may be photocopied or reproduced by any means, or translated to another language without prior written consent of Invensys.

All specifications are nominal and may change as design improvements are introduced. Invensys shall not be liable for damages resulting from misapplication or misuse of its products.

Invensys and DuraDrive are trademarks of Invensys plc and its subsidiaries and affiliates.

All other trademarks are the property of their respective owners.