

Application

DuraDrive Direct Coupled Actuators are designed to be used in both damper and valve control applications. The follow general instructions are for damper applications, refer to the Applicable Literature table for valve literature.

The MS41-634X series actuators are over the shaft non-spring return actuators compatible with 2 to 10 Vdc or 4 to 20 mAdc control signals.

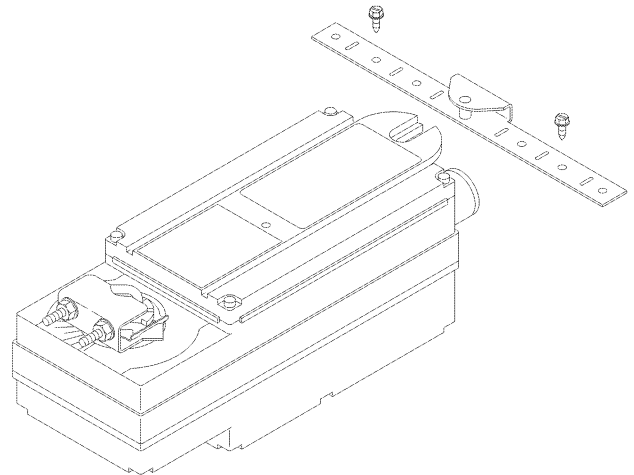

Features

- 300 lb-in (34 N-m) rated torque
- NEMA Type 4 housing (IEC IP56)
- Custom automatic current sensing motor control provides extended reliability and repeatable timing
- Direct coupled to the damper shaft with dual industrial hardened universal mounting clamps
- Integral wiring for proportional control by 2 to 10 Vdc or 4 to 20 mAdc
- Clockwise or counterclockwise rotation is determined by actuator mounting position
- Manual override for ease of installation and manual operation of damper
- Accurate 93° travel digitally controlled
- Integral position indication scale
- Rugged die-cast housing
- Oil immersed gear train provides continuous lubrication
- Rated for operating temperatures up to 140 °F (60 °C)
- Five year warranty



† Refer to Table-1 to identify specific models that are in conformance with CE standards.

Applicable Literature

F-Number	Description	Audience	Purpose
F-27160	Actuator/Linkage Assemblies for 2-1/2" to 6" globe Valves General Instructions	<ul style="list-style-type: none"> - Sales Personnel - Application Engineers - Installers - Service Personnel - Start-up Technicians 	Describes the globe valve actuator/linkage assembly's features, specifications, and possible applications. Provides step-by-step mounting instructions.
F-27082	AV-607, AV-609 DuraDrive Linkages for 2-1/2" to 6" Globe Valves General Instructions	<ul style="list-style-type: none"> - Sales Personnel - Application Engineers - Installers - Service Personnel - Start-up Technicians 	Describes the globe valve actuator/linkage assembly's features, specifications, and possible applications. Provides step-by-step mounting instructions.
F-26646	MX40-7XXX, MX41-6XXX Series DuraDrive Actuator Selection Guide	<ul style="list-style-type: none"> - Sales Personnel - Application Engineers - Installers - Service Personnel - Start-up Technicians 	Provides actuator specifications and part number cross referencing of phased out actuators with the new Invensys Building Systems direct-coupled actuators.
F-26752	VX-7000 & VX-9000 Series, MX41-6XXX, MX4X-7XXX Series, Linked Globe Valve Assemblies and Actuator/Linkage Assemblies with DuraDrive Actuators Selection Guide	<ul style="list-style-type: none"> - Sales Personnel - Application Engineers - Installers - Service Personnel - Start-up Technicians 	Provides features, specifications, mounting dimensions, and other criteria useful to the selection of linked globe valve assemblies and actuators/linkage assemblies with DuraDrive actuators.
F-25097	AM-674 Weather Shield General Instructions	<ul style="list-style-type: none"> - Sales Personnel - Application Engineers - Installers - Service Personnel - Start-up Technicians 	Provides step-by-step mounting instructions.
F-25098	AM-676 Universal Shaft Extension General Instructions	<ul style="list-style-type: none"> - Sales Personnel - Application Engineers - Installers - Service Personnel - Start-up Technicians 	Provides step-by-step mounting instructions.
F-26895	AM-703 Span Adjustment General Instructions	<ul style="list-style-type: none"> - Sales Personnel - Application Engineers - Installers - Service Personnel - Start-up Technicians 	Provides step-by-step mounting instructions.
	AM-704 Modular Interface General Instructions		
	AM-705 Positioner General Instructions		
	AM-706 Positioner General Instructions		
	AM-707 Digital Indication General Instructions		
	AM-708 Resistor General Instructions		
F-26898	AM-751 Standard Anti-rotation Bracket General Instructions	<ul style="list-style-type: none"> - Sales Personnel - Application Engineers - Installers - Service Personnel - Start-up Technicians 	Provides step-by-step mounting instructions.
	AM-752 Optional Anti-rotation Bracket General Instructions		
	AM-753 Optional Universal Mounting Clamps General Instructions		
	AM-754 Standard Universal Mounting Clamps General Instructions		
F-26899	AM-756 Metric Conduit Adaptor General Instructions	<ul style="list-style-type: none"> - Sales Personnel - Application Engineers - Installers - Service Personnel - Start-up Technicians 	Provides step-by-step mounting instructions.
F-26080	EN-205 Water System Guidelines	<ul style="list-style-type: none"> - Application Engineers - Installers - Service Personnel - Start-up Technicians 	Describes Invensys Building Systems approved water treatment practices.
F-13755	CA-28 Control Valve Sizing	<ul style="list-style-type: none"> - Application Engineers - Installers - Service Personnel - Start-up Technicians 	Provides charts, equations, and diagrams to assist in the configuration of valve system applications. TOOL-150, valve sizing slide rule may be purchased separately.
F-11080	Valve Selection Chart Water		
F-11366	Valve Selection Chart Steam (two-way valves only)		

SPECIFICATIONS

Inputs

Control Signal: 4 to 20 mA_{dc} or 2 to 10 V_{dc}. See Figure-1 through Figure-8.

Power Input: See Table-1. All 24 Vac circuits are Class 2. All circuits 30 Vac and above are Class 1.

Impedance: 10 k Ω for 2 to 10 V_{dc}, 500 Ω for 4 to 20 mA_{dc}.

Connections:

Power, 24 inch (61 cm) long, 18 AWG color coded pigtail leads.

Control, 24 inch (61 cm) long, 22 AWG color coded pigtail leads.

Outputs

Electrical:

Stroke, Electronically limited to 93° \pm 1°.

Action, Direct acting, 0° position with 4 mA_{dc} or 1 V_{dc} input.

Torque 300 lb-in (34 N-m) minimum, 600 lb-in (64 N-m) maximum stall.

Duty Cycle 100%.

Timing 145 seconds for 93° rotation at 70 °F (21 °C).

Mechanical:

Manual Override, Allows manual positioning.

Anti-Rotation Bracket,

Standard 9" long x 13/16" wide (229 x 21 mm), AM-751 is included with the actuator.

Optional Order AM-752 (4" long x 1-11/16" wide) for mounting the actuator in narrow spaces.

Universal Mounting Clamps, Two clamps are required for all mounting configurations.

Standard AM-754, 3/8" to 1/2" (10 to 13 mm) round and square shaft mounting clamps are included with the actuator.

Optional Order AM-753 for 5/8" (16 mm) square and 3/4" to 1" (19 to 25 mm) round damper shafts, two per package.

Minimum Damper Shaft Length,

Standard Damper shaft must be at least 4-5/8" (117 mm) long for standard mounting.

Optional Shorter than standard length shafts require the AM-676 shaft extension (order separately).

Position Indicator, Scale numbered from 0 to 95°, provided for position indication.

Nominal Damper Area, Actuator sizing should be done in accordance with damper manufacturer's specifications.

Direction of Rotation, Clockwise or counterclockwise rotation determined by actuator mounting. The zero (0) position on the position indicator is the normal position.

Environment

Ambient Temperature Limits:

Shipping & Storage, -40 to 160 °F (-40 to 71 °C).

Operating, -25 to 140 °F (-32 to 60 °C).

Humidity: 15 to 95% RH, non-condensing.

Location: NEMA Type 1. NEMA Type 4 (IEC IP56) with customer supplied water tight conduit connectors.

Agency Listings

UL 873: Underwriters Laboratories Inc. listed (File # E9429 Category Temperature-Indicating and Regulating Equipment).

CUL: UL Listed for use in Canada by Underwriters Laboratories. Canadian Standards C22.2 No. 24-93.

European Community: EMC Directive (89/336/EEC). Low Voltage Directive (72/23/EEC). Machinery Directive (89/392/EEC). Safety Directive (92/59/EEC).

Table-1 Model Chart.

Part Number	Actuator Power Input					Approximate 93° Rotation Timing in Seconds @ 70 °F (21 °C) for Rated Torque	Output Torque Rating lb.-in. (N-m)		
	Voltage	Hz		VA	Watts		Minimum	Maximum Stall	
					Running				Holding
MS41-6343 ^a	24 Vac ±20%	50	60	8	10	N/A	0 to 145	300 (34)	600 (64)
MS41-6340	120 Vac ±10%								
MS41-6341 ^a	240 Vac ±10%								

^a This model is in conformance with CE standards.

ACCESSORIES

AM-674	Weather Shield - steel
AM-676	Universal Shaft Extension, approximately 9-1/2" (242 mm) long for use on 3/8" to 11/16" (10 to 17 mm) round shafts, 3/8" to 9/16" (10 to 14 mm) square shafts (AM-753 clamps required)
AM-703	Span Adjustment
AM-704	Modulation Interface, converts a PWM to 2 to 10 Vdc
AM-705	Positioner, remote/minimum positioning
AM-706	Positioner, flush mount digital position indicator
AM-707	Digital Indication
AM-708	Resistor for 500Ω modulating signal conversion
AM-751	Standard Anti-rotation Bracket 9" long x 13/16" wide (229 x 21 mm), included with actuator
AM-752	Optional Anti-rotation Bracket 4" long x 1-11/16" wide (102 x 43 mm), for narrow spaces
AM-753	Optional Universal Mounting Clamps for 5/8" (16 mm) square shaft, to 1" (19 to 25 mm) Round Shafts (two per package)
AM-754	Standard Universal Mounting Clamps for 3/8" to 1/2" (10 to 13 mm) round and Square Shafts, two included with actuator
AM-755	Manual Override Crank
AM-756	Metric Conduit Adaptor M20 x 1.5 to 1/2" NPT (two per package)
X-5521	1/2" Pipe Plug, included with actuator

TYPICAL APPLICATIONS (wiring diagrams)

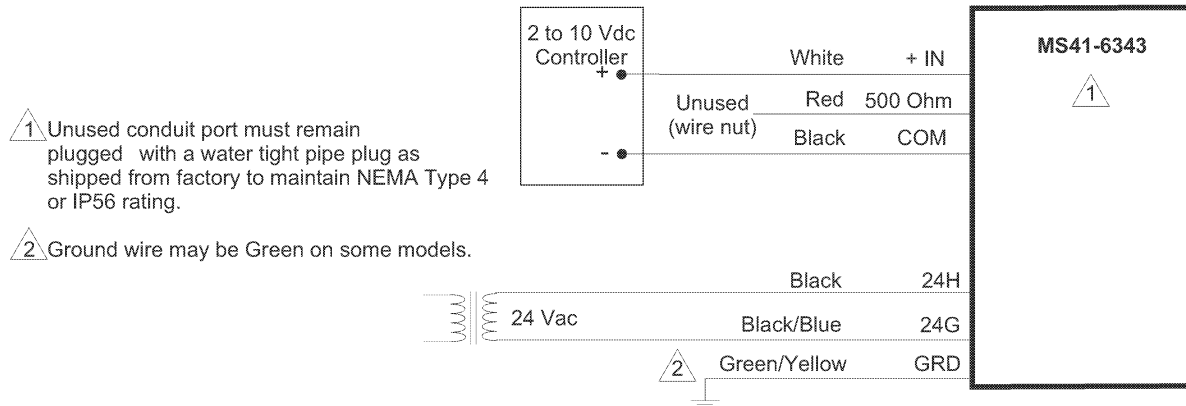

Figure-1 Typical Wiring Diagram for 2 to 10 Vdc Controller with a 24 Vac Actuator.

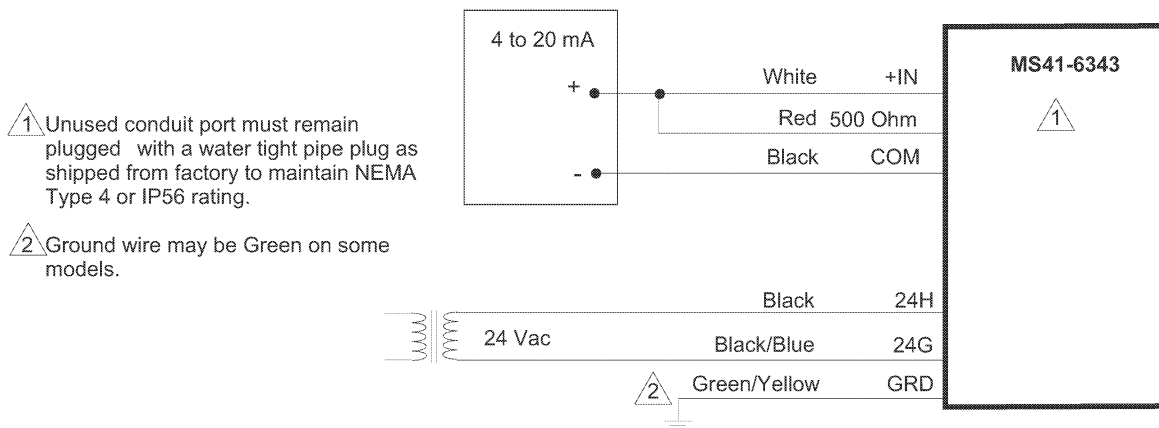

Figure-2 Typical Wiring Diagram for 4 to 20 mA Controller with a 24 Vac Actuator.

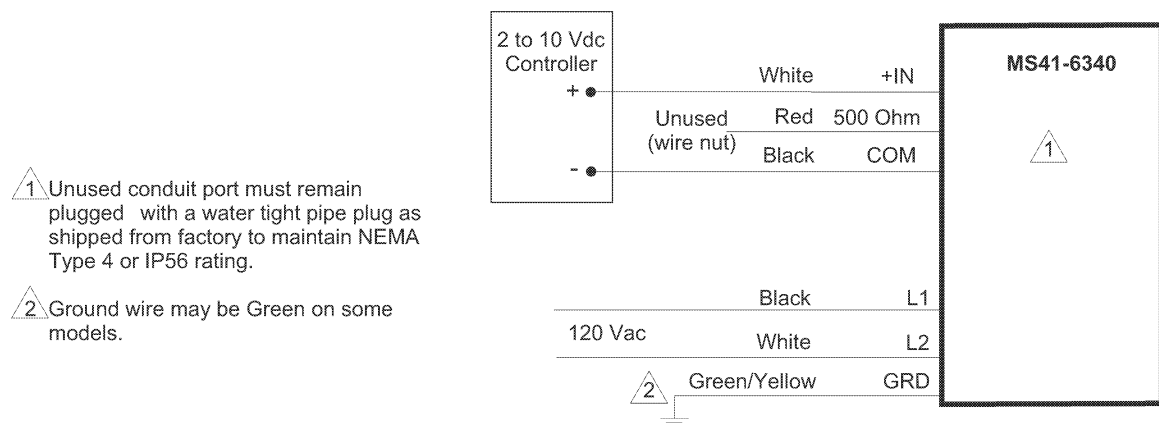

Figure-3 Typical Wiring Diagram for a 2 to 10 Vdc Controller with a 120 Vac Actuator.

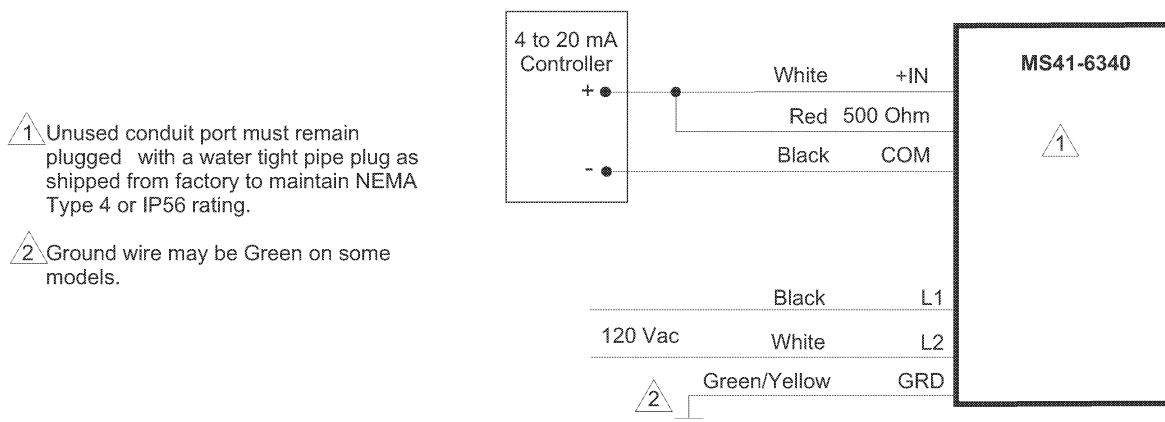

Figure-4 Typical Wiring Diagram for a 4 to 20 mA Controller with a 120 Vac Actuator.

1 Unused conduit port must remain plugged with a water tight pipe plug as shipped from factory to maintain NEMA Type 4 or IP56 rating.

2 Ground wire may be Green on some models.

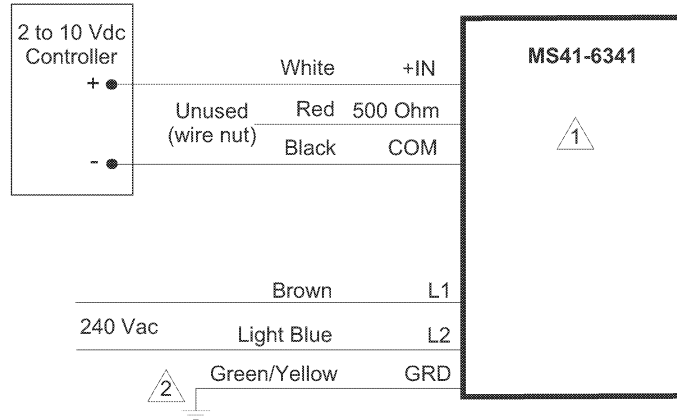

Figure-5 Typical Wiring Diagram for a 2 to 10 Vdc Controller with a 240 Vac Actuator.

1 Unused conduit port must remain plugged with a water tight pipe plug as shipped from factory to maintain NEMA Type 4 or IP56 rating.

2 Ground wire may be Green on some models.

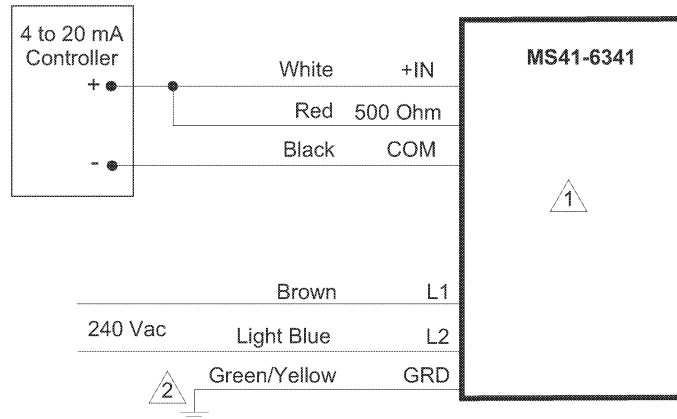
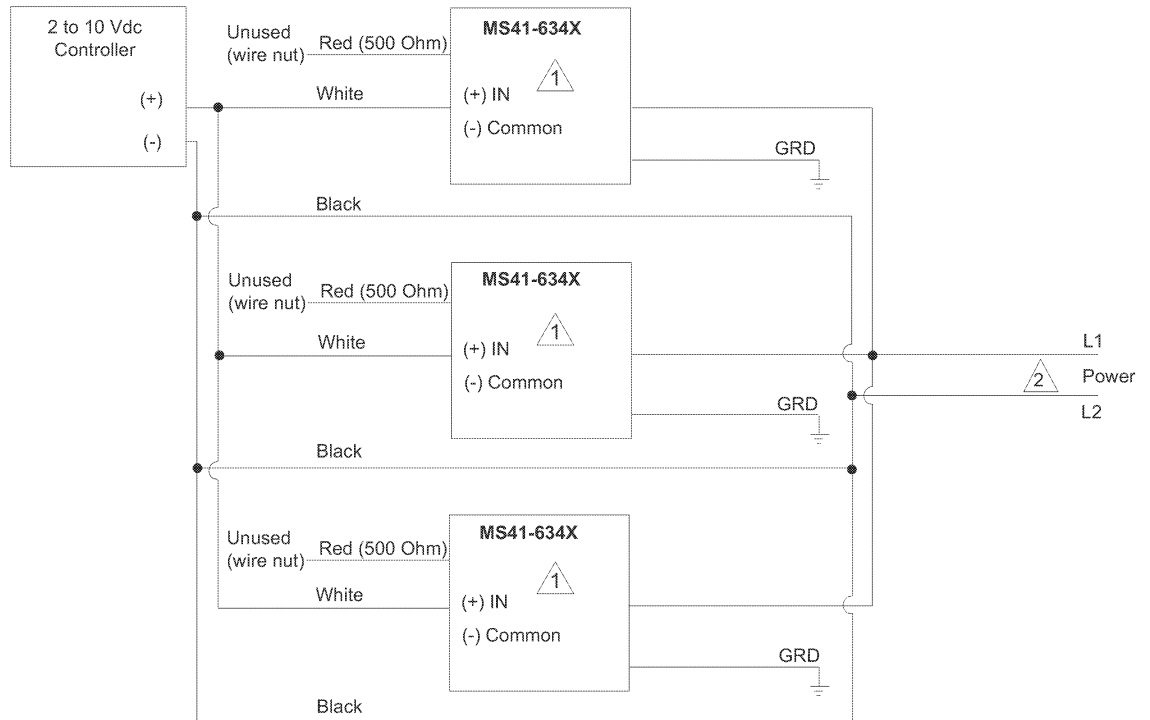

Figure-6 Typical Wiring Diagram for a 4 to 20 mA Controller with a 240 Vac Actuator.



1 Unused conduit port must remain plugged with a water tight pipe plug as shipped from factory to maintain NEMA Type 4 or IP56 rating.

2 See table for power wire designations. Ground wire may be Green or Green/Yellow on some models.

Power Wiring Identification.

Table-3

Voltage	Designation	Wire Color
24	L1	Black
	L2	Black/Blue
120	L1	Black
	L2	White
240	L1	Brown
	L2	Light Blue

Figure-7 Typical 2 to 10 Vdc Control Wiring using Multiple Actuators.

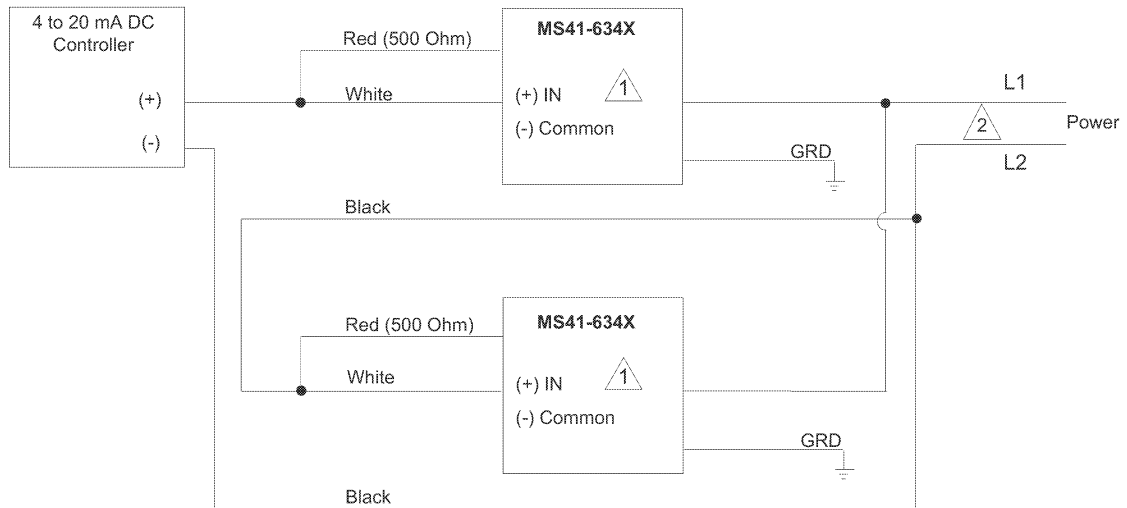

1 Unused conduit port must remain plugged with a water tight pipe plug as shipped from factory to maintain NEMA Type 4 or IP56 rating.

2 See table for power wire designations. Ground wire may be Green or Green/Yellow on some models.

Power Wiring Identification.

Table-3

Voltage	Designation	Wire Color
24	L1	Black
	L2	Black/Blue
120	L1	Black
	L2	White
240	L1	Brown
	L2	Light Blue

Figure-8 Typical 4 to 20 mAdc Control Wiring using Multiple Actuators.

INSTALLATION

Inspection

Inspect the carton for possible damage. If damaged, notify the appropriate carrier immediately. If undamaged, open the package and inspect the device for obvious damage. Return damaged products.

Requirements

- Job wiring diagrams
- Tools (not provided)
 - Socket wrench 1/2 inch, used for universal mounting clamp nuts
 - Open-end wrench 10 mm, used for installing AM-676 universal shaft extension
 - Slotted screwdriver, used for installing anti-rotation brackets
 - Allen wrench 3/16", used for manual override
- Appropriate accessories
 - Water tight 1/2 inch conduit seals Invensys part number TF-711-02 or T&B #5332 (straight, Invensys part number TF-713-02 or T&B #5352 (90°), or equivalent.
 - Water tight 1/2 inch flexible conduit (e.,g. Anaconda: Sealtight) or 20 mm flexible water tight conduit when using AM-756 metric conduit adapter with appropriate metric water tight seals.
 - Water tight 1/2" flexible conduit (Anaconda: Sealtight) or 20 mm flexible water tight conduit when using AM-756 metric conduit adapter
 - Two #8 1/2" (13 mm) sheet metal screws for mounting anti-rotation bracket (optional)
- Training: Installer must be a qualified, experienced technician

Precautions

General



Warning: Electrical shock hazard! Contact with live circuits can result in severe injury or death.

- Disconnect the power supply (line power) at the breaker or fuse before and during installation to prevent electric shock and equipment damage.
- Make all connections in accordance with the wiring diagram and in accordance with national and local electrical codes. *Use copper conductors only.*

Failure to observe these warnings can result in severe injury or death and can damage the equipment.



Caution: Avoid electrical noise interference and follow ambient temperature ratings.

- Avoid locations where excessive moisture, corrosive fumes, explosive vapors, or vibration are present.
- Avoid electrical noise interference. Do not install near large contactors, electrical machinery, or welding equipment.
- Dura Drive Actuators are intended for indoor use only. Locate where ambient temperatures do not exceed 140 °F (60 °C) or fall below -25 °F (-32 °C) and relative humidity does not exceed 95% or fall below 15%, non-condensing.

Failure to observe these precautions can damage the equipment.

Federal Communications Commission (FCC)

Note: This equipment has been tested and found to comply with the limits for a Class B digital device, pursuant to Part 15 of the FCC Rules. These limits are designed to provide reasonable protection against harmful interference in residential installations. This equipment generates, uses, and can radiate radio frequency energy and may cause harmful interference if not installed and used in accordance with the instructions. Even when instructions are followed, there is no guarantee that interference will not occur in a particular installation. If this equipment causes harmful interference to radio and television reception—which can be determined by turning the equipment off and on—the user is encouraged to try to correct the interference by one or more of the following measures:

- Reorient or relocate the receiving antenna.
 - Increase the separation between the equipment and receiver.
 - Connect the equipment to an outlet on a circuit different from that to which the receiver is connected.
 - Consult the dealer or an experienced radio/television technician for help.
-

Canadian Department of Communications (DOC)

Note: This class B digital apparatus meets all requirements of the Canadian Interference-Causing Equipment Regulations.

Cet appareil numérique de la classe B respecte toutes les exigences du Règlement sur le matériel brouilleur du Canada.

European Standard EN 55022



Caution: This is a class B (European Classification) product. In a domestic environment this product may cause radio interference in which case the user may be required to take adequate measures.

Failure to observe this precaution can damage the equipment.

Location



Caution: Prevent water damage.

- To maintain NEMA Type 4 or IP56 rating, use water tight 1/2" flexible conduit only, with 1/2" conduit connector of the water tight type T&B #5332 (straight), T&B #5352 (90°), or equivalent.
- For metric conduit applications using AM-756 conduit adapters, use the appropriate metric water tight seals to maintain compliance with IP56 or NEMA Type 4 rating.
- Use a water tight 1/2" pipe plug in any unused actuator conduit ports and seal with water tight tape to stay in compliance with NEMA Type 4 or IP56 rating. Use Invensys part number X-5521, Grinnell #8700159257 (black), Grinnell #8700159851 (galvanized), or equivalent. Actuators with unused conduit ports are shipped with the unused port plugged.

Failure to observe these precautions can damage the equipment.

Mounting

Mount the DuraDrive Actuator directly on the damper shaft in locations that clear the maximum dimensions of the actuator case and allow the actuator to be mounted flush to the surface of the terminal box and perpendicular to the damper shaft.

Note: Some terminal boxes have sheet metal screw heads or other protrusions near the damper shaft. In these cases, a spacer or shim may be added under the mounting tab of the actuator to make the actuator perpendicular to the shaft.

Damper Actuator Sizing

Correct sizing of the actuator is necessary for proper control of dampers. The area of damper that can be controlled by a given actuator is dependent upon the type of damper, the quality of the damper, the pressure drop across the damper in the closed position, and the velocity of the air flow through the damper. To obtain actual damper torque requirements, contact the damper manufacturer.

Damper Shaft Sizing

Use the "Long Damper Shaft" mounting instructions if the damper shaft is at least 4-5/8" (117 mm) long.

Use the "Short Damper Shaft" mounting instructions if the damper shaft is shorter than 4-5/8" or the area around the damper shaft is too narrow to allow standard mounting, as described in the "Long Damper Shaft" mounting section. See Figure-9 for minimum shaft length.

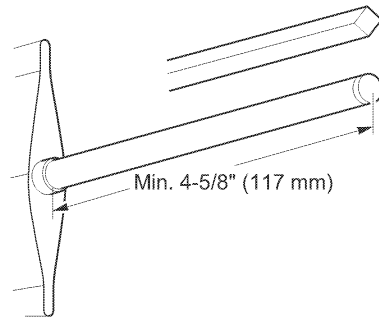

Figure-9 Long Damper Shaft Dimensions.



Caution: The MS41-634X actuator is not designed to be used on aluminum damper shafts, solid steel shafts smaller than 1/2" diameter round or 1/2" square, or hollow steel shafts smaller than 3/4" round. The actuator can produce up to 600 in-lbs (64 N-m) maximum stall torque, which could result in the actuator snapping off an aluminum damper shaft or an improperly sized steel damper shaft. Refer to Table-2 for nominal damper shaft sizes. Failure to observe this precaution can damage the equipment.

Table-2 Steel Damper Specifications.

Damper Shaft Shape	Damper Shaft Type	O.D. (Nominal) ^a	I.D. (Maximum)
Round	Solid bar	1/2" to 1"	0
	Hollow tubing	3/4"	3/8"
		13/16"	11/16"
		27/32"	5/8"
		7/8"	13/16"
		15/16"	13/16"
		1"	29/32"
Square	Solid bar	1/2" to 5/8"	0

^a Damper shaft sizes over 1/2" (13 mm) O.D. require AM-753 universal mounting clamps.

Mounting the Actuator for Clockwise or Counterclockwise Dampers

The zero (0) position on the position indicator is the normal or spring return position. When the actuator is mounted with the “R” side facing the installer and the control signal increases the actuator will rotate in the counterclockwise direction. When the actuator is mounted with the “L” side facing the installer and the control signal increases the actuator will rotate in the clockwise direction.

Long Damper Shafts

1. Move the damper to its normal position. Verify the controller action is set to match the damper application. See TYPICAL APPLICATIONS (wiring diagrams).
 - If the damper shaft rotates clockwise to the closed position, mount the actuator with the side marked “R” facing the installer. See Figure-10.
 - If the damper shaft rotates counterclockwise to the closed position, mount the actuator with the side marked “L” facing the installer. See Figure-11.

Note: The actuator comes equipped with two AM-754 universal mounting clamps. For damper shafts larger than 1/2" (13 mm) in diameter, the AM-753 universal mounting clamps are required (order separately). The AM-753 clamps will accommodate round shaft sizes ranging from 3/4" to 1" (19 to 25 mm) or 5/8" (16 mm) square shafts.

2. Slide the actuator over the shaft and into its desired final mounting position. See Figure-10 or Figure-11.
3. Hand tighten the nuts on both of the actuator’s universal mounting clamps.
4. Align the actuator at 90° (perpendicular) to the damper shaft. See Figure-12.
5. Slide the anti-rotation bracket pin into the mounting slot on the actuator and drill mounting holes. See Figure-12. For narrow spaces, the AM-752 anti-rotation bracket is recommended (order separately).
6. Attach one side of the anti-rotation bracket to the mounting surface with one of the screws provided. Leave the screw loose so that the bracket can be rotated.
7. Pivot the anti-rotation bracket away from the actuator. See Figure-10 or Figure-11.
8. Loosen the universal mounting clamps, making sure not to move the damper shaft. Rotate the actuator approximately 5° in the direction which would open the damper. See Figure-10 or Figure-11.
9. Tighten all of the universal mounting clamp nuts with a 1/2" socket wrench. Apply 4 to 6 ft-lbs (5 to 8 N-m) of torque.
10. Manually rotate the actuator toward the full-closed position to apply pressure to the damper seals. See Figure-10 or Figure-11.
11. Pivot the anti-rotation bracket into place and secure the other side of the bracket onto the mounting surface using the other screw provided with the actuator. See Figure-10 or Figure-11.
12. Verify that the damper is in its full-closed position and actuator at 90° (perpendicular) to the damper shaft. See Figure-10 or Figure-11.

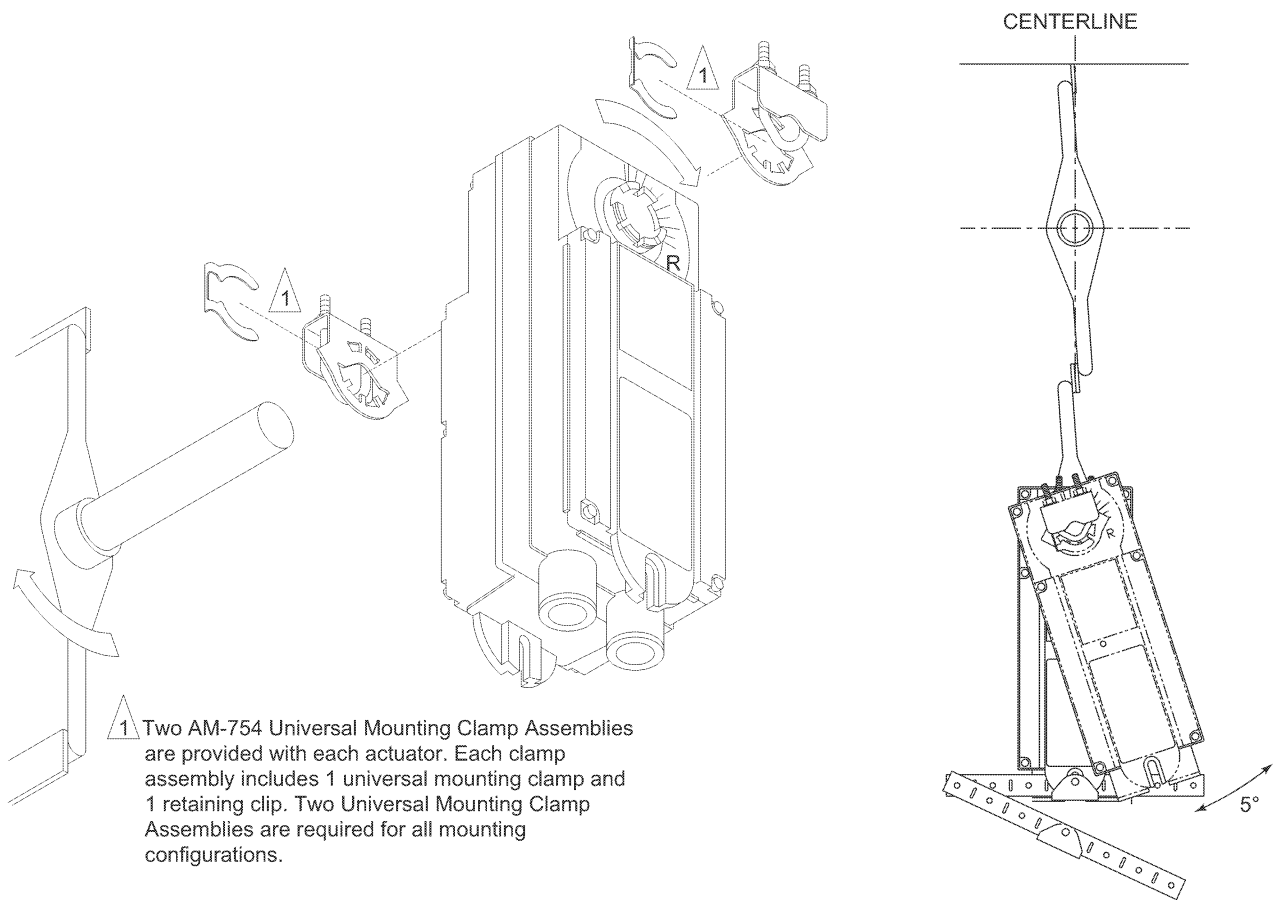

Figure-10 Long Damper Shaft Mounting and Actuator Parts Identification, Actuator Rotation Clockwise to Closed.

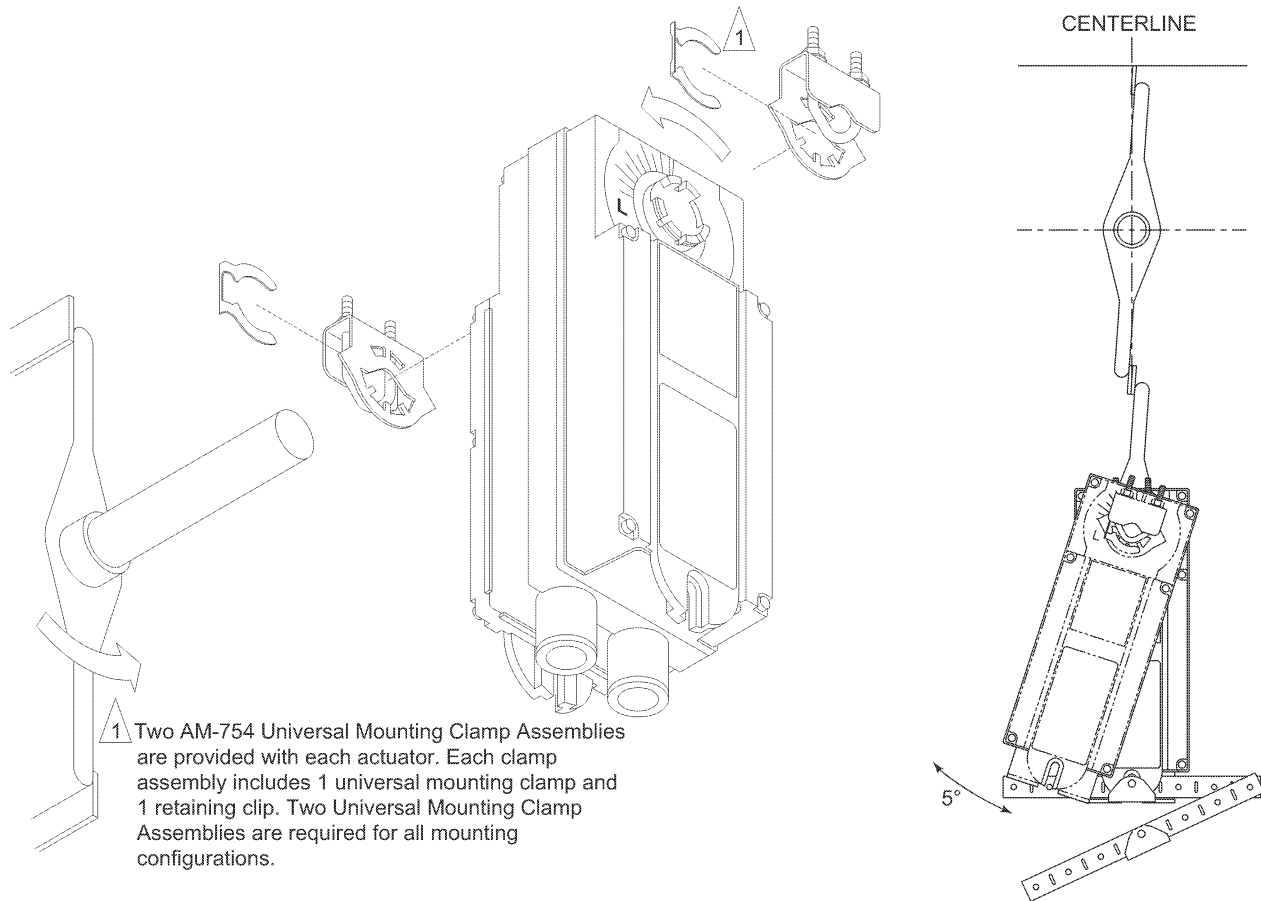

Figure-11 Long Damper Shaft Mounting and Actuator Parts Identification, Actuator Rotation Counterclockwise to Closed

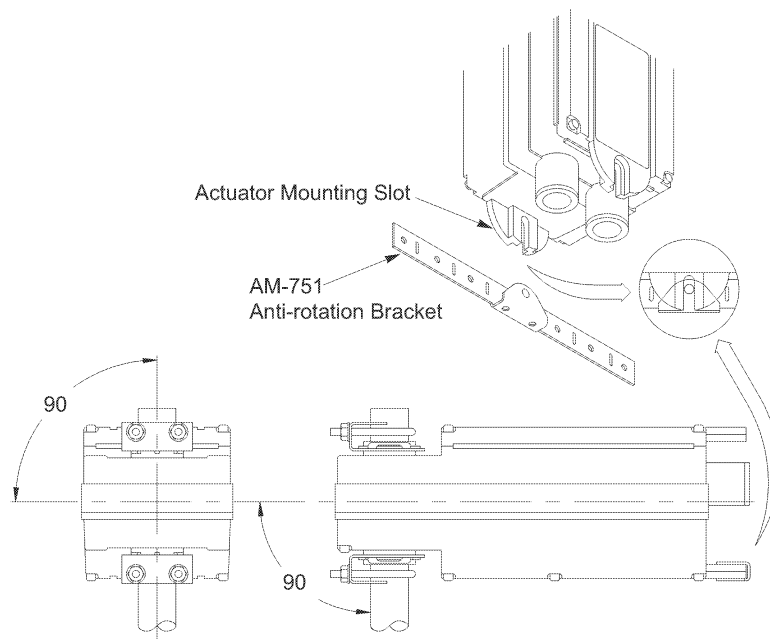

Figure-12 Mounting Anti-rotation Bracket to Actuator.

Short Damper Shafts

See Figure-13 for installation of actuator using the AM-676 Universal Shaft Extension. Installation requires AM-676 Universal Shaft Extension and AM-753 Universal Mounting Clamps for 3/4" to 1" (19 to 25 mm) shafts, these items must be ordered separately.

1. Loosen the V-clamp nuts on the AM-676 universal shaft extension.
2. Fit the universal shaft extension fully onto the damper shaft. Tighten the universal shaft extension V-clamp nuts with a 10 mm open-end wrench. Apply 4 to 6 ft-lbs (5 to 8 N-m) of torque.
3. Move the damper to the closed position. Verify the controller action is set to match the damper application.
4. Remove the mounting clamps from the actuator and replace them with the AM-753 universal mounting clamps.
5. Loosen the nuts on both of the AM-753 universal mounting clamps on the damper actuator.
6. Assemble the damper actuator onto the universal shaft extension, allowing the extension to slide through the actuator's universal mounting clamps. Make sure the actuator is 90° (perpendicular) to the damper shaft. Then, hand tighten the nuts on both of the actuator's universal mounting clamps. See Figure-13.

Note: If the universal shaft extension protrudes excessively above the damper actuator's top universal mounting clamp:

- remove the damper actuator from the universal shaft extension,
- remove the extension from the damper shaft,
- shorten the universal shaft extension by cutting it to the desired length,
- the proceed to follow mounting instructions.

-
7. Slide the anti-rotation bracket pin into the mounting slot on the actuator. See Figure-12. For narrow spaces, the AM-752 anti-rotation bracket is recommended (order separately).
 8. Position the actuator and bracket in the desired final mounting position on the mounting surface and drill mounting holes. See Figure-13.
 9. Attach one side of the anti-rotation bracket to the mounting surface with one of the screws provided. Leave the screw loose so that the bracket can be rotated. See Figure-10 or Figure-11.
 10. Pivot the anti-rotation bracket away from the actuator. See Figure-10 or Figure-11.
 11. Loosen the universal mounting clamps, making sure not to move the damper shaft. Rotate the actuator approximately 5° in the direction which would open the damper. See Figure-10 or Figure-11.
 12. Tighten all of the universal mounting clamp nuts with a 1/2" socket wrench. Apply 4 to 6 ft-lbs (5 to 8 N-m) of torque.
 13. Manually rotate the actuator toward the full-closed position to apply pressure to the damper seals. See Figure-10 or Figure-11.
 14. Pivot the anti-rotation bracket into place and secure the other side of the bracket onto the mounting surface using the other screw provided with the actuator. See Figure-10 or Figure-11.
 15. Verify that the damper is in its full-closed position and actuator at 90° (perpendicular) to the damper shaft. See Figure-13.

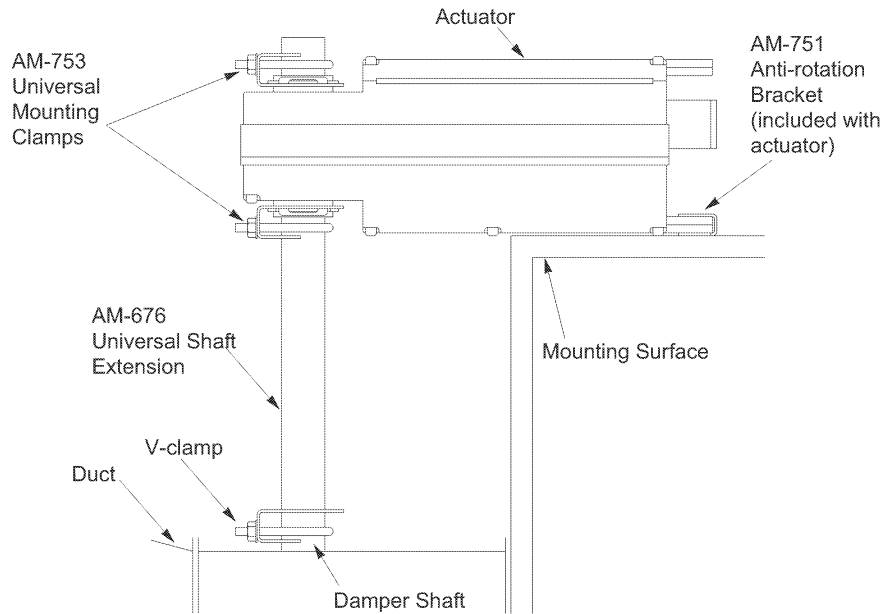

Figure-13 Installation of Universal Shaft Extension.

Wiring Requirements



Control and Power Leads

Remove blue plastic thread protectors before installing conduit fittings. See Figure-1 through Figure-8 for typical wiring applications and Table-3 for maximum wire lengths.

Caution: This product contains a half-wave rectifier power supply and must not be powered by transformers used to power other devices utilizing non-isolated full-wave rectifier power supplies. Refer to *EN-206 Guidelines for Powering Multiple Full-Wave and Half-Wave Rectifier Devices from a Common Transformer*, F-26363, for further information. Failure to observe this precaution can damage the equipment.

Note: Class 2 control and power lead wiring must be routed separately from line voltage wiring and any other non-class 2 circuits.

Table-3 Control and Power Wiring Data.

Actuator Voltage ^a	Part Number	Maximum Wire Run in ft. (m) (5% Voltage Drop)		
		14 AWG	16 AWG	18 AWG
24 Vac	MS41-6343	1190 (363)	748 (228)	471 (144)

^a For 120 Vac and 240 Vac, consult local electrical code.

ADJUSTMENTS

Manual Override



Caution: Avoid physical damage to the actuator.

- Only use Manual Override when the actuator drive motor is not powered.
- Engaging the manual override when the actuator is powered will cause damage to the gears.
- Using power tools to adjust the override will cause damage to the gears.

Failure to observe these precautions can damage the equipment.

Note: Avoid manually repositioning the actuator beyond its adjustable travel limit setting.

The MS41-634X actuator can be manually positioned to ease installation or for emergency positioning. See Figure-14.

1. Insert the 3/16" allen wrench into the hexagon hole located on the label side of the actuator. An illustration, located on the label, shows the location.
2. To engage manual override press and hold inward on the wrench while turning it in the direction shown on the label. It will take approximately 114 revolutions to rotate the full 93° of rotation.
3. Manual override is automatically disengaged by applying power to the drive open or drive closed, see Figure-14. The actuator automatically disengages the override function and goes to the controller's desired position.

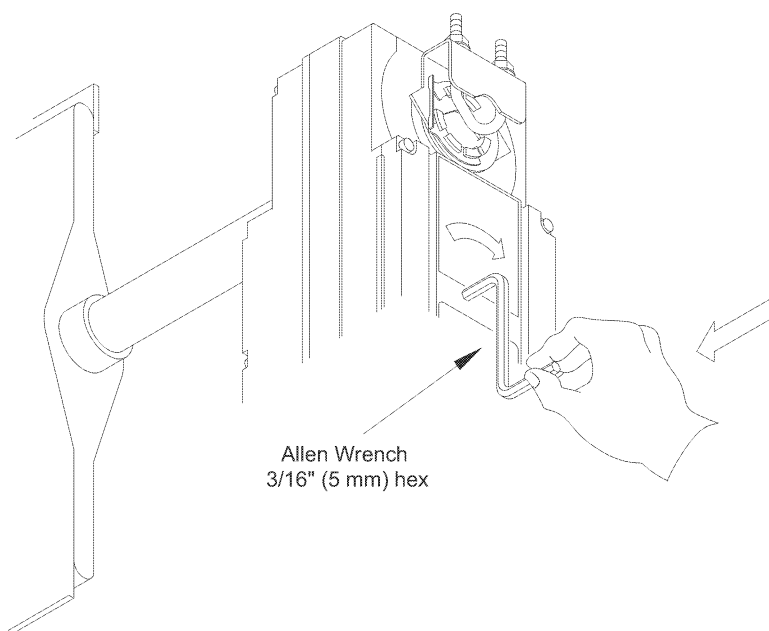

Figure-14 Manual Override Positioning.

CHECKOUT

After the entire system has been installed and the actuator has been powered up, the following check can be made for proper system operation. Check for correct operation of the damper while actuator is being stroked.

Check Stroke

1. Remove power from actuator.
2. Insert a 3/16" allen wrench into the hexagon hole located on the label side of the actuator. An illustration, located on the label, shows the location.
3. Cycle the actuator its full 93° stroke (open/close) and verify that the damper travels through its complete range. To engage manual override press and hold inward on the wrench while turning it in the direction shown on the label.

Operational Check

This procedure is for checking out an actuator that is typically mounted unpowered. It is possible to mount the actuator with power applied for special applications.

1. Apply power to the actuator and control system.
2. Set the controller to cause the actuator to drive open.
3. Check to see that the actuator travels to the full-open position.
4. Set the controller to cause the actuator to drive closed.
5. Check to see that the actuator travels to the fully closed position.

Note: If anticipated damper operation does not occur, verify the Long Damper Shaft or Short Damper Shaft mounting procedures. Also, verify that the controller has the proper action (direct or reverse) to match the damper required operation.

THEORY OF OPERATION

The actuator is, by means of dual mounting clamps, directly mounted onto the damper shaft. The anti-rotation bracket supplied with the actuator prevents lateral movement of the actuator. The damper actuator is not provided with and does not require, any limiting switches, but is electronically protected against overloading.

The angle of rotation is electronically limited to $93^{\circ} \pm 1^{\circ}$. When reaching the damper or actuator end position, the motor stops automatically. The gears can be manually positioned when power is not available to the actuator. Insert the allen wrench into the recessed hexagon socket on the actuator cover and push the wrench inward while turning. The position of the actuator is indicated by means of scale reading 0 to 95°.

MAINTENANCE

Regular maintenance of the total system is recommended to assure sustained optimum performance. The MS41-634X actuator is maintenance free.

FIELD REPAIR

None. Replace with functional actuator.

DIMENSIONAL DATA

Figure-15 dimensions are in inches (mm).

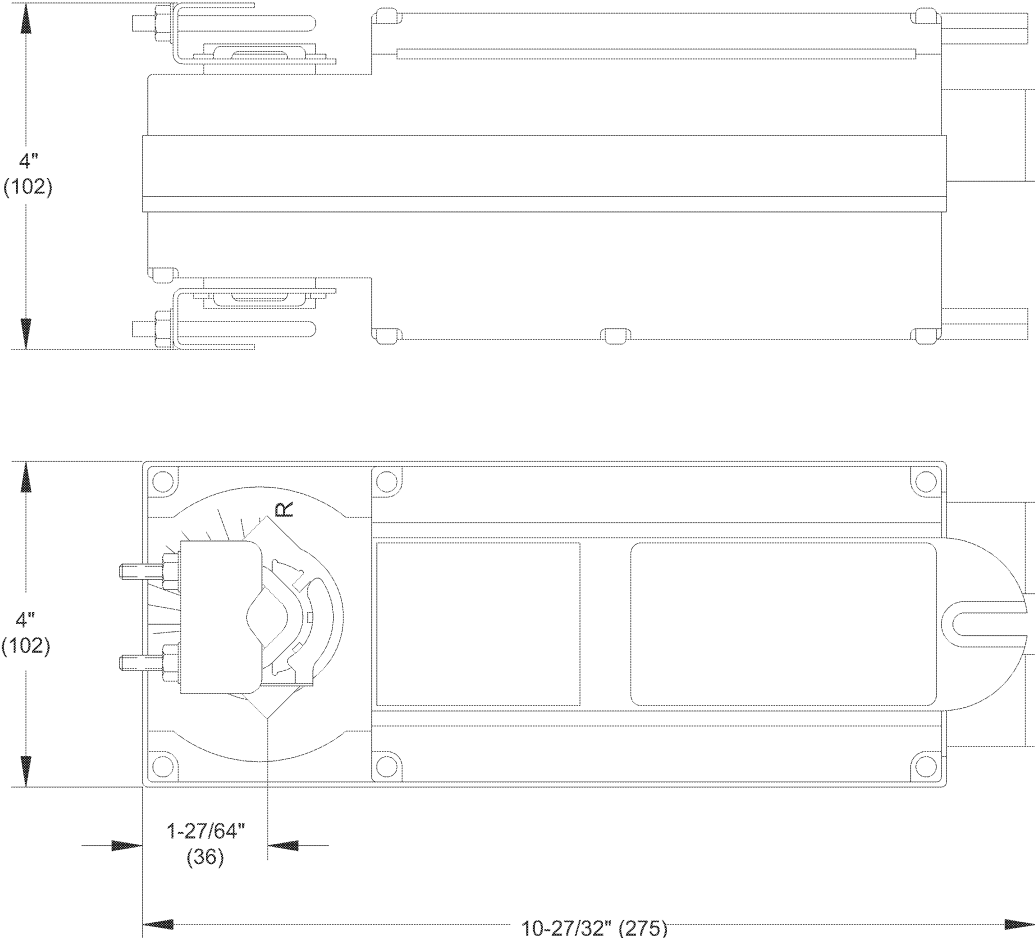

Figure-15 MS41-634X Damper Actuator.

Invensys and DuraDrive are trademarks of Invensys plc and its subsidiaries and affiliates.