

DuraDrive™ Series
35 lb-in. Spring Return Actuators
Mounting and Wiring Instructions

Requirements

- Job wiring diagrams
- Tools and hardware (not provided):
 - #8 sheet metal screws (for universal bracket)
 - 10mm open end wrench or socket wrench
 - 7/16 inch, open end wrench or socket wrench
 - 1/8 inch, allen wrench
 - Appropriate screwdriver(s)
- Appropriate accessories
- Training: Installer must be a qualified, experienced technician

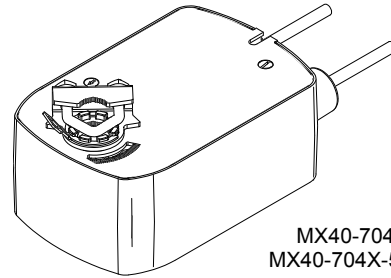

Additional Information

See the list of applicable General Instructions, on page 8.

Precautions



Warning:

- Electrical shock hazard! Disconnect the power supply (line power) before installation to prevent electric shock and equipment damage.
- Make all connections in accordance with the job wiring diagram and in accordance with national and local electrical codes. *Use copper conductors only.*

Caution: Do not drill additional holes in the actuator body. Three pre-drilled holes are located on each side, under the label, to accept #10-24 thread-forming screws for mounting accessories (Figure-12).

TYPICAL APPLICATIONS (wiring diagrams)

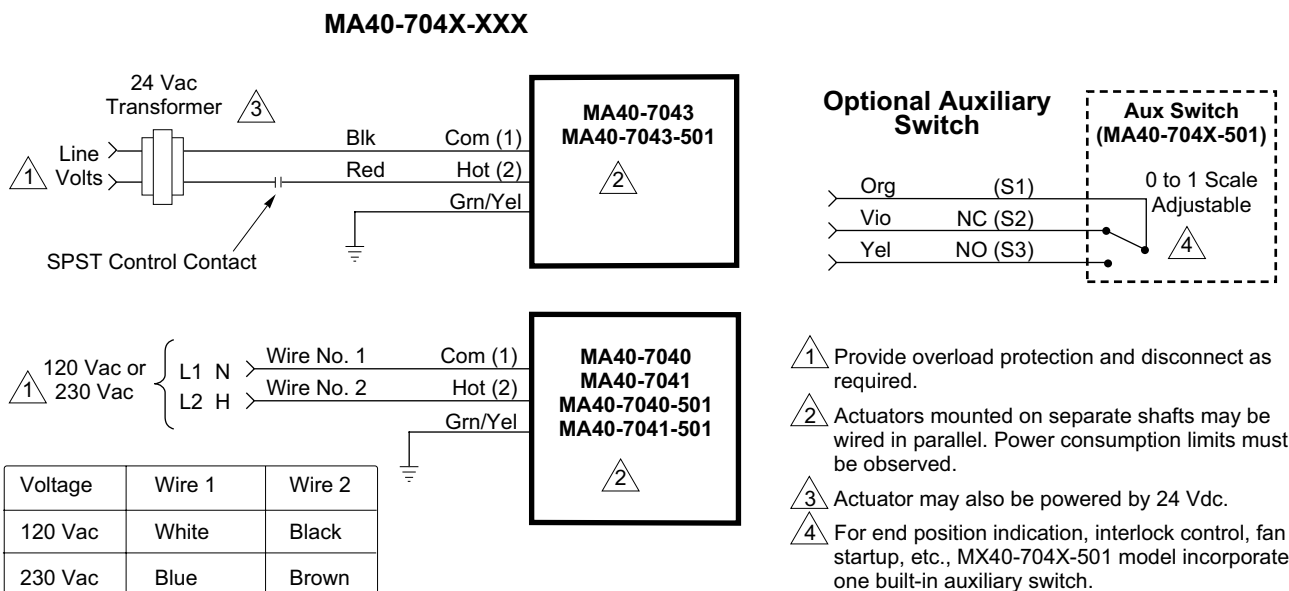

Figure-1 Typical Wiring Diagram for Two-Position Basic and Single Auxiliary Switch Models.

MF40-7043-XXX

Caution: This product contains a half-wave rectifier power supply. It must not be powered with transformers that are used to power other devices utilizing non-isolated full-wave rectifier power supplies. Refer to *EN-206, Guidelines for Powering Multiple Devices from a Common Transformer, F-26363* for detailed information.

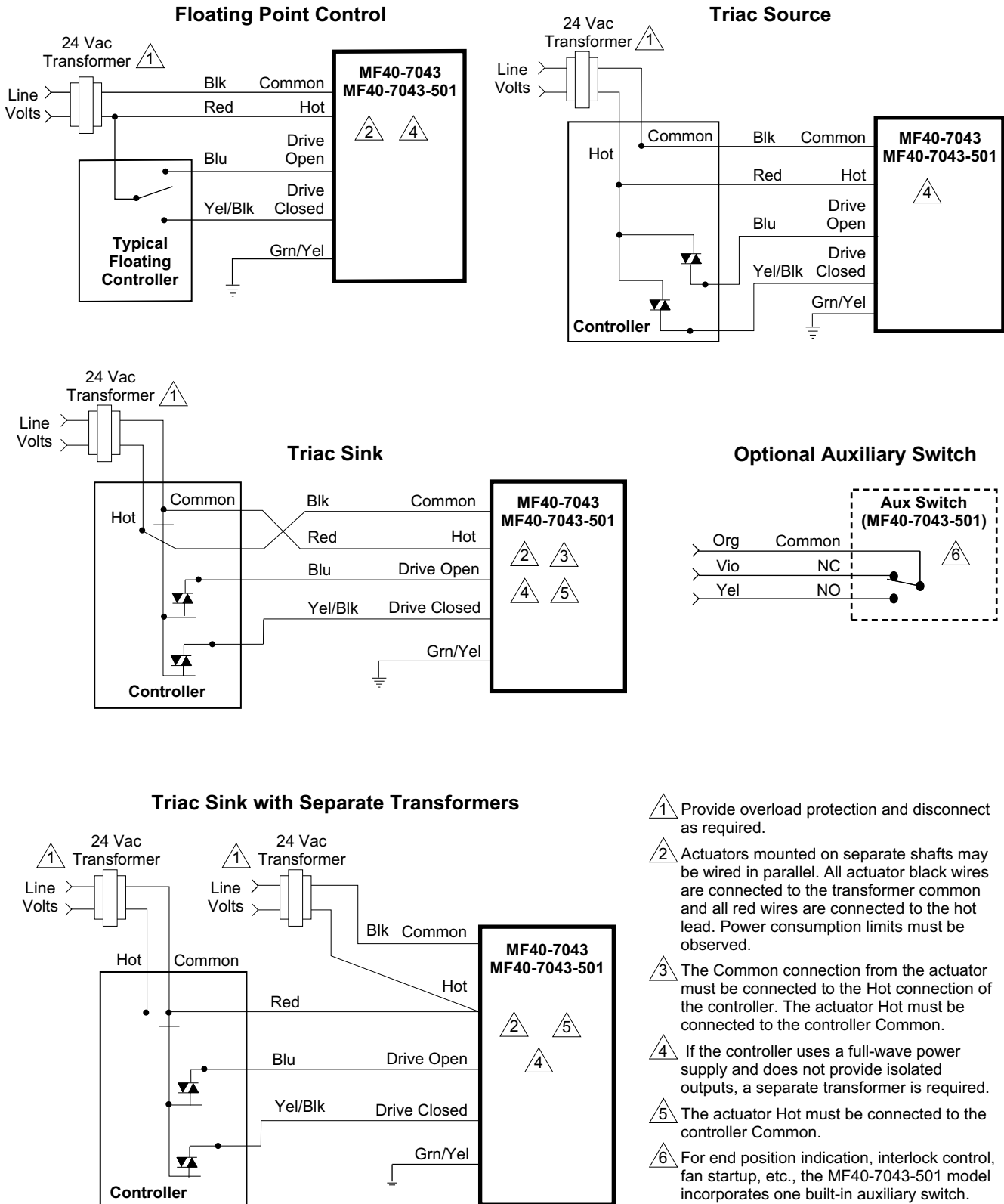
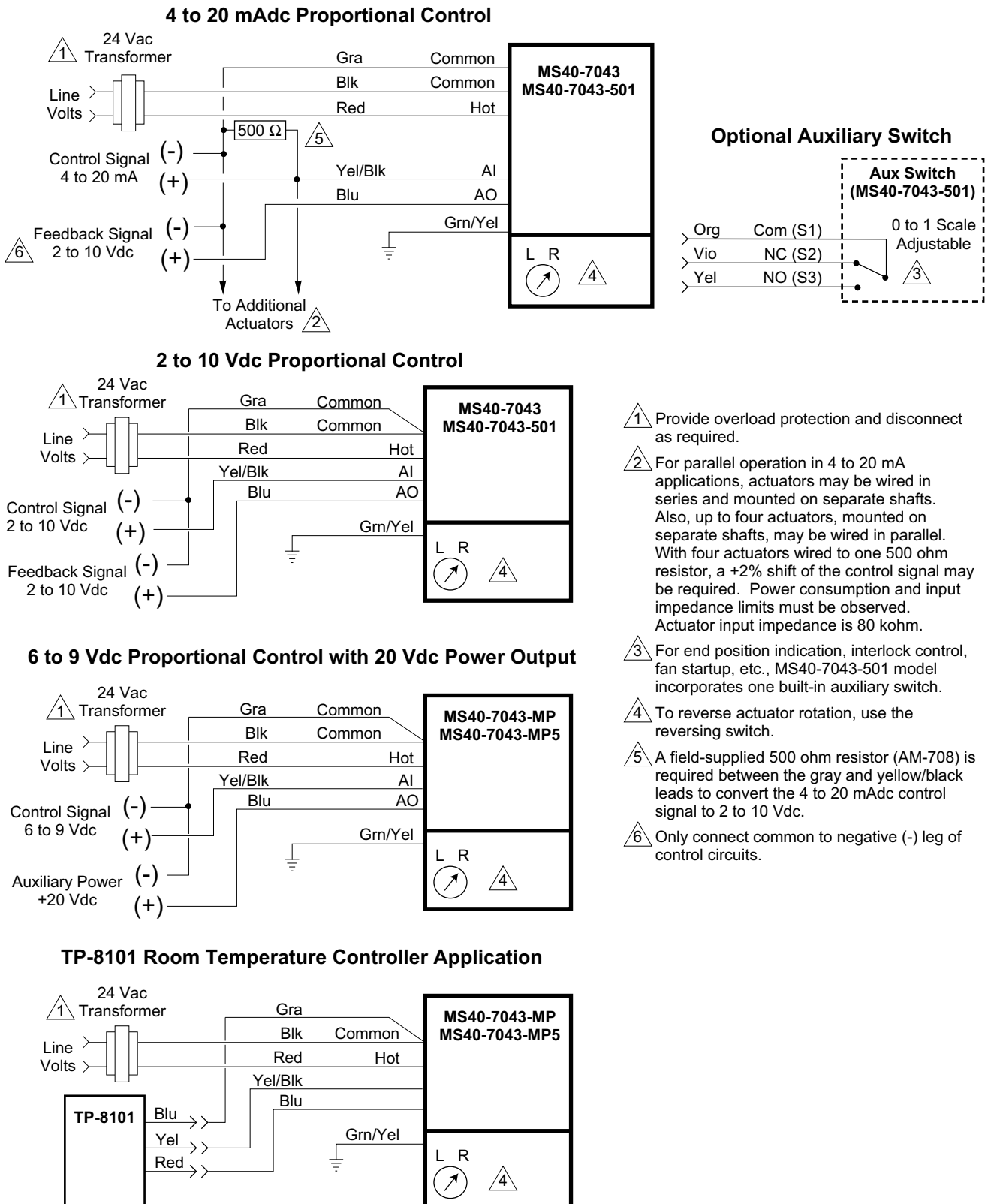

Figure-2 Typical Wiring Diagrams for Floating Control 24 Vac Basic and Single Auxiliary Switch Models.

MS40-7043-XXX

Caution: This product contains a half-wave rectifier power supply. It must not be powered with transformers that are used to power other devices utilizing non-isolated full-wave rectifier power supplies. Refer to *EN-206, Guidelines for Powering Multiple Devices from a Common Transformer, F-26363* for detailed information.



- 1 Provide overload protection and disconnect as required.
- 2 For parallel operation in 4 to 20 mA applications, actuators may be wired in series and mounted on separate shafts. Also, up to four actuators, mounted on separate shafts, may be wired in parallel. With four actuators wired to one 500 ohm resistor, a +2% shift of the control signal may be required. Power consumption and input impedance limits must be observed. Actuator input impedance is 80 kohm.
- 3 For end position indication, interlock control, fan startup, etc., MS40-7043-501 model incorporates one built-in auxiliary switch.
- 4 To reverse actuator rotation, use the reversing switch.
- 5 A field-supplied 500 ohm resistor (AM-708) is required between the gray and yellow/black leads to convert the 4 to 20 mAdc control signal to 2 to 10 Vdc.
- 6 Only connect common to negative (-) leg of control circuits.

Figure-3 Proportional Control and TP-8101 Room Temperature Controller Application of MS40-7043-XXX Series Actuator.

Mounting

MX40-704X Series Long Shaft Installation

Refer to Figure-4 for shaft dimensions, and to Figure-5 through Figure-8 for mounting.

Caution: Do not drill additional holes in the actuator body. Three pre-drilled holes are located on each side, under the label, to accept #10-24 thread-forming screws for mounting accessories (Figure-12).

Note: The MX40-704X series actuator comes equipped with standard universal mounting clamp. For damper shafts larger than 5/8" (16 mm) in diameter, the AM-710 universal mounting clamp is required (order separately). The AM-710 clamp accommodates shaft sizes up to 3/4" (19 mm) diameter.

1. The universal clamp must be attached to the actuator by the retaining clip (Figure-5).
2. Position the damper at its normal (spring return) position. Verify the damper is fully closed or completely open.
3. Slide the actuator over the shaft and verify that the position indication pointer on the universal clamp is in the normal spring return position (Figure-6). Tighten the universal clamp, finger tight only.
4. Align the universal bracket at the base of the actuator and drill mounting holes. Bend the bracket as needed to reach the duct (Figure-7).
5. Place a #8 sheet metal screw in one side of the universal bracket (anti-rotation bracket) and mount it to the duct at the base of the actuator. Do not tighten the screw.
6. Pivot the universal bracket away from the actuator.
7. Loosen the universal clamp, making sure not to move the damper shaft. Rotate the actuator approximately 5° in the direction which would open the damper (Figure-8).
8. Tighten the universal clamp to the damper shaft. Make sure the universal clamp is in the correct mounting position (Figure-6).
9. Manually rotate the actuator to align with universal bracket (Figure-6) and (Figure-8).
10. Pivot the universal bracket into place and secure both sides (Figure-8).
11. Tighten all fasteners. Tighten the two nuts on the clamp, using a wrench to apply 4 to 6 ft-lb (5.4 to 8.2 N-m) of torque.

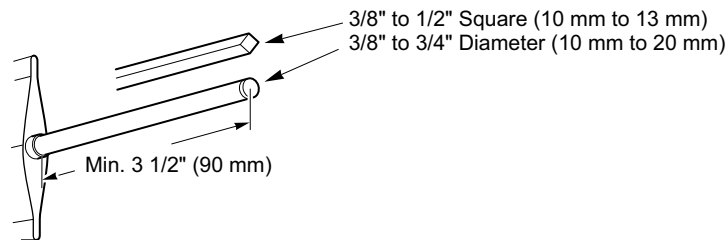

Figure-4 Long Damper Shaft Dimensions.

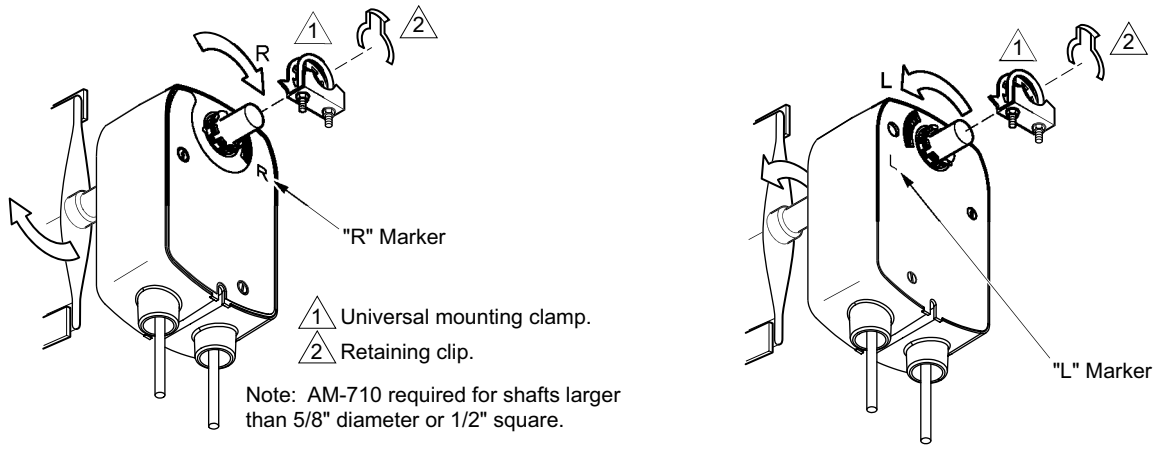

Figure-5 Long Damper Shaft with Clockwise or Counterclockwise Spring Return.

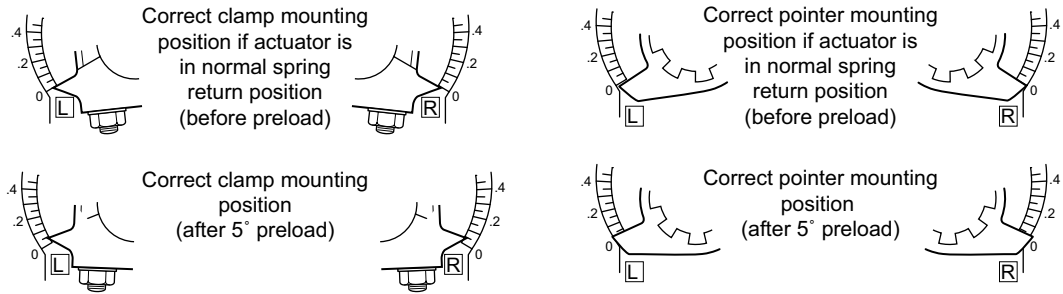

Figure-6 Universal Clamp and AM-709 Pointer (optional) Positions Indicating Normal Spring Return and Pre-load Settings for the MX40-704X Series.

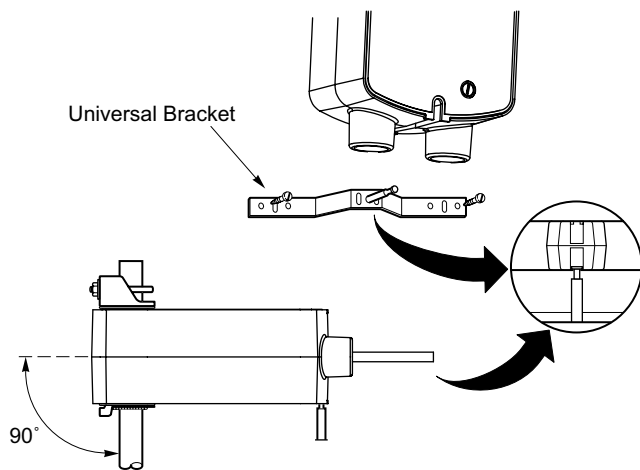

Figure-7 Mounting Universal Bracket to Actuator.

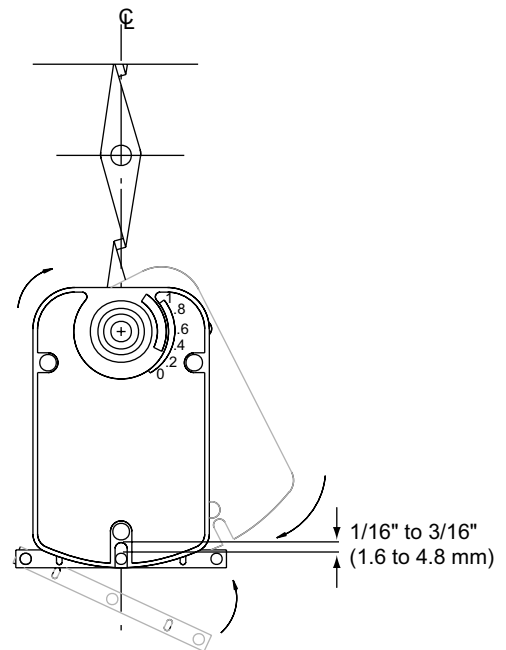

Figure-8 Anchoring the Actuator with the Universal Bracket.

MX40-704X Series Short Shaft Installation

Refer to Figure-9 for shaft dimensions, and to Figure-10 for mounting.

Caution: Do not drill additional holes in the actuator body. Three pre-drilled holes are located on each side, under the label, to accept #10-24 thread-forming screws for mounting accessories (Figure-12).

Note: The MX40-704X series actuator comes equipped with a standard universal mounting clamp. For damper shafts larger than 5/8" (16 mm) in diameter, the AM-710 universal mounting clamp is required (order separately). The AM-710 clamp accommodates shaft sizes up to 3/4" (19 mm) diameter.

1. Determine the best orientation for the universal clamp on the back of the actuator. The best orientation provides the easiest access to the two nuts on the V-clamp (Figure-10).
2. Engage the clamp to the actuator as close as possible to the determined location.
3. Lock the clamp in place using the remaining retainer clip.
4. Place the position indicator on the actuator and secure it with the retainer clip. Make sure the position indicator is at its before pre-load position (Figure-10).
5. Position the damper at its normal (spring return) position. Verify the damper is fully closed or completely open.
6. Slide the actuator over the shaft and verify that the position indicator is pointing to the normal spring return position (Figure-6). Tighten the universal clamp, finger tight only.
7. Align the universal bracket (anti-rotation bracket) at the base of the actuator and drill mounting holes. Bend the bracket as needed to reach the duct. Attach the bracket to the duct with #8 sheet metal screws (Figure-7).
8. Place a screw in one side of the universal bracket and mount it at the base of the actuator. Do not tighten the screw.
9. Pivot the universal bracket away from the actuator (Figure-8).
10. Loosen the universal clamp, making sure not to move the damper shaft. Rotate the actuator approximately 5° in the direction which would open the damper (Figure-8).
11. Tighten the universal clamp to the shaft.
12. Manually rotate the actuator to align with universal bracket (Figure-6 and Figure-8).
13. Pivot the universal bracket into place and secure both sides (Figure-8).
14. Tighten all fasteners. Tighten the two nuts on the clamp, using a wrench to apply 4 to 6 ft-lb (5.4 to 8.2 N-m) of torque.

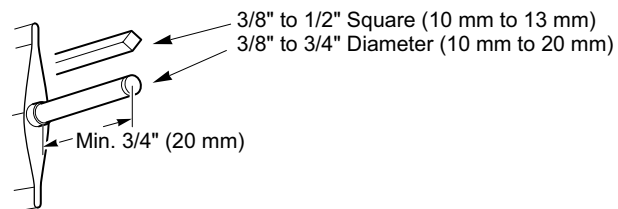

Figure-9 Short Damper Shaft Dimensions.

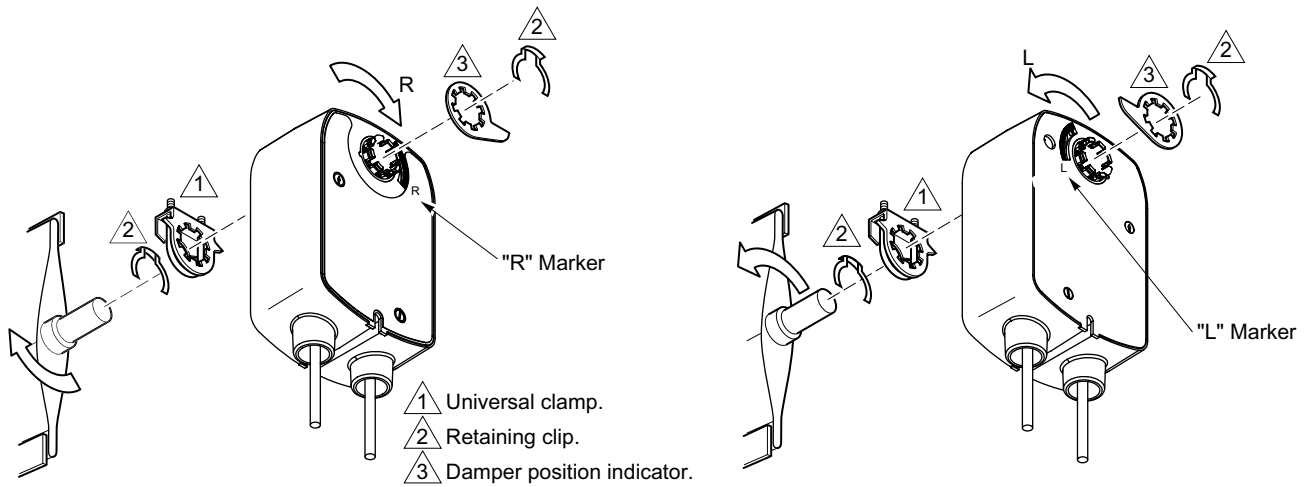

Figure-10 Short Damper Shaft with Clockwise or Counterclockwise Spring Return.

Rotation Limitation

Rotation Limitation for MX40-704X Series

Note: Limiting the rotation of the actuator also reduces the system throttling range. Be sure to adjust the controller's throttling range accordingly.

The Stop Block is used in conjunction with the tab on the universal clamp or the AM-709 position indicator. In order to function properly, the clamp or indicator must be mounted correctly.

The Stop Block controls the rotational output of the MX40-704X actuators. It is used in applications where a damper has a designed rotation that is less than 90°, for example with a 45° or 60° rotating damper.

1. Determine the amount of damper rotation required. The actuator stop block provides limited rotation from 40° to 95°.
2. Loosen the screw securing the stop block to the actuator.

Note: The actuator is shipped with the Stop Block installed on the "L" side. If the damper application requires that the "R" side faces the installer, simply remove the Stop Block and its mounting screw, and move it to the new location.

3. Slide the stop block into position, so that its edge lines up with the degree graduation on the actuator face which corresponds with the required rotation. See (Figure-11).
4. Secure the stop block in place.
5. Test the damper rotation by applying power. Re-adjust if necessary.

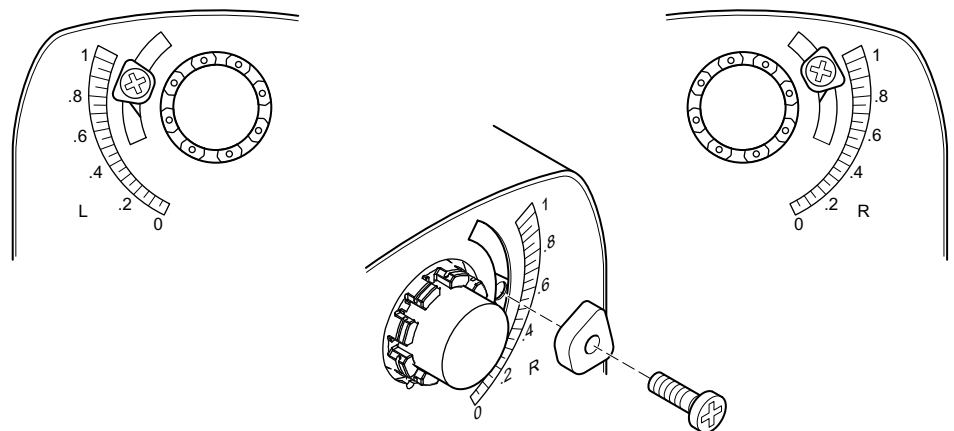

Figure-11 Adjusting Stop Block for Limited Rotation.

DIMENSIONAL DATA

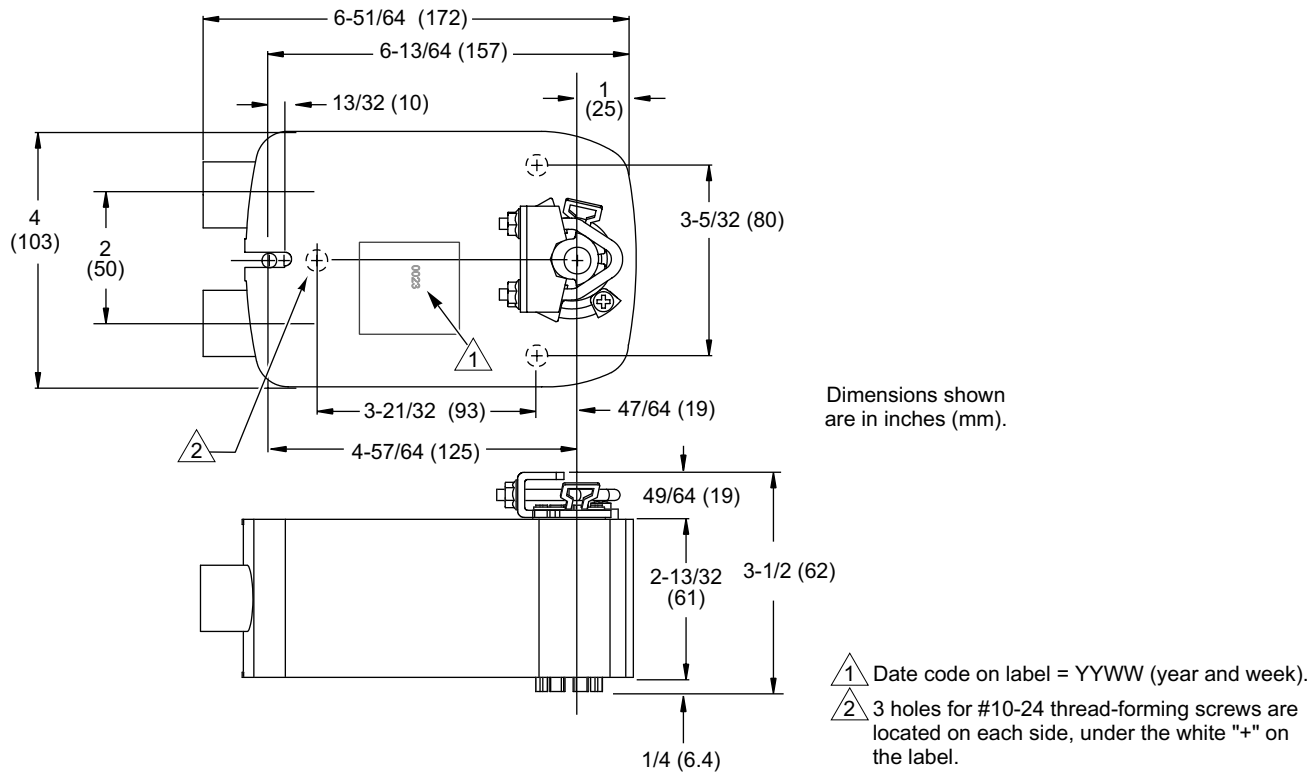

Figure-12 MX40-704X Series Mounting Dimensions.

General Instructions

For more detailed installation information, refer to the following documents:

F-Number	Description
F-26642	MA40-704X, MA40-707X, and MA40-715X Series DuraDrive Spring Return Two-Position Actuators General Instructions
F-26644	MF40-7153 and MF40-70X3 Series DuraDrive Spring Return Floating Actuators General Instructions
F-26645	MS40-7043, MS40-7073, and MS40-7153 Series DuraDrive Spring Return Proportional Actuators General Instructions

Part Number Cross Reference

This cross reference lists Invensys DuraDrive Actuators by part number. The obsolete part numbers are listed alphanumerically in the left-hand column, while the corresponding new part numbers are given in the right-hand column.

Old DuraDrive Part Number	New DuraDrive Part Number	Old DuraDrive Part Number	New DuraDrive Part Number
MA40-LF120	MA40-7040	MA40-LF24-501	MA40-7043-501
MA40-LF120-501	MA40-7040-501	MF40-LF24	MF40-7043
MA40-LF230	MA40-7041	MF40-LF24-501	MF40-7043-501
MA40-LF230-501	MA40-7041-501	MS40-LF24	MS40-7043
MA40-LF24	MA40-7043	MS40-LF24-501	MS40-7043-501