



Invensys Building Systems
 1354 Clifford Avenue (Zip 61111)
 P.O. Box 2940
 Loves Park, IL 61132-2940
 United States of America

General Instructions

DuraDrive™ Electric Damper Actuators

MS41-6043/MS41-6083 Series

Non-spring Return Rotary

24 Vac - Modulating Control 0 to 10 Vdc



Description

The DuraDrive direct coupled 24 Vac non-spring return rotary electric actuators are designed for modulating control of dampers.

Features

- Compact, lightweight design
- Self-adapting capability for maximum flexibility in damper positioning
- Manual override
- 5° preload as shipped from factory
- Offset and slope adjustment models available
- Independently adjustable dual auxiliary switches available
- cUL and UL listed; CE certified

Application

These actuators are used in constant or variable air volume installations for control of HVAC dampers requiring up to 35 lb-in (4 Nm) torque or 70 lb-in (8 Nm).



Product Numbers

Table 1.

Torque	Cabling	24 Vac Operating Voltage			
		Standard	Slope/Offset Adjustable	Dual Auxiliary Switches and Slope/Offset Adjustable	Dual Auxiliary Switches Only
35 lb-in (4 Nm)	Plenum	MS41-6043	MS41-6043-520	MS41-6043-522	MS41-6043-502
70 lb-in (8 Nm)		MS41-6083	MS41-6083-520	MS41-6083-522	MS41-6083-502

Warning/Caution Notations

WARNING:		Personal injury or loss of life may occur if you do not follow a procedure as specified.
CAUTION:		Equipment damage or loss of data may occur if you do not follow a procedure as specified.

Specifications	Operating voltage (G–G0)	24 Vac +20%, –15%	
	Frequency	50/60 Hz	
Power Supply	Power consumption	Running: 3.3 VA Holding: 1.2 VA	
	Input signal (Y-G0)		
Control Signal	Voltage-input	0 to 10 Vdc	
	Input resistance	100K ohms	
Feedback Signal	Position output signal (U–G0)		
	Voltage-output	0 to 10 Vdc	
	Maximum output current	DC 1 mA	
Equipment Rating	Rating	Class 2 according to UL, cUL Class III per EN60730	
Auxiliary Features	Control signal adjustment		
	Offset (start point)	Between 0 and 5 Vdc	
	Slope (span)	Between 2 and 30 Vdc	
	Dual auxiliary switch contact rating		
	AC rating	24 Vac 4A resistive, 2A inductive	
	DC rating	12 to 30 Vdc DC 2A	
	Switch Range		
	Switch A	0° to 90° with 5° intervals	
	Recommended range usage	0° to 45°	
	Factory setting	5°	
	Switch B	0° to 90° with 5° intervals	
	Recommended range usage	45° to 90°	
	Factory setting	85°	
Switching hysteresis	2°		
Function	Torque		
	MS41-6043 Series	35 lb-in (4 Nm)	
	MS41-6083 Series	70 lb-in (8 Nm)	
	Runtime for 90° opening or closing		
	MS41-6043 Series	90 seconds. at 60 Hz (108 seconds at 50 Hz)	
	MS41-6083	125 seconds at 60 Hz (150 seconds at 50 Hz)	
Nominal angle of rotation	90°		
Maximum angular rotation	95°		
Mounting	Shaft size: Minimum shaft length 3/4-inch (20 mm)		
			
	EA1010R1 3/8 to 5/8 inch 8 - 16 mm	1/4 to 1/2 inch 6 - 12.7 mm	9/16 inch 15 mm
	Figure 1. Acceptable Shaft Sizes.		
Housing	Enclosure	NEMA Type 2 IP54 according to EN60529	
	Material	Durable plastic	
	Gear lubrication	Silicone-free	

Specifications, Continued

Ambient Conditions

Ambient temperature

Operation
Storage and transport

-25°F to 130°F (-32°C to 55°C)
-40°F to 158°F (-40°C to 70°C)

Voltage Requirements for 6083 Series at High Temperatures:

Minimum Voltage: 24 Vac +20%, -10%
90°F to 130°F (32°C to 55°C)

Ambient humidity (non-condensing)

95% rh

Agency Certification

UL 873
cUL certified to Canadian Standard C22.2 No. 24-93

CE Conformity

Electromagnetic Compatibility (EMC)
Emissions standards
Immunity standards

89/336/EEC
EN 50081-1
EN 50082-2

Miscellaneous

Pre-cabled connection
Cable length
Life cycle
Dimensions
Weight

18 AWG
3 feet (0.9 m)
Five-year warranty
See Figure 13
1.06 lbs (0.48 kg)

Actuator Components

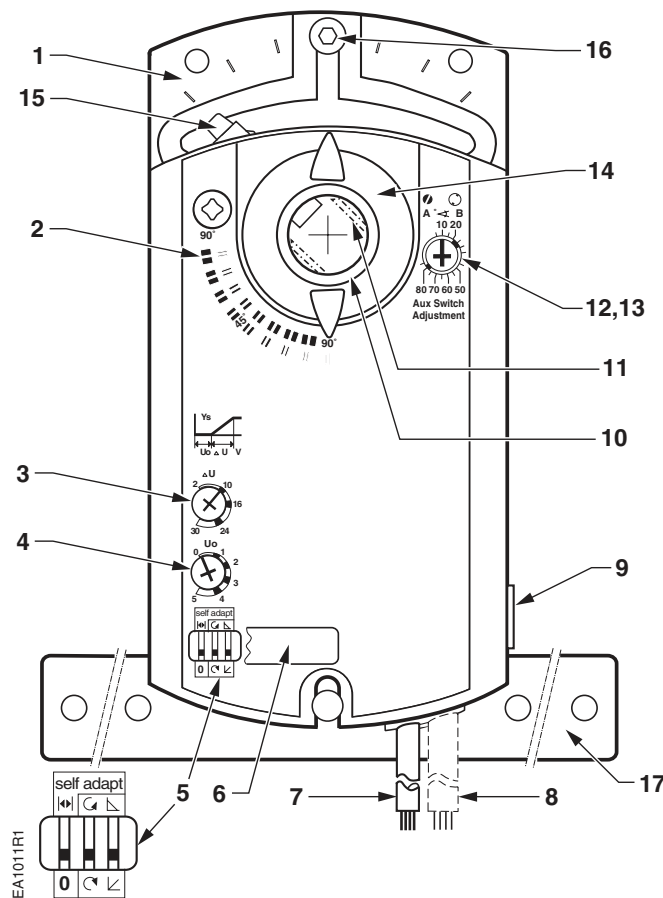

Legend

1. Base plate
2. Positioning scale for angle of rotation
3. Slope adjustment
4. Offset (start point) adjustment
5. DIP switches
6. Cover for DIP switches
7. Connection cables
8. Connection cables
9. Manual override
10. Coupling bushing
11. 1/2-inch guide
12. Auxiliary switch A
13. Auxiliary switch B
14. Position indicator
15. Adjustment lever with locking screw (3 mm hex)
16. Set screw for mechanical range stop (3 mm hex)
17. Anti-rotation bracket

Figure 2. Parts of the Actuator.

Operation

A continuous 0 to 10 Vdc signal from a controller to wire 8 (Y) operates the damper actuator. The angle of rotation is proportional to the control signal. A 0 to 10 Vdc position feedback output signal is available between wire 9 (U) and wire 2 (G0) to monitor the position of the damper motor.

In the event of a power failure, the actuator holds its position. In the event that only the control signal is lost, the actuator returns to the "0" position.

Life expectancy

An improperly tuned loop will cause excessive repositioning that will shorten the life of the actuator.

Control signal adjustment

MS41-6043-520/MS41-6083-520 and MS41-6043-522/MS41-6083-522: For sequencing and the electronic limitation of the angle of rotation.

Use the U_o potentiometer to set the offset (start point) between 0 to 5 Vdc.
Use the ΔU potentiometer to set the slope (span) between 2 to 30 Vdc.

NOTE: The Y input is limited to a maximum of 10 Vdc. If the sum of the offset and slope setting is greater than 10V, the angle of rotation is reduced providing the feature of electronic limitation of the angle of rotation.

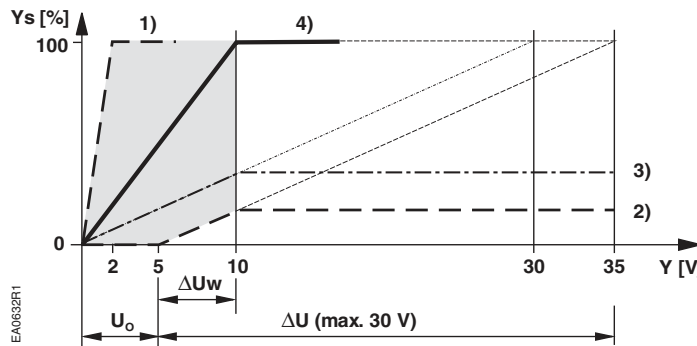
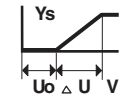
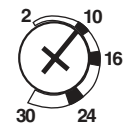

Figure 3.

Y_s Actuator position (100% = angle of rotation 90°*)
Y Control input signal
 U_o Offset (start point)
 ΔU Slope
 ΔU_w Active voltage range (Y_s changes)



SLOPE, ΔU



OFFSET, U_o

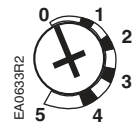

Setting for
10V slope
0 Vdc offset

Figure 4.

* When the mechanical limitation of the angle of rotation and self-adapt function are ON, 100% does not equal 90°.

Table 2.

Examples in Figure 3	U_o Offset	ΔU Slope	Active Voltage Range	Y_s Actuator Position
1. Minimum slope	0 Vdc	2 Vdc	0 to 2 Vdc	0 to 100%
2. Limitation of rotation	5 Vdc	30 Vdc	5 to 10 Vdc	0 to 16.7%
3. Limitation of rotation	0 Vdc	30 Vdc	0 to 10 Vdc	0 to 33.3%
4. Setting shown in Figure 4	0 Vdc	10 Vdc	0 to 10 Vdc	0 to 100%

Operation, Continued

Control signal adjustment example:

Determine the setting needed to electronically limit the angle of rotation between 0 to 50% (0 to 45°) using a 2 to 10 Vdc input.

Calculating the value of ΔU :

$$\Delta U = \frac{100[\%]}{\text{working angle of rotation } Y_s[\%]} \times (10[Vdc] - U_o[Vdc]) = \frac{100\%}{50\%} \times (10Vdc - 2Vdc) = 16Vdc$$

Settings: $U_o = 2 Vdc$;
 $\Delta U = 16 Vdc$

Electronic limitation
angle of rotation $Y_s = 50\% (45^\circ)$
Slope $\Delta U = 16V$
Active voltage range $\Delta U_w = 2 \text{ to } 10 Vdc$

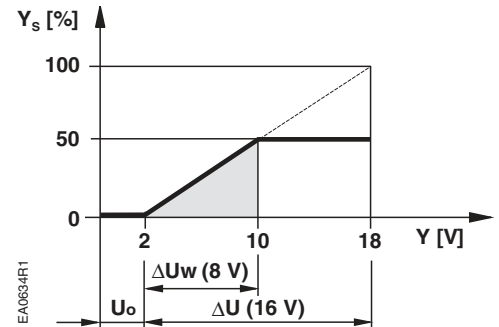

Figure 5. Example.

Dual Auxiliary Switch

MS41-6043-502
MS41-6043-522
MS41-6083-502
MS41-6083-522

Figure 6 shows the adjustable switching values for the auxiliary switches A and B.

Actuator Scale:
clockwise

Adjustment range for
Switches A and B
Setting interval: 5°
Switching hysteresis:
2°

Actuator Scale:
counterclockwise

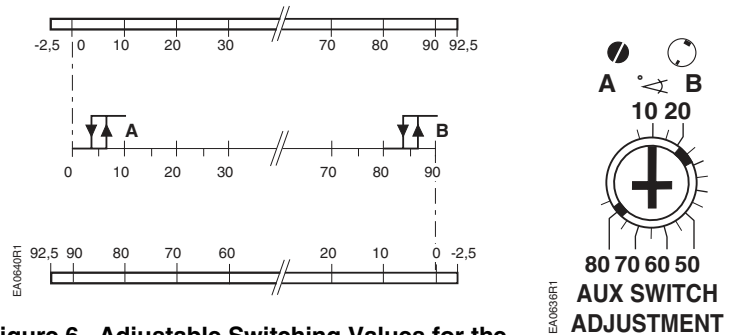

Figure 6. Adjustable Switching Values for the dual auxiliary Switches.

NOTES:

- The auxiliary switch setting shafts rotate with the actuator. The scale is valid only when the actuator is in the "0" position on clockwise motion.
- For the counterclockwise rotation, the adjustment lever has to move from 90° to 0° by using the manual override and then adjust the auxiliary switches. After the auxiliary switches are adjusted, the adjustment lever has to move back to the 90° position.
- Use the long arm of the X to point to the position of switch A. Use the narrower tab on the red ring to point to the position of switch B.

Dual in-line package (DIP) switches

Raise the protective cover from left to right to locate the DIP switches. See Figure 2 for the location of the cover.

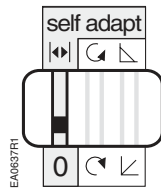



Figure 7.
Self-adapt
Switch.

The factory setting is 0 (OFF).

When mechanical angle of rotation is limited, the self-adapt switch may be turned ON  so that the limited range will become the new 0 to 100% for the actuator logic. In this case, 0 to 100% is not equal to 90°.

CAUTION:



When turning the self-adaptive feature on or after a software reset with the feature on, the actuator will enter a five-minute calibration cycle as the actuator adjusts to the rotation limits of the system. A software reset happens after power on or may be caused by electrostatic discharge (ESD) at levels of 2kV and above.

The position output signal U is not influenced by the self-adapt function. The 0 to 10V feedback signal U is always proportional to 0 to 90° (or 90 to 0°).

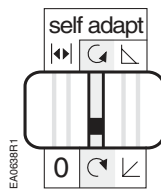

Figure 8.
Direction of
Rotation Switch.

The factory setting is clockwise.

The direction of rotation switch should match the damper rotation movement.

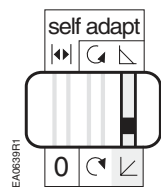

Figure 9.
Output Signal
Switch.

The factory setting is direct acting.

As the clockwise angle of rotation increases, the output voltage increases.

If the direction of rotation is counterclockwise, the output signal switch should be set at reverse acting to match the direction of the rotation switch.

Sizing

The type of actuator required depends on several factors.

1. Obtain damper torque ratings (ft-lb/ft² or Nm/m²) from the damper manufacturer.
2. Determine the area of the damper.
3. Calculate the total torque required to move the damper:

$$\text{Total Torque} = \frac{\text{Torque Rating} \times \text{Damper Area}}{\text{SF}^1}$$

¹Safety Factor: When determining the torque of an actuator required, a safety factor should be included for unaccountable variables such as slight misalignments, aging of the damper, etc. A suggested safety factor is 0.80 (or 80% of the rated torque).

4. Select the actuator type from Table 3.

Table 3.

Total Torque	Actuator
35 lb-in (4 Nm)	MS41-6043 Series
70 lb-in (8 Nm)	MS41-6083 Series

Mounting and Installation

Place the actuator on the damper shaft so that the front of the actuator is accessible. The label is on the front side. An anti-rotation bracket is included with the actuator.

The minimum damper drive shaft length is 3/4-inch (20 mm).

Observe the service envelope around the actuator as shown in Figure 13.

For detailed mounting instructions, see *Installation Instructions F-27211*.

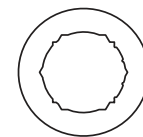
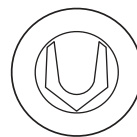

NOTE: For all damper shafts with the exception of the 1/2-inch round shaft: Remove 1/2-inch diameter guide before installation.

Figure 10. Damper Shaft Sizes.

Manual override

To move the damper blades and lock the position with no power present:

1. Slide the red manual override knob toward the back of the actuator.
2. Make adjustments to the damper position.
3. Slide the red manual override knob toward the front of the actuator.

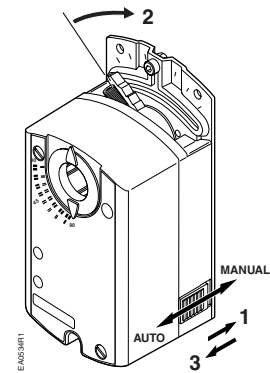

Figure 11. Manual Override.

Once power is restored, the actuator returns to automated control.

Mechanical range adjustment

To mechanically limit the range of the damper blade.

1. Loosen the stop set screw.
2. Move the screw along the track to the desired position, and fasten it in place.

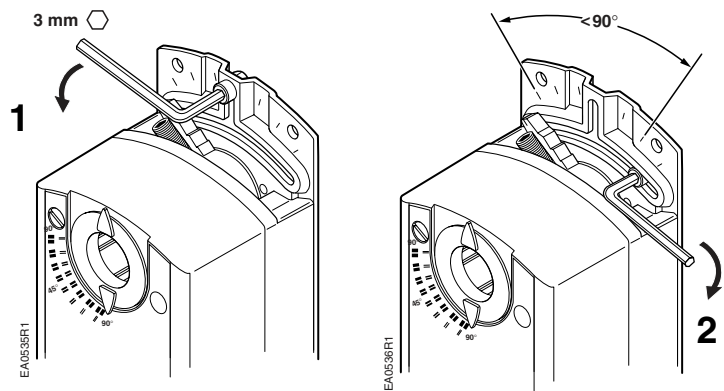

Figure 12. Moving the Mechanical Range Stop.

To use the entire 0 to 10V input signal to control the mechanically limited range: See Figure 7 for setting self-adaptive features.

Example:

Stop set screw at 70°
Self-adapt switch ON
Input signal Y = 5 Vdc

The damper will be at 35° (50% of the adjusted range.)

NOTE: On versions with the slope and offset features, this example assumes
Offset $U_0 = 0$ Vdc
Slope $\Delta U = 10$ Vdc

Wiring

All wiring must conform to NEC and local codes and regulations.

Use earth ground isolating step-down Class 2 transformers. Do not use autotransformers.

The sum of the VA ratings of all actuators and all other components powered by one transformer must not exceed the rating of the transformer.

It is recommended that one transformer power no more than ten actuators.



WARNING:

All six outputs of the dual auxiliary switch (A and B) must only be connected to:

Class 2 voltage (UL/C-UL).

Separated Extra-Low Voltage (SELV) or Protective Extra Low Voltage (PELV) (according to HD384-4-41) for installations requiring CE conformance.



WARNING:

Installations requiring CE Conformance:

- All wiring for CE certified actuators must only be separated extra low voltage (SELV) or protective extra low voltage (PELV) per HD384-4-41.
- Use safety isolating transformers (Class III transformer) per EN61558. They must be rated for 100% duty cycle.
- Overcurrent protection for supply lines is maximum 10A.

Wiring Designations Each wire has the standard symbol printed on it.

24 Vac power supply

0 to 10V modulating control

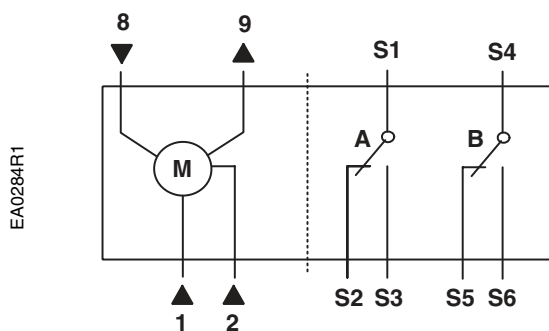

Standard Symbol	Function	Color
1	Supply (SP)	Red
2	Neutral (SN)	Black
8	0 to 10V input signal	Gray
9	Output for 0 to 10 Vdc position indication	Pink
Factory-installed options		
S1	Switch A Common	Black
S2	Switch A N.C.	
S3	Switch A N.O.	
S4	Switch B Common	
S5	Switch B N.C.	
S6	Switch B N.O.	

EA0284R1

Start-Up/ Commissioning

Check that the wires are connected correctly.

Check that offset and slope are set correctly, if used.

Check that the direction of rotation switch matches the rotation of the damper shaft.

Connect wires 1 (red) and 2 (black) to a Digital Multimeter (DMM) with the dial set at AC V to verify that the operating voltage is within range.

1. Check operation:

- a. Connect wires 1 (red) and 2 (black) to the actuator.
 - b. Set the DMM dial to Vdc.
 - c. Connect wires 2 (black) and 8 (gray) to the DMM.
 - d. Apply a full-scale input signal (10 Vdc) to wire 8 (gray).
 - e. Allow the actuator shaft coupling to rotate from 0° to 90°.
 - f. Disconnect wire 8 (gray) and the shaft coupling returns to the "0" position.
- 1.

2. Check Feedback:

- a. Set the DMM dial to Vdc.
- b. Attach wires 2 (black) and 9 (pink) to the DMM.
- c. Apply a full scale input signal to wire 8 (gray).
The reading at the DMM should increase.
- d. Remove the signal from wire 8 (gray).
The reading at the DMM should decrease and the actuator shaft coupling returns to the "0" position.

3. Check Auxiliary Switch A:

- a. Set the DMM dial to ohms (resistance) or continuity check.
 - b. Connect wires S1 and S3 to the DMM.
The DMM should indicate open circuit or no resistance.
 - c. Apply a full scale input signal to wire 8 (gray).
The DMM should indicate contact closure as the actuator shaft coupling reaches the setting of switch A.
 - d. Connect wires S1 and S2 to the DMM. The DMM should indicate open circuit or no resistance.
 - e. Stop the signal to wire 8 (gray).
The DMM should indicate contact closure as the actuator shaft coupling reaches the setting of switch A.
-

**Start-Up/
Commissioning,
Continued**

4. Check Auxiliary Switch B:
 - a. Set the DMM dial to ohms (resistance) or continuity check.
 - b. Connect wires S4 and S6 to the DMM. The DMM should indicate open circuit or no resistance.
 - c. Apply a full scale input signal to wire 8 (gray). The DMM should indicate contact closure as the actuator shaft coupling reaches the setting of switch B.
 - d. Connect wires S4 and S5 to the DMM. The DMM should indicate open circuit or no resistance.
 - e. Stop the signal to wire 8 (gray). The DMM should indicate contact closure as the actuator shaft coupling reaches the setting of switch B.

Service



WARNING:

Do not open the actuator.
If the actuator is inoperative, replace the unit.

Dimensions

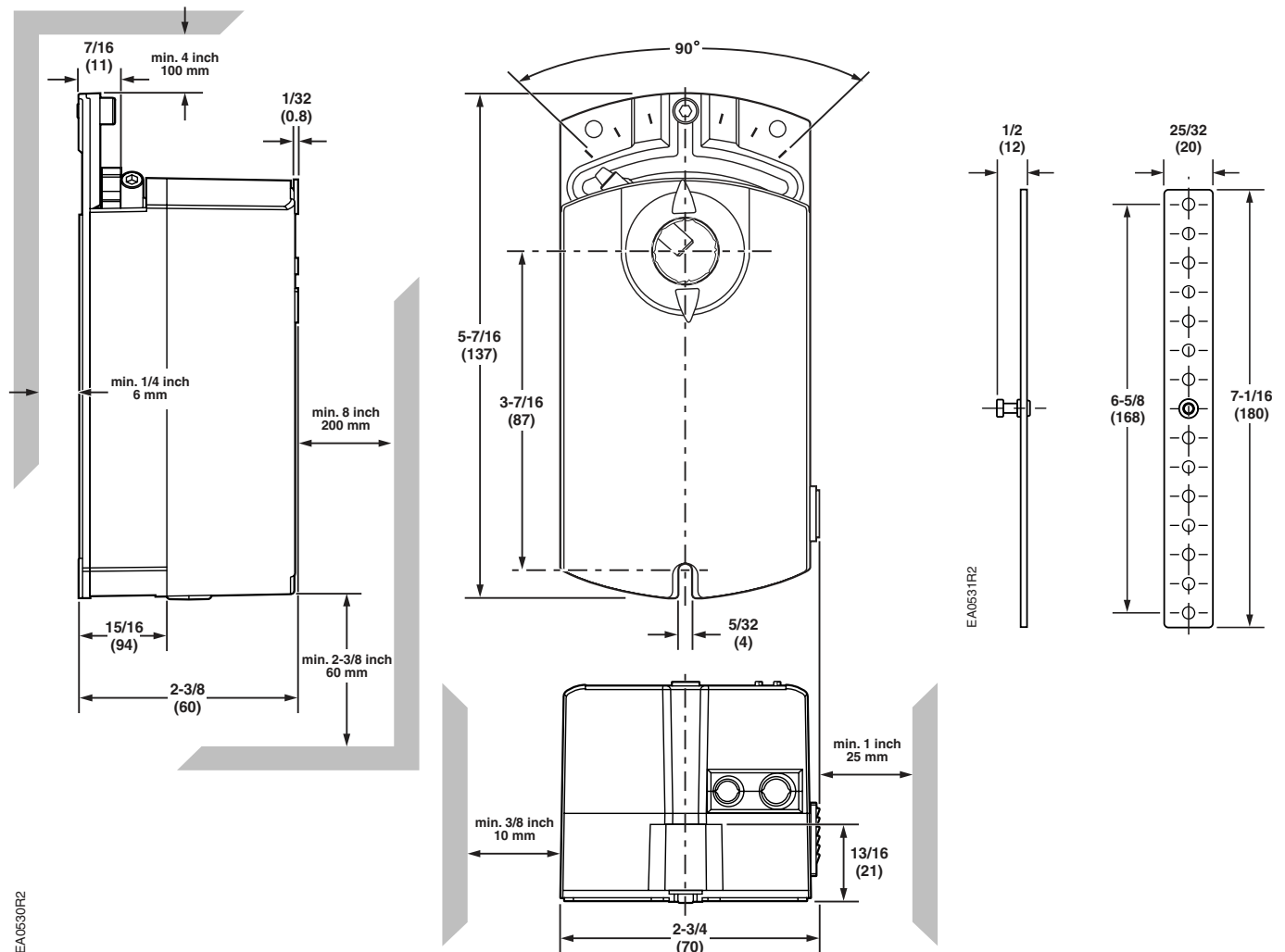

Figure 13. Dimensions of the DuraDrive Actuator and Anti-rotation Bracket.