

Sensors – High Pressure

Series 750B-C3 Chamber with 3 Probes

Series 750B-C4 Chamber with 4 Probes

Specifications Chamber

- NEMA 4X chamber enclosure and listed
- Maximum steam pressure 250 psig (17.6 kg/cm²)
- Designed for use with the Series 750B remote mount control module to make a complete system for level control in a boiler or other vessel. See page 35.

Ordering Information

Model Number	Part Number	Description	Weight lbs. (kg)
750-C-3	176316	Cast iron chamber w/3 probes	26 (11.8)
750-C-4	176317	Cast iron chamber w/4 probes	26 (11.8)

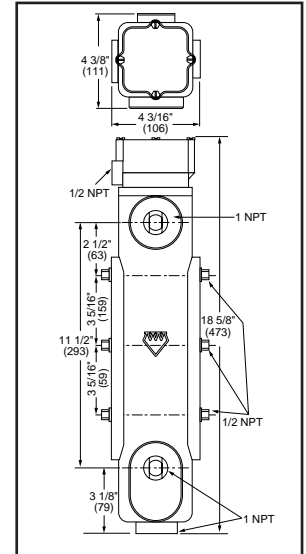

RS-1-HP



Series-RS High Pressure Remote Sensor:

- NEMA 1 Enclosure
- Maximum Temperature 406°F (208°C)
- Maximum Pressure 250 psig (17.6 kg/cm)
- For single sensor applications with high-pressure environments. Requires additional probe rod. See page 85.

Ordering Information

Model Number	Part Number	Description	Weight lbs. (kg)
RS-1-HP	176199	High pressure remote sensor	0.5 (.23)

Dimensions, in. (mm)

Model	A	B	C	D
RS-1-HP Remote Sensor	3/8 NPT	7/8 (22)	3 (80)	3 3/8 (86)

