

## Water Feeders – Make-Up

### Series 847 Make-Up Water Feeder

- For receiver tanks in commercial or industrial applications
- Mounts directly on the receiver, eliminating need for equalizing connections
- Quick-change replaceable cartridge valve and strainer
- Proportional feed action
- Mounting Flange – six  $\frac{7}{16}$ " (11.1mm) bolt holes on a  $5\frac{3}{4}$ " (146mm) bolt circle
- Optional features
  - No. 2 switch
  - Alternate valve orientation
- Maximum supply pressure 150 psi (10.5 kg/cm<sup>2</sup>)
- Maximum inlet water temperature 120°F (49°C)
- Maximum receiver pressure 25 psi (1.8 kg/cm<sup>2</sup>)

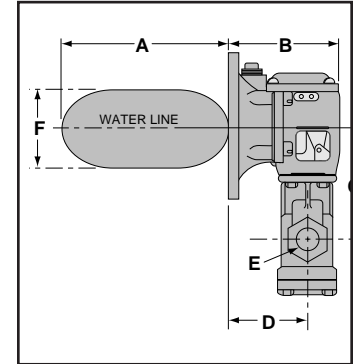

#### Dimensions, in. (mm)

A	B	C	D	E	F
$7\frac{5}{16}$ (186)	$4\frac{15}{16}$ (125)	$4\frac{5}{8}$ (117)	$3\frac{9}{16}$ (90)	$\frac{1}{2}$ NPT	$3\frac{7}{16}$ (87)

#### Ordering Information

Model Number	Part Number	Description	Weight lbs. (kg)
847	134300	Make-up water feeder	11 (5.0)
847-C	134350	847 w/alternate valve orientation	12 (5.4)
847-C-2	134400	847-C w/No. 2 switch	12 (5.4)

#### Capacities

