

Flow Switches – Air

Series AFE-1 Air Flow Switches

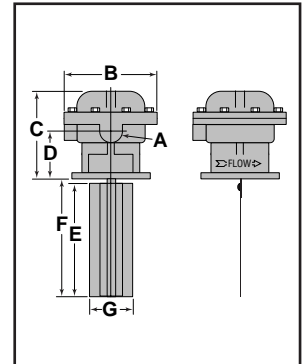

- For industrial hazardous environment applications requiring a **NEMA 7 (Class I, Division I, Group C and D) or NEMA 9 (Class II, Division I, Group E, F, and G)** rated flow switch for medium velocity
- 1/2" NPT conduit connection
- Paddle fits 8" (203mm) minimum duct size
- Brass, steel and aluminum construction
- Single pole, double throw snap switch
- Magnetic switching mechanism eliminates need for bellows
- Sensitivity adjusting screw makes flow adjustment easy
- Maximum ambient temperature 120°F (49°C)
- Maximum duct temperature 275°F (135°C)



Electrical Ratings

Voltage	Motor Switch Rating (Amperes)		Pilot Duty
	Full Load	Locked Rotor	
120 VAC	7.4	44.4	125 VA at 120 or 240 VAC 50 or 60 cycles
240 VAC	3.7	22.2	

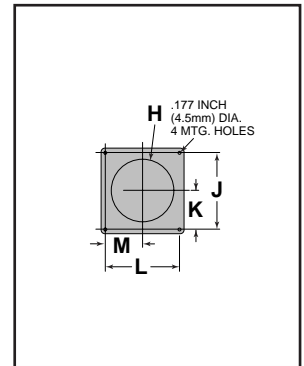

Ordering Information

Model Number	Part Number	Description	Weight lbs. (kg)
AFE-1	123010	Air flow switch w/NEMA 7 & 9 enclosure	6 (2.7)
AFE-1-E	123011	AFE-1-CE conformance rated	6 (2.7)

See page 157 for CE Conformance information

Flow Rates – feet per minute (meters per minute)

Horizontal Duct (Recommended Installation)

Mounting/ Duct	Settings	Mode of Operation	
		Flow fpm (mpm)	No Flow fpm (mpm)
Top (Recommended)	Factory or Minimum	300 (91)	100 (30)
	Maximum	1900 (579)	500 (152)
Side	Factory or Minimum	350 (107)	100 (30)
	Maximum	1950 (594)	900 (274)

Based on Standard Air 0.075 pounds per Cubic Foot (1.205 kg/m³)
Values are ± 10%

Dimensions, in. (mm)

A	B	C	D	E	F
NPT					
1/2	5 3/4 (146)	5 13/32 (137.3)	2 29/32 (74)	7 1/8 (181)	7 1/2 (191)
G	H	J	K	L	M
2 3/4 (70)	3 5/8 (92)	4 3/8 (111)	2 3/16 (56)	4 3/8 (111)	2 13/16 (56)