

E5X SERIES

Versatile Energy Monitoring Solution

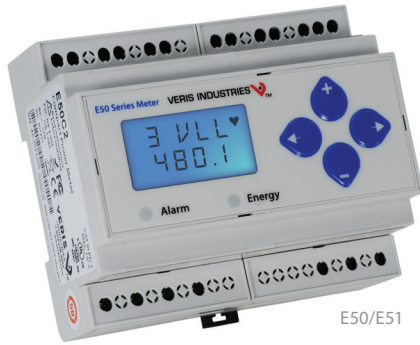

E50/E51

The E5x Series DIN Rail Meter combines exceptional performance and easy installation to deliver a cost-effective solution for power monitoring applications. The E5x can be installed on standard DIN rail or surface mounted as needed. The Modbus and BACnet output models offer added flexibility for system integration. The data logging capability (E5xC3 and E5xx5) protects data in the event of a communications or power failure elsewhere in the system. Combinations of serial communication, pulse output, and phase alarms are provided to suit a wide variety of applications. Additional pulse inputs on E5xHx and E50Fx provide an easy way to incorporate simple flow sensors to track gas, water, steam, or other energy forms using a BACnet or Modbus system.

The E51 models add a bi-directional monitoring feature designed expressly for renewable energy applications, allowing measurement of power imported from the utility grid as well as power exported from the renewable energy source (e.g. solar panels). In this way, a facility administrator can track all energy data, ensuring accuracy in billing and crediting. They are also useful for monitoring loads that use regenerative braking.

SPECIFICATIONS

| INPUTS | |
|---------------------------------|---|
| Control Power, AC | 50/60 Hz; 5 VA max.; 90 V min.; UL Maximums: 600 V _{L-L} (347 V _{L-N}); CE Maximum: 300 V _{L-N} |
| Control Power, DC | 3W max.; UL and CE: 125 to 300 Vdc (external DC current limiting required) |
| Voltage Input | UL: 90 V _{L-N} to 600 V _{L-L} ; CE: 90 V _{L-N} to 300 V _{L-N} |
| CURRENT INPUT | |
| Scaling | 5 A to 32,000 A |
| Input Range | 0 to 0.333 V or 0 to 1 V (selectable) CTs must be rated for use with Class 1 voltage inputs |
| Pulse Inputs E5xHx & E50Fx only | Contact inputs to pulse accumulators (one set with E5xH2; two sets with E5xH5)* |
| ACCURACY | |
| Real Power & Energy | 0.2% (ANSI C12.20, IEC 62053-22 Class 0.2S) |
| OUTPUTS | |
| E50B1 & E5xCx | Real Energy Pulse: N.O. static**; Alarm contacts: N.C. static** |

Revenue grade measurements

Meets ANSI C12.20 Class 0.2 standards

High reliability

ANSI C12.20 0.2% accuracy, IEC 62053-22 Class 0.2S on E5xxx

Easy installation

DIN rail or screw mounting options

Multiple applications

Real energy output and phase loss alarm output on E50Bx and E5xCx models...one device serves multiple applications

Data logging

Ensures long term data retrieval and safeguards during power failures (E5xC3 and E5xx5)

Wide CT compatibility

Compatible with CTs from 5 A to 32000 A

APPLICATIONS

- Energy monitoring in building automation systems
- Renewable energy
- Energy management
- Commercial sub-metering
- Industrial monitoring
- Cost allocation

| | |
|-------|---|
| E50Bx | Reactive energy pulse 30 Vac** |
| E5xCx | RS-485 2-wire Modbus RTU (1200 baud to 38.4 kbaud) |
| E5xHx | RS-485 2-wire BACnet MS/TP (9600 baud to 115.2 kbaud) |

MECHANICAL

| | |
|----------|---------------------------------|
| Mounting | DIN Rail or 3-point screw mount |
|----------|---------------------------------|

ENVIRONMENTAL

| | |
|-----------------------|--|
| Altitude of Operation | 3000 m |
| Operating Temp Range | -30 to 70 °C (-22 to 158 °F) |
| Storage Temp Range | -40 to 85 °C (-40 to 185 °F) |
| Humidity Range | <95% RH non-condensing |
| Mounting Location | Not suitable for wet locations. For indoor use only. |

WARRANTY

| | |
|------------------|---------|
| Limited Warranty | 5 years |
|------------------|---------|

AGENCY APPROVALS

| | |
|------------------|--|
| Agency Approvals | UL 508 (Open Type Device), IEC/EN 61010-1, UKCA (UK), California CSI Solar, ANSI C12.20, Cat III, Pollution Degree 2 |
|------------------|--|



*10 kΩ Vac/dc to 4 to 10 Vdc.

**30 Vac/dc, 100 mA max. (AC: 50/60Hz).



ORDERING INFORMATION

| | E50B1 | E50C2 | E50C3 | E50H2 | E50H5 | E51C2 | E51C3 | E51H2 | E51H5 |
|--|-------|-------|-------|-------|-------|-------|-------|-------|-------|
| MEASUREMENT CAPABILITY - FULL DATA SET | | | | | | | | | |
| Bi-directional Energy Measurements | | | | | | • | • | • | • |
| Power (3-phase total and per phase): Real (kW) Reactive (kVAR), and Apparent (kVA) | • | • | • | • | • | • | • | • | • |
| Power Factor: 3-phase average & per phase | • | • | • | • | • | • | • | • | • |
| Present Power Demand: Real (kW), Reactive (kVAR), and Apparent (kVA) | • | • | • | • | • | • | • | • | • |
| Import and Export totals of Present Power Demand: Real (kW), Reactive (kVAR), & Apparent (kVA) | | | | | | • | • | • | • |
| Peak Power Demand: Real (kW), Reactive (kVAR), and Apparent (kVA) | • | • | • | • | • | • | • | • | • |
| Current (3-phase average and per phase) | • | • | • | • | • | • | • | • | • |
| Voltage: Line-Line and Line-Neutral (3-phase average and per phase) | • | • | • | • | • | • | • | • | • |
| Frequency | • | • | • | • | • | • | • | • | • |
| ANSI C12.20 0.2% accuracy, IEC 62053-22 Class 0.2S | • | • | • | • | • | • | • | • | • |
| Accumulated Net Energy: Real (kWh), Reactive (kVARh), and Apparent (kVAh) | • | • | • | • | • | • | • | • | • |
| Accumulated Real Energy by phase (kWh) | • | • | • | • | • | • | • | • | • |
| Import and Export Accumulators of Real and Apparent Energy | | | | | | • | • | • | • |
| Reactive Energy Accumulators by Quadrant (3-phase total & per phase) | | | | | | • | • | • | • |
| Demand Interval Configuration: Fixed or Rolling Block | • | • | • | • | • | • | • | • | • |
| Demand Interval Configuration: External Sync to Comms | | • | • | • | • | • | • | • | • |
| DATA LOGGING | | | | | | | | | |
| Data Logging: 10 16-Bit Configurable (can include Date/Time) Data Buffers | | | • | | | | • | | |
| Data Logging: 3 Timestamped 32-Bit Configurable Data Buffers | | | | | • | | | | • |
| Store up to 60 days of readings at 15-minute intervals | | | • | | • | | • | | • |
| OUTPUTS | | | | | | | | | |
| Alarm Output (N.C.) | • | • | • | • | | • | • | • | • |
| 1 Pulse Output (N.O.) | | • | • | | | • | • | | |
| 2 Pulse Outputs (N.O.) | • | | | | | | | | |
| RS-485 Serial (Modbus RTU Protocol) | | • | • | | | • | • | | |
| RS-485 Serial (BACnet MS/TP Protocol) | | | | • | • | | | • | • |
| INPUTS | | | | | | | | | |
| 2 Pulse Contact Accumulator Inputs | | | | | • | | | | • |
| 1 Pulse Contact Accumulator Input | | | | • | | | | • | |

DIMENSIONAL DRAWING

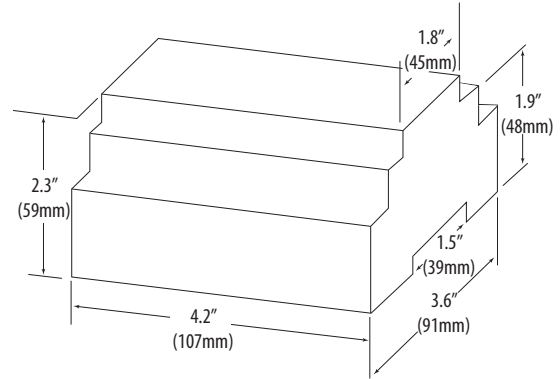

DIN MOUNT CONFIGURATION

Mounting Diagram

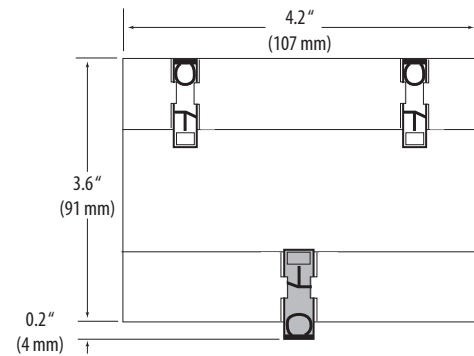

SCREW MOUNT CONFIGURATION

Mounting Diagram

