

## Features

- 2-Way Normally Closed Operation.
- Unique double disc design with overtravel provides redundant sealing for leak tight shutoff.
- Die-cast aluminum bodies.
- Zero differential piloted diaphragm.
- For on-off control of fuel gas in commercial and industrial gas burners.
- Valves provided with 1/8" NPT upstream and downstream pipe tap with plug for routine testing.

## Construction

Valve Parts in Contact with Fluids	
Body	Aluminum
Seals and Disc	NBR
Core Tube	305 Stainless Steel
Core Guide	Acetal (20.1 watt only)
Rider Ring	PTFE (20.1 watt only)
Core and Plugnut	430F Stainless Steel
Springs	302 Stainless Steel
Shading Coil	Copper
Pipe Plug	Zinc-Plated Steel

## Electrical

Standard Coil Class of Insulation	Watt Rating and Power Consumption				*Ambient Temp. °F	Spare Coil Family			
	DC Watts	AC				General Purpose		Explosionproof	
		Watts	VA Holding	VA Inrush		AC	DC	AC	DC
F	-	17.1	40	93	-40 to 125	238610	-	-	-
F	-	20.1	48	240	-40 to 125	272610	-	-	-
F	22.6	-	-	-	-20 to 104	-	238710	-	-

**Standard Voltages:** 24, 120, 240 volts AC, 60 Hz (or 110, 220 volts AC, 50 Hz) (238610); 120, 240 volts AC, 60 Hz (272610); 12, 24 volts DC.  
 \*Agency approval pending to extend low ambient temperature rating from -20°F to -40°F for DC constructions.

## Solenoid Enclosures

RedHat® II molded epoxy Type 1, 2, 3, 3S, 4 and 4X combination. General Purpose and Watertight solenoid enclosures with 1/2" conduit hub as standard.

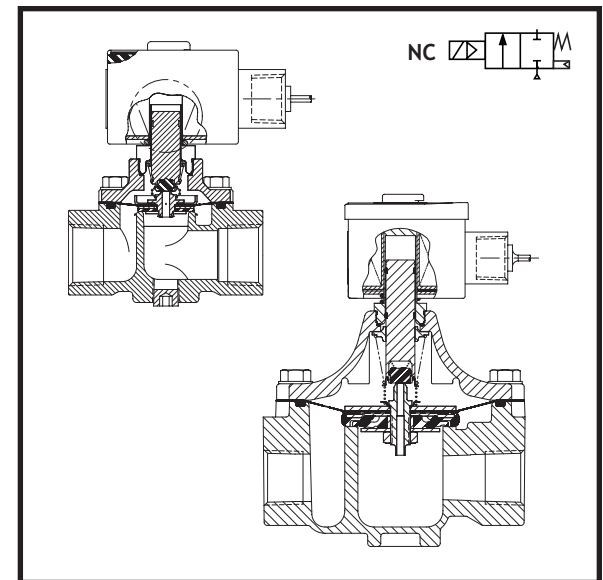

## Approvals:

UL listed to standard 429 "Electrically Operated Valves," Guide YIOZ, File MP618 Safety Shutoff Valves.

FM Approved to Class 7400 "liquid and gas safety shutoff valves."

CSA Certified to:

- 1) Standard C22.2 No. 139 "Electrically Operated Valves," File 010381.
- 2) Automatic Gas Valves Z21.21 (6.5), File 112872.
- 3) Automatic Gas Safety Shutoff Valves C/I (3.9), File 112872.

Specifications

Pipe Size (ins.)	Orifice Size (ins.)	CV Flow	Gas Capacity ①	Operating Pressure Differential (psi)		Max. Fluid Temp. °F		Catalog Number	Const. Ref.	Agency			Wattage		Approx. Shipping Weight (lbs)
				Btu/hr.	Min.	Max.	AC			DC	UL	FM	CSA	AC	
<b>COMBUSTION (Fuel Gas) - NORMALLY CLOSED</b>															
3/8	3/4	3.4	183,000	0	5	125	104	8214G010	1	○	○	○	17.1	22.6	2
1/2	3/4	4.4	238,500	0	5	125	104	8214G020	1	○	○	○	17.1	22.6	2
3/4	3/4	5.1	247,500	0	5	125	104	8214G030	2	○	○	○	17.1	22.6	2
3/4	1 5/8	11	580,000	0	5	125	-	8214G036	3	○	○	○	20.1	-	4.3
1	1 5/8	21	1,119,000	0	5	125	-	8214G051	3	○	○	○	20.1	-	4.3
1 1/4	1 5/8	32	1,730,000	0	5	125	-	8214G061	4	○	○	○	20.1	-	4.3
1 1/2	1 5/8	35	1,900,000	0	5	125	-	8214G071	4	○	○	○	20.1	-	4.3
2	2 3/32	60	2,800,000	0	5	125	-	8214G081	5	○	○	○	20.1	-	6.3

○ = Safety Shutoff Valve. ① 1" W.C. Drop @ 2" W.C. Inlet Pressure, 1, 000 Btu/cu.ft. or more, 0.64 Specific Gravity Gas.

Capabilities Chart

Solenoid Options		Base Catalog Number	Resilient Materials	Standard Rebuild Kit	
High Temp.	Junction Box	Aluminum	NBR	AC	DC
HB	JB	8214G010	●	316233	316790
HB	JB	8214G020	●	316233	316790
HB	JB	8214G030	●	316233	316790
HB	JB	8214G036	●	322374	-
HB	JB	8214G051	●	322374	-
HB	JB	8214G061	●	322374	-
HB	JB	8214G071	●	322374	-
HB	JB	8214G081	●	322376	-

● = Standard. Other options may be available. All option combinations may not be available. Solenoid options are for AC only.

Dimensions: inches

Const. Ref.	A	B	E	H	J	K	L	N	P	R	T	W
1	1.14	3.03	1.36	4.08	2.04	2.47	2.75	3.42	3.46	1.38	1.95	2.50
2	1.14	3.03	1.25	4.52	2.04	2.66	3.31	3.70	3.64	1.66	1.95	2.39
3	2.69	3.11	2.69	6.73	2.05	4.20	5.00	4.67	5.41	2.62	2.06	5.39
4	2.69	3.11	2.69	6.73	2.05	4.27	5.00	4.67	5.48	2.62	2.06	5.39
5	3.16	3.11	3.16	7.34	2.05	4.63	6.09	5.33	5.48	3.28	2.06	6.32

**Const. Ref. 1, 2**

**Const. Ref. 3, 4, 5**

Must be mounted with solenoid vertical and upright with 20.1 watt coil.