

## General Description

The H137 is a 2-way, normally closed, safety shutoff valve providing trouble free, electrohydraulic on-off control of combustion gas for boilers, industrial furnaces, dryers, dehydrators, large conversion burners, air heaters and similar applications.

The self-contained Hydramotor® actuator is a powerful, pull-type hydraulic ram providing output force of 1,400 pounds to fully open the valve. Upon current interruption, dual redundant relief valves dump hydraulic pressure, closing the valve in one second. The Hydramotor® consists of a motor/pump unit immersed in oil, reducing wear and provides highly reliable operation.

The H137 is a cast iron-bodied valve with Nitrile seat and aluminum trim. Pulling force from the Hydramotor® actuator moves a lever (providing mechanical advantage) against spring and gas pressure to open the soft-seated flap, allowing straight-through gas flow.

A simple, two-wire circuit controls the motorized valve. Each H137 is equipped with one standard SPDT switch which actuates at the fully-open (energized) position. Each is equipped with a valve seal overtravel interlock switch which can be wired into the startup or pre-ignition interlock circuit to permit supervision of the valve's closed position (FM proof of closure).

## Specifications

Fluid: Fuel gas

Opening Time: 27 seconds max.

Closing Time: 1 second max.

Enclosure: Type 4 Watertight standard.

Type 7 Explosionproof optional.

Ambient Temperature: -40°F to 150°F (-40°C to 66°C)

Body Class: Cast Iron, 2" to 3": 250# screw, 4"-6": 125# flanges.

Pipe Taps: 1/4" upstream & downstream taps for routine leak testing.

## Electrical

Power Requirement: 324 VA

Standard Voltage: 110-120V/50-60Hz

Operating Voltage	Amperes		
	Inrush	Opening	Holding
110-120V/50-60Hz	270	2.7	0.18

**Auxiliary Switch:** Integral SPDT switch, 15A@120V Actuates at full open position of actuator stroke (not adjustable). Up to 2 adjustable yoke mounted switches may be added.

**Proof of Closure Switch:** Integral factory set, non-field adjustable SPDT switch, 1/4 HP@120V.



## Installation

Multi-poise, may be mounted in any position.

## Approvals:

UL listed

FM Approved

CSA Certified to:

1) Automatic Gas Safety Shutoff Valves C/I (3.9), File 113070.

Specifications

Catalog Number	Pipe Connection (NPT)	Gas Capacity ft <sup>3</sup> /hr *		Cv Flow	Max. Operating Pressure Differential (psi)	Const. Ref.	Opening Time	Shipping Weight lbs.
		P 1" W.C.	P 5 psi					
H137CJ12F1F26V16	2	8,000	210,000	151	60	1	22	130
H137CK12F1F26V16	2 1/2	12,900	250,000	244	50	2	22	135
H137CL12F1F26V16	3	17,000	360,000	320	50	2	22	135
H137CN32F1F26V16	4 (Flange)	27,000	600,000	510	30	3	27	143
H137CQ32F1F26V16	6 (Flange)	50,000	1,200,000	1020	20	4	27	150

\*One cubic foot per hour = 1,000 Btu/hr, 0.64 specific gravity natural gas @ 1" W.C.P.D.

Dimensions: inches

Const. Ref.	A	B	C	D
1	8.12	25.25	2.50	4.95
2	11.00	26.09	2.88	6.50
3	13.87	28.69	4.06	7.75
4	17.81	29.75	5.13	10.35

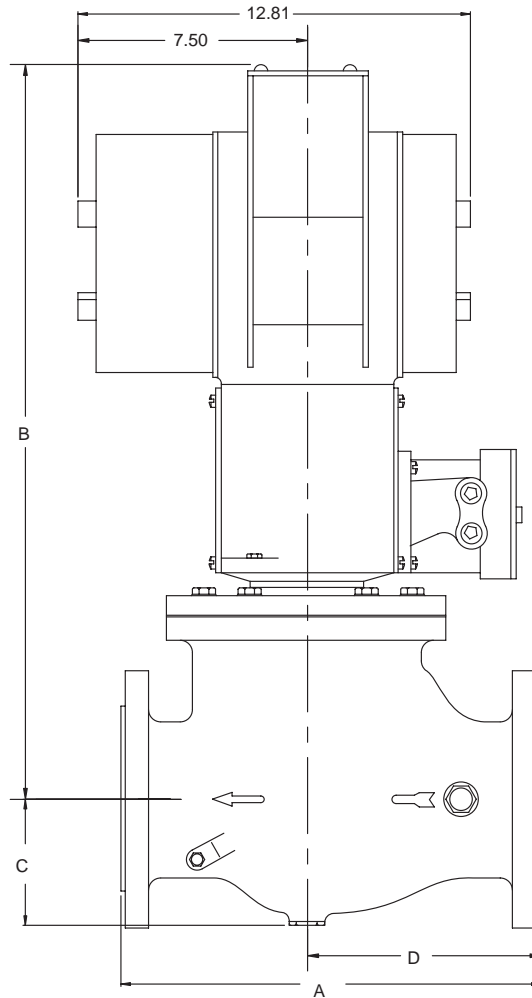

Replacement Actuators:

Catalog Number	Voltage
H30A4820B20C1F1F26	110-120V/50-60Hz

Replacement Switches:

Kits	Switches*	Type
S104772FAX1	1	Proof of Closure
S104772FAX2	2	1 Proof of Closure and 1 Auxiliary
S104772FAX3	3	1 Proof of Closure and 2 Auxiliary

\*Yoke Mounted