

Features

- Handle the challenges of high-temperature fluids.
- PTFE and EPDM discs, stainless steel seats, plus high-temperature coils, help provide long, reliable service life.
- Wide range of valve constructions, including Straight Through and Slow Closing, with Normally Closed and Normally Open operation.
- Specify these valves for the high-temperature applications found in laundries, molding, steam atomization, sterilizers, autoclaves, and many others.
 - Series 8263: direct acting miniature valves.
 - Series 8267: direct acting straight through, self-cleaning design.
 - Series 8210/8220: pilot operated diaphragm valves.
 - Series 8220: heavy-duty, pilot operated piston valves have stainless steel pistons.
 - Series 8221: slow-closing, anti-water hammer design.
 - Series 8222: pilot operated diaphragm and piston valves. Y-body floating piston design.

Construction

Valve Parts in Contact with Fluids		
Common Parts		
Body	Brass	Stainless Steel
Core Tube	305 Stainless Steel	
Core and Plugnut	430F Stainless Steel	
Springs	302 Stainless Steel	
Shading Coil	Copper	Silver
8210HW Series		
Seals, Discs, and Diaphragms	EPDM	
8263 Series		
Seals	PTFE	
Disc	EPDM or PTFE	
8220/8221 Series		
Piston	Stainless Steel	
Discs	EPDM or PTFE	
Seals	EPDM, PTFE	
8222 Series		
Seals, Discs, and Diaphragms	EPDM and/or PTFE	
Piston	Brass or PTFE	
8267 Series		
Seals	FKM, PTFE	
Disc	Stainless Steel	
Seat	Glass-Filled PTFE	

Electrical

See individual valve series in General Service Section for details.

Solenoid Enclosures

Standard: Red-Hat II - Watertight, Types 1, 2, 3, 3S, 4, and 4X; Red-Hat - Type 1.
Optional: Red-Hat II - Explosionproof and Watertight, Types 3, 3S, 4, 4X, 6, 6P, 7, and 9; Red-Hat - Explosionproof and Raintight, Types 3, 7, and 9. (To order, add prefix "EF" to catalog number.)
 See Optional Features Section for other available options.

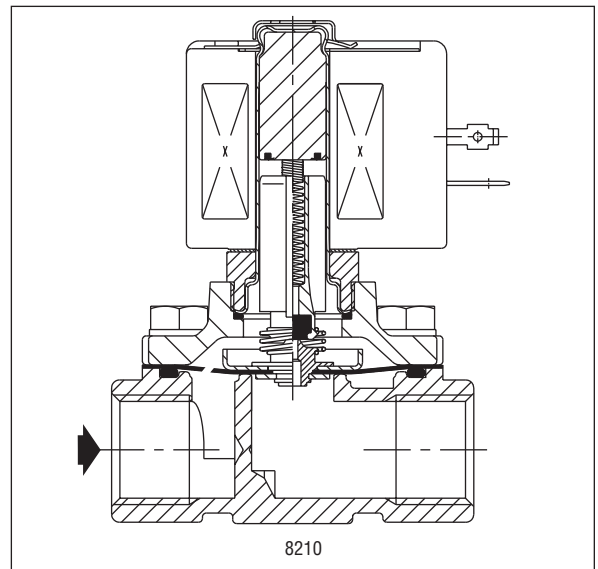
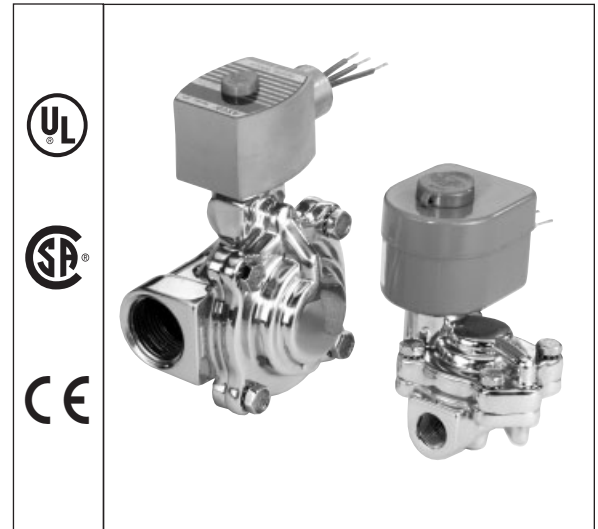

Nominal Ambient Temperature Ranges:

Red-Hat II/
 Red-Hat AC: 32°F to 125°F (0°C to 52°C)
 Red-Hat II DC: 32°F to 104°F (0°C to 40°C)
 Red-Hat DC: 32°F to 77°F (0°C to 25°C)
 (104°F/40°C occasionally)

Refer to Engineering Section for details.

Approvals:

Most are UL listed, CSA certified, and meet applicable CE directives. Contact ASCO for details.

Important: Explosionproof Catalog Numbers EF8210HW, EF8220, EF8221, and EF8263 are not UL listed. They are suitable for Types 4, 7 (C and D), and 9 (E and F) only, and have a temperature range code of T3A.

Specifications (English units)

Pipe Size (ins.)	Orifice Size (ins.)	Cv Flow Factor	Operating Pressure Differential (psi)			Max. Fluid Temp. °F		Brass Body		AC Watt Rating/ Class of Coil Insulation	
			Hot Water			Hot Water		Catalog Number	Constr. Ref. No.	AC	DC
			Min. ④	Max. AC	Max. DC	AC	DC				
HOT WATER SERVICE ONLY - NORMALLY CLOSED (Closed when de-energized), EPDM Diaphragm											
3/8	5/8	3	0 ③	100	40	210	150	8210G93HW	32	10.1/F	11.6/F
3/8	5/8	3	5	125	100	210	150	8210G1HW	33	6.1/F	11.6/F
1/2	5/8	4	0 ③	100	40	210	150	8210G94HW	32	10.1/F	11.6/F
1/2	5/8	4	5	125	100	210	150	8210G2HW	33	6.1/F	11.6/F
3/4	3/4	5	0 ③	100	40	210	150	8210G95HW	34	10.1/F	11.6/F
3/4	3/4	5	5	125	100	210	150	8210G9HW	35	6.1/F	11.6/F
SLOW CLOSING - NORMALLY CLOSED (Closed when de-energized), EPDM Disc											
3/8	9/16	3	5 ②	150	-	210	-	8221G1HW	36	6.1/F	-
1/2	9/16	3.5	5 ②	150	-	210	-	8221G3HW	36	6.1/F	-
3/4	3/4	5.5	5 ②	150	-	210	-	8221G5HW	36	6.1/F	-
1	1	11.5	5 ②	150	-	210	-	8221G7HW	38	6.1/F	-
1 1/4	1 1/8	13	5 ②	150	-	210	-	8221G9HW	39	6.1/F	-
1 1/2	1 1/4	24	5 ②	150	-	210	-	8221G11HW	40	6.1/F	-
2	1 3/4	36	5 ②	150	-	210	-	8221G13HW	41	6.1/F	-
2 1/2	1 3/4	38	5 ②	150	-	210	-	8221G15HW	42	6.1/F	-
SLOW CLOSING - NORMALLY OPEN (Open when de-energized), EPDM Disc											
3/8	9/16	3	5 ②	150	-	210	-	8221G21HW	43	16.1/F	-
1/2	9/16	3.5	5 ②	150	-	210	-	8221G23HW	43	16.1/F	-
3/4	3/4	5.5	5 ②	150	-	210	-	8221G25HW	44	16.1/F	-
1	1	11.5	5 ②	150	-	210	-	8221G27HW	45	16.1/F	-
1 1/4	1 1/8	13	5 ②	150	-	210	-	8221G29HW	46	16.1/F	-
1 1/2	1 1/4	24	5 ②	150	-	210	-	8221G31HW	47	16.1/F	-
2	1 3/4	36	5 ②	150	-	210	-	8221G33HW	48	16.1/F	-
2 1/2	1 3/4	38	5 ②	150	-	210	-	8221G35HW	49	16.1/F	-

Pipe Size (ins.)	Orifice Size (ins.)	Cv Flow Factor	Operating Pressure Differential (psi)			Max. Fluid Temp. °F		Brass Body		Stainless Steel Body		AC Watt Rating/ Class of Coil Insulation
			Min. ④	Max.		Steam	Hot Water	Catalog Number	Constr. Ref. No.	Catalog Number	Constr. Ref. No.	
				Steam	Hot Water							
DIRECT ACTING - NORMALLY CLOSED (Closed when de-energized), Stainless Steel Seat, EPDM ⑤, or PTFE Disc												
1/8	1/8	.34	0	50	-	298	-	8263G52 ⑤	1	-	-	6.1/F
1/8	1/8	.34	0	90	-	331	-	8263G58	1	-	-	6.1/F
1/4	1/8	.34	0	50	-	298	-	8263G53 ⑤	2	-	-	6.1/F
1/4	1/8	.34	0	90	-	331	-	8263G59	2	-	-	6.1/F
1/4	5/32	.52	0	110	110	344	210	8263G300	3	-	-	10.1/H
1/4	7/32	.72	0	70	-	316	-	8263G301	3	-	-	10.1/H
1/4	9/32	.85	0	60	-	307	-	8263G303	3	-	-	17.1/H
3/8	1/8	.36	0	125	125	353	210	8263G304	3	8263G318	31	10.1/H
3/8	5/32	.52	0	110	110	344	210	8263G305	3	8263G319	31	10.1/H
3/8	7/32	.72	0	70	-	316	-	8263G306	3	8263G320	31	10.1/H
3/8	9/32	.85	0	60	-	307	-	8263G308	3	8263G321	31	17.1/H
PILOT OPERATED - NORMALLY CLOSED (Closed when de-energized)												
1/4	3/8	1.2	1	80	-	324	-	8222G68	4	-	-	6.1/F
1/4	3/8	1.2	1	125	-	353	-	8222G70	4	-	-	6.1/H
3/8	3/8	2.5	1	80	-	324	-	8222G64	4	-	-	6.1/F
3/8	3/8	2.5	1	125	-	353	-	8222G74	4	-	-	6.1/H
3/8	5/8	3.0	5 ①	50	150	300	210	8220G1	5	-	-	10.1/F
3/8	5/8	3.0	5 ①	125	150	353	210	8220G19	5	-	-	10.1/H
3/8	5/8	3.0	0	125	-	353	-	8222G1	6	-	-	17.1/H
3/8	5/8	3.0	0	50	-	300	-	8222G93	7	-	-	10.1/F
1/2	3/8	2.5	1	80	-	324	-	8222G66	4	-	-	6.1/F
1/2	3/8	2.5	1	125	-	353	-	8222G76	4	-	-	6.1/H
1/2	1/2	3.6	2	125	-	353	-	8222G47	9	-	-	10.1/H
1/2	5/8	4.0	0	50	-	300	-	8222G94	7	8222G60	28	10.1/F
1/2	5/8	4.0	0	125	-	353	-	8222G2	6	8222G87	29	17.1/H
1/2	5/8	4.0	5 ①	50	150	300	210	8220G3	5	-	-	10.1/F
1/2	5/8	4.0	5 ①	125	150	353	210	8220G21	5	-	-	10.1/H

Specifications (English units continued)

Pipe Size (ins.)	Orifice Size (ins.)	Cv Flow Factor	Operating Pressure Differential (psi)			Max. Fluid Temp. °F		Brass Body		Stainless Steel Body		AC Watt Rating/ Class of Coil Insulation
			Min. ④	Steam	Hot Water	Steam	Hot Water	Catalog Number	Constr. Ref. No.	Catalog Number	Constr. Ref. No.	
PILOT OPERATED - NORMALLY CLOSED (Closed when de-energized)												
3/4	5/8	4.5	0	50	-	300	-	-	-	8222G62	28	10.1/F
3/4	5/8	4.5	0	125	-	353	-	-	-	8222G88	29	17.1/H
3/4	3/4	5.0	0	50	-	300	-	8222G95	10	-	-	10.1/F
3/4	3/4	5.0	5 ①	50	150	300	210	8220G5	8	-	-	10.1/F
3/4	3/4	5.0	5 ①	125	150	353	210	8220G23	8	-	-	10.1/H
3/4	3/4	5.0	0	125	-	353	-	8222G3	11	-	-	17.1/H
3/4	1/2	4.6	2	125	-	353	-	8222G49	9	-	-	10.1/H
3/4	1/2	4.6	5	200	-	388	-	8222G5	12	-	-	10.1/H
1	1	11.2	5	125	-	353	-	-	-	8222G89	30	10.1/F
1	1	13.5	5 ②	50	150	300	210	8220G7	14	-	-	10.1/F
1	1	13.5	5 ②	125	150	353	210	8220G25	14	-	-	10.1/H
1	1	13.5	5	125	-	353	-	8222G4	13	-	-	10.1/H
1	1	13.0	0	200	-	388	-	822299	13	-	-	28.2/H
1 1/4	1 1/8	15	5 ②	50	150	300	210	8220G9	15	-	-	10.1/F
1 1/4	1 1/8	15	5 ②	125	150	353	210	8220G27	15	-	-	10.1/H
1 1/2	1 1/4	22.5	5 ②	50	150	300	210	8220G11	16	-	-	10.1/F
1 1/2	1 1/4	22.5	5 ②	125	150	353	210	8220G29	16	-	-	10.1/H
2	1 3/4	43	5 ②	50	150	300	210	8220G13	17	-	-	10.1/F
2	1 3/4	43	5 ②	125	150	353	210	8220G31	17	-	-	10.1/H
2 1/2	1 3/4	45	5 ②	50	150	300	210	8220G15	18	-	-	10.1/F
2 1/2	1 3/4	45	5 ②	125	150	353	210	8220G33	18	-	-	10.1/H
DIRECT ACTING, STRAIGHT-THROUGH DESIGN - NORMALLY CLOSED (Closed when de-energized)												
3/8	1/4	1.5	0	75	-	320	-	8267G1	19	-	-	16.1/H
3/8	3/8	5.1	0	30	-	280	-	8267G3	19	-	-	16.1/H
1/2	1/4	1.4	0	75	-	320	-	8267G5	19	-	-	16.1/H
1/2	3/8	4.5	0	15	-	250	-	8267G7	19	-	-	16.1/H
3/4	3/8	5.4	0	30	-	280	-	8267G17	20	-	-	16.1/H
3/4	1/2	9.7	0	15	-	250	-	8267G19	20	-	-	16.1/H
DIRECT ACTING, STRAIGHT-THROUGH DESIGN - NORMALLY OPEN (Open when de-energized)												
3/8	1/4	1.5	0	75	-	320	-	8267G9	19	-	-	16.1/H
3/8	3/8	5.1	0	30	-	280	-	8267G11	19	-	-	16.1/H
1/2	1/4	1.4	0	75	-	320	-	8267G13	19	-	-	16.1/H
1/2	3/8	4.5	0	15	-	250	-	8267G15	19	-	-	16.1/H
3/4	3/8	5.4	0	25	-	267	-	8267G21	20	-	-	16.1/H
3/4	1/2	9.7	0	15	-	250	-	8267G23	20	-	-	16.1/H
PILOT OPERATED - NORMALLY OPEN (Open when de-energized)												
3/8	9/16	3	5	50	150	300	210	8220G71	21	-	-	16.1/F
3/8	9/16	3	5	125	150	353	210	8220G91	21	-	-	16.1/F
1/2	9/16	4	5	50	150	300	210	8220G73	21	-	-	16.1/F
1/2	9/16	4	5	125	150	353	210	8220G93	21	-	-	16.1/F
3/4	3/4	5	5	50	150	300	210	8220G75	22	-	-	16.1/F
3/4	3/4	5	5	125	150	353	210	8220G95	22	-	-	16.1/F
1	1	13.5	5	50	150	300	210	8220G77	23	-	-	16.1/F
1	1	13.5	5	125	150	353	210	8220G97	23	-	-	16.1/H
1 1/4	1 1/8	15	5	50	150	300	210	8220G79	24	-	-	16.1/F
1 1/4	1 1/8	15	5	125	150	353	210	8220G99	24	-	-	16.1/H
1 1/2	1 1/4	22.5	5	50	150	300	210	8220G81	25	-	-	16.1/F
1 1/2	1 1/4	22.5	5	125	150	353	210	8220G101	25	-	-	16.1/H
2	1 3/4	43	5	50	150	300	210	8220G83	26	-	-	16.1/F
2	1 3/4	43	5	125	150	353	210	8220G103	26	-	-	16.1/H
2 1/2	1 3/4	45	5	50	150	300	210	8220G85	27	-	-	16.1/F
2 1/2	1 3/4	45	5	125	150	353	210	8220G105	27	-	-	16.1/F
Notes: ① Once opened at higher pressure, valve will remain open to 0 psi at inlet. ② Once opened at higher pressure, valve will remain open to 3 psi at inlet. ③ 0 psi on AC construction, 1/4 psi on DC construction. ④ Series 8220 Normally Closed valves through 3/4" will remain open to 0 psi while energized. Once opened at 5 psi, larger sizes will remain open to 3 psi, as will all Series 8220 Normally Open valves. ⑤ EPDM disc.												

Specifications (Metric units)

Pipe Size (ins.)	Orifice Size (mm)	Kv Flow Factor (m3/h)	Operating Pressure Differential (bar)			Max. Fluid Temp. °C				Watt Rating/ Class of Coil Insulation	
			Hot Water			Hot Water		Brass Body		AC	DC
			Min. ④	Max. AC	Max. DC	AC	DC	Catalog Number	Constr. Ref. No.		
HOT WATER SERVICE ONLY - NORMALLY CLOSED (Closed when de-energized), EPDM Diaphragm											
3/8	16	2.57	0 ③	6.9	2.8	98	65	8210G93HW	32	10.1/F	11.6/F
3/8	16	2.57	0.3	8.6	6.9	98	65	8210G1HW	33	6.1/F	11.6/F
1/2	16	3.43	0 ③	6.9	2.8	98	65	8210G94HW	32	10.1/F	11.6/F
1/2	16	3.43	0.3	8.6	6.9	98	65	8210G2HW	33	6.1/F	11.6/F
3/4	19	4.29	0 ③	6.9	2.8	98	65	8210G95HW	34	10.1/F	11.6/F
3/4	19	4.29	0.03	8.6	6.9	98	65	8210G9HW	35	6.1/F	11.6/F
SLOW CLOSING - NORMALLY CLOSED (Closed when de-energized), EPDM Disc											
3/8	14	2.57	0.3 ②	10.3	-	98	-	8221G1HW	36	6.1/F	-
1/2	14	3.00	0.3 ②	10.3	-	98	-	8221G3HW	36	6.1/F	-
1	25	9.86	0.3 ②	10.3	-	98	-	8221G7HW	38	6.1/F	-
1 1/4	29	11.14	0.3 ②	10.3	-	98	-	8221G9HW	39	6.1/F	-
1 1/2	32	20.57	0.3 ②	10.3	-	98	-	8221G11HW	40	6.1/F	-
2	44	30.86	0.3 ②	10.3	-	98	-	8221G13HW	41	6.1/F	-
2 1/2	44	32.57	0.3 ②	10.3	-	98	-	8221G15HW	42	6.1/F	-
SLOW CLOSING - NORMALLY OPEN (Open when de-energized), EPDM Disc											
3/8	14	2.57	0.3 ②	10.3	-	98	-	8221G21HW	43	16.1/F	-
1/2	14	3.00	0.3 ②	10.3	-	98	-	8221G23HW	43	16.1/F	-
3/4	19	4.71	0.3 ②	10.3	-	98	-	8221G25HW	44	16.1/F	-
1	25	9.86	0.3 ②	10.3	-	98	-	8221G27HW	45	16.1/F	-
1 1/4	29	11.14	0.3 ②	10.3	-	98	-	8221G29HW	46	16.1/F	-
1 1/2	32	20.57	0.3 ②	10.3	-	98	-	8221G31HW	47	16.1/F	-
2	44	30.86	0.3 ②	10.3	-	98	-	8221G33HW	48	16.1/F	-
2 1/2	44	32.57	0.3 ②	10.3	-	98	-	8221G35HW	49	16.1/F	-

Pipe Size (ins.)	Orifice Size (mm)	Kv Flow Factor (m3/h)	Operating Pressure Differential (bar)			Max. Fluid Temp. °C		Brass Body		Stainless Steel Body		AC Watt Rating/ Class of Coil Insulation
			Min. ④	Max.		Steam	Hot Water	Catalog Number	Constr. Ref. No.	Catalog Number	Constr. Ref. No.	
				Steam	Hot Water							
DIRECT ACTING - NORMALLY CLOSED (Closed when de-energized), Stainless Steel Seat EPDM ⑤, or PTFE Disc												
1/8	3	.29	0	3	-	146	-	8263G52 ⑤	1	-	-	6.1/F
1/8	3	.29	0	6	-	164	-	8263G58	1	-	-	6.1/F
1/4	3	.29	0	3	-	146	-	8263G53 ⑤	2	-	-	6.1/F
1/4	3	.29	0	6	-	164	-	8263G59	2	-	-	6.1/F
1/4	4	.45	0	8	8	172	98	8263G300	3	-	-	10.1/H
1/4	6	.62	0	5	-	156	-	8263G301	3	-	-	10.1/H
1/4	7	.73	0	4	-	151	-	8263G303	3	-	-	17.1/H
3/8	3	.31	0	9	9	177	98	8263G304	3	8263G318	31	10.1/H
3/8	4	.45	0	8	8	172	98	8263G305	3	8263G319	31	10.1/H
3/8	6	.62	0	5	-	156	-	8263G306	3	8263G320	31	10.1/H
3/8	7	.73	0	4	-	151	-	8263G308	3	8263G321	31	17.1/H
PILOT OPERATED - NORMALLY CLOSED (Closed when de-energized)												
1/4	10	1.03	0.07	6	-	161	-	8222G68	4	-	-	6.1/F
1/4	10	1.03	0.07	9	-	177	-	8222G70	4	-	-	6.1/H
3/8	10	2.14	0.07	6	-	161	-	8222G64	4	-	-	6.1/F
3/8	10	2.14	0.07	9	-	177	-	8222G74	4	-	-	6.1/H
3/8	16	2.57	.3 ①	3	10	147	98	8220G1	5	-	-	10.1/F
3/8	16	2.57	.3 ①	9	10	177	98	8220G19	5	-	-	10.1/H
3/8	16	2.57	0	9	-	177	-	8222G1	6	-	-	17.1/H
3/8	16	2.57	0	3	-	147	-	8222G93	7	-	-	10.1/F
1/2	10	2.14	0.07	6	-	161	-	8222G66	4	-	-	6.1/F
1/2	10	2.14	0.07	9	-	177	-	8222G76	4	-	-	6.1/H
1/2	13	3.09	0.1379	9	-	177	-	8222G47	9	-	-	10.1/H
1/2	16	3.43	0	3	-	147	-	8222G94	7	8222G60	28	10.1/F
1/2	16	3.43	0	9	-	177	-	8222G2	6	8222G87	29	17.1/H
1/2	16	3.43	.3 ①	3	10	147	98	8220G3	5	-	-	10.1/F
1/2	16	3.43	.3 ①	9	10	177	98	8220G21	5	-	-	10.1/H

Specifications (Metric units continued)

Pipe Size (ins.)	Orifice Size (mm)	Kv Flow Factor (m ³ /h)	Operating Pressure Differential (bar)			Max. Fluid Temp. °C		Brass Body		Stainless Steel Body		AC Watt Rating/Class of Coil Insulation
			Min. ④	Max.		Steam	Hot Water	Catalog Number	Constr. Ref. No.	Catalog Number	Constr. Ref. No.	
				Steam	Hot Water							
PILOT OPERATED - NORMALLY CLOSED (Closed when de-energized)												
3/4	16	3.86	0	3	-	147	-	-	-	8222G62	28	10.1/F
3/4	16	3.86	0	9	-	177	-	-	-	8222G88	29	17.1/H
3/4	19	4.29	0	3	-	147	-	8222G95	10	-	-	10.1/F
3/4	19	4.29	.3 ①	3	10	147	98	8220G5	8	-	-	10.1/F
3/4	19	4.29	.3 ①	9	10	177	98	8220G23	8	-	-	10.1/H
3/4	19	4.29	0	9	-	177	-	8222G3	11	-	-	17.1/H
3/4	13	3.94	0.14	9	-	177	-	8222G49	9	-	-	10.1/H
3/4	13	3.94	0.3	14	-	196	-	8222G5	12	-	-	10.1/H
1	25	9.60	0.3	9	-	177	-	-	-	8222G89	30	10.1/F
1	25	11.57	.3 ②	3	10	147	98	8220G7	14	-	-	10.1/F
1	25	11.57	.3 ②	9	10	177	98	8220G25	14	-	-	10.1/H
1	25	11.57	0.3	9	-	177	-	8222G4	13	-	-	10.1/H
1	25	11.14	0	14	-	196	-	822299	13	-	-	28.2/H
1 1/4	29	12.86	.3 ②	3	10	147	98	8220G9	15	-	-	10.1/F
1 1/4	29	12.86	.3 ②	9	10	177	98	8220G27	15	-	-	10.1/H
1 1/2	32	19.29	.3 ②	3	10	147	98	8220G11	16	-	-	10.1/F
1 1/2	32	19.29	.3 ②	9	10	177	98	8220G29	16	-	-	10.1/H
2	44	36.86	.3 ②	3	10	147	98	8220G13	17	-	-	10.1/F
2	44	36.86	.3 ②	9	10	177	98	8220G31	17	-	-	10.1/H
2 1/2	44	38.57	.3 ②	3	10	147	98	8220G15	18	-	-	10.1/F
2 1/2	44	38.57	.3 ②	9	10	177	98	8220G33	18	-	-	10.1/H
DIRECT ACTING, STRAIGHT-THROUGH DESIGN - NORMALLY CLOSED (Closed when de-energized)												
3/8	6	1.29	0	5	-	158	-	8267G1	19	-	-	16.1/H
3/8	10	4.37	0	2	-	136	-	8267G3	19	-	-	16.1/H
1/2	6	1.20	0	5	-	158	-	8267G5	19	-	-	16.1/H
1/2	10	3.86	0	1	-	120	-	8267G7	19	-	-	16.1/H
3/4	10	4.63	0	2	-	136	-	8267G17	20	-	-	16.1/H
3/4	13	8.31	0	1	-	120	-	8267G19	20	-	-	16.1/H
DIRECT ACTING, STRAIGHT-THROUGH DESIGN - NORMALLY OPEN (Open when de-energized)												
3/8	6	1.29	0	5	-	158	-	8267G9	19	-	-	16.1/H
3/8	10	4.37	0	2	-	136	-	8267G11	19	-	-	16.1/H
1/2	6	1.20	0	5	-	158	-	8267G13	19	-	-	16.1/H
1/2	10	3.86	0	1	-	120	-	8267G15	19	-	-	16.1/H
3/4	10	4.63	0	2	-	129	-	8267G21	20	-	-	16.1/H
3/4	13	8.31	0	1	-	120	-	8267G23	20	-	-	16.1/H
PILOT OPERATED - NORMALLY OPEN (Open when de-energized)												
3/8	14	2.57	0.3	3	10	147	98	8220G71	21	-	-	16.1/F
3/8	14	2.57	0.3	9	10	177	98	8220G91	21	-	-	16.1/F
1/2	14	3.43	0.3	3	10	147	98	8220G73	21	-	-	16.1/F
1/2	14	3.43	0.3	9	10	177	98	8220G93	21	-	-	16.1/F
3/4	19	4.29	0.3	3	10	147	98	8220G75	22	-	-	16.1/F
3/4	19	4.29	0.3	9	10	177	98	8220G95	22	-	-	16.1/F
1	25	11.57	0.3	3	10	147	98	8220G77	23	-	-	16.1/F
1	25	11.57	0.3	9	10	177	98	8220G97	23	-	-	16.1/H
1 1/4	29	12.86	0.3	3	10	147	98	8220G79	24	-	-	16.1/F
1 1/4	29	12.86	0.3	9	10	177	98	8220G99	24	-	-	16.1/H
1 1/2	32	19.29	0.3	3	10	147	98	8220G81	25	-	-	16.1/F
1 1/2	32	19.29	0.3	9	10	177	98	8220G101	25	-	-	16.1/H
2	44	36.86	0.3	3	10	147	98	8220G83	26	-	-	16.1/F
2	44	36.86	0.3	9	10	177	98	8220G103	26	-	-	16.1/H
2 1/2	44	38.57	0.3	3	10	147	98	8220G85	27	-	-	16.1/F
2 1/2	44	38.57	0.3	9	10	177	98	8220G105	27	-	-	16.1/F

Notes: ① Once opened at higher pressure, valve will remain open to 0 bar at inlet.
 ② Once opened at higher pressure, valve will remain open to 0.2 bar at inlet.
 ③ 0 psi on AC construction, 0.02 bar on DC construction.
 ④ Series 8220 Normally Closed valves through 3/4" will remain open to 0 bar while energized. Once opened at 0.3 bar, larger sizes will remain open to 0.2 bar, as will all Series 8220 Normally Open valves.
 ⑤ EPDM disc.

Dimensions: inches (mm)

Const. Ref. No.		H	K	L	P	W
1	ins.	2.52	1.30	Ø 1.19	2.16	1.69
	mm	64	33	Ø 30	55	43
2	ins.	3.01	1.73	Ø 1.25	2.59	1.69
	mm	76	44	Ø 32	66	43
3	ins.	3.25	1.70	1.88	2.67	1.95
	mm	83	43	48	68	50
4	ins.	4.17	3.25	2.28	3.63	1.69
	mm	106	83	58	92	43
5	ins.	4.05	2.52	2.75	3.48	2.28
	mm	103	64	70	88	58
7	ins.	3.84	2.31	2.75	3.28	2.29
	mm	98	59	70	83	58
8	ins.	4.34	2.68	2.81	3.65	2.28
	mm	110	68	71	93	58
9	ins.	4.81	3.62	2.75	4.01	1.95
	mm	122	92	70	102	50
10	ins.	4.14	2.47	2.81	3.44	2.29
	mm	105	63	71	87	58
12	ins.	4.81	3.63	2.75	4.01	1.95
	mm	122	92	70	102	50
32	ins.	3.84	2.31	2.75	3.28	2.29
	mm	98	59	70	83	58
33	ins.	3.36	1.94	2.75	2.80	2.28
	mm	85	49	70	71	58
34	ins.	4.13	2.47	2.81	3.44	2.29
	mm	105	63	71	87	58
35	ins.	3.66	2.10	2.81	2.96	2.28
	mm	93	53	71	75	58

Constr. Ref. 1, 2

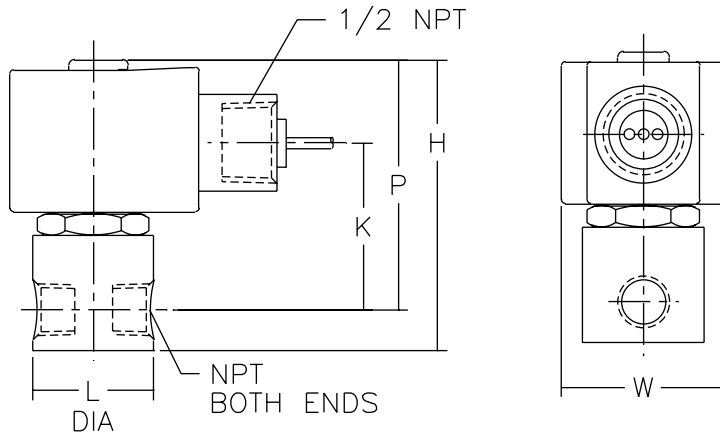

Constr. Ref. 3

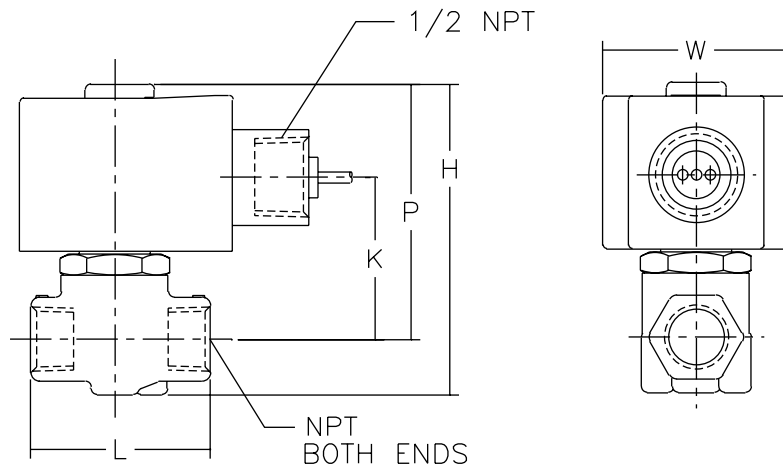

Constr. Ref. 4, 9, 12

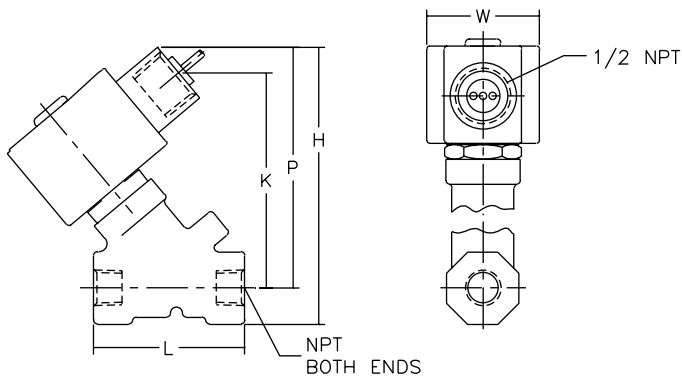

Constr. Ref. 5, 7, 8, 10, 32-35

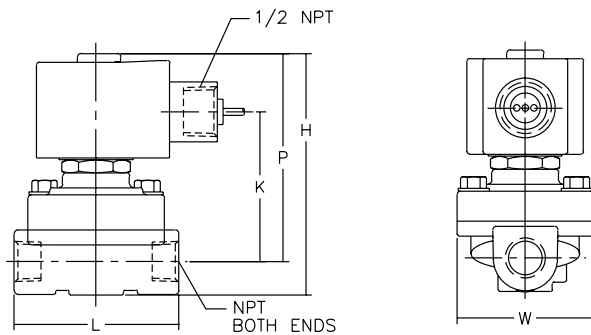

Dimensions: inches (mm)

Const. Ref. No.		H	K	L	P	W
6	ins.	4.68	3.15	2.75	4.12	2.28
	mm	119	80	70	105	58
11	ins.	4.97	3.45	2.81	4.28	2.28
	mm	126	88	71	109	58
13	ins.	5.82	3.22	3.75	4.19	3.31
	mm	148	82	95	106	84
14	ins.	5.81	3.22	3.75	4.19	3.14
	mm	148	82	95	106	80
15	ins.	5.81	3.22	3.66	4.19	3.56
	mm	148	82	93	106	90
16	ins.	6.29	3.37	4.38	4.34	4.10
	mm	160	86	111	110	104
17	ins.	7.51	3.78	5.06	4.75	4.71
	mm	191	96	129	121	120
18	ins.	7.51	3.78	5.50	4.75	5.18
	mm	191	96	140	121	132
23	ins.	6.46	3.36	3.75	4.86	3.14
	mm	164	85	95	123	80
24	ins.	6.39	3.36	3.66	4.86	3.56
	mm	162	85	93	123	90
25	ins.	6.97	3.51	4.38	5.01	4.10
	mm	177	89	111	127	104
26	ins.	8.18	3.92	5.06	5.42	4.71
	mm	208	100	129	138	120
27	ins.	8.18	3.92	5.50	5.42	5.18
	mm	208	100	140	138	132
29	ins.	5.04	3.34	2.81	4.31	2.28
	mm	128	85	71	109	58
38	ins.	5.64	3.15	3.75	4.01	3.14
	mm	143	80	95	102	80
39	ins.	5.64	3.15	3.66	4.01	3.56
	mm	143	80	93	102	90
40	ins.	6.11	3.30	4.38	4.16	4.10
	mm	155	84	111	106	104
41	ins.	7.35	3.63	5.06	4.58	4.71
	mm	187	92	129	116	120
42	ins.	7.35	3.63	5.50	4.58	5.18
	mm	187	92	140	116	132
45	ins.	6.53	3.36	3.75	4.91	3.14
	mm	166	85	95	125	80
46	ins.	6.46	3.36	3.66	4.91	3.56
	mm	164	85	93	125	90
47	ins.	7.03	3.51	4.38	5.06	4.10
	mm	179	89	111	129	104
48	ins.	8.22	3.97	5.06	5.47	4.71
	mm	209	101	129	139	120
49	ins.	8.22	3.97	5.50	5.47	5.18
	mm	209	101	140	139	132

* Valves must be mounted with solenoid vertical and upright.

Constr. Ref. 6, 11, 13, 29

1/2 NPT OR 7/8 DIA HOLE FOR

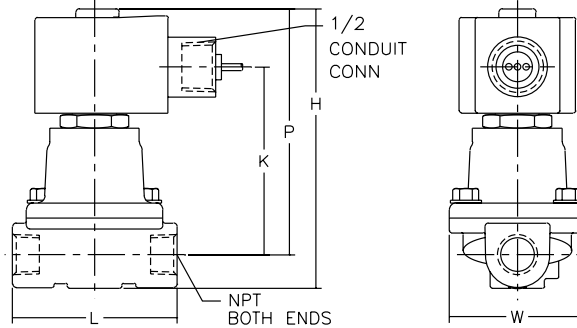

Constr. Ref. 19 *

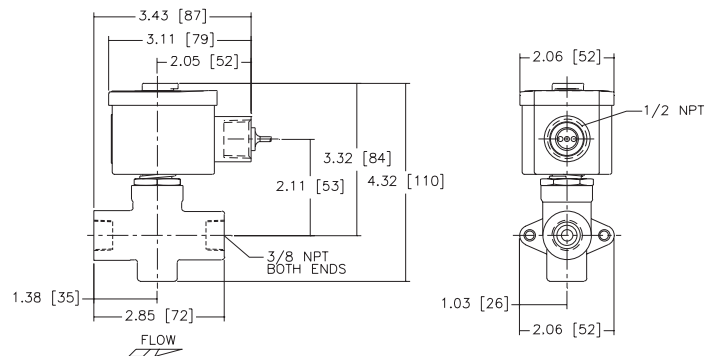

Constr. Ref. 20 *

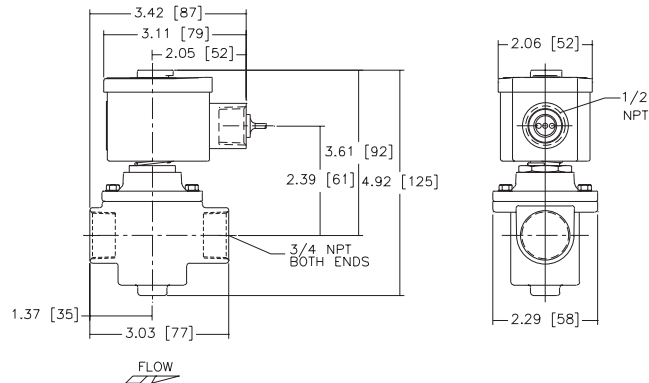

Constr. Ref. 14 - 16, 23 - 25, 45 - 49

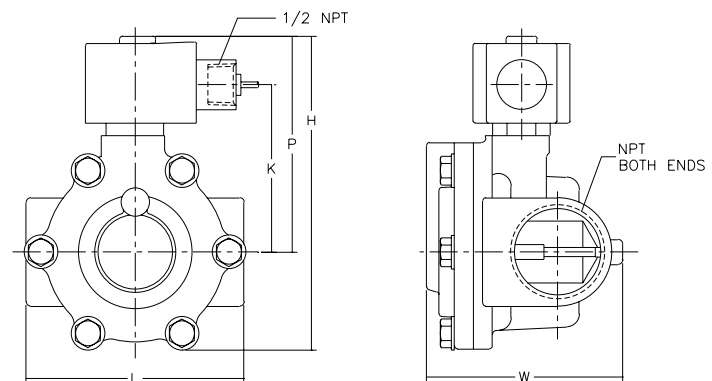

Dimensions: inches (mm)

Const. Ref. No.		H	K	L	P	W
21	ins.	5.11	3.13	2.71	4.35	3.58
	mm	130	80	69	111	91
22	ins.	5.30	3.29	2.78	4.51	3.58
	mm	135	84	71	115	91
28	ins.	4.17	2.47	2.81	3.44	2.28
	mm	106	63	71	87	58
30	ins.	5.82	3.22	3.75	4.19	4.44
	mm	148	82	95	106	113
31	ins.	3.25	1.70	2.00	2.67	1.95
	mm	83	43	51	68	50
36	ins.	4.32	2.69	2.71	3.56	3.45
	mm	110	68	69	90	88
43	ins.	5.12	3.14	2.71	4.35	3.65
	mm	130	80	69	111	93
44	ins.	5.30	3.30	2.78	4.51	3.65
	mm	135	84	71	115	93

Constr. Ref. 17, 18, 26, 27, 38 - 42

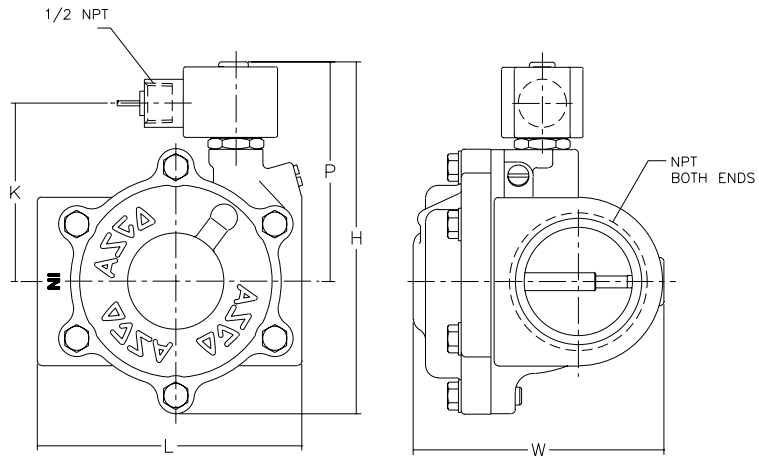

Constr. Ref. 28

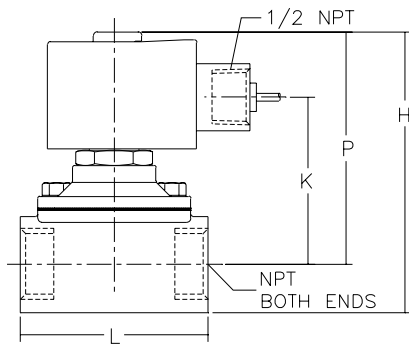

Constr. Ref. 30

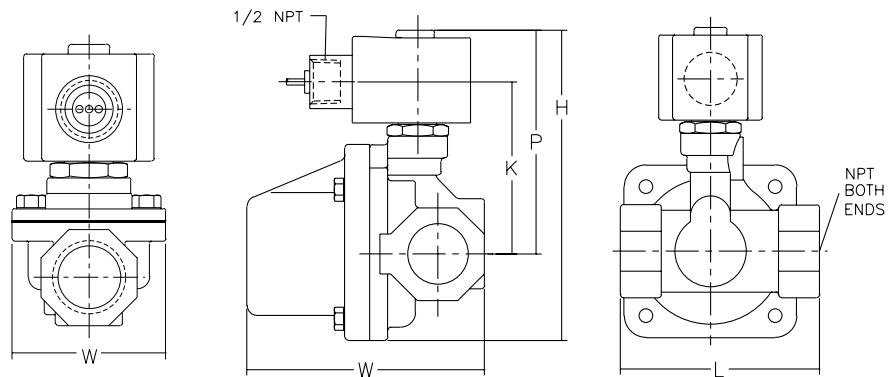

Constr. Ref. 31

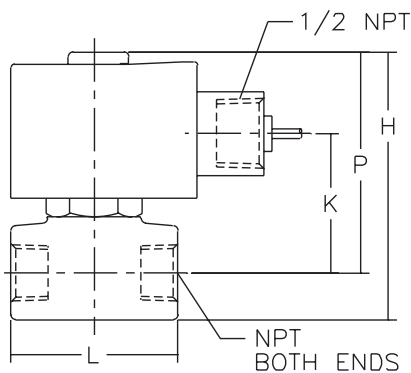

Constr. Ref. 21, 22, 36, 43, 44

