



80-100 Series Bronze LP-Gas Ball Valve

Threaded, 600 psig WOG, Cold Non-Shock. 250 psig LP-Gas.
150 psig Saturated Steam. Vacuum Service to 29 inches Hg.
Federal Specification: WW-V-35C, Type: II, Composition: BZ, Style: 3.
MSS SP-110; Ball Valves Threaded, Socket-Welding, Solder Joint, Grooved and Flared Ends.

FEATURES

- UL Listed for LP-Gas, natural gas, flammable liquid and heated oil
- Large ports to reduce pressure drop
- RPTFE seats and seals
- Blow-out-proof stem design
- Quarter turn On-Off
- Adjustable packing gland
- One piece bronze body
- Chromium plated ball



LISTED

UL LISTINGS

- Guide YSDT: LP-Gas shut-off valve.
- Guide YRPV: Gas shut-off valve for use with natural and manufactured gases.
- Guide YRBX: Flammable liquid shutoff valve.
- Guide MHKZ: No. 6 oil at 250°F.

STANDARD MATERIAL LIST

1. Lever and grip	Steel, zinc plated w/vinyl	6. Retainer	B16 or B584-C84400
2. Stem packing	RPTFE	7. Gland nut	B16
3. Stem bearing	RPTFE	8. Stem	B16
4. Ball	B16, chrome plated	9. Lever nut	Steel, zinc plated
5. Seat (2)	RPTFE	10. Seal	PTFE (1-1/4" to 3")
		11. Body	B584-C84400

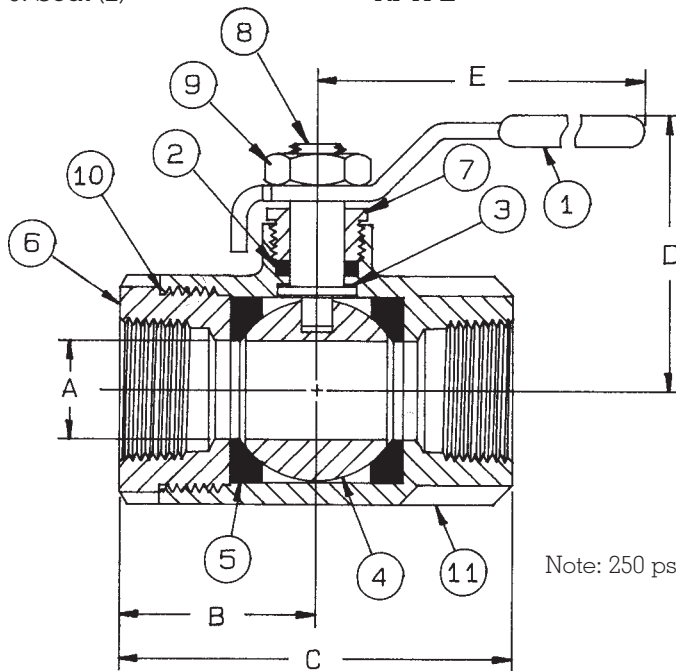

Note: 250 psig Max. UL Listing.

OPTIONS AVAILABLE:

(SUFFIX)	OPTION	SIZES
-27-	SS Latch-Lock Lever & Nut	1/4" to 3"

BRONZE LP-GAS BALL VALVE

NUMBER	SIZE	A	B	C	D	E	Wt.
80-101-01	1/4"	.37	1.03	2.06	1.75	3.87	.60
80-102-01	3/8"	.37	1.03	2.06	1.75	3.87	.56
80-103-01	1/2"	.50	1.12	2.25	1.81	3.87	.63
80-104-01	3/4"	.68	1.50	3.00	2.12	4.87	1.39
80-105-01	1"	.87	1.68	3.37	2.25	4.87	1.72
80-106-01	1-1/4"	1.00	2.00	4.00	2.62	5.50	3.26
80-107-01	1-1/2"	1.25	2.18	4.37	2.87	5.50	4.57
80-108-01	2"	1.50	2.34	4.68	3.06	5.50	5.56
80-109-01	2-1/2"	2.50	3.25	6.50	4.12	8.00	17.25
80-100-01	3"	2.50	3.37	6.75	4.12	8.00	18.60

**For Pressure/Temperature Ratings,
Refer to Page M-8, Graph No. 4**