

## Q7751A Routers



### INSTALLATION INSTRUCTIONS

#### DESCRIPTION

The Q7751A Router doubles the bus length and the number of nodes on the LONWORKS® (E-Bus) network. The Q7751A2010 has an FTT-10 transceiver and is used on LONWORKS networks with the Excel 10 series 2000 family of controllers. The Q7751A1012 has a TP-78 transceiver and is used on LONWORKS networks with the Excel 10 VAV1 series 1000 controllers.

The Q7751A is a two-piece design allowing pre-wiring and cable testing prior to installing the router. The front panel includes a printed circuit board (PCB) with active electronics. It also has a service switch and two service LEDs; a combination power/wink LED, an activity LED and two network connectors. See Fig. 1 for front panel view.

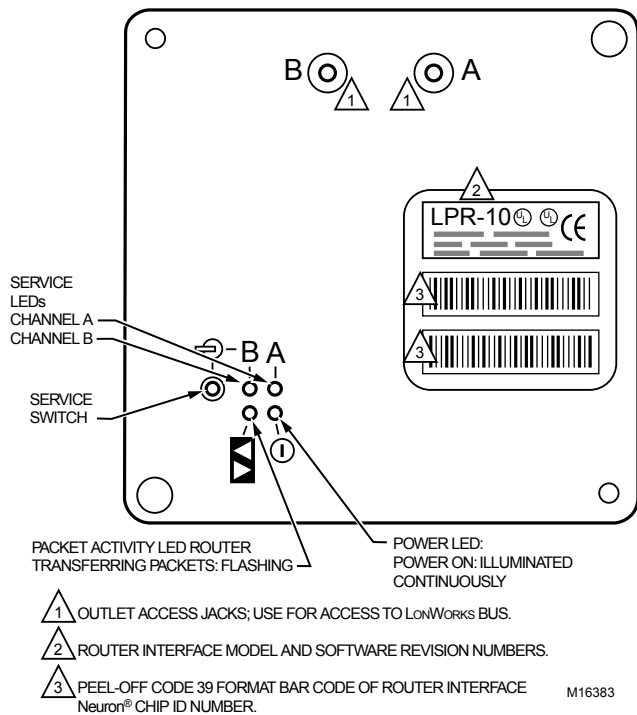
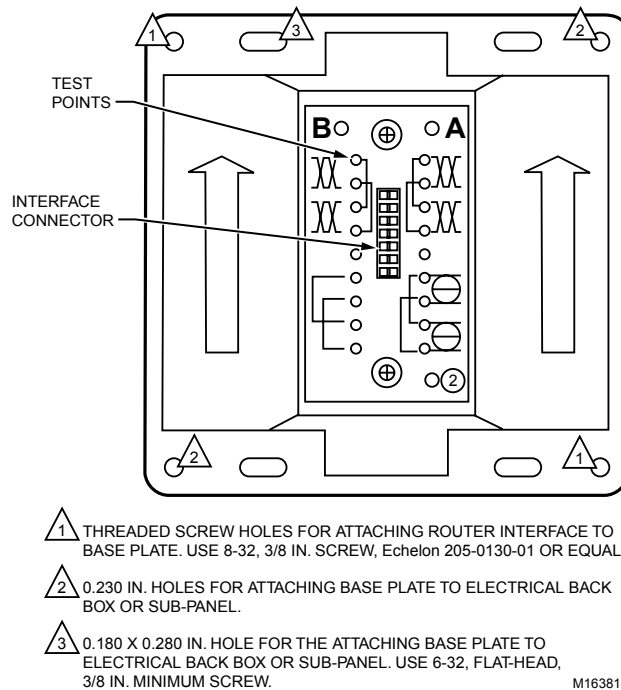

Fig. 1. Q7751A Router front plate.

The router is installed in a Type 2 base plate. Wiring connections are presented in Table 1. Specifications for the router are shown in Table 2. Network and power are connected to screw terminals located on a Type 2 base plate. The router is plugged into the base plate. No wiring is ever connected directly to the router. A writing space is provided on the back of the base plate for recording the date of installation and other important information. See Fig. 2 for front view of base plate. See Fig. 3 for rear view of base plate.



- 1 THREADED SCREW HOLES FOR ATTACHING ROUTER INTERFACE TO BASE PLATE. USE 8-32, 3/8 IN. SCREW, Echelon 205-0130-01 OR EQUAL.
- 2 0.230 IN. HOLES FOR ATTACHING BASE PLATE TO ELECTRICAL BACK BOX OR SUB-PANEL.
- 3 0.180 X 0.280 IN. HOLE FOR THE ATTACHING BASE PLATE TO ELECTRICAL BACK BOX OR SUB-PANEL. USE 6-32, FLAT-HEAD, 3/8 IN. MINIMUM SCREW.

Fig. 2. Q7751A front view of base plate.

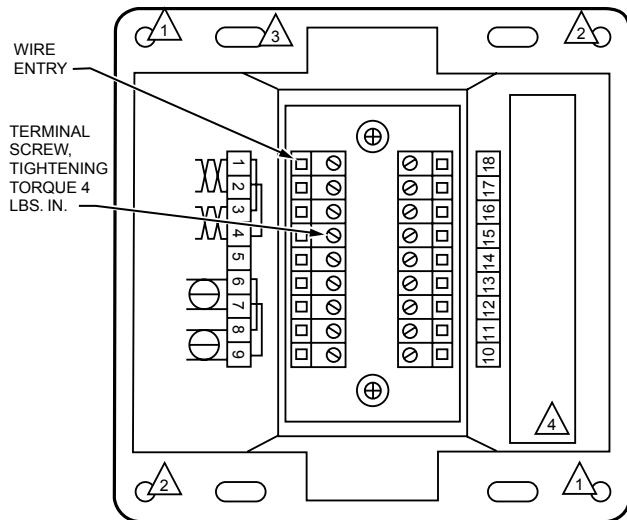

- 1 THREADED SCREW HOLES FOR ATTACHING ROUTER INTERFACE TO BASE PLATE. USE 8-32, 3/8 IN. SCREW, Echelon 205-0130-01 OR EQUAL.
- 2 0.230 IN. HOLES FOR ATTACHING BASE PLATE TO ELECTRICAL BACK BOX OR SUB-PANEL.
- 3 0.180 X 0.280 IN. HOLE FOR THE ATTACHING BASE PLATE TO ELECTRICAL BACK BOX OR SUB-PANEL. USE 6-32, FLAT-HEAD, 3/8 IN. MINIMUM SCREW.
- 4 WRITING SPACE FOR INSTALLER. USE FINE POINT SANFORD SHARPIE MODEL 30001 OR EQUAL.

M16382

**Fig. 3. Q7751A rear view of base plate.**

The Type 2 base plate is keyed to prevent accidental insertion of an incorrect module. The router is attached to the base plate with two 8-32 x 3/8 in. screws (provided). The Type 2 base plate mounts to either a suitable U.S. four in. square, two in. deep (10.16 cm x 5.08 cm) electrical box, U.S. double gang electrical box or an IP-65 (NEMA 4) enclosure. See Fig. 4 and 5.

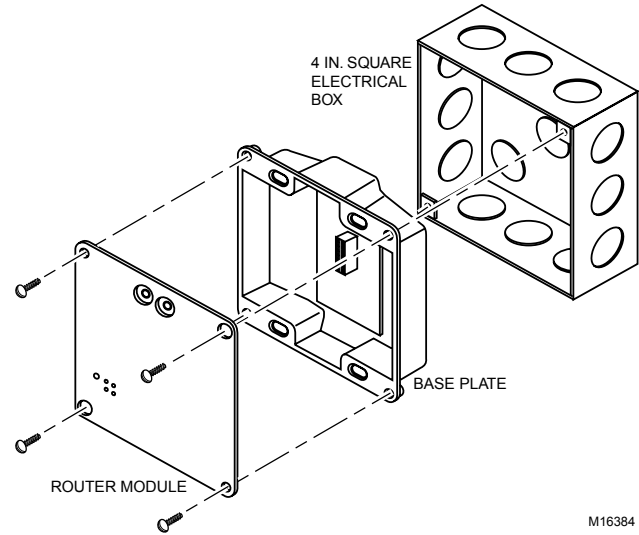

M16384

**Fig 4. Four in. square, two in. deep electrical box mounting configuration.**

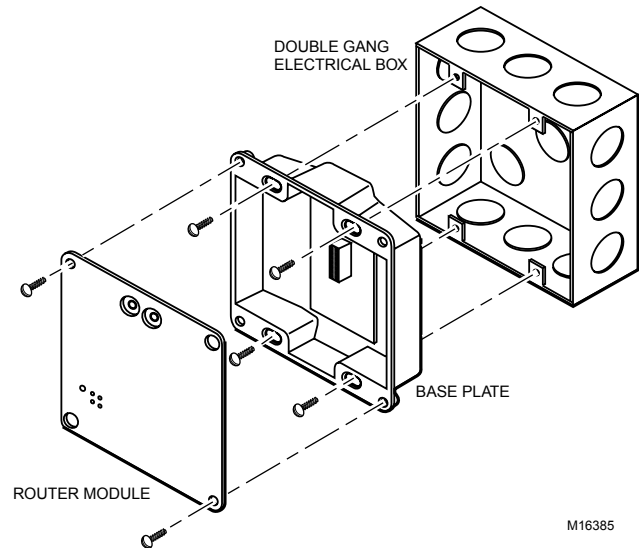

M16385

**Fig 5. Double gang two in. deep electrical box mounting configuration.**

**Table 1. Router Wiring Connections.**

Screw Terminal	Wiring Connection
1 and 2	Incoming network wiring, polarity insensitive; CHANNEL A.
3 and 4	Outgoing network wiring, polarity-insensitive; CHANNEL A.
5 and 14	Cable shields; terminals 5 and 14 are internally connected.
6 and 7	Incoming power wiring 16 to 30 Vac or Vdc at 2.0 VA, polarity-insensitive. If using dc power, maintain continuity of the power polarity throughout the network. Terminals 6 and 8 should be the same polarity. Terminals 7 and 9 should be the same polarity.
10 and 12	Unused Jumpered together internally; can be used to land extra wires.
11 and 13	Jumpered together internally; can be used to land extra wires.
15 and 16	Incoming network wiring, polarity insensitive; CHANNEL B.
17 and 18	Outgoing network wiring, polarity-insensitive; CHANNEL B.

**Table 2. Router Specifications.**

Function	Description
Processor	Two Echelon Neuron <sup>®</sup> 3150 chips. 10 Mhz.
Service function	Recessed service switch, service LED. Dual tear-off bar code Neuron <sup>®</sup> ID self-adhesive tag for application to redline drawings in the field.
Transceiver type	Depends on model. FTT-10 for Q7751A2010 TP-78 for Q7751A1012
Network connector	Ten orange screw terminals, non-removable, wire clamp style. Supports 12 to 24 AWG (4 to 0.27 mm <sup>2</sup> ) wire, shielded or unshielded daisy-chained cable. Two phone plug connectors are front panel accessible; one per channel.
Input power	16 to 30 Vac or Vdc at 2.0 VA, internally isolated power supply.
Power connector	Four black screw terminals, non-removable, wire clamp style. Supports 12 to 24 AWG (4 to 0.27 mm <sup>2</sup> ) daisy-chained wire.
Mounting	Use with suitable back plate. Electrical box type or wall/35 mm DIN type.
Temperature	-40 to +185°F (-40 to +85°C) operating and non-operating.
Humidity	10 to 95% RH at 122°F (50°C).
EMI	FCC A, CE Mark
Safety agency	UL 916

## INSTALLING THE ROUTER

Install the router using the following steps:

1. Make sure the Type 2 base plate is correctly wired, installed, and fastened to the electrical enclosure.
2. Check for continuity on all network and power wiring.
3. Make sure all network channels are terminated with the correct number and type of terminator. Either one or two terminator(s) can be installed in unused screw terminals at the end of a network run.

4. Insert the router into the Type 2 base plate.
  - a. Align the network access jacks on the router with the arrowhead on the Type 2 base plate (the arrow should point toward the jacks).
  - b. Firmly press router into the base plate to make sure the module is properly seated in its base plate connector.

NOTE: The router can be hot plugged. There is no need to disconnect power when installing the module. If power is present, the Power LED lights. If power is not present, the Power LED is off.

5. Screw the two 8-32 x 3/8 in. (9.5 mm) screws into the threaded inserts in the base plate.
6. Configure the router as described in the appropriate software user guide.
7. See Troubleshooting section if necessary.

## TROUBLESHOOTING

Table 3 contains common troubleshooting symptoms and possible reasons and actions for repair.

**Table 3. Troubleshooting symptoms and solutions.**

Symptom	Diagnosis
Power LED lit	This is the normal LED state with node powered.
Power LED unlit	Power supply that provides power to the module has lost primary power. Check power supply outlet for power. Power wiring not correctly connected to module. Use a meter to check for power on base plate power terminals. Input voltage is too low due to excessive load on the power supply that provides power to the module because of excessively long cabling or power wiring that is shorted. Use a meter to check for the correct voltage level on the base plate power terminals. Correct wiring length if too long. Repair or replace faulty power cable.
Service LED unlit	This is the normal state of the LED for a configured module.
Service LED flashing	The module is not configured. This is the normal state for a new module. Commission the module using the software tool.
No network communications	Network wiring not connected correctly to the module. Network cabling shorted, open, or otherwise damaged. Use continuity tester to check cabling. Router(s) on network are not commissioned or powered. Incorrect router channel type installed on channel.
Erratic or improper network communications	Network wiring not securely connected to base plate terminals. The optimum tightening torque for a base plate screw terminal is 4 lb/in. (0.5N/m) maximum. Module not properly seated in the base plate. Make sure the module is pressed firmly into the base plate and secured with fixing screws. Use E-Bus Wiring Guidelines, form 74-2865. Improper network cabling. In some cases, it is possible to correct network communications by installing the Q7740A or Q7740B repeater in series with the network cabling. In other cases, the cabling must be replaced with an approved cable. Too many nodes on a channel. See the appropriate software user guide for channel limitations. Controllers or devices are connected to the wrong channel of a router. Make sure the correct types of controllers or devices are connected to the two router channels.

*LONWORKS® is a registered trademark of Echelon® Corporation.*

## Honeywell

### Home and Building Control

Honeywell Inc.  
Honeywell Plaza  
P.O. Box 524  
Minneapolis, MN 55408-0524

### Home and Building Control

Honeywell Limited-Honeywell Limitee  
155 Gordon Baker Road  
North York Ontario  
M2H 3N7

### Home and Building Control Products

Honeywell AG  
Böblinger Straße 17  
D-71101 Schönaich  
Phone (49-7031) 637-01  
Fax (49-7031) 637-493

