

VU53S; VU54S; VU443A; VU444A; VU843A; VU844A Fan Coil Valves and Actuators

PRODUCT DATA



VU Fan Coil Actuator and Valves

APPLICATION

The VU443, VU444, VU843 and VU844 Fan Coil Valve Actuators are used in conjunction with the VU53 and VU54 valves for controlling the flow of hot or chilled water in commercial HVAC equipment such as fan coil units, terminal reheat coils and convectors. These valves are humidity resistant and are suitable for use in condensing, non-corrosive environments.

IMPORTANT

These valves are not for use in systems containing dissolved oxygen.

FEATURES

- Compact construction for easy installation.
- Fits under the cover of most baseboard convectors with actuator fitted.

ACTUATOR

- One-button, quick release. Secure 3-point, metal latch to valve body.
- Spring return operation.
- Stainless steel case and aluminum cover.
- Line or low voltage, rust-resistant motors.
- Slotted conduit hole for faster wiring.
- Connecting leads available up to 8 feet (2.4m) long.
- Manual opener for valve operation on power failure. Valve returns to automatic position when power is restored.
- Actuator may be reinstalled or serviced without draining the system or disassembling the valve.
- VU443, VU843 actuators fit all 2-way VU53 valve bodies from 1/2" to 3/4".
- VU444, VU844 actuators fit all 3-way VU54 valve bodies from 1/2" to 3/4".

VALVE

- VU53 provides 2-way, straight-through control of water. Available in normally closed or normally open configurations.
- VU54 provides 3-way diverting control of water.
- 300 psi (2,000 kPa, PN20) operating pressure rating.
- Patented ball seal provides long service life, soft close off.
- Triple O-ring seal provides three lines of defence against corrosion and water leakage around driveshaft.
- Quick opening flow curve.
- Choice of sweat brass end connections.

Contents

Application	1
Features	1
Specifications	2
Ordering Information	2
Installation	5
Operation	6
Checkout	7



SPECIFICATION

ACTUATOR

Models:

VU443, VU843: for use with VU53 2-way valves.
 VU444, VU844: for use with VU54 3-way valves.

Actuator Electrical Rating & Connection:

10 VA Maximum

Model	Control Circuit	Current Draw (A)	Connection/Leads	Type
VU443A VU444A	120V, 60Hz	0.07	6" motor leads standard.	2-WAY, Normally Closed; or Open; (VU443A,VU843A)
VU843A VU844A	24V, 50-60 Hz	0.32	18", 36" or 96" Leadwires optional.	3-WAY, Diverting; or Mixing; (VU444A,VU844A)

Note: Motors for all the above models are Class A, Plated.

Maximum Ambient @ Fluid Temperature Rating:

Standard models (with class A motor):
 •104°F(40°C) ambient @ 200°F(94°C) fluid.

Minimum Ambient Temperature:

34°F(1°C)

Shipping and Storage Temperature:

-40°C to 65°C (-40°F to 150°F).

Atmosphere:

Non-corrosive, non explosive, condensing.

Noise Rating:

Low Noise - non obtrusive.

Materials:

Case: stainless steel.
 Cover: aluminum.
 Sector gear: reinforced with KEVLAR®brand fiber.

KEVLAR® is a Dupont registered trademark.

Dimensions:

See Fig. 1.

ORDERING INFORMATION

For ordering information when purchasing replacement and modernization products from your TRADELINE® wholesaler or your distributor, refer to the TRADELINE® Catalog or price sheets for complete ordering number, or specify:

1. Order number.
2. Voltage and frequency.
3. Size and type of end connections.
4. C_v (k_v) rating.
5. Lead length if different from standard.
6. Replacement parts, if needed.

If you have additional questions, need further information, or want to comment on our products or services, please write or phone:

1. Your local Honeywell Home and Building Control sales office (check white pages of phone directory).
2. Home and Building Control Customer Logistics
 Honeywell Inc., 1885 Douglas Drive North
 Minneapolis, Minnesota 55422-4386 (612) 951-1000

In Canada—Honeywell Limited/Honeywell Limitée, 35 Dynamic Drive, Toronto, Ontario M1V 4Z9. International Sales and Service Offices in all principal cities of the world. Manufacturing in Australia, Canada, Finland, France, Germany, Japan, Mexico, Netherlands, Spain, Taiwan, United Kingdom, U.S.A.

VALVE

Models:

VU53: 2-way, normally closed valves.
 VU54: 3-way diverting valves.

Valve Styles, Sizes, Flow Capacity Rating (C_v) & Maximum Close-off Pressure Rating (psi):

Pipe Connections				Flow Capacity Rating		Maximum Closeoff Pressure*	
Model	Type	End Fittings	Size	C _v	k _v	psi	kPa
VU53S	2-WAY Normally Closed	SWEAT	1/2"	3.5	3.0	20	138
			3/4"	3.5	3.0	20	138
			3/4"	8.0	7.0	10	69
VU54S	3-WAY Diverting	SWEAT	1/2"	4.0	3.4	20	138
			3/4"	7.0	6.0	12	83

Max. Fluid Temperature:

Standard Models (with Class A motor):
 •200°F(94°C) fluid @ 104°F(40°C) ambient.

Min. Fluid Temperature:

34°F(1°C) for all models.

Max. Operating Pressure Rating:

300 psi (2000 kPa), PN20.

Flow Characteristics:

Quick opening for on-off application.

Material:

Valve body: forged brass.
 Drive shaft stem: brass.
 Ball plug: Buna-N rubber.
 O-ring seals: EPDM rubber.

Service Medium:

Suitable for hot and chilled water with up to 50% glycol.

Dimensions:

See Fig. 1.

Approvals:

CSA C/US Certified.

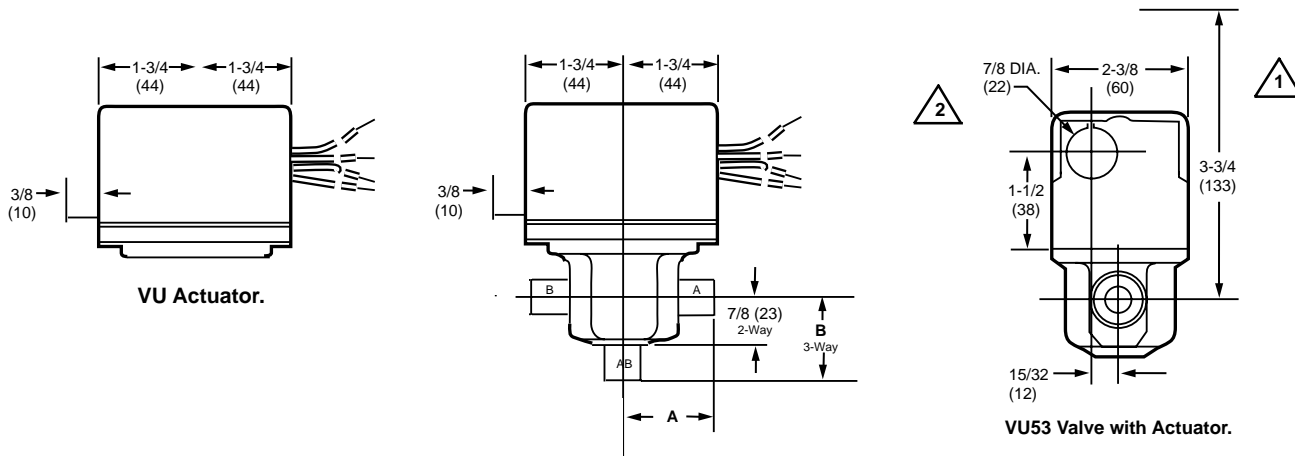

VU53 and VU54 Valve Dimensions with Actuator.

VALVE BODY SIZE	A	B
1/2" Sweat	1-5/16 (33)	1-5/16 (33)
3/4" Sweat	1-3/8 (35)	1-11/16 (43)

- 1 HEIGHT NEEDED TO REMOVE ACTUATOR OR COVER.
- 2 OPENING FOR 1/2 IN. CONDUIT ON OPPOSITE SITE OF MANUAL LEVER FOR ALL MODELS.

Fig. 1: Mounting Dimensions in in. (mm).

How to Find Valve Pressure Drop

ANSI units

The pressure drop in psi, or feet of water can be calculated from Fig. 2 as follows:

1. Calculate the flow rate to cool and dehumidify.
2. Determine the C_v rating of the valve.
3. Select the graph corresponding to the C_v rating of the valve.

4. Determine the pressure drop across the valve using the following procedures for calculating pressure drop.
 1. Locate the flow rate at the bottom of the graph.
 2. Draw a line up from the flow rate to the intersection of the curve.
 3. Draw a line from the intersection to the left edge of the graph to determine the pressure drop in psi, or to the right edge to determine the pressure drop in feet of Head. (Pressure drop in feet of Head = psi X 2.2.)

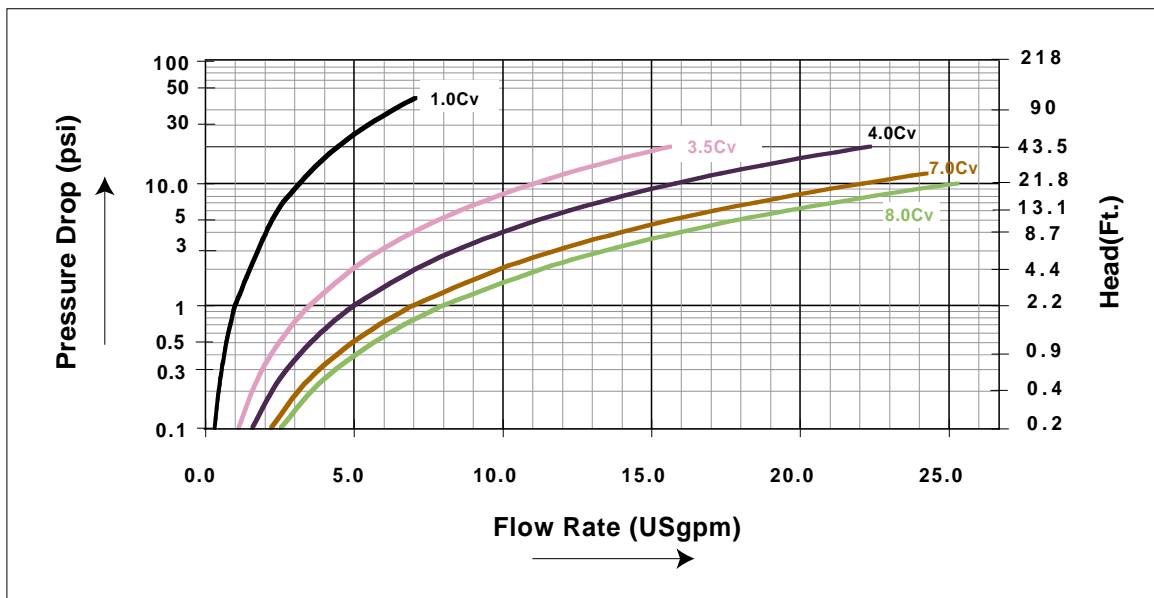

Fig. 2. Flow characteristics of VU53, VU54 valves, ANSI units.

How to Find Valve Pressure Drop

SI (metric) units (Fig.3)

1. Calculate desired flow through valve in m³/h or litres/second. L/s = 3.6 X m³/h.
2. Determine the k_v rating of the valve.
3. Select the graph corresponding to the k_v rating.
4. Determine the pressure drop across the valve by:
 1. Locate the flow rate (in m³/h on the left edge of the graph).
 2. Draw a line from the flow rate to the intersection of the k_v line.
 3. Draw a line from the intersection to the bottom to determine the pressure drop in kPa or Bar.

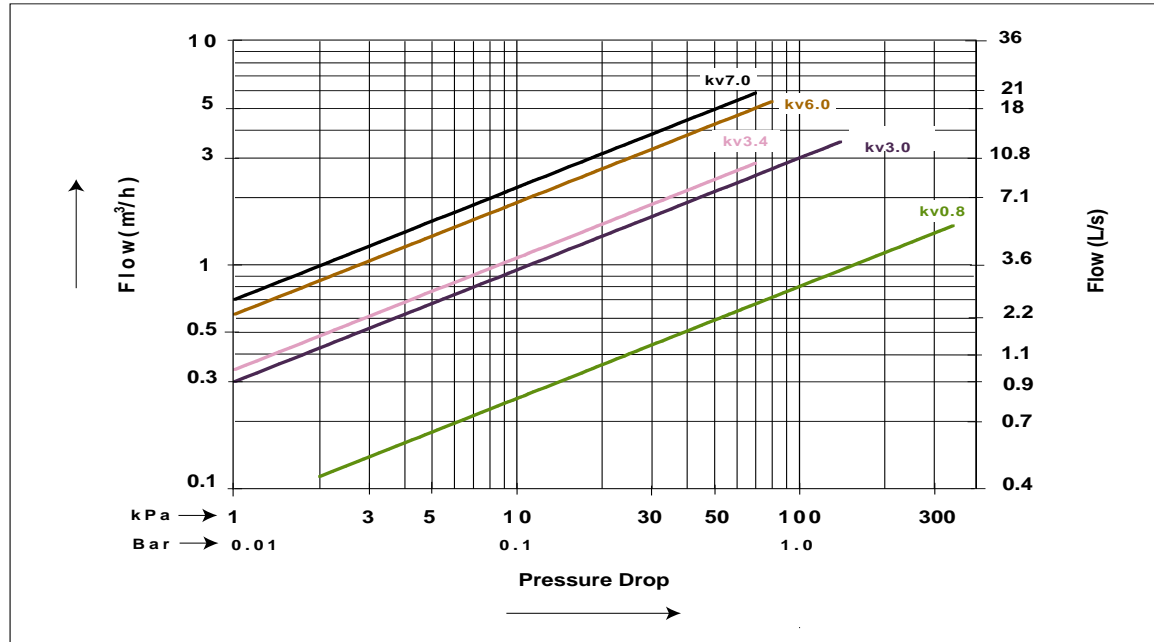

Fig. 3. Flow characteristics of VU53, VU54 valves, SI units.

INSTALLATION

When Installing this Product...

1. Read these instructions carefully. Failure to follow them could damage the product or cause a hazardous condition.
2. Check the ratings given in the instructions and on the product to make sure the product is suitable for your application.
3. Installer must be a trained, experienced service technician.
4. After installation is complete, check out product operation as provided in these instructions.

CAUTION

1. Disconnect power supply before connecting wiring to prevent electrical shock or equipment damage.
2. On 24V systems, never jumper the valve coil terminals even temporarily. This can burn out the heat anticipator in the thermostat.
3. **Wear safety glasses to protect eyes from injury when removing or installing the large spring clip that holds the actuator mounting plate to the valve body.**
Use proper snap ring pliers to remove or install spring clip.

Mounting

The valve can be mounted in any position on a vertical line. See Fig. 5. If the valve is mounted horizontally; the actuator must be even with or above the center line of the piping. Make sure to leave enough room above the actuator to remove the cover or actuator for servicing. Mount the valve directly in the tube or pipe. **Make sure that the flow through the valve is in the direction indicated by the arrow stamped on the valve body.**

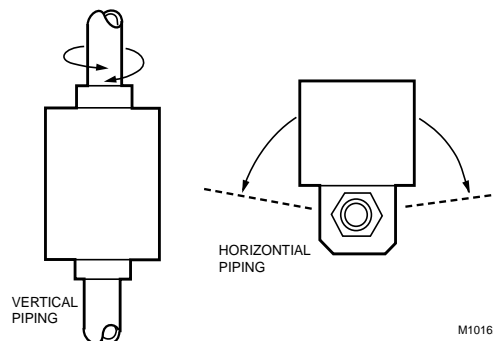

Fig. 5 Mounting positions.

On diverting valves, the three fittings or ports are labeled on the bottom of the valve body casting. Port AB is the inlet port and is open at all times. Port A is closed and port B is open when the valve is de-energized. Refer to the equipment manufacturer instructions to determine which port (A or B) should be connected to the coil bypass.

Sweat Copper Models

1. Use new, properly reamed pipe, free from dents or corrosion.
2. Place the valve on the pipe. **Rotate valve stem** so that the shaft slot points at the notch in the side of the body (90° to flow directions.) See Fig. 6. This protects the plug inside the valve by removing it from the seat.
3. Sweat the joints, keeping the outer surface free from solder. **DO NOT use silver solder** because of the high melting temperature required.

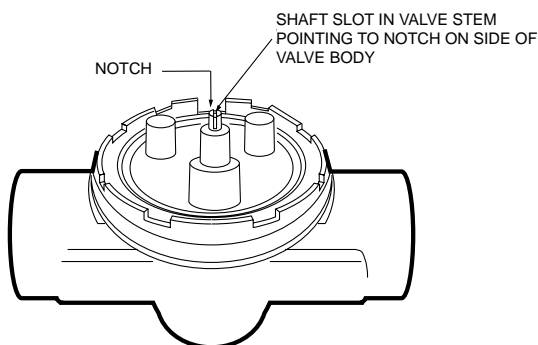

Fig. 6 Slot position.

To Install & Remove Actuator

INSTALLING ACTUATOR ON VU-SERIES VALVE BODY ASSEMBLY(See Fig. 7) :

1. **Orient slot in shaft of VU-series valve body toward notch in side of body (i.e. 90° to water flow.)** See Fig. 7. This lifts the ball off seat, prevents damage to the ball seat while soldering, and makes actuator attachment easier.
2. Install valve body into pipe.
3. Wiring connections may be made either before or after actuator installed on valve body.
4. **Place manual operating lever on the actuator in the MAN. OPEN position.**
5. Line up motor coupling to slot in shaft of body and fit the head onto the valve body, ensuring that the shaft seats correctly. (See Fig. 7)
6. Snap actuator onto body by pressing down.
7. Make wiring connections. Refer to wiring section for proper instructions.

Inspect the actuator installation and the valve body to ensure that all connections and adjustments have been correctly made. Adjust the thermostat or controller connected to the valve so that the valve runs through its cycle. Make sure the valve runs smoothly and positively from closed to open to closed again.

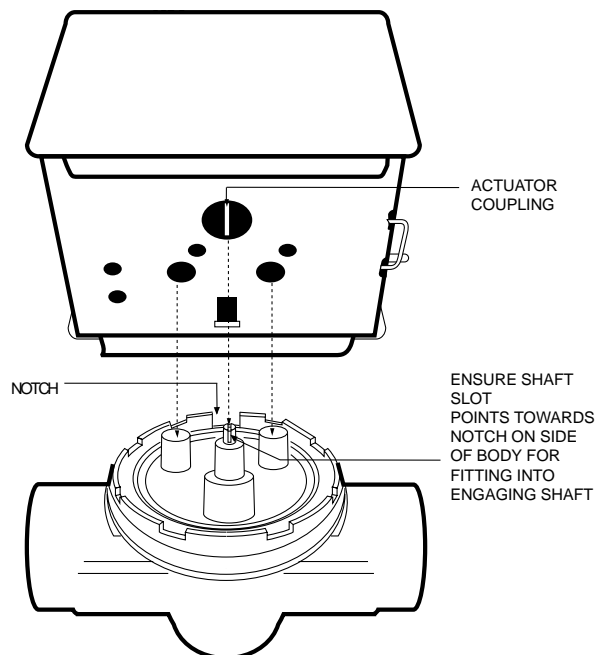

Fig. 7 Installing new actuator.

REMOVING ACTUATOR FROM THE VU-SERIES VALVE BODY ASSEMBLY (See Fig. 8):

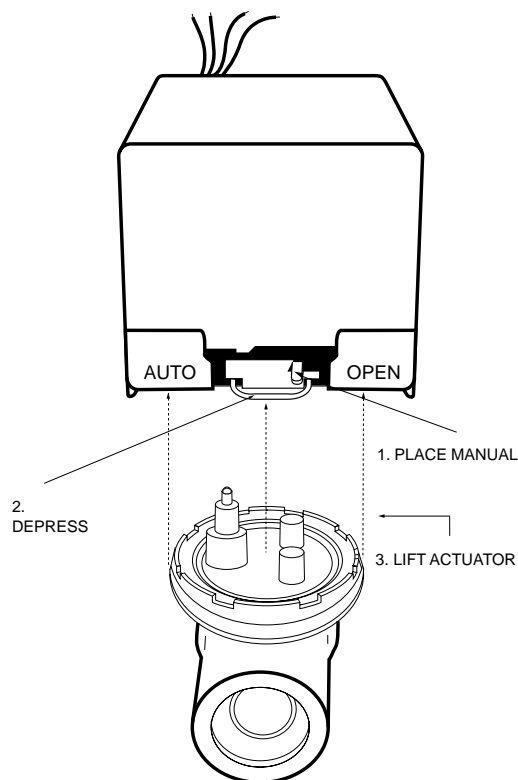

Fig. 8 Removing actuator from valve

NOTE!

It is not necessary to drain the system if the valve body assembly remains in the pipeline.

1. Switch power supplies OFF. Disconnect electrical leads, carefully noting the position and colour of each lead.
2. Place the manual operating lever in the MAN. OPEN position. See Fig. 8.
3. Remove actuator by depressing locking button and lifting straight up.

Wiring

Disconnect the power supply before connecting wiring to prevent electrical shock or equipment damage. All wiring must comply with local codes and ordinances. See Fig. 9 and 10 for typical hookups.

TO ATTACH FLEXIBLE CONDUIT

1. Strip cable jacket.
2. Fit conduit strain relief onto cable.
3. Slide strain relief nut over wires.
4. Connect cable and actuator wires.
5. Slide cable wires down through slot in the wiring hole, so that the strain relief nut is inside the actuator housing.
6. Secure nut onto strain relief.
7. Install actuator cover.

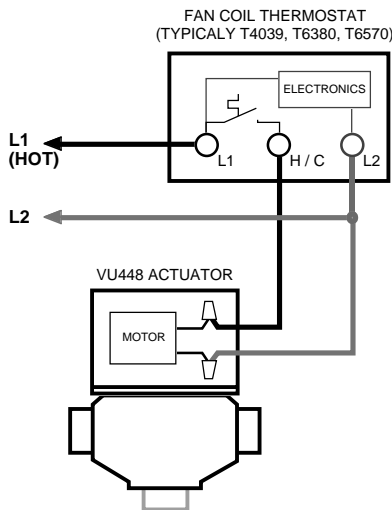

Fig. 9 Typical wiring for VU440-series actuator.

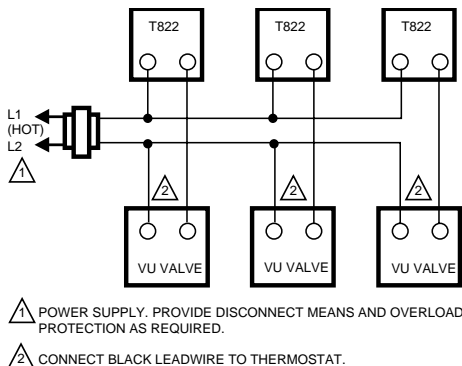

Fig. 10 T822 Thermostat, VU80-series actuator hookup.

OPERATION

CAUTION

ON 24V SYSTEMS, NEVER JUMPER THE VALVE COIL TERMINALS EVEN TEMPORARILY. THIS CAN BURN OUT THE HEAT ANTICIPATOR IN THE THERMOSTAT.

Automatic Operation

On a call for heat or cool by the fan coil thermostat, the valve motor operates, opening the valve. When the call ends, the valve closes by integral spring return.

Manual Operation

The 2-way normally closed and 3-way motorized valve actuators can be opened manually by lifting the manual opening lever over the stop and pushing slowly and firmly to the MAN. OPEN position. The stop permits the valve to be locked in the open position. The valve returns to automatic position when it is energized.

Normally Closed Models

With the manual opener set to AUTO and the actuator energized, the A port is opened as shown in Fig. 11A and 12A. When the actuator is de-energized, a spring-return mechanism drives the valve to the port A closed position as shown in Fig. 11B and 12B. The valve can also be opened with no electrical power by moving the manual opening lever over the stop and pushing slowly and firmly to the MAN. OPEN position. The stop permits the valve to be locked in an open position. The valve returns to the automatic position

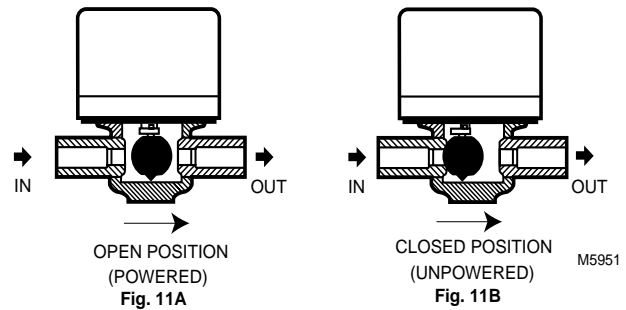

Fig. 11 Actuator operation for normally closed 2-way valve.

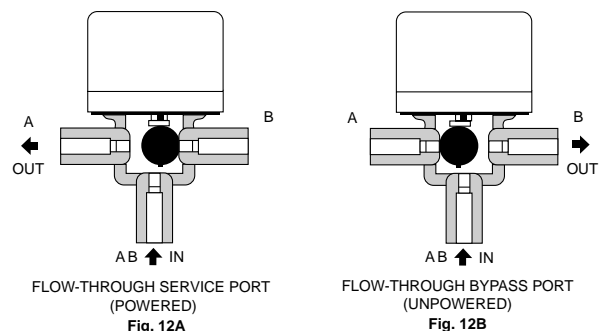

Fig. 12 Actuator operation for normally closed 3-way valve.

CHECKOUT

Set to heating mode

1. Raise the setpoint on the zone thermostat above the room temperature to initiate a call for heat.
2. Observe all control devices—the valve should open.
3. Lower the setpoint on the zone thermostat below the room temperature.
4. Observe the control devices. The valve should close.

Set to cooling mode

1. Lower the setpoint on the zone thermostat below the room temperature to initiate a call for cooling.
2. Observe all control devices—the valve should open.
3. Raise the setpoint on the zone thermostat above the room temperature.
4. Observe the control devices. The valve should close.

SERVICE

This valve should be serviced by a trained, experienced service technician.

1. If the valve is leaking, drain the system and check to see if the O-ring needs replacing.
2. If the gear train is damaged, replace the entire actuator. See the Installation section. If the motor is burned out, replace the motor.

NOTE: Honeywell fan coil valves are designed and tested for silent operation in properly designed and installed systems; however, water noises can occur as a result of excessive water velocity or piping noises can occur in high temperature (higher than 212°F (100°C)) systems with insufficient water pressure. Valves are designed for normal cycling operations. Product life will be shortened if energized continuously.

Home and Building Control

Honeywell Inc.
Honeywell Plaza
P.O. Box 524
Minneapolis MN 55408-0524

Honeywell Latin American Division

Miami Lakes Headquarters
14505 Commerce Way Suite 500
Miami Lakes FL 33016

Home and Building Control

Honeywell Limited-Honeywell
Limitée
35 Dynamic Drive
Scarborough, ON M1V 4Z9
Canada

Honeywell Europe S.A.

3 Avenue du Bourget
B-1140 Brussels Belgium

Honeywell Asia Pacific Inc.

Room 3213-3225
Sun Hung Kai Centre
No. 30 Harbour Road
Wanchai
Hong Kong

