

These electric actuators can be used to control dampers, valves, or other devices that require high torque.

This General Instruction Sheet is concerned with all MC, MF, and MP-9000 actuators.

PRE-INSTALLATION

The MC, MF, and MP-9000 are shipped without mounting hardware or linkage. In damper applications, crank arms (AM-392) and connecting links (AM-394) will be required. In valve applications a valve body and AV linkage will be required.

Before installing the actuator, check for bent or broken parts and oil leaks. Actuators may be connected to power supply to check operation prior to installation. See CHECKOUT.

Potentiometer: Only MP-9000 series actuators include a potentiometer. Standard resistance is 100 ohms. The active winding of the potentiometer is normally spread over 180° or 90° depending upon the limits of shaft rotation. The wiper arm of the potentiometer is connected to the main output shaft through a slip clutch arrangement. When the shaft travels beyond the spread of the potentiometer winding, the wiper arm will cease to rotate once it has hit the stop. It is not damaged, and will instantly start moving in the opposite direction when the shaft reverses direction.

INSTALLATION

Requirements

Preferred mounting for the actuator is in the upright position, but other positions are acceptable. Allow 10 inches clearance above the actuator wiring compartment. The base of the actuator may be used as a template for marking mounting holes.

The current draw of MP and MF actuators with a second digit of 2, 4, 6, or 8 is greater than the Microtherm contact rating. Therefore, a (AM-345) relay is required. See Figure 5 for typical wiring.

Procedure

Make all electrical connections in accordance with the job wiring diagrams and in compliance with national and local electrical codes.

Low and Line Voltage: All wiring to actuator and inside wiring compartment must be connected per Class I circuits.

For 24 Vac power wiring to H and G terminals, use No. 14 wire on runs up to 64 feet and No. 12 wire up to 100 feet. For longer runs or runs to more than one actuator, select wire size for maximum drop of 1.2 volts.



* MP-9700
 MP-9710
 MP-9730
 MP-9750
 Series
 only

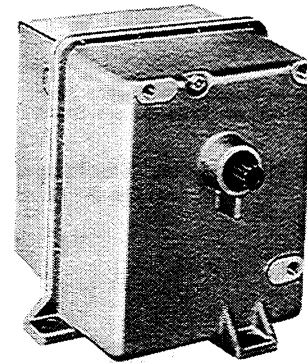
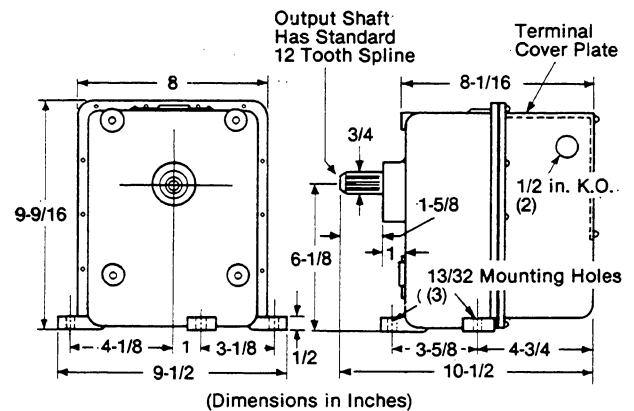

Figure 1.



(Dimensions in Inches)

Figure 2.

Linkage: For linkage where the actuator stroke is 180° and the driven stroke 90°, proceed as follows: (See Figure 6).

1. Mount crank arm on the driven shaft so the linkage connector, in full closed and full opened positions (points C1 and C), will fall on a straight line through the center of the actuator shaft.
2. Secure one end of the connecting link in the driven linkage connector.
3. With crank arm mounted loosely on actuator shaft and actuator at closed position, fasten linkage connector at about mid-position of crank arm slot. Move driven crank arm between full open and full closed positions. If radius of actuator crank is .707 times the radius of driven crank, 180° movement of actuator crank arm will position driven shaft 90°.
4. Move driven crank arm to the closed position and hold firmly in place. Secure crank on actuator shaft (point A) and linkage connector so that points A, B and C1 are in a straight line.
5. Check adjustment for proper operation by running actuator and driven shaft several times between opened and closed positions.

Note: If driven crank arm does not provide tight closing, run actuator a few degrees away from closed position and reset connecting link in driven linkage connector. Driven crank arm will then provide closing under slight pressure. **Never attempt to turn the actuator shaft with a wrench or a crank** — this may damage actuator gears.

TYPICAL EXTERNAL WIRING

MP-9200, 9400, 9600 and 9800 SERIES

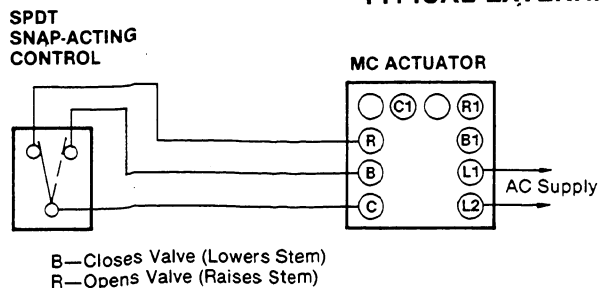

Figure 3. Two-Position Three Wire Oil-Submerged Actuator for On-Off Control

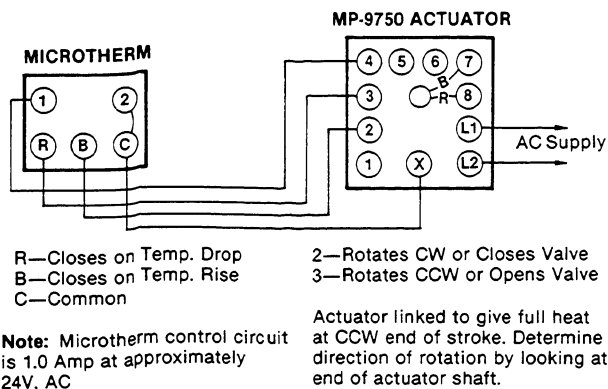

Figure 4. Proportional Oil-Submerged Line Actuators with Internal Transformer (Controlled by Microtherm)

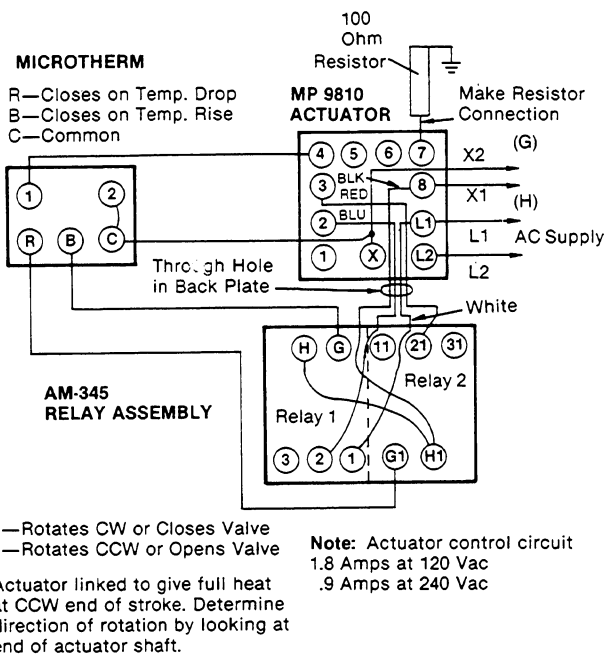

Figure 5. Proportional High Torque Industrial Actuators (Controlled by a Microtherm)

Electrical Rating for Auxiliary Switch	120 Volts	240 Volts
Running Current	5.8	2.9
Locked Rotor	34.8	17.4
Non-Inductive	12	6

Auxiliary switch terminals are C1, B1, R1 on MC units and 1, 5, 6 on MF and MP units except on 5 position units.

PERFORMANCE DATA

Part Number	Type	Input		No Load Timing (secs.)	Rated Torque (lb-in.)	Travel Limit Switch	Aux. Switch	Ambient Temp. Limits (°F)	Misc.
		Volts 60 Hz	Amps						
MC-9610**	Two-position	120	1.8*	65	1100	180° CW only	SPDT	-40 to 130	—
MC-9810**	Two-position	120	1.8*	115	1300	180° CW only	SPDT	-40 to 130	—
MP-9700**	Prop. or Floating	120	0.9	135	800	180° reversible	Five-position	-40 to 130	Built-in Trans. <input type="checkbox"/>
MP-9710**	Prop. or Floating	120	0.9	135	800	180° reversible	SPDT	-40 to 130	—
MP-9713	Prop. or Floating	24	4.0	135	800	180° reversible	SPDT	-40 to 130	—
MP-9750	Prop. or Floating	120	0.9	135	800	180° reversible	SPDT	-40 to 130	Built-in Trans. <input type="checkbox"/>
MP-9810†	Prop. or Floating	120	1.8	115	1300	180° reversible	SPDT	-40 to 130	—
MP-9830†	Prop. or Floating	120	1.8	60	1300	90° reversible	SPDT	-40 to 130	—
MP-9910†	Prop. or Floating	120	1.8	145	1600	180° reversible	SPDT	-40 to 130	—

* Minimum contact rating of controller 1.8 amps at 120 Vac.

** Actuators are obsolete.

† Requires AM-345 relay with microtherm control.

Units with a "-2" suffix, e.g., MP-9750-0-2, include built-in transformer with secondary leads wired externally to terminals 7 and 8. Red (24V) to 8 and Blue (12V) to 7. When these units are used with CC or CP electronic controllers, disconnect R and B leads and tape off.

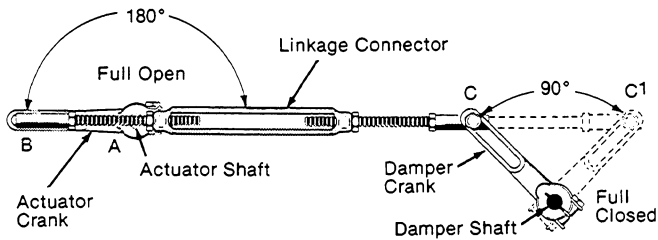

Figure 6.

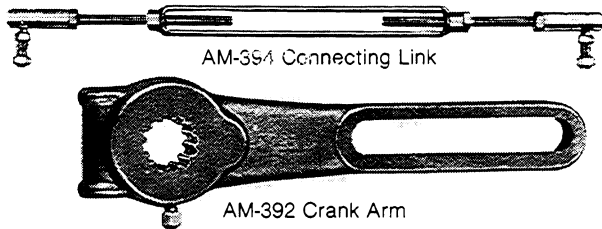

Figure 7.

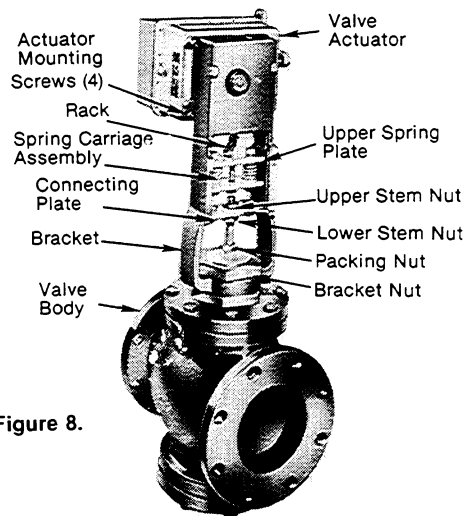

Figure 8.

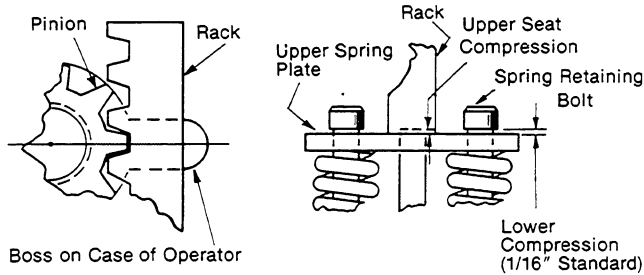

Figure 9.

Figure 10.

Valve Installation: Install all globe type valves with pressure under seat except where a flow direction arrow on the valve body indicates otherwise. Make sure 3-way valves are piped as mixing or diverting valves according to the internal construction of the valve.

Note: Do not tamper with springs or spring carriage settings. These are critical and are factory set.

To remove actuator from valve assembly:

1. Run actuator to release stem compression (Figure 10).
2. Loosen four actuator mounting screws.
3. While supporting actuator, remove screws and disengage pinion from rack. Remove pinion and washer from shaft.

To mount preassembled actuator and linkage assembly on valve:

1. Run actuator to closed (stem down) position.
2. Remove bracket nut from valve.
3. Screw lower stem nut to bottom of threads on stem.
4. Place complete actuator and linkage assembly over valve stem and bonnet until stem extends through hole in connecting plate. Rotate actuator and linkage assembly to desired position and secure with bracket nut.
5. Tighten lower stem nut up against connecting plate.
6. Set compression.

To set compression:

1. If upper stem nut is on valve, loosen or remove. Run actuator clockwise to closed position. Tighten lower stem nut up against connecting plate taking up all play in linkage.
2. Screw upper stem nut on stem 1-1/16-inch from connecting plate for compression on lower seat.
3. Run actuator counterclockwise until connecting plate is tight against upper stem nut. Secure lower stem nut against connecting plate.

To mount linkage assembly on valve:

1. Remove bracket nut from valve and screw lower stem nut down to bottom of threads on stem.
2. Place rack and spring carriage in bracket such that stem extends through connecting plate.
3. Align bracket so position indicator faces desired direction; then tighten bracket nut.
4. See actuator mounting instructions for further instructions.

To mount actuator on linkage assembly:

1. Determine lift of valve by measuring total movement of stem.
2. Set shaft travel to correspond with valve lift. (Note: One degree of shaft rotation is equal to 0.011 inch of stem lift.) Set shaft travel by inserting screwdriver in hole in front of terminal block and engage with notched cam. Turning cam clockwise, as seen from front of actuator, increases shaft rotation. Each click of cam represents approximately 3° shaft rotation. On three-way valves only, add 5° rotation to total shaft travel to provide compression on upper seat.
3. With actuator in full clockwise (closed) position, rotate motor pinion until a pinion tooth lines up with center lines of boss (Figure 9) on actuator case; slide washer and pinion on shaft. Mark this tooth for future reference.
4. Looking at front of linkage (position indicator side), rotate rack until teeth point to the left.
5. Align actuator so that marked tooth of pinion engages with third tooth space from top of rack. Mount actuator to linkage with the actuator mounting screws (4). Apply "Loctite", Grade CV, to screw threads.
6. If necessary to mount indicating strip on bracket, align "CLOSED" position with pointer when actuator is in full closed position. Run actuator full open. Cut out center section of indicator strip so that the "OPEN" position is aligned with pointer.

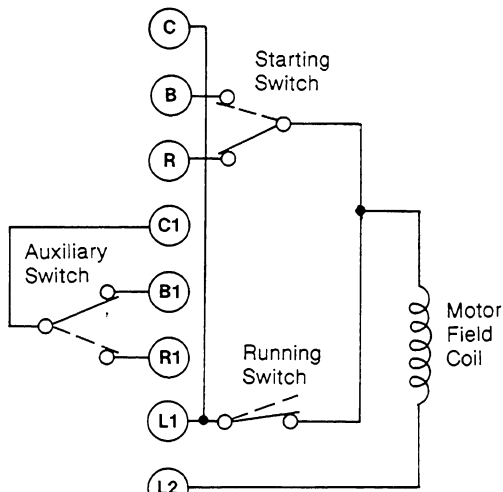

Figure 11.
Two-Position (MC Type)

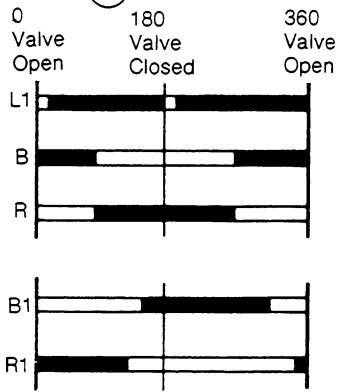

Figure 13. Proportioning and Floating
(MF and MP-9300 and MP-9700 Series Only)

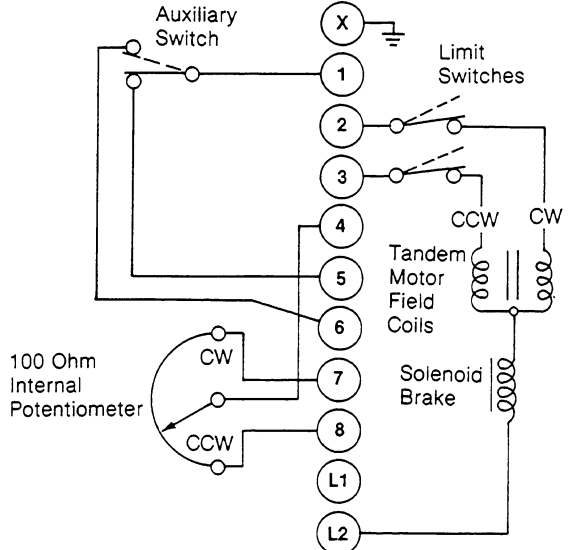
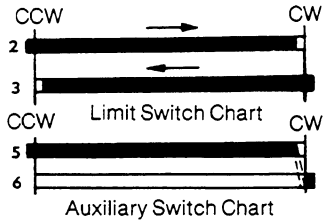
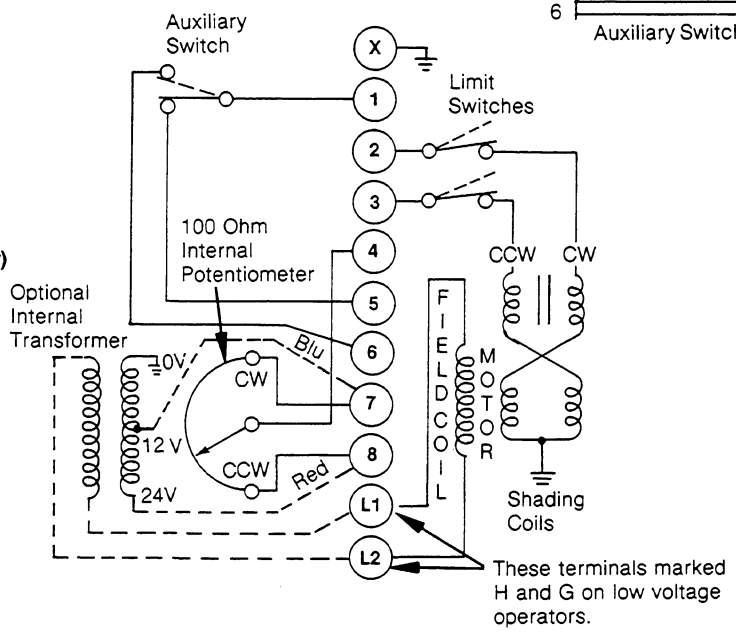
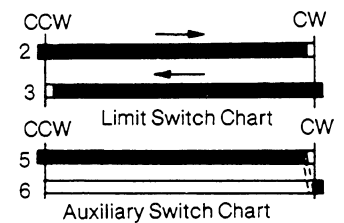

Figure 12.
Proportioning and Floating
(All MF or MP Except
-9300 and -9700 Series)



These terminals marked H and G on low voltage operators.

CHECKOUT

After the entire system has been installed, the following checks for proper system operation may be used.

1. Be sure that the system power is connected and on.
2. Turn the thermostat to call for heat. Actuator should rotate from clockwise to counterclockwise end of travel and turn on heating media. Direction of rotation of the actuator is determined by looking at the end of the output shaft. Actuator is at full clockwise position when the mark on the shaft is at the nine o'clock position.
3. To check actuator operation, disconnect controller and proceed as follows:

MC-9000, Figure 11 — Connect terminal C to B and actuator should run clockwise to end of travel (usually 180°). Connect terminal C to R and actuator should run from 180° to 360° (or 0). Caution: 120 volts.

MF and MP-9700 Series, Figure 13 — Connect terminal 2 to case ground and actuator should run clockwise to end of travel. Connect terminal 3 to case ground and actuator should run counterclockwise to end of travel.

All MF or MP Except 9300 and 9700 Series, Figure 12 — Apply rated line voltage to terminal L2 and terminal 2 for clockwise end of travel. Apply rated line voltage to L2 and terminal 3 for counterclockwise travel to end.

4. To check compression — Lower Seat: Run actuator to full closed (clockwise) position. Measure distance between head of spring retaining bolt and upper spring plate. Upper Seat (3-way Valves Only): Run actuator to full open (counterclockwise) position. Measure distance between bottom of rack and upper spring plate. To change compression on upper seat, adjust travel of actuator shaft. Standard spring compression is 1/16-inch.

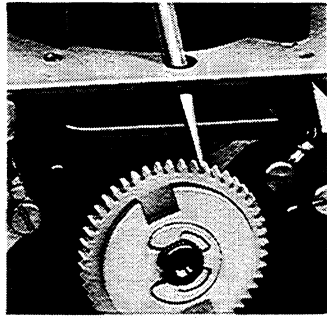

Figure 14.

RUN/ADJUST

Internal Wiring Information

Adjustments

Actuator variations are shown in the internal diagrams (see Figures 11, 12 and 13.)

Auxiliary Switch Adjustment: The adjustable built-in SPDT switch is actuated by the cam nearest the back of the actuator. It is factory set to operate at the clockwise end but may be changed by inserting a screwdriver through the opening in the top plate directly behind the terminal block, and engaging the screwdriver with a gear-like plastic disc (Figure 14). Turning the disc clockwise (as seen from the front of the actuator) causes the switch to operate nearer the counterclockwise end of shaft rotation. Each click of the cam represents an approximate 3° change in operating point. Auxiliary switch electrical rating is shown on the Switch Performance Chart.

Note: When shaft travel has been increased beyond 180° the auxiliary switch may, depending on its actuating point, operate twice in a given shaft stroke. For this reason, the auxiliary switch should be employed with extreme caution where more than 180° of shaft rotation is used.

Limit Switch Adjustment: The counterclockwise limit switch of all actuators is adjustable. Factory setting is usually for 180° of shaft rotation. This setting can be changed in the field by inserting a screwdriver through the opening in the top plate directly ahead of the terminal block and engaging the screwdriver with the notched cam nearest the front of the actuator. Turning the cam clockwise (as seen from the

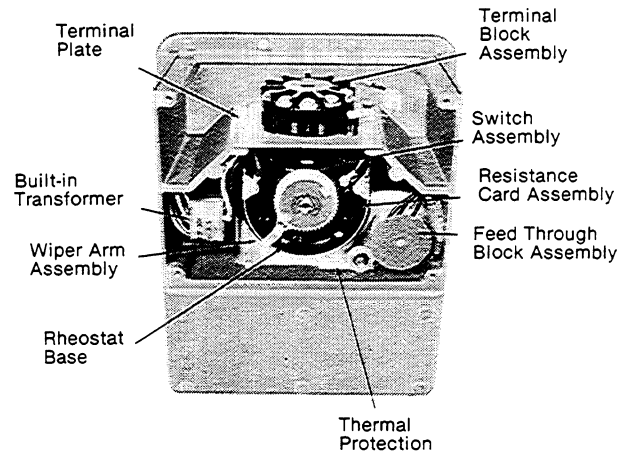

Figure 15.

front of the actuator) increases the length of shaft rotation up to a maximum of 320°. Each click of the cam represents an approximate 3° change in shaft rotation. Attempting to adjust for more than 320° rotation will result in both limit switches opening at the clockwise end of the shaft rotation, and the unit will no longer operate. The clockwise limit switch is fixed and cannot be field adjusted. However, note that a small change in the (clockwise) limit switch setting will result from any movement of the motor top plate, which supports the terminal block.

MAINTENANCE

A minimum of maintenance is required since the motor and gear train are submerged in oil for continuous lubrication and cooling. If necessary to refill the actuator with oil, always use Barber-Colman immersion oil, which is available in quart or one-gallon cans (refill capacity—one gallon). For best performance, oil level (with actuator upright) should be up to the edge of the oil-fill hole which is located in the front case of the actuator.

REPAIR

Normally actuators are returned to the factory for reconditioning if the need arises. However, field repairs can be performed. Refer to the repair parts list and note there the parts and the kits which are available.

