

Application

These valve actuators, with an 11 sq. in. (71 cm²) effective diaphragm area, are used with Invensys VB-7xxx series valves for proportional pneumatic control of hot water or chilled water valves.

The MK-46xx and MK4-46xx Series may also be mounted on discontinued 1/2" through 1-1/4" Barber-Colman/ Siebe/Invensys VB-111, VB-131, VB-314, and VB-9xxx series valves.

Features

- Rugged die cast aluminum housing
- Replaceable beaded molded neoprene diaphragm
- Built-in spring to retract output shaft on loss of air pressure
- Adjustable start point
- Multiple spring ranges for various applications
- 1/2" nominal stroke

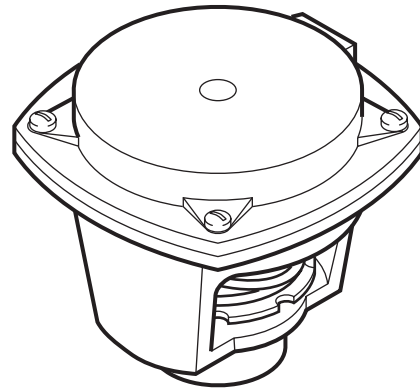

MK-46xx Series

Applicable Literature

- Invensys Building Systems Components Catalog, F-25683
- Invensys Building Systems Cross-Reference Guide, F-23638
- Invensys Building Systems Reference Manual, F-21683
- Invensys Building Systems Application Manual, F-21335
- AK-42309-500 Positive Positioner Pneumatic Relay General Instructions, F-22909
- AV-401 Linkage General Instructions, F-25586
- VB-7211 Valve Body General Instructions, F-24380
- VB-7212 Valve Body General Instructions, F-24381
- VB-7213 Valve Body General Instructions, F-26075
- VB-7214 Valve Body General Instructions, F-25675
- VB-7215 Valve Body General Instructions, F-26077
- VB-7221 Valve Body General Instructions, F-24384
- VB-7222 Valve Body General Instructions, F-24385
- VB-7223 Valve Body General Instructions, F-26073
- VB-7224 Valve Body General Instructions, F-24387
- VB-7225 Valve Body General Instructions, F-26079
- VB-7253 Valve Body General Instructions, F-24388
- VB-7263 Valve Body General Instructions, F-24389
- VB-7273 Valve Body General Instructions, F-24390
- VB-7283 Valve Body General Instructions, F-24391
- VB-7312 Valve Body General Instructions, F-24392
- VB-7313 Valve Body General Instructions, F-26074
- VB-7314 Valve Body General Instructions, F-24394
- VB-7315 Valve Body General Instructions, F-26078
- VB-7323 Valve Body General Instructions, F-26076
- VB-7332 Valve Body General Instructions, F-24396

SPECIFICATIONS

Construction:

Housing, Die cast aluminum.

Diaphragm, Replaceable beaded molded neoprene.

Stroke: (Table-1).

Effective Area: 11 sq. in. (71 cm²).

Spring: Retracts actuator shaft and raises valve stem on loss of air pressure.

Nominal Spring Range: (Table-1).

Start Point:

MK-4601, MK-4621: Adjustable +1/-2 psi (+7/-14 kPa).

MK-4611, MK-4641: ±2 psig (±14 kPa)

MK-4621-422: 10 psig (69 kPa)

Maximum Air Pressure: 30 psig (207 kPa).

Ambient Temperature Limits:

Shipping, -40 to 220 °F (-40 to 104 °C).

Operating, -20 to 220 °F (-29 to 104 °C).

Air Connections: 1/8 in. FNPT.

Valve Linkage: AV-401 (order separately).

Locations: NEMA Type 1 only.

Mounting: In any upright position with actuator head above horizontal center line of valve body.

Dimensions: 3-7/8" H x 4-3/4" W x 4-3/4" D in. (99 x 121 x 121 mm).

Table-1 Model Chart

Model Number	Nominal Spring Range		Nominal Stroke ^a in. (mm)	Valve Linkage	Valve Compatibility
	psig	kPa			
MK-4601 MK4-4601 ^b	3 to 8	21 to 55	1/2 (13)	AV-401	1/2" to 1-1/4" VB-7xxx 1/2" to 1-1/4" VB-9xxx ^c 1/2" to 1-1/4" VB-111 ^c 5/8" or 7/8" OD VB-131 ^c 1/2" to 1-1/4" VB-151 ^c
MK-4611 MK4-4611b	5 to 10	34 to 69			
MK-4621 MK4-4621b	8 to 13	55 to 90			
MK-4621-422 ^d	10 to 11.25	69 to 77			
MK-4641	3 to 13	21 to 90			

^a Nominal (no load) spring range based on 1/2" (13 mm) nominal stroke.

^b Includes factory AK-42309-500 installed positive positioner. Start point adjustable 1 to 12 psig (7 to 83 kPa). Span adjustable 2 to 13 psi (14 to 90 kPa).

^c Discontinued.

^d For sequencing applications, see VB-7332 General Instructions, F-24396.

ACCESSORIES

AK-42309-500 Positive positioner and linkage

TOOL-85 Manual hand pump bulb (included in TOOL-95-1)

TOOL-95-1 Pneumatic calibration tool kit

INSTALLATION

Inspection

Inspect the package for damage. If damaged, notify the appropriate carrier immediately. If undamaged, open the package and inspect the device for obvious damage. Return damaged products.

Requirements

- Piping diagrams.
- Tools (not provided): Appropriate wrenches for mounting bolts and adjustments.
- Appropriate valve body.
- Appropriate accessories.
- Training: Installer must be a qualified, experienced technician or fitter.



Caution:

- Make all connections in accordance with the piping diagram.
 - Avoid locations where excessive moisture, corrosive fumes, or vibration are present. NEMA Type 1 housings are intended for indoor use primarily to provide a degree of protection against contact with the enclosed equipment.
 - Install all two-way valves so that they close against the flow. An arrow on the valve body or tag indicates the proper flow direction.
 - Install three-way mixing valves with two inlets and one outlet.
 - The actuator can be mounted in any position above the horizontal centerline of the valve body. When selecting a location, allow sufficient room for accessories and for service of the product.
-

Mounting

The actuator may be shipped assembled to a valve body or as a separate component. These instructions are intended for use where the actuator is to be installed to a linkage and valve body, as a replacement unit, or when the actuator must be removed during valve installation.

The actuator is generally installed in an upright position and may be swivelled to any convenient position for connecting to the control air line. In addition the actuator can be removed from the valve with disturbing the spring setting.

NOTE

For complete mounting instructions, see AV-401 General Instructions, F-25586.

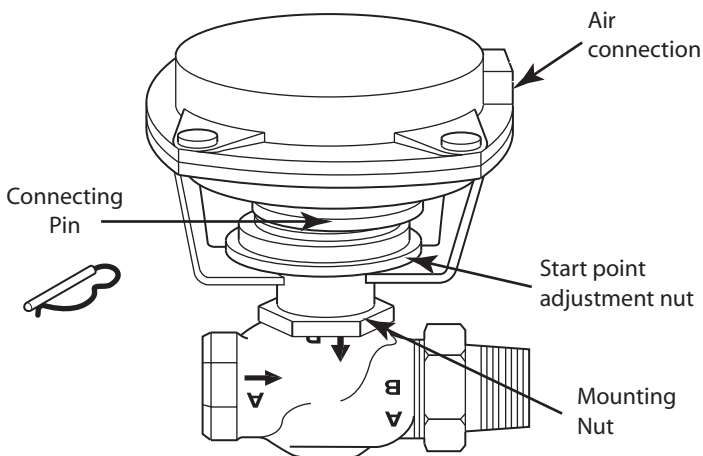

Figure-1 Typical Pneumatic Valve Assembly with MK-46xx Actuator

Removing Actuator from Valve Body (Figure-1)

1. Pull connecting pin to release valve stem from actuator piston.

NOTE

A slight amount of air pressure applied to the actuator may be necessary to relieve binding on the connecting pin. The TOOL-85 manual hand pump valve (included in TOOL-95-1) may be used for this purpose.

2. Disconnect air supply to the actuator.
3. Loosen mounting nut.
4. Lift actuator until it clears the valve.

Installing Actuator on Valve Body (Figure-1)

1. Position actuator on valve, with hole in piston shaft lining up with hole in valve stem extension.
2. Secure the actuator to the valve with mounting nut.
3. Insert pin to connect valve stem extension to piston

NOTE

It may be necessary to apply a slight amount of air pressure to the actuator in order to insert the pin. The TOOL-85 manual hand pump valve (included in TOOL-95-1) may be used for this purpose.

4. Loosen mounting nut and swivel actuator to convenient position for piping. Be sure to retighten the mounting nut.
5. Install air connection.

For additional information, refer to **AV-401 Linkage General Instructions, F-25586**.

ADJUSTMENTS

The start point adjustment (Figure-1) is the only actuator adjustment. The start point is the air pressure which, when applied to the actuator, causes the piston to begin to move downward under a no load condition.

In the course of meeting system requirements or replacing the diaphragm spring, the start point may have been changed. To adjust the start point, proceed as follows:

1. Apply desired start point air pressure to the actuator.
2. Rotate the start point adjustment nut until the desired start point is obtained.

To raise the start point, rotate the adjustment nut clockwise (CW) — when the actuator is viewed from below.

To lower the start point, rotate the adjustment nut counterclockwise (CCW)— when the actuator is viewed from below.

MAINTENANCE

Regular maintenance of the total system is recommended to assure sustained performance.

MAINTENANCE PARTS

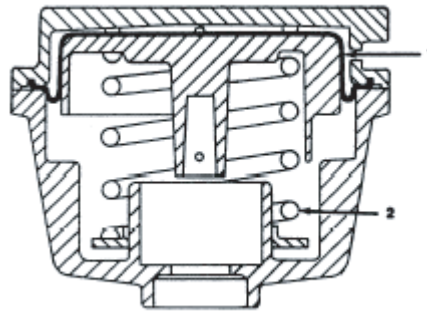

Figure-2 MK-46xx Maintenance Parts

Table-2 Maintenance Parts

Item No.	Part Number	Description	Actuator
1	PNV-002 ^a	Diaphragm	All
2	PNV-238	3-6 psig spring (brown)	MK-4601
	PNV-045-044	3-8 psig spring (black)	MK-4601
	PNV-045-044	5-10 psig spring (black)	MK-4611
	PNV-045-048	8-13 psig spring (light blue)	MK-4621
	PNV-239	10-13 psig spring (gray)	MK-4621
	PNV-050-043	3-13 psig spring (white)	MK-4641
	PNV-041-046	6-7 psig spring (red)	MK-4681 ^b
	PNV-232	10-11.25 psig spring (orange)	MK-4621-422

^a PNV-251 diaphragm available for high temperature applications. Order separately and field install.

^b Discontinued model.

FIELD REPAIR

Replacing Actuator Diaphragm



◆ **WARNING**

Strong spring forces approaching 100 lbs. (45 kg) are present. **Actuator must be connected to valve body and piston connected to the valve stem in order to replace the actuator diaphragm.**

1. Disconnect air line to actuator.
2. Remove the four cover mounting screws and the top cover.
3. Remove the old diaphragm and install the replacement along with the top cover.

NOTE

Be sure diaphragm is properly positioned in housing groove before securing cover.

4. Secure assembly with four screws, drawing screws down tightly, but evenly, all around.
5. Reconnect air line.

Replacing Actuator Spring



WARNING

Strong spring forces approaching 100 lbs. (45 kg) are present. Follow the following procedure in order to prevent injury when removing the top cover. **Actuator must be connected to valve body and piston connected to the valve stem in order to replace the spring.**

1. Disconnect air line to actuator.
2. Rotate start point adjustment counterclockwise (as viewed from the bottom) to remove as much spring compression as possible.
3. Remove the four cover mounting screws, the top cover, and the diaphragm.
4. While holding down the piston with the heel of your hand, remove the connecting pin.
5. Slowly release pressure on piston and remove piston.
6. Remove spring and insert replacement.
7. Position piston over spring, making sure position indicator is aligned with guide.
8. Pushing down on piston, align holes in valve stem extension and piston shaft and insert connecting pin.
9. Position diaphragm and top cover on actuator and even secure with the four screws.

NOTE

Be sure diaphragm is properly positioned in housing groove before securing cover.

10. Refer to "ADJUSTMENTS" on page 4 and adjust start point of actuator to desired value.

© Copyright 2004 Invensys Building Systems, Inc. All rights reserved.

No part of this document may be photocopied or reproduced by any means, or translated to another language without prior written consent of Invensys.

All specifications are nominal and may change as design improvements are introduced. Invensys shall not be liable for damages resulting from misapplication or misuse of its products.

Invensys is a trademark of Invensys plc and its subsidiaries and affiliates.