

## Application

The MA-5200 series and MA-5300 series actuators are used for electronic two-position control of valves and dampers which require a return to the normal position upon power interruption.

## Features

- Two-position actuators controlled by an SPST controller
- Spring return
- 24 Vac, 120 Vac, and 240 Vac models are available
- An actuator with the part number suffix "-500" has a built-in, adjustable, SPDT auxiliary switch
- Available in damper models or base models that require damper or valve linkage
- Die cast lower housing with 1/2" conduit opening and painted steel upper housing
- Hydraulic actuator with oil-immersed motor and pump

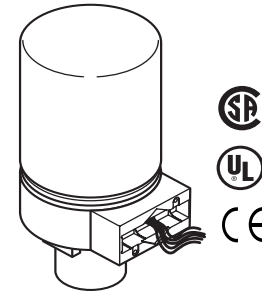

**MA-521X Series  
 Valve Actuator**

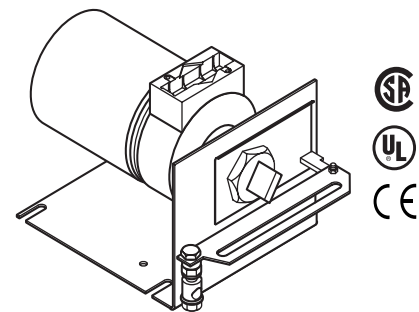

**MA-533X Series  
 Damper Actuator**

## Applicable Literature

- Environmental Controls First Edition Catalog, F-25683
- Environmental Controls Cross-Reference Guide F-23638
- Environmental Controls Reference Manual F-21683
- Environmental Controls Application Manual F-21335
- Engineering Bulletin EN-110, Damper Actuator Sizing, F-15260
- General Instructions Sheet F-19069, for Valve Linkages AV-600 and AV-601
- Material Safety Data Sheet MSDS-3 (Until Feb. 1989)
- Material Safety Data Sheet MSDS-12 (Currently)

# SPECIFICATIONS

## Actuator Inputs

**Control Circuit:** Two wire, SPST.

**Power Input:** Refer to Table-1 and Table-2.

**Connections:** Color-coded 4' (1.2 m) leads.

## Actuator Outputs

### Electrical:

**Auxiliary Switch (MA-5XXX-500)**, 10 Amps, 120/240 Vdc adjustable SPDT, factory set to close the N.O. contact at the retracted end of stroke.

### Mechanical:

#### Stroke,

**Damper** Approximately 2" (51 mm) from fully retracted to fully extended (includes AM-601 linkage).

**Valve** Approximately 9/16" (14.3 mm) from fully retracted to fully extended.

**Nominal Damper Area**, Actuator sizing should be done in accordance with damper manufacturer's specifications.

## Environment

### Ambient Temperature Limits:

**Shipping & Storage**, -40 to 140° F (-40 to 60° C).

### Operating,

**Damper** 0 to 140° F (-18 to 60° C).

**Valve** Refer to Table-3.

**Humidity:** 5 to 95% RH, non-condensing.

**Location:** NEMA Type 1.

## Agency Listings

**UL873**, Underwriters Laboratories (File #E9429 Category Temperature-Indicating and Regulating Equipment).

**CSA**, Certified for use in Canada by Underwriters laboratories, Canadian Standard C22.2 No. 24-93.

**European Community**, EMN Directive (89/336/EEC). Low Voltage Directive (72/23/EEC).

Table-1 Model Chart for Damper Actuators.

Part Number	Actuator Power Input				Timing in Seconds @ 72° F (22° C)		Torque Rating lb.-in. (N-m)	
	AC Voltage +10/ -15%	Hz		VA	Watts	To Extend (No Load Stroke)		Retract on Power Loss
MA-5330	120	50	60	18	14	60	15	20 (2.3)
MA-5333	24							

Table-2 Model Chart for Valve Actuators. Also for Damper Actuators with Field Assembled Damper Linkages.

Part Number	Actuator Power Input				10 Amps Aux Switch	Timing in Seconds @ 72° F (22° C)		Required Linkage <sup>a</sup>	
	AC Voltage +10/-15%	Hz		VA		Watts	To Extend (No Load Stroke)	Retract on Power Loss	Damper
MA-5210	120	50	60	18	14	60	15	AM-601 <sup>b</sup>	AV-600 AV-601 <sup>c</sup>
MA-5210-500									
MA-5211	240	50	60	18	14	60	15	AM-601 <sup>b</sup>	AV-600 AV-601 <sup>c</sup>
MA-5211-500									
MA-5213	24	50	60	18	14	60	15	AM-601 <sup>b</sup>	AV-600 AV-601 <sup>c</sup>
MA-5213-500									

<sup>a</sup> Damper models are provided with factory-installed damper linkages. Only base models require separately-ordered linkages.

<sup>b</sup> With the installation of the AM-601 damper linkage, these valve actuators become functionally the same as the damper actuators listed in Table-1. Refer to Table-1 for the torque rating.

<sup>c</sup> May be required for steam and hot water. Refer to Table-3.

Table-3 Restrictions on Maximum Ambient Temperature for Valve Actuators.

Maximum Temperature of Media in the Valve Body (Check Rating of the Valve) °F (°C)	Maximum Ambient Temperature of MA-521X Series	
	AV-600 (Only) °F (°C)	AV-600 and AV-601 °F (°C)
366 (186)	90 (32)	90 (32)
340 (171)	100 (38)	100 (38)
281 (138)	115 (46)	140 (46) <sup>a</sup>
181 (83)	140 (60) <sup>a</sup>	140 (60) <sup>a</sup>
80 (26)	140 (60) <sup>a</sup>	140 (60) <sup>a</sup>

<sup>a</sup> Maximum ambient temperature of the actuator must never exceed 140° F (60° C).

**ACCESSORIES**

**Common**

11-1612 1/2" conduit bushing

**Damper Linkages**

- AM-111 Crank arm for 5/16" diameter damper shaft
- AM-112 Crank arm for 3/8" diameter damper shaft
- AM-113 Crank arm for 1/2" diameter damper shaft
- AM-115 Crank arm for 7/16" diameter damper shaft
- AM-122 Linkage connector straight type
- AM-123 Damper clip
- AM-125 5/16" diameter x 20" damper rod
- AM-125-048 5/16" diameter x 48" damper rod
- AM-132 Ball joint connector
- AM-161-3 Damper linkage kit
- AM-601 Device includes mounting bracket, damper linkage with spring, and AM-122 straight connector. Required to modify (MA-521X series) valve actuators into 2" (51 mm) stroke damper actuators.
- AM-602 Spacer

**Valve Linkages**

- AV-600 Valve linkage
- AV-601 Valve linkage extension for hot water and steam applications; use with AV-600

**TOOLS (factory-available)**

- TOOL-12 Wrench for adjustment of auxiliary switch
- TOOL-19 Spring compression tool for AV-600
- TOOL-37 1-5/8" (41 mm) open-ended wrench

## TYPICAL APPLICATIONS (wiring diagrams)

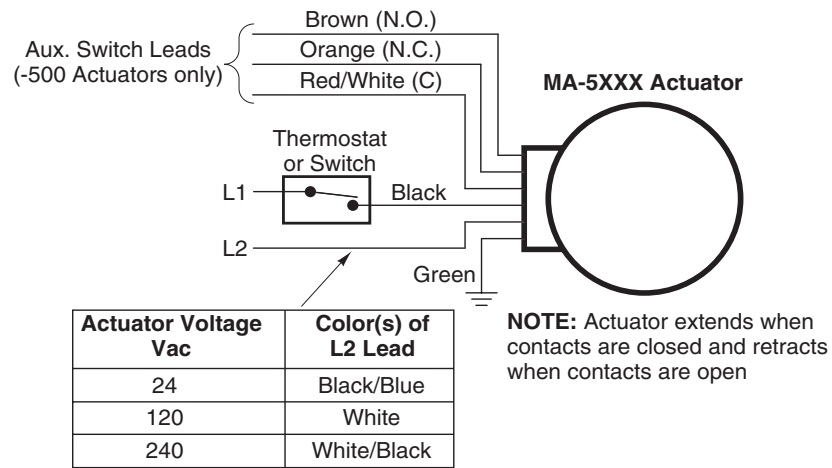

Figure-1 Typical Wiring for MA-5XXX Series Actuators.

## INSTALLATION

### Inspection

Inspect the package for damage. If damaged, notify the appropriate carrier immediately. If undamaged, open the package and inspect the device for obvious damage. Return damaged products.

### Requirements

- Job wiring diagrams
- Tools (not provided):
  - Digital Volt-ohm Meter (DVM)
  - Appropriate drill and drill bit for mounting screws
  - Appropriate screw drivers and wrenches
  - TOOL-12, Wrench for adjustment of auxiliary switch
  - TOOL-19, Spring compression tool for AV-600
  - TOOL-37, 1-5/8" open-ended wrench
- Training: Installer must be a qualified, experienced technician

---

#### Warning:

- Disconnect the power supply (line power) before installation to prevent equipment damage.
  - Make all connections in accordance with the wiring diagram and in accordance with national and local electrical codes. *Use copper conductors only.*
- 

#### Caution:

- Static charges produce voltages high enough to damage the electronic components. Follow static electricity precautions when installing or servicing the device(s). Discharge any static electricity you may have accumulated by using wrist straps, or by touching a known, securely grounded object.
  - Do not exceed the ratings of the device(s).
  - Do not apply power to the unit unless the damper linkage and/or the valve assembly have been installed.
  - Avoid locations where excessive moisture, corrosive fumes, or vibration is present.
  - Do not install insulation on any part of the actuator.
- 



## Mounting

---

**Caution:**

Do not twist or exert any force on the actuator housing during installation. Either turn the base by hand or, if necessary, use a 1-5/8" open-ended wrench (TOOL-37) on the flats provided on the actuator base or the valve body mounting nut. Refer to Figure-2.

---

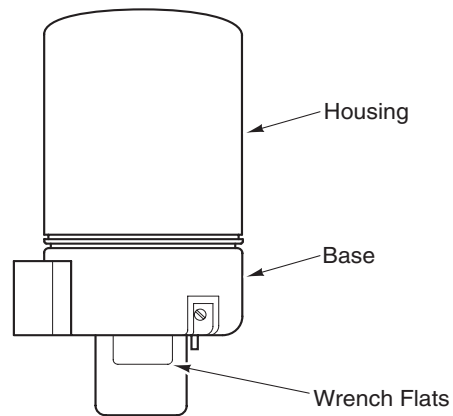

Figure-2 Housing and Base Location.

### Dampers

The actuator is not position sensitive. It can be mounted in any position in an NEMA Type 1 location.

### Valves

Allow 3" (76 mm) of clearance above the actuator valve assembly for the removal and reattachment of the actuator to the installed valve.

1. Install all two-way valves so that they close against the flow. An arrow on the valve body or tag indicates proper flow direction.
2. Always install three-way mixing valves with two inlets and one outlet.
3. Always install three-way diverting valves with one inlet and two outlets.

---

**Caution:**

For steam applications only, mount the actuator above the valve body at 45° from vertical.

---

4. Actuators can be mounted in any upright position above the centerline of the valve body.

## Wiring Requirements

### Power Leads

The low voltage (24 Vac) power leads may be connected to a Class 2 circuit if routed separately from Class 1 circuit wiring. The line voltage (120 and 240 Vac) leads must be connected to a Class 1 circuit. Refer to Figure-7.

Refer to Table-4 for the maximum length of run for the power leads, for the given wire size(s). To determine the allowable maximum power lead run when wiring multiple actuators, divide the maximum run shown in Table-4 by the number of actuators on the run. Refer to Figure-3 for further details.

Table-4 Power Wiring Data.

Actuator Voltage Vac	Actuator Model Number	Power Lead Colors	Wire Size GA	Maximum Wire Run ft. (m)
120	MA-5210	Black & White	14	3,500 (1,067)
	MA-5210-500			
240	MA-5211	Black & White/Black	14	6,000 (1,829)
	MA-5211-500			
24	MA-5213	Black & Black/Blue	14	300 (91.5)
	MA-5213-500		12	480 (146.3)
120	MA-5330	Black & White	14	3,500 (1,067)
	MA-5330-500			
24	MA-5333	Black & Black/Blue	14	300 (91.5)
	MA-5333-500		12	480 (146.3)

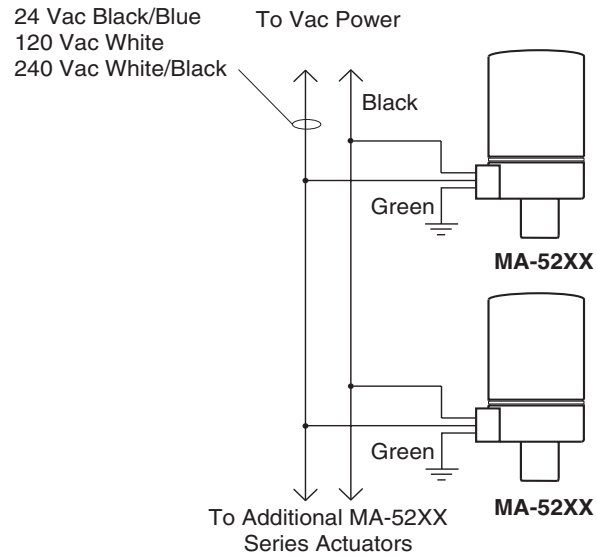

Figure-3 Wiring of Multiple MA-52XX Series Actuators to Single Power Source.

### Auxiliary Switch Leads

The low voltage (24 Vac) auxiliary switch leads may be connected to a Class 2 circuit.

The line voltage (120 Vac and 240 Vac) auxiliary switch leads must be connected to a Class 1 circuit and routed separately from any Class 2 circuit wiring. Refer to Figure-7.

## Wiring Connections

### Wire Lead Connections (No Conduit)

Make connections as required. Refer to Figure-1 for a wiring diagram of a typical application. Refer to Figure-4 for a view of the actuator.

---

*Note:* The cover plate and screw supplied with the actuator are not required with this method.

---

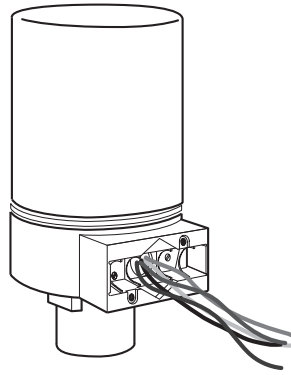

Figure-4 Connection of Wire Leads (No Conduit).

### Installing 3/8" Flexible Conduit Onto One Or Both Sides Of Actuator

Flexible conduit may be installed onto one or both sides of the actuator (refer to Figure-6 and Figure-7). Install each conduit as follows:

1. Determine the side of the actuator to which the flexible conduit is to be attached.
2. Remove the knockout (e.g., with channel lock pliers) on the selected side of the actuator. Refer to Figure-5.
3. Make the required connections. Refer to Figure-1 for a wiring diagram of a typical application.

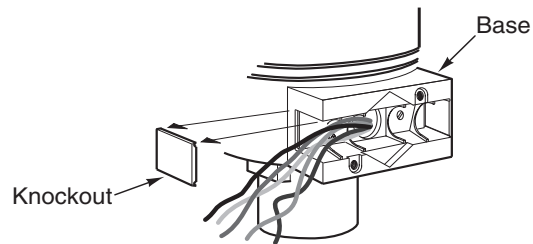

Figure-5 Removal of Knockout on Actuator Base.

4. Slip the conduit onto the base, over the ribs. Refer to Figure-6 and Figure-7.
5. If flexible conduit is to be installed on both sides of the actuator, repeat the preceding steps to install the second conduit.

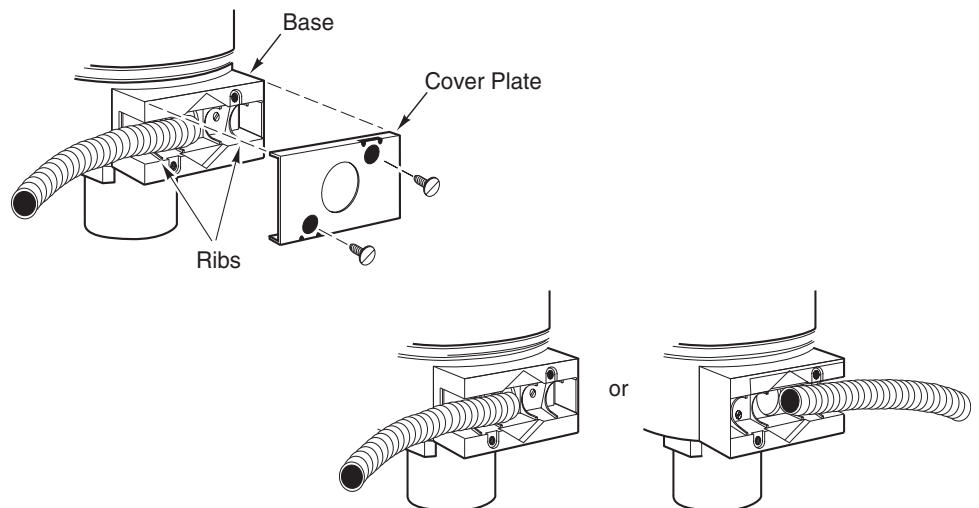

Figure-6 Flexible Conduit Installation to Either Side of Actuator.

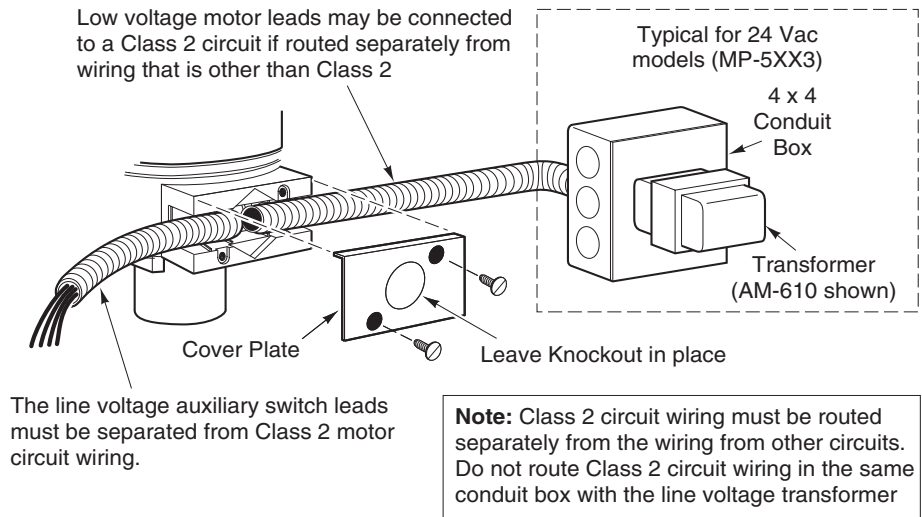

Figure-7 MA-5200 and MA-5300 Series Wiring with Separation for Class 2 and Line Voltage Circuits.

6. Install the cover plate with two screws. The cover plate and two screws are supplied with the actuator.

### Installing Conduit Box Onto Actuator

Installation of a conduit box allows for the attachment of one or more thin wall conduits to the actuator. This procedure also serves as an optional method for connecting flexible conduit to the actuator.

1. Remove the knockout from the cover plate supplied with the actuator. Refer to Figure-8.

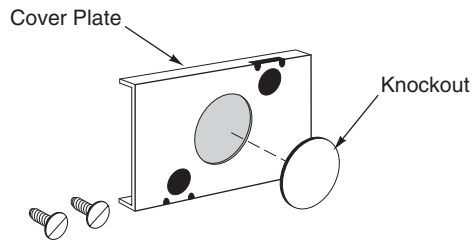

Figure-8 Cover Plate Knockout Removal.

2. Slip the leads through a standard 1/2" conduit bushing (Figure-9, not supplied) and the knockout hole in the cover plate. Refer to Figure-10.

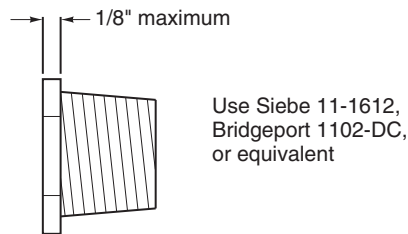

Figure-9 1/2" Conduit Bushing.



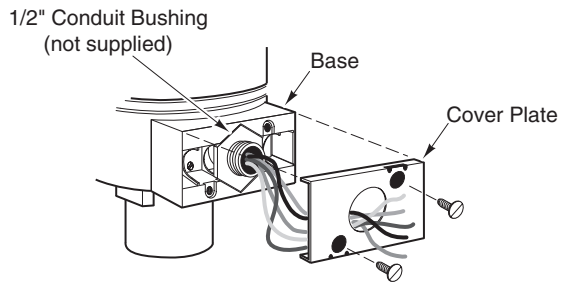

Figure-10 Conduit Bushing and Cover Plate Installation.

3. Seat the conduit bushing in the base.
4. Install the cover plate, using the two screws provided.
5. Loosely install the conduit box and the locknut onto the conduit bushing. Refer to Figure-11.

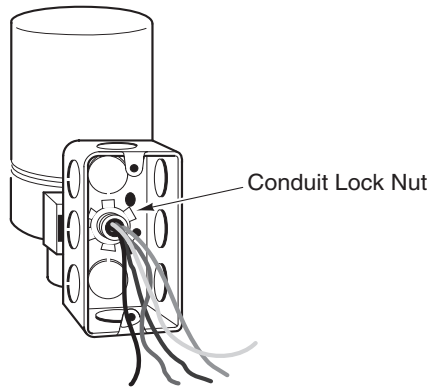

Figure-11 Attachment of Conduit Box to Threaded Adaptor.

6. Tighten the locknut as follows:
  - a. Tilt the conduit box approximately 30 degrees counterclockwise, relative to the actuator.
  - b. Finger-tighten the locknut against the conduit box.
  - c. Rotate the conduit box clockwise until it is aligned with the actuator. This will tighten the locknut.
7. Make the required wiring connections. Refer to Figure-1 for a wiring diagram of a typical application.
8. Install the conduit to the conduit box as required.

---

*Note:* As shown in Figure-10, the hole in the cover plate of the actuator conduit housing is sized to accept both British standard M20 (20 mm) conduit connectors and 20 mm-to-PG16 adaptors for use with DIN PG16 connectors. (Follow the steps for installing the conduit box to the actuator.)

---

# Linkage Assembly

## Damper

*Note:* Each actuator in the MA-5X3X series is provided with a factory-installed damper linkage. No separately-ordered linkage is required.

### **Caution:**

Do not twist or exert any force on the actuator housing during installation. Either turn the base by hand or, if necessary, use a 1-5/8" (41 mm) open-ended wrench (TOOL-37) on the flats provided on the actuator base, or on the valve body mounting nut. (Refer to Figure-2.)

1. Determine the best mounting position for the actuator as follows:
  - a. Determine, from the system requirements, if the damper should spring-return to the open position (refer to Figure-12) or closed position (refer to Figure-13) whenever power is lost to the actuator. For example, an outside air damper actuator is typically linked so as to retract (spring-return) to the damper's fully closed position (safe position).

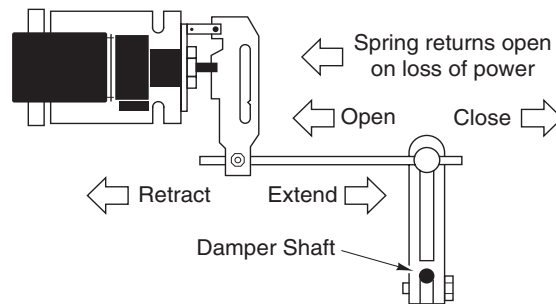

Figure-12 Dampers Open When Actuator Retracts (Spring>Returns Open on Power Loss).

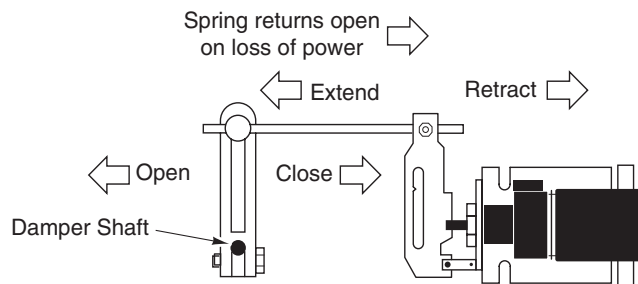

Figure-13 Dampers Open When Actuator Extends (Spring>Returns Closed on Power Loss).

- b. Be sure to allow adequate working space around the actuator mounting location to mount the actuator, link it to the damper, and wire it into the system (refer to Figure-20).
- c. If possible, select a mounting position such that, at mid-stroke, the actuator crank arm and the damper crank arm on the drive shaft are each at a 90° angle to the damper rod (Refer to Figure-14). This is the recommended mounting position. It may be necessary to swivel the actuator linkage to arrive at this mounting location.

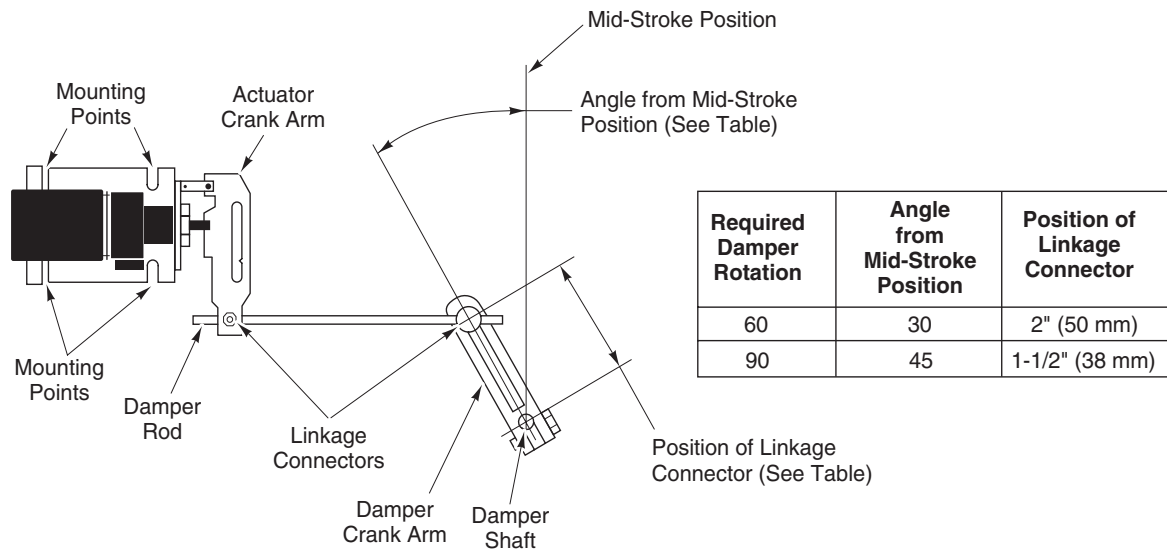

Figure-14 Recommended Actuator/Damper Mounting.

- d. Consider the damper rod length when positioning the actuator in relation to the damper. A damper rod that is too long is not rigid enough to provide good control, while a damper rod that is too short makes adjustment difficult.
2. Position the actuator on the duct and mark the location of the mounting holes, using the actuator mounting bracket as a template (refer to Figure-20).
3. Drill or punch the mounting holes in the duct for the appropriate 1/4" (6 mm) diameter screws or bolts. The actuator must be mounted firmly enough to prevent excessive actuator movement under normal damper loading. If there is excessive actuator movement, the damper may not fully open or close.
4. Mount a ball joint connector in the slot on the damper crank arm. To achieve 90° of damper rotation, position the connector 1-1/2" (38 mm) from the centerline of the shaft hole on the crank arm. For 60° of damper rotation, position the connector 2" (50 mm) from the shaft hole centerline. Typically, 60° to 70° of rotation (maximum is 90°) is sufficient to permit almost maximum air flow through the dampers. (Refer to Figure-14).
5. Rotate the damper to its open position. Install and secure the damper crank arm (with ball joint connector) to the damper shaft, positioning the crank arm as follows (Refer to Figure-14):
  - a. To achieve 60° of damper rotation, position the crank arm so that it is pointed towards the actuator at 30° from its mid-stroke position.
  - b. To achieve 90° of damper rotation, position the crank arm so that it is pointed towards the actuator at 45° from its mid-stroke position.
6. Install the damper rod by sliding one end through the ball joint connector mounted on the damper crank arm, and the other end through the straight connector on the actuator crank arm. Tighten the nut on the actuator crank arm's straight connector. Cut off any excess length of damper rod.
7. For normally open dampers, tighten the nut on the ball joint connector on the damper crank arm. To ensure that the damper closes completely, make adjustments so that the actuator is 1/16" (1.6 mm) from the extended end of stroke when the damper closes. Verify and, if necessary, make final adjustments during system checkout.
8. For normally closed dampers, rotate the damper crank arm until the damper is closed. While holding the damper closed, tighten the nut on the ball joint connector on the damper crank arm. To ensure that the damper closes completely, make adjustments so that the actuator is 1/16" (1.6 mm) from the retracted end of stroke when the damper closes.

Final adjustment of the actuator and damper must be performed when the system is powered and functioning. Refer to the CHECKOUT section to ensure that the damper is linked correctly.

## Valve

For valve assembly details refer to **AV-600, Valve Linkage Kit General Instructions, F-26279** or **AV-601 Linkage Extension Kit General Instructions, F-26280**. Refer to Figure-21 for external dimensions of the valve actuator.

## Adjustments

### Auxiliary Switch (MA-5XXX-500)

The switching point is adjustable over the entire actuator stroke and is pre-set at the factory to close the N.C. contacts at the retracted end of stroke. Turning the switch adjustment screw CW (using TOOL-12), adjusts the make (or break) point closer to the extended end of stroke. (Refer to Figure-15).

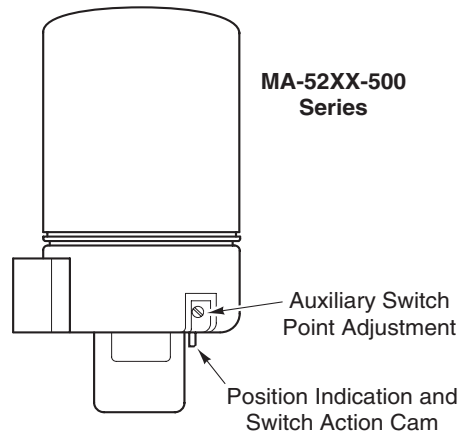

Figure-15 Auxiliary Switch Actuation Point Adjustment and Position Indication for MA-5XXX-500 Series.

## CHECKOUT

After the entire system has been installed and the actuator has been powered up, perform the following checks for proper system operation.

---

**Caution:** Never power the actuator without a spring return linkage attached.

---

### Positioning with Controller

If the sensed media is within the controller's setpoint range, the actuator can be positioned by adjusting the controller setpoint up and down. Check for correct operation of the actuator (valve or damper) while the actuator is being stroked.

### Go, No-Go Test

1. Apply power to the actuator. The actuator motor should run and the actuator shaft should extend.
2. Remove power from the actuator. The actuator motor should stop running and the actuator shaft should spring-return to the retracted position.

## THEORY OF OPERATION

Refer to Figure-16. The permanently sealed, oil-filled case contains a movable hydraulic piston assembly and an electric pump for the hydraulic system. The pump generates a fluid pressure which is transmitted to the top of the piston, creating a hydraulic force which drives the piston downward. Opposing the hydraulic force is the spring of the valve or damper linkage. When the hydraulic force becomes great enough to overcome the opposing spring force, the piston translates downward, extending the output shaft. The electric pump is powered by the input supply voltage and runs whenever the voltage is applied. When power is removed from the pump, it stops running, decreasing the hydraulic force above the piston. This allows the spring force to overcome the hydraulic force, pushing the piston upward and retracting the output shaft. The oil above the piston is allowed to flow backward through the pump by means of a check valve.

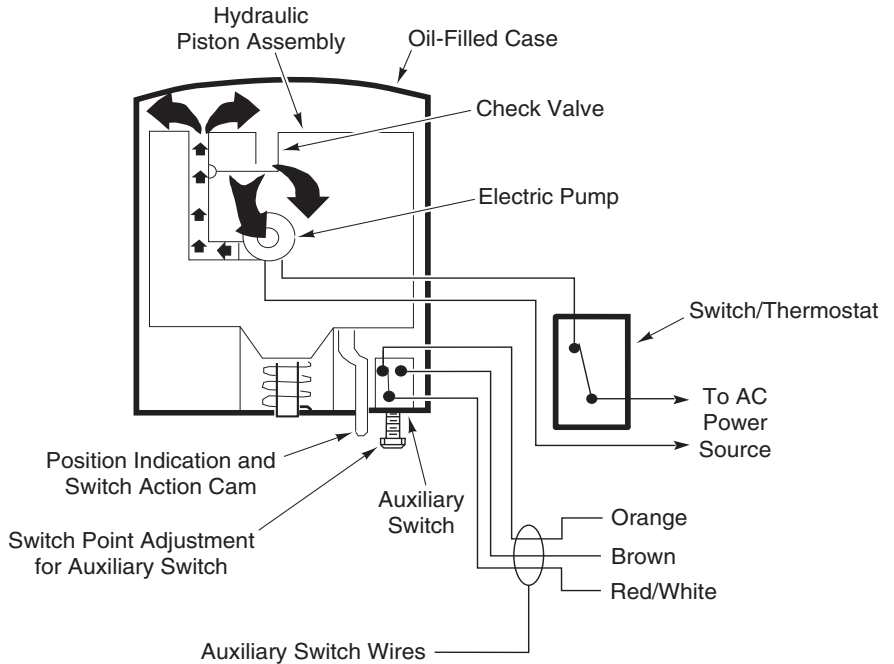

Figure-16 MA-5XXX Series Actuators.

## REPLACEMENT PARTS

The installation of replacement actuators, in place of the obsolete series of MA-5XXX actuators (refer to Figure-17), may require additional items. These replacement items are required for the following reasons:

1. The AM-601 damper linkage is used to convert base actuators to damper actuators when damper models are not available.
2. The AM-602 spacer is used when current actuators are installed on old linkages (refer to Figure-18 and Figure-19).
3. The AE-249 transformer (208 Vac to 120 Vac) is used when replacing 208 Vac actuators (MA-5XX2) with 120 Vac actuators (MA-5XX0).

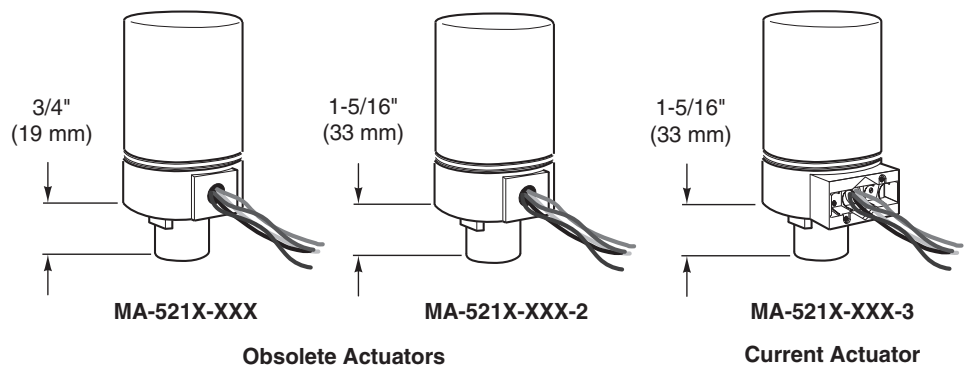

Figure-17 Current and Obsolete Actuators.

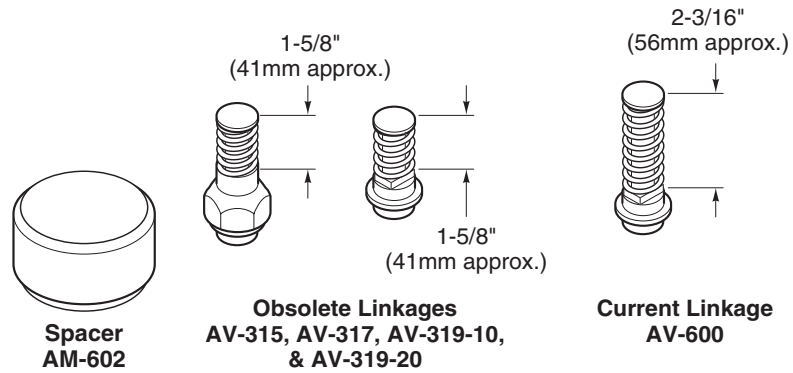

Figure-18 Current and Obsolete Valve Linkages.

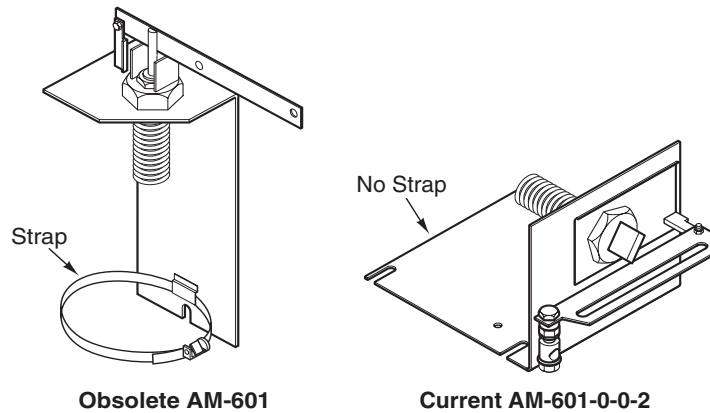

Figure-19 Current and Obsolete Damper Linkages.

## MAINTENANCE

The actuator is sealed in oil and requires no maintenance.

Regular maintenance of the total system is recommended to assure sustained, optimum performance.

## TROUBLESHOOTING

Use the following steps to locate malfunctions:

1. Check the actuator by applying the proper supply voltage.
2. The motor should run when power is applied. If it does not run, the actuator is inoperative and should be replaced.
3. While the motor is running, the actuator should extend. If it does not extend, check the mechanical linkage for any damage or misadjustment which could prevent the actuator from extending. If the mechanical linkage is inoperative, adjust the linkage or replace the damaged components, as applicable. If the mechanical linkage moves correctly and freely, the problem lies in the actuator and it must be replaced.
4. If applying power directly to the actuator results in correct operation of the actuator, the actuator and linkage are functional, and the problem lies in the wiring or thermostat. Repair or replace the wiring or thermostat, as applicable.

## FIELD REPAIR

None. Replace an inoperative actuator with a functional unit.

## DIMENSIONAL DATA

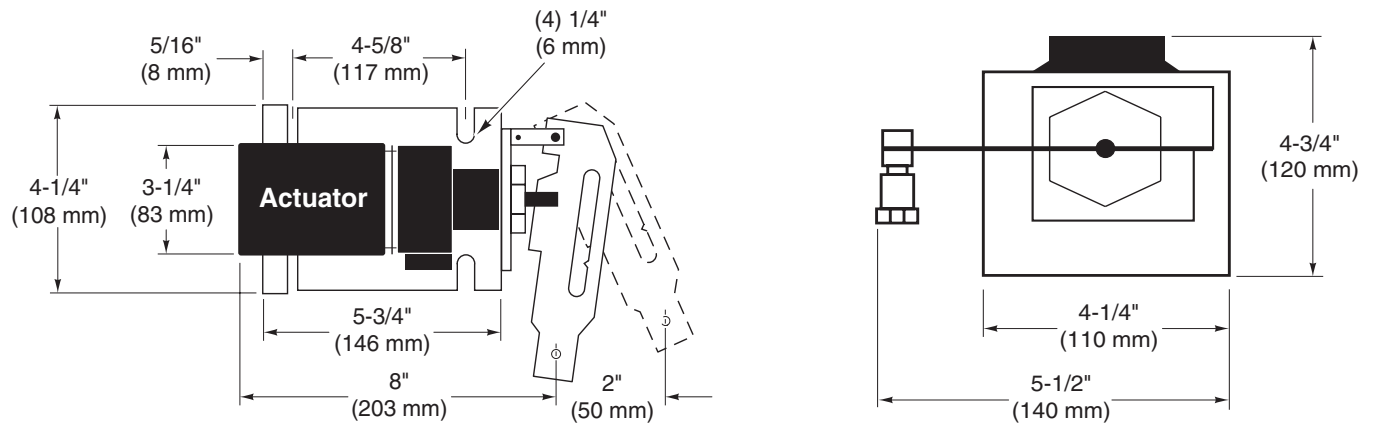

Figure-20 Damper Linkage Assembly Dimensions.

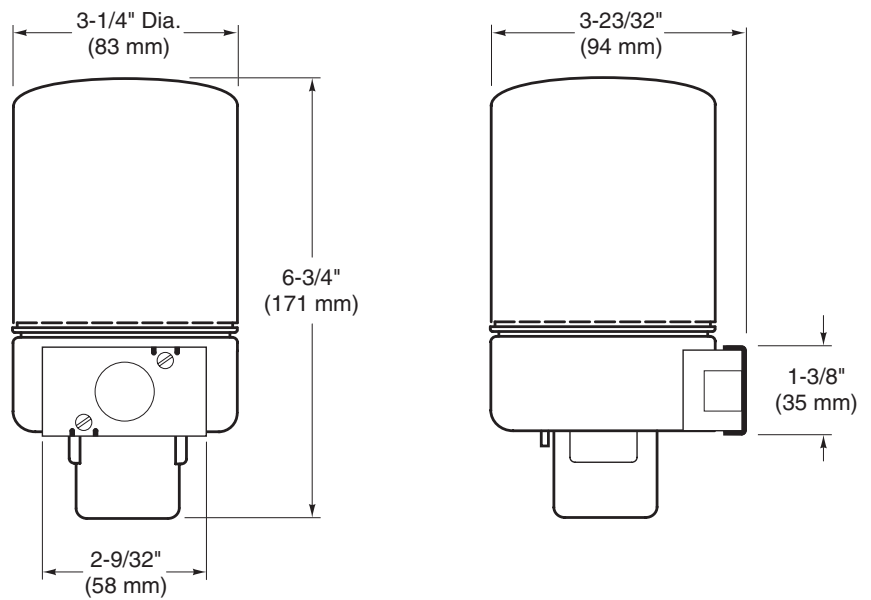

Figure-21 Actuator Dimensions.

**invensys**®

**Invensys Building Systems, Inc.**  
1354 Clifford Avenue  
P.O. Box 2940  
Loves Park, IL 61132-2940  
[www.invensysibs.com](http://www.invensysibs.com)

Invensys and DuraDrive are trademarks of Invensys plc and its subsidiaries and affiliates.

Specifications may change as design improvements are introduced.