

Application

The MP series actuators are used for two-position, floating, and proportional control of dampers, valves, and program switches in heating, ventilating, air conditioning, and similar applications.

Features

- Proportional actuators with built-in feedback potentiometers
- Spring return and non-spring return models available
- 24 Vac, 120 Vac, and 240 Vac models are available
- Die cast housings with four 1/2" conduit openings
- Oil-immersed motor and gear train

Applicable Literature

- Siebe Environmental Controls Valve Selection Guide, F-26094
- Siebe Environmental Controls Cross-Reference Guide, F-23638
- Siebe Environmental Controls Reference Manual, F-21683
- Siebe Environmental Controls Application Manual, F-21335
- Siebe Environmental Controls First Edition Catalog, F-25683
- Material Safety Data Sheet MSDS-4
- AM-363 Gasket Cover Kit General Instructions, F-25598
- CP-8301 Solid State Actuator Drive General Instructions, F-14940
- CP-8391-716 Electronic Actuator Drive General Instructions, F-21220
- CP-8391-910 Series 4 to 20 mA Electronic Actuator Drive General Instructions, F-22453
- AE-504 Solid State Paralleling Relay General Instructions, F-16524

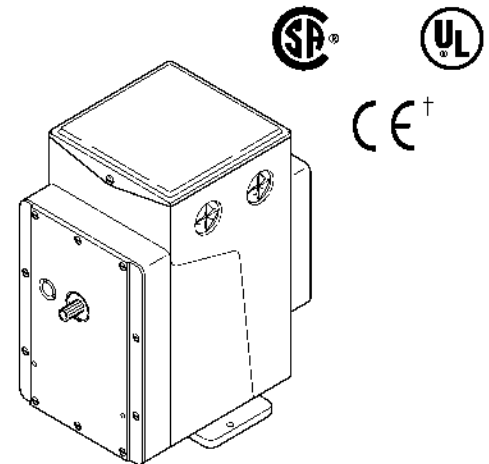

Typical Spring Return

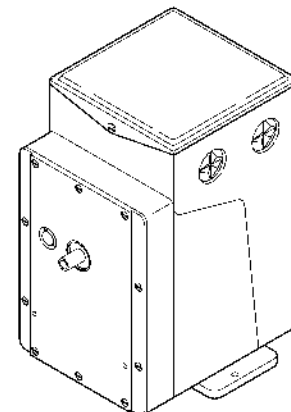

Typical Non-Spring Return

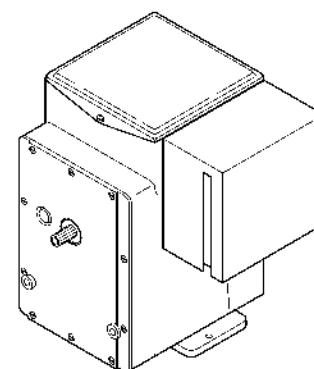

Typical -6XX Suffix
(CP-8301-XXX or CP-8391-91X Installed)

† Refer to Table-2 and Table-3 to identify specific models that are in compliance with CE requirements.

SPECIFICATIONS

Actuator Inputs

Input Control Signals: Refer to the actuator selection tables beginning on page 3 for input control signal capability versus specific actuator models.

Floating, Requires one Single Pole Double Throw (SPDT) switch with floating (center off) position rated at 0.9 amps @ 24 Vac or two Single Pole Single Throw (SPST) switches rated at 0.9 amps @ 24 Vac.

Two-Position,

SPDT Requires snap acting switch rated at 0.9 amps @ 24 Vac.

SPST Can be used with certain spring return actuators. Switch must be rated to handle actuator power requirements.

Microtherm[®], Proportional Electrical system with the following typical controllers: PP-22X series, TP-1XX series, TP-2XX series, TP-3XX series, TP-4XX series, TP-1XXX series, and TP-1XXXX series.

Standard Control of a single actuator.

Sequencing Control of two actuators in sequence.

Five-Position Used typically for adjustable minimum position (five positions) of an economizer actuator.

Slidewire and Paralleling, Requires AE-504 paralleling relay. Refer to **AE-504 Solid State Paralleling Relay General Instructions F-16524**. AE-504 accepts 100 Ω to 1000 Ω slidewires.

Voltage Vdc, Requires CP-8301-XXX series of solid state actuator drives. Refer to **CP-8301 Solid State Actuator Drive General Instructions F-14940**. Refer to the actuator selection tables beginning on page 3.

Current mAdc, Requires CP-8391-XXX series of solid state actuator drives. Refer to the actuator selection tables beginning on page 3.

Power Requirements: Refer to the actuator selection tables beginning on page 3 to determine power requirements.

Connections:

MP-3XX, 4XX, 2XXX, 4XXX, Coded screw terminals.

Models with "-600" Suffix, Coded screw terminals except for input signal which are color coded pigtailed.

Actuator Outputs

Torque: Refer to the actuator selection tables beginning on page 3 to determine the actuator torque rating.

Nominal Damper Area: Actuator selection should be made in accordance with the damper manufacturer's specifications.

Stroke (Degrees of Rotation), Refer to the actuator selection tables beginning on page 3 for information on degrees of rotation.

Auxiliary Switch, Refer to the actuator selection tables beginning on page 3 for the models that include an auxiliary switch. Refer to Table-6 for ratings.

Spring Return: Refer to the actuator selection tables beginning on page 3 for models that are spring return.

Environment

Ambient Temperature Limits:

Shipping and Storage, -40 to 160° F (-40 to 71° C).

Operating, -40 to 136° F (-40 to 58° C).

Humidity: 5 to 95% RH, non-condensing.

Locations: NEMA 1

NEMA 4 for non-spring return actuators with AM-363.

Agency Listings:

UL 873, Underwriters Laboratories (File #E9429 Category Temperature Indicating and Regulating Equipment).

CSA, Canadian Standards Association (File #LR3728).

European Community, EMC Directives (89/336/EEC and 92/31/EEC). Low Voltage Directive (72/23/EEC). Refer to Table-2 and Table-3 to identify specific models that are in compliance with CE requirements.

Actuators in the actuator selection tables below with "-600" suffix have the CP-8301-120 factory installed. All CP-8301s have a fixed span of 3 Vdc to drive the actuator full stroke and a start point adjustable from 2 to 12 Vdc (factory set 6 Vdc).

The CP-8391-91X series have a fixed range of 4 to 20 mAdc to drive the actuator full stroke. Refer to **CP-8391-910 Series 4 to 20 mA Electronic Actuator Drive General Instructions F-22453**. The CP-8391-716 has an adjustable span of 4 to 16 mAdc (factory set for 16) and adjustable start point of 2 to 16 mAdc (factory set for 4). The input signal on CP-8391-716 is optically isolated. Refer to **CP-8391-716 Electronic Actuator Drive General Instructions F-21220**.

Table-1 MP-2XXX Series Model Chart.

| Actuator Part Number | Internal Wiring (See Figure) | Input Control Signal External Wiring (and required Interface Module that must be purchased separately) (See Figure) | | | | Power Requirements | | | | Output Shaft | | | | Built-in Transformer ^b | | | |
|----------------------|------------------------------|--|-----------------------------|---|-----------------------------|--------------------|-------------------------|--|-----|--------------|----------------------|--------------------------|---------------------|-----------------------------------|---------------|-------------|--------------------------------|
| | | 2-Position SPST Spring Return | 2-Position or Floating SPDT | Microtherm ^a (Proportional Electric) | | Voltage Vdc | Current mAdc | Volts | Hz. | Amps | Torque Lb.-in. (N-m) | Timing Seconds (No Load) | Degrees of Rotation | | Spring Return | Aux. Switch | |
| | | | | Standard | Sequencing of Two Actuators | | | | | | | | | | | | 5-Position (Adj. Min Position) |
| MP-213-500 | Figure-27 | - | Figure-5 | Figure-7 | - | Figure-14 (AE-504) | Figure-17 (CP-8301-024) | Figure-19 (CP-8391-913) | 24 | 60 | 2.2 | 50 (5.6) | 25 | 180 (nonAdj.) | No | SPDT | - |
| MP-2150-500 | Figure-29 | - | Figure-6 | - | - | Figure-15 (AE-504) | Figure-18 (CP-8301-120) | Figure-21 ^c or Figure-23 ^d | 120 | 60 | 0.5 | 50 (5.6) | 25 | 180 (non-Adj.) | No | SPDT | Yes |

Table-2 MP-3XX Series Model Chart.

| Actuator Part Number | Internal Wiring (See Figure) | Input Control Signal External Wiring (and required Interface Module that must be purchased separately) (See Figure) | | | | Power Requirements | | | | Output Shaft | | | | Built-in Transformer ^b | | | |
|-----------------------|------------------------------|--|-----------------------------|---|-----------------------------|--------------------|-------------------------|-------------------------|-----|--------------|----------------------|--------------------------|---------------------|-----------------------------------|---------------|-------------|--------------------------------|
| | | 2-Position SPST Spring Return | 2-Position or Floating SPDT | Microtherm ^a (Proportional Electric) | | Voltage Vdc | Current mAdc | Volts | Hz. | Amps | Torque Lb.-in. (N-m) | Timing Seconds (No Load) | Degrees of Rotation | | Spring Return | Aux. Switch | |
| | | | | Standard | Sequencing of Two Actuators | | | | | | | | | | | | 5-Position (Adj. Min Position) |
| MP-361 ^e | Figure-24 | Figure-3 | Figure-5 | Figure-7 | - | Figure-14 (AE-504) | Figure-17 (CP-8301-024) | Figure-19 (CP-8391-913) | 24 | 60 | 2.5 | 50 (5.6) | 90 | 180 (Adj.) | CW | SPDT | - |
| MP-367 ^e | Figure-32 | - | - | - | Figure-11 | - | - | - | 24 | 60 | 2.5 | 50 (5.6) | 90 | 180 (Adj.) | CW | SPST | - |
| MP-371 ^{e,g} | Figure-24 | Figure-3 | Figure-5 | Figure-7 | - | Figure-14 (AE-504) | Figure-17 (CP-8301-024) | Figure-19 (CP-8391-913) | 24 | 60 | 2.5 | 50 (5.6) | 90 | 180 (nonAdj.) | CCW | SPDT | - |
| MP-377 ^e | Figure-32 | - | - | - | Figure-11 | - | - | - | 24 | 60 | 2.5 | 50 (5.6) | 90 | 180 (nonAdj.) | CCW | SPST | - |
| MP-379 ^e | Figure-30 | - | - | - | Figure-12 | - | - | - | 24 | 60 | 2.5 | 50 (5.6) | 90 | 180 (nonAdj.) | CCW | None | - |
| MP-381 ^e | Figure-24 | - | Figure-5 | - | - | Figure-14 (AE-504) | Figure-17 (CP-8301-024) | Figure-19 (CP-8391-913) | 24 | 60 | 2.2 | 220 (24.9) | 130 | 180 (Adj.) | No | SPDT | - |
| MP-382 ^e | Figure-24 | - | Figure-5 | - | - | Figure-14 (AE-504) | Figure-17 (CP-8301-024) | Figure-19 (CP-8391-913) | 24 | 60 | 2.2 | 220 (24.9) | 130 to 1300 (Adj.) | 180 (Adj.) | No | SPDT | - |
| MP-387 ^e | Figure-32 | - | - | - | Figure-11 | - | - | - | 24 | 60 | 2.2 | 220 (24.9) | 130 | 180 (Adj.) | No | SPST | - |
| MP-388 ^e | Figure-30 | - | - | - | Figure-12 | - | - | - | 24 | 60 | 2.2 | 220 (24.9) | 130 | 180 (Adj.) | No | None | - |

^a Typical Microtherm Controllers: PP-22X Series; TP-1XX Series; TP-4XX Series; TP-101X Series; TP-103X Series; and TP-1XXXX Series.

^b Units with a "-2" suffix, e.g. MP-XXXX-XXX-2-X, include a built-in transformer (used for Microtherm or with AE-504) with secondary leads wired externally to terminals 7 and 8 of the actuator. Red (24 Vac) to terminal 8 and Blue (12 Vac) to terminal 7. When these actuators are used with controllers other than Microtherm or AE-504, disconnect the Red and Blue leads and tape off. Note: Models prior to "-2" suffix had transformer wired directly to potentiometer. To disconnect the transformer, remove the back plate of the actuator, disconnect and tape the transformer leads.

^c Requires CP-8391-910.

^d Requires CP-8391-716.

^e Units with a "-0-0-2" suffix are in compliance with CE requirements.

^f Rotation adjustable 45 to 320°. Caution: On actuators with proportional input signals changing the rotation will affect the control, since the internal feedback potentiometer's travel is fixed.

^g MP-371 models with the "-621" suffix are obsolete.

4 Table-3 MP-4XX Series Model Chart.

| Actuator Part Number | Internal Wiring (See Figure) | Input Control Signal External Wiring (and required Interface Module that must be purchased separately) (See Figure) | | | | Power Requirements | | | | Output Shaft | | | | Aux. Switch | Built-in Transformer ^b | |
|---------------------------|------------------------------|---|-----------------------------|---|-----------------------------|-------------------------|--|-------|-----|--------------|----------------------|--------------------------|---------------------|-------------|-----------------------------------|---------------|
| | | 2-Position SPST Spring Return | 2-Position or Floating SPDT | Microtherm ^a (Proportional Electric) | | Voltage Vdc | Current mA/dc | Volts | Hz. | Amps | Torque Lb.-in. (N-m) | Timing Seconds (No Load) | Degrees of Rotation | | | Spring Return |
| | | | | Standard | Sequencing of Two Actuators | | | | | | | | | | | |
| MP-421 | Figure-25 | - | Figure-6 | - | - | Figure-16 (CP-8301-120) | Figure-20 ^c or Figure-22 ^d | 120 | 60 | 0.65 | 60 (6.8) | 25 | 180 (Adj.) | No | SPDT | - |
| MP-422 | Figure-25 | - | Figure-6 | - | - | Figure-16 (CP-8301-120) | Figure-20 ^c or Figure-22 ^d | 120 | 60 | 0.65 | 60 (6.8) | 25 to 250 (Adj.) | 180 (Adj.) | No | SPDT | - |
| MP-423 | Figure-25 | - | Figure-6 | - | - | Figure-16 (CP-8301-120) | Figure-20 ^c or Figure-22 ^d | 120 | 60 | 0.65 | 60 (6.8) | 13 | 90 (Adj.) | No | SPDT | - |
| MP-424 | Figure-25 | - | Figure-6 | - | - | Figure-16 (CP-8301-120) | Figure-20 ^c or Figure-22 ^d | 120 | 60 | 0.65 | 60 (6.8) | 13 to 130 (Adj.) | 90 (Adj.) | No | SPDT | - |
| MP-451 | Figure-25 | - | Figure-6 | - | - | Figure-16 (CP-8301-120) | Figure-20 ^c or Figure-22 ^d | 120 | 60 | 0.65 | 220 (24.9) | 90 | 180 (Adj.) | No | SPDT | - |
| MP-452 | Figure-25 | - | Figure-6 | - | - | Figure-16 (CP-8301-120) | Figure-20 ^c or Figure-22 ^d | 120 | 60 | 0.65 | 220 (24.9) | 80 to 800 (Adj.) | 180 (Adj.) | No | SPDT | - |
| MP-453 | Figure-25 | - | Figure-6 | - | - | Figure-16 (CP-8301-120) | Figure-20 ^c or Figure-22 ^d | 120 | 60 | 0.65 | 220 (24.9) | 40 | 90 (Adj.) | No | SPDT | - |
| MP-454 | Figure-25 | - | Figure-6 | - | - | Figure-16 (CP-8301-120) | Figure-20 ^c or Figure-22 ^d | 120 | 60 | 0.65 | 220 (24.9) | 40 to 400 (Adj.) | 90 (Adj.) | No | SPDT | - |
| MP-461-600 ^e | Figure-25 | - | 1.5 | - | - | Figure-16 ^h | - | 120 | 60 | 0.5 | 50 (5.6) | 90 | 180 (Adj.) | CW | SPDT | - |
| MP-465 | Figure-26 | Figure-4 | Figure-6 | Figure-9 | - | Figure-18 (CP-8301-120) | Figure-21 ^e or Figure-23 ^d | 120 | 60 | 0.5 | 50 (5.6) | 90 | 180 (Adj.) | CW | SPDT | Yes |
| MP-470 | Figure-31 | - | - | - | Figure-13 | Figure-16 ^h | - | 120 | 60 | 0.5 | 50 (5.6) | 90 | 180 (non-Adj.) | CCW | None | Yes |
| MP-471-600 ^{e,g} | Figure-25 | - | - | - | - | Figure-15 (AE-504) | - | 120 | 60 | 0.5 | 50 (5.6) | 90 | 180 (non-Adj.) | CCW | SPDT | - |
| MP-475 | Figure-26 | Figure-4 | Figure-6 | Figure-9 | - | Figure-18 (CP-8301-120) | Figure-21 ^e or Figure-23 ^d | 120 | 60 | 0.5 | 50 (5.6) | 90 | 180 (non-Adj.) | CCW | SPDT | Yes |
| MP-480 | Figure-31 | - | - | - | Figure-13 | Figure-16 ^h | - | 120 | 60 | 0.5 | 220 (24.9) | 130 | 180 (Adj.) | No | None | Yes |
| MP-481-600 ^e | Figure-25 | - | - | - | - | Figure-15 (AE-504) | - | 120 | 60 | 0.5 | 220 (24.9) | 130 | 180 (Adj.) | No | SPDT | - |
| MP-483 | Figure-26 | - | Figure-6 | - | - | Figure-18 (CP-8301-120) | Figure-21 ^e or Figure-23 ^d | 120 | 60 | 0.5 | 220 (24.9) | 65 | 90 (Adj.) | No | SPDT | Yes |
| MP-485 | Figure-26 | - | Figure-6 | - | - | Figure-18 (CP-8301-120) | Figure-21 ^e or Figure-23 ^d | 120 | 60 | 0.5 | 220 (24.9) | 130 | 180 (Adj.) | No | SPDT | Yes |
| MP-486 | Figure-26 | - | Figure-6 | - | - | Figure-18 (CP-8301-120) | Figure-21 ^e or Figure-23 ^d | 120 | 60 | 0.5 | 220 (24.9) | 130 to 1300 (Adj.) | 180 (Adj.) | No | SPDT | Yes |
| MP-495 ⁱ | Figure-26 | - | Figure-6 | - | - | Figure-15 (AE-504) | Figure-21 ^e or Figure-23 ^d | 120 | 60 | 0.95 | 450 (50.9) | 130 | 180 (Adj.) | No | SPDT | Yes |

Footnotes for this table are listed on the following page.

Table-4 MP-4XXX Series Model Chart.

| Actuator Part Number | Internal Wiring (See Figure) | Input Control Signal External Wiring (and required Interface Module that must be purchased separately) (See Figure) | | | | | Power Requirements | | | Output Shaft | | | | Built-in Transformer ^b | Aux. Switch | | |
|----------------------|------------------------------|---|-----------------------------|---|--------------------------------|-------------------------|-------------------------|--|-------|--------------|------|----------------------|--------------------------|-----------------------------------|-------------|---------------------|---------------|
| | | 2-Position SPST Spring Return | 2-Position or Floating SPDT | Microtherm ^a (Proportional Electric) | | 135 to 1,000 Ω Sidewire | Voltage Vdc | Current mAdc | Volts | Hz. | Amps | Torque Lb.-in. (N-m) | Timing Seconds (No Load) | | | Degrees of Rotation | Spring Return |
| | | | | Standard | 5-Position (Adj. Min Position) | | | | | | | | | | | | |
| MP5-4651 | Figure-26 | Figure-4 | Figure-6 | - | - | Figure-15 (AE-504) | Figure-18 (CP-8301-240) | Figure-21 ^c or Figure-23 ^d | 240 | 50 | 0.25 | 50 (5.6) | 108 | 180 (Adj. ^f) | CW | SPDT | Yes |
| MP-4701 | Figure-31 | - | - | - | Figure-13 | - | - | - | 240 | 60 | 0.25 | 50 (5.6) | 90 | 180 (non-Adj.) | CCW | None | Yes |
| MP5-4751 | Figure-26 | Figure-4 | Figure-6 | - | - | Figure-15 (AE-504) | Figure-18 (CP-8301-240) | Figure-21 ^c or Figure-23 ^d | 240 | 50 | 0.25 | 50 (5.6) | 108 | 180 (non-Adj.) | CCW | SPDT | Yes |
| MP-4851 | Figure-26 | - | Figure-6 | - | - | Figure-15 (AE-504) | Figure-18 (CP-8301-240) | Figure-21 ^c or Figure-23 ^d | 240 | 60 | 0.25 | 220 (24.9) | 130 | 180 (Adj. ^f) | No | SPDT | Yes |
| MP5-4851 | Figure-26 | - | Figure-6 | - | - | Figure-15 (AE-504) | Figure-18 (CP-8301-240) | Figure-21 ^c or Figure-23 ^d | 240 | 50 | 0.25 | 220 (24.9) | 156 | 180 (Adj. ^f) | No | SPDT | Yes |

^a Typical Microtherm Controllers: PP-22X Series; TP-1XX Series; TP-4XX Series; TP-101X Series; TP-103X Series; and TP-1XXXX Series.

^b Units with a "-2" suffix, e.g. MP-XXXX-XXX-2-X, include a built-in transformer (used for Microtherm or with AE-504) with secondary leads wired externally to terminals 7 and 8 of the actuator. Red (24 Vac) to terminal 8 and Blue (12 Vac) to terminal 7. When these actuators are used with controllers other than Microtherm or AE-504, disconnect the Red and Blue leads and tape off. Note: Models prior to "-2" suffix had transformer wired directly to potentiometer. To disconnect the transformer, remove the back plate of the actuator, disconnect and tape the transformer leads.

^c Requires CP-8391-910.

^d Requires CP-8391-716.

^e Units with a "-0-0-2" suffix are in compliance with CE requirements.

^f Rotation adjustable 45 to 320°. Caution: On actuators with proportional input signals changing the rotation will affect the control, since the internal feedback potentiometer's travel is fixed.

^g MP-371 models with the "-621" suffix are obsolete.

^h Integral solid state drive accepts 2-15 Vdc voltage.

ⁱ MP-495 is not rated for UL or CSA

Table-5 Part Numbers for Hazardous Locations Applications.

| Hazardous Locations ^a | Hz | Listings |
|---|-------|-----------------------------|
| MP6-361 MP6-371 MP6-381 MP6-465 MP6-475 MP6-485 | 60 Hz | UL Listed and CSA Certified |
| MP7-361 MP7-371 MP7-381 MP7-4651 MP7-4751 MP7-4851 | 50 Hz | UL Listed and CSA Certified |

^a Class 1, Groups C and D, and Class 2, Groups E, F, and G Hazardous Locations; Ref. EN-56-2.

Table-6 Auxiliary Switch Ratings.

| Switch Electrical Rating | 120 Vac | 240 Vac |
|--------------------------|-----------|-----------|
| Running | 5.8 amps | 2.9 amps |
| Locked Rotor | 34.8 amps | 17.4 amps |
| Non-Inductive | 12 | 6 |

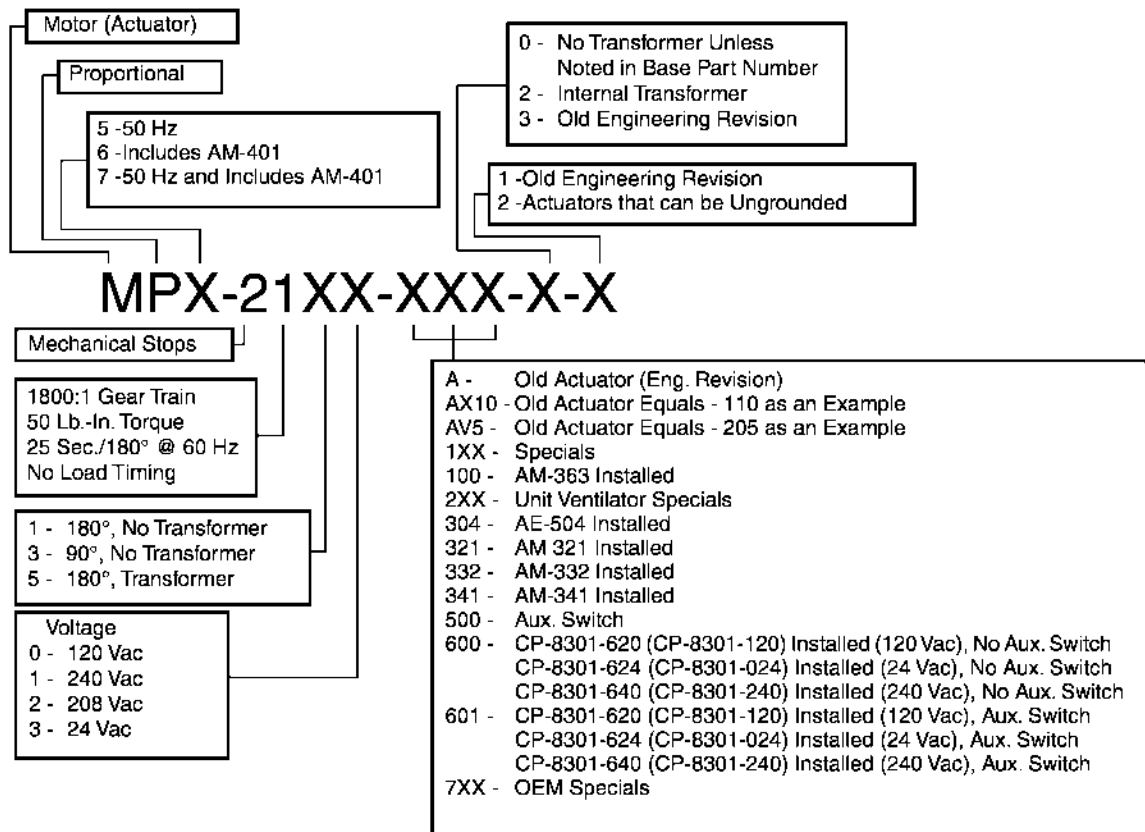

Figure-1 Part Number System for MP-2XXX-XXX-X-X Series Actuators.

Note: This figure is for information only. Do not use it for ordering or selecting product.

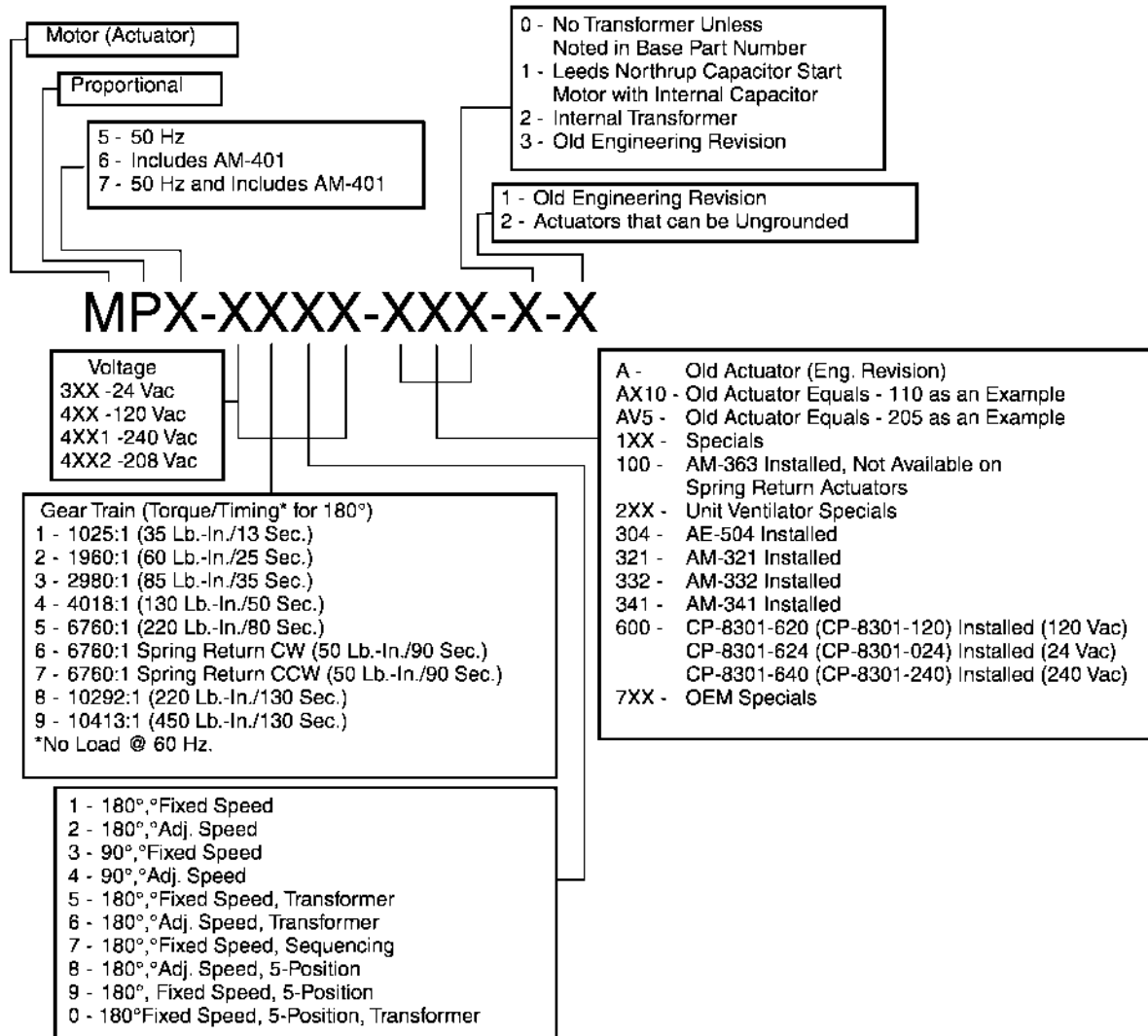

Figure-2 Part Number System for MP-3XX, MP-4XX, or MP-4XXX Series Actuators.

Note: This figure is for information only. Do not use it for ordering or selecting product.

ACCESSORIES

Damper linkage accessories

| | |
|------------|--|
| AM-111 | Crank arm for 5/16" (7.9 mm) diameter damper shaft |
| AM-112 | Crank arm for 3/8" (9.5 mm) diameter damper shaft |
| AM-113 | Crank arm for actuator or 1/2" (12.7 mm) diameter damper shaft |
| AM-115 | Crank arm for 7/16" (11.1 mm) diameter damper shaft |
| AM-116 | Splined crank arm for actuator |
| AM-122 | Linkage connector, straight type |
| AM-123 | Damper clip |
| AM-125 | 5/16" x 20" (7.9 mm x 0.5 m) damper rod |
| AM-125-048 | 5/16" x 48" (7.9 mm x 1.2 m) damper rod |
| AM-132 | Ball joint connector |
| AM-161 | Damper linkage kit |
| AM-161-1 | Damper linkage kit |
| AM-301 | 90 degree mounting bracket |

Miscellaneous actuator accessories

| | |
|----------|---|
| AM-321 | Two step switch kit |
| AM-332 | Potentiometer kit |
| AM-341 | Four step switch kit |
| AM-342 | Two step switch and potentiometer kit |
| AM-363 | NEMA 4 gasket kit for non-spring return actuators only |
| AM-401 | Hazardous location housing for non-spring return units except suffix "-600" |
| AM-402 | Hazardous location housing for spring return units except suffix "-600" |
| TOOL-201 | Calibration kit for System 8000™ |
| TOOL-209 | 135 Ω slidewire calibration kit |

Valve linkage for 50 lb.-in. minimum, 180° actuator

| | |
|--------|---|
| AV-329 | Valve linkage for 2-1/2" and 3" VB-9323 |
| AV-391 | Valve linkage for 15 to 50 mm and 1/2" to 2" VB-72XX or VB-73XX (also valve linkage for obsolete 1/2" to 1-1/4" VB-92XX or VB-93XX) |
| AV-392 | Valve linkage for obsolete 1-1/2" and 2" VB-92XX or VB-93XX |
| AV-395 | Valve linkage for 65 and 80 mm VB-9215 or VB-9315, and 2-1/2" to 4" VB-9213 or VB-9313 |

Valve linkage for 130 lb.-in. minimum, 180° actuator

| | |
|--------|---|
| AV-330 | Valve linkage for 2-1/2" and 3" VB-9323 |
| AV-352 | Valve linkage for 2-1/2" to 6" VB-921X or VB-931X, 4" to 6" VB-9323 |
| AV-393 | Valve linkage for 15 to 50 mm and 1/2" to 2" VB-72XX or VB-73XX (also valve linkage for obsolete 1/2" to 1-1/4" VB-92XX or VB-93XX) |
| AV-394 | Valve linkage for obsolete 1-1/2" and 2" VB-92XX or VB-93XX |
| AV-396 | Valve linkage for 65 and 80 mm VB-9215 or VB-9315, and 2-1/2" to 4" VB-921X or VB-931X |

TYPICAL APPLICATIONS (wiring diagrams)

List of Figures

| | | |
|-----------|---|---------|
| Figure-3 | External Wiring for SPST Control of MP-361 and MP-371, 24 Vac Actuators. | page 11 |
| Figure-4 | External Wiring for SPST Control of MP-465, MP-475, MP5-4651, and MP5-4751 Line Voltage Actuators. | page 11 |
| Figure-5 | External Wiring for SPDT (Snap Acting or Floating) Switch for Control of 24 Vac Actuators MP-361, MP-371, MP-381, MP-382 and MP-2113-500. | page 12 |
| Figure-6 | External Wiring for SPDT (Snap Acting or Floating) Switch for Control of Line Voltage Actuators. | page 12 |
| Figure-7 | Microtherm Controller with 24 Vac Actuators – Standard Wiring Diagram. | Page 13 |
| Figure-8 | Microtherm Controller with 24 Vac Actuators – Reversed (Cooling) Wiring Diagram. | page 13 |
| Figure-9 | External Wiring of Microtherm Controller with Line Voltage Actuator – Standard Wiring. | page 14 |
| Figure-10 | External Wiring of Microtherm Controller with Line Voltage Actuator – Reversed (Cooling) Wiring. | page 14 |
| Figure-11 | External Wiring for Microtherm Controller with 24 Vac Sequencing Actuators. | page 15 |
| Figure-12 | External Wiring for Microtherm Controller with Five-Position 24 Vac Actuators. | page 16 |
| Figure-13 | External Wiring for Microtherm Controller with Five-Position Line Voltage Actuator. | page 17 |
| Figure-14 | External Wiring for Slidewire Controller with 24 Vac Actuators. | page 18 |
| Figure-15 | External Wiring for Slidewire Controller with Line Voltage Actuator. | page 18 |
| Figure-16 | External Wiring for CP-8301-120, Vdc Interface with Line Voltage Actuators without Internal Transformer. | page 19 |
| Figure-17 | External Wiring for CP-8301-024, Vdc Interface with 24 Vac Actuators. | page 20 |
| Figure-18 | External Wiring for CP-8301-120 and CP-8301-240, Vdc Interface with Line Voltage Actuators with Internal Transformer. | page 21 |
| Figure-19 | External Wiring for CP-8391-913, 4 to 20 mAdc Interface with 24 Vac Actuators. | page 22 |
| Figure-20 | External Wiring for CP-8391-910, 4 to 20 mAdc Interface with Line Voltage Actuators without Internal Transformer. | page 22 |
| Figure-21 | External Wiring for CP-8391-910 and CP-8391-911, 4 to 20 mAdc Interface with Line Voltage Actuators with Internal Transformer. | page 23 |
| Figure-22 | External Wiring for CP-8391-716, mAdc Interface with Line Voltage Actuators without Internal Transformer. | page 23 |
| Figure-23 | External Wiring for CP-8391-716, mAdc Interface with Line Voltage Actuators with Internal Transformer. | page 24 |
| Figure-24 | Internal Wiring for 24 Vac Actuator. | page 24 |
| Figure-25 | Internal Wiring for Line Voltage Actuators. | page 25 |
| Figure-26 | Internal Wiring for Line Voltage Actuator with Built-in Transformer. | page 25 |
| Figure-27 | Internal Wiring for 24 Vac Actuator without Limit Switches (Actuator is Stall Type with Built-in Mechanical Stops). | page 26 |
| Figure-28 | Internal Wiring for Line Voltage Actuators without Limit Switches (Actuator is Stall Type with Built-in Mechanical Stops.) | page 26 |
| Figure-29 | Internal Wiring for Line Voltage Actuators without Limit Switches and Built-in Transformer (Actuator is Stall Type with Built-in Mechanical Stops). | page 27 |
| Figure-30 | Internal Wiring for 24 Vac Five-Position Actuators. | page 27 |
| Figure-31 | Internal Wiring for Line Voltage Five-Position Actuators. | page 28 |
| Figure-32 | Internal Wiring for 24 Vac Sequencing Actuators. | page 28 |

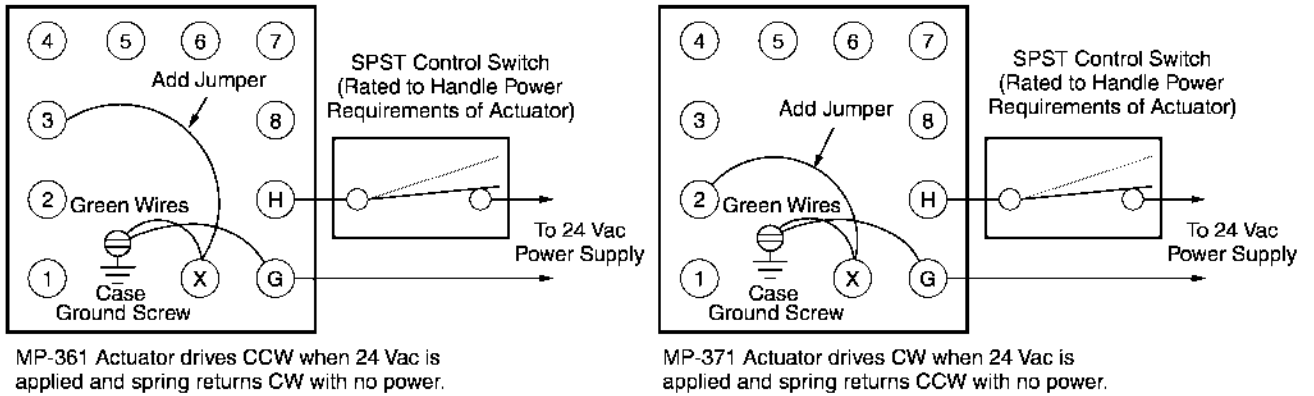

Figure-3 External Wiring for SPST Control of MP-361 and MP-371, 24 Vac Actuators.

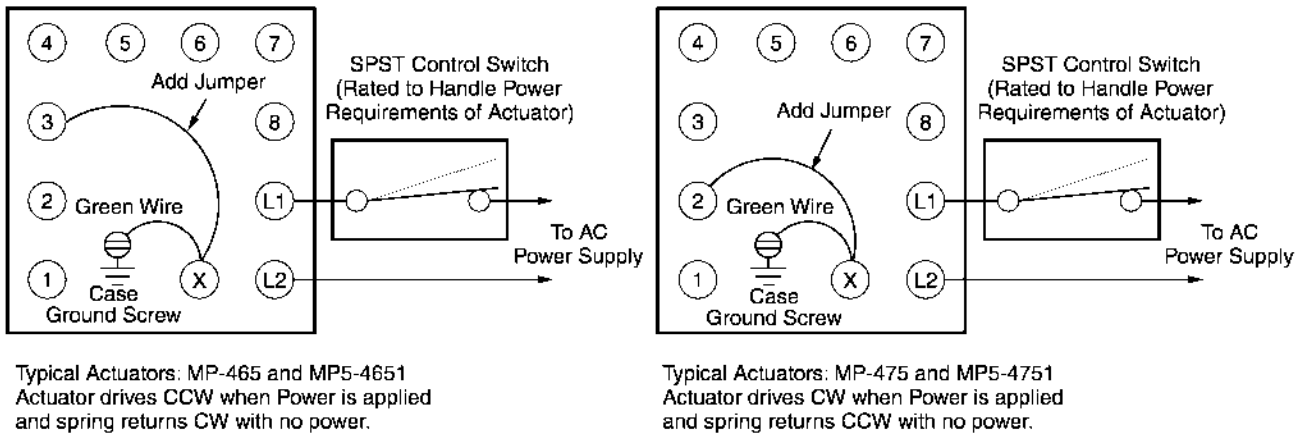

Figure-4 External Wiring for SPST Control of MP-465, MP-475, MP5-4651, and MP5-4751 Line Voltage Actuators.

Typical Actuators: MP-361, MP-371, MP-381, MP-382, and MP-2113-500.

Note: Each pole of a switch or a relay can control only one actuator.

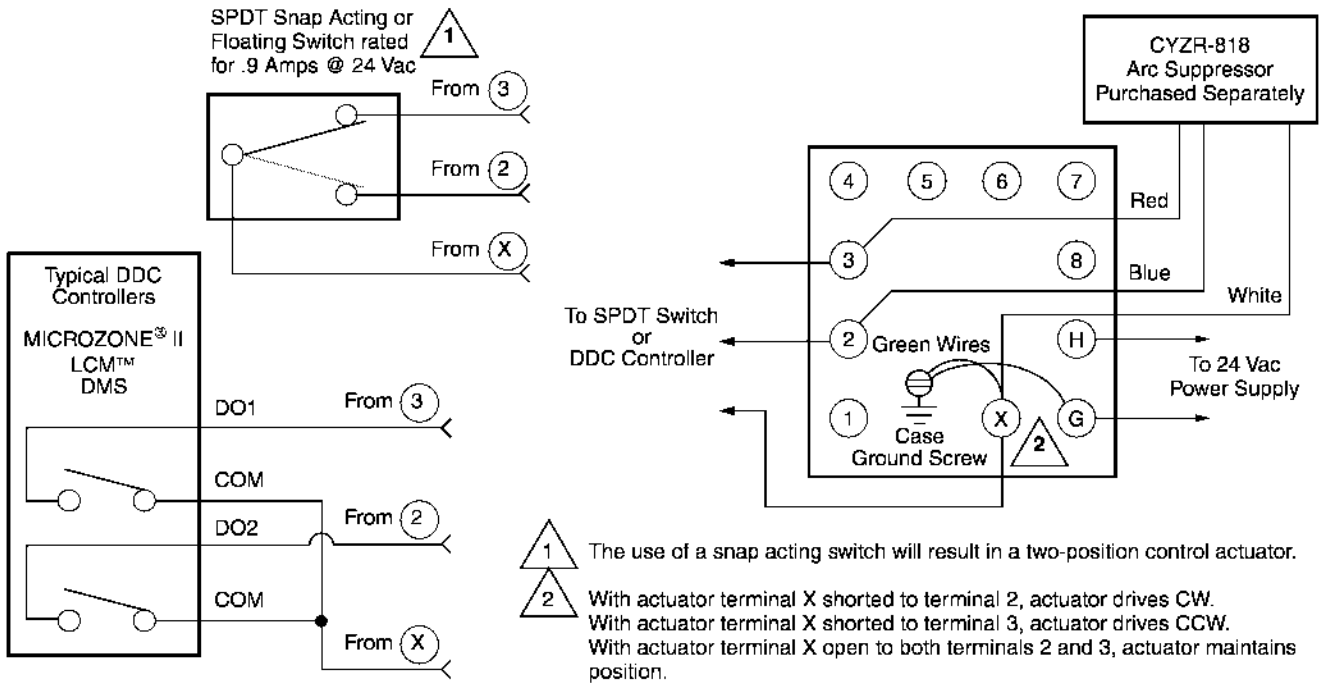

Figure-5 External Wiring for SPDT (Snap Acting or Floating) Switch for Control of 24 Vac Actuators MP-361, MP-371, MP-381, MP-382, and MP-2113-500.

Typical Actuators: MP-421, MP-422, MP-423, MP-424, MP-451, MP-452, MP-4553, MP-454, MP-465, MP-483, MP-485, MP-486, MP-495, MP-2130-500, MP-2150-500, MP5-2151-500, MP5-4651, MP5-4751, MP-4851, and MP5-4851.

Note: Each pole of a switch or a relay can control only one actuator.

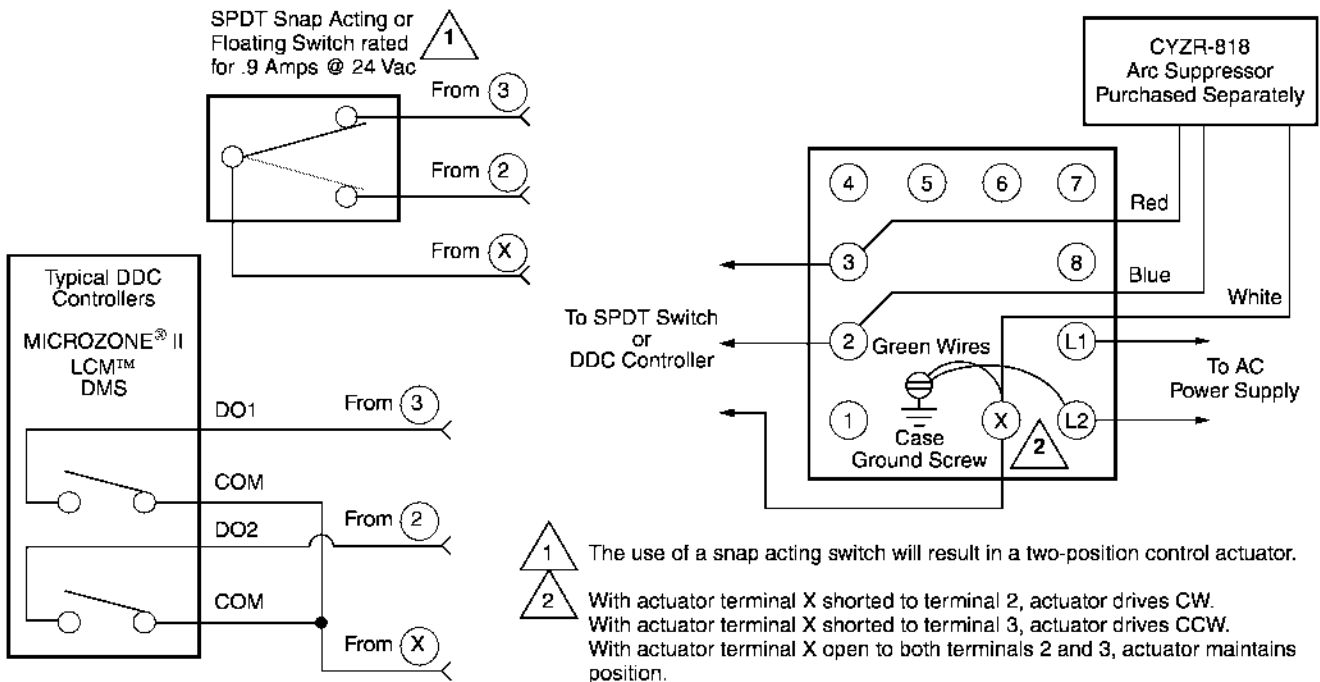

Figure-6 External Wiring for SPDT (Snap Acting or Floating) Switch for Control of Line Voltage Actuators.

Typical Actuators: MP-361, MP-371, MP-381, MP-382, and MP-2113-500.

Typical Microtherm Controllers: PP-22X Series, TP-2XX Series, TP-3XX Series, TP-4XX Series, and TP-101X Series.

C =Common of Switch to R and B.

1 =Feedback from actuator (24 Vac with actuator full Counterclockwise rotation (CCW) to 12 Vac at Clockwise rotation (CW) end).

R =Closes on temperature (pressure) drop and drives the actuator CCW (opens valve).

B =Closes on temperature (pressure) rise and drives the actuator CW (closes valve).

Typical Cooling Microtherm: TP-1031.

C =Common of switch to R and B.

1 =Feedback from Actuator (24 Vac with actuator full CCW to 12 Vac at CW end).

R =Closes on temperature rise and drives the actuator CCW (opens valve).

B =Closes on temperature drop and drives the actuator CW (closes valve).

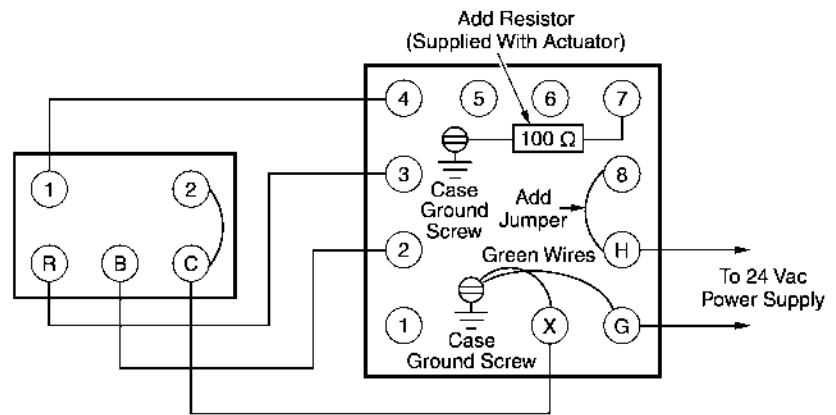

Figure-7 Microtherm Controller with 24 Vac Actuators – Standard Wiring Diagram.

Typical Microtherm Controllers: PP-22X Series, TP-2XX Series, TP-3XX Series, TP-4XX Series, and TP-101X Series.

C =Common of Switch to R and B.

1 =Feedback from Actuator (12 Vac with Actuator full CCW to 24 Vac at CW end).

R =Closes on temperature (pressure) drop and drives the actuator CW (closes valve).

B =Closes on temperature (pressure) rise and drives the actuator CCW (opens valve).

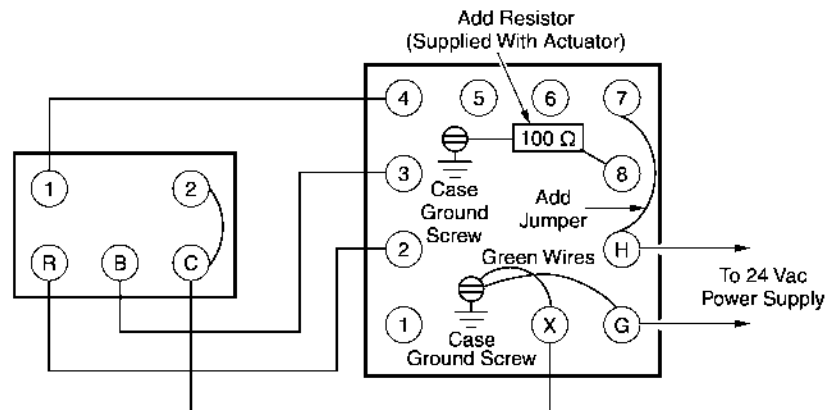

Figure-8 Microtherm Controller with 24 Vac Actuators – Reversed (Cooling) Wiring Diagram.

Typical Actuators: MP-465, MP-475, MP-485, MP-486, MP-495, MP-2130-500, MP-2150-500, MP5-2151-500, MP5-4651, MP5-4751, MP-4851, and MP5-4851.

Typical Microtherm Controllers: PP-22X Series, TP-2XX Series, TP-3XX Series, TP-4XX Series, and TP-101X Series.

Standard Wiring:

C=Common of Switch to R and B.

1 =Feedback from actuator (24 Vac with actuator full CCW to 12 Vac at CW end).

R =Closes on temperature (pressure) drop and drives the actuator CCW (opens valve).

B =Closes on temperature (pressure) rise and drives the actuator CW (closes valve).

Typical Cooling Microtherm: TP-1031.

C =Common of switch to R and B.

1 =Feedback from actuator (24 Vac with actuator full CCW to 12 Vac at CW end).

R =Closes on temperature rise and drives the actuator CCW (opens valve).

B =Closes on temperature drop and drives the actuator CW (closes valve).

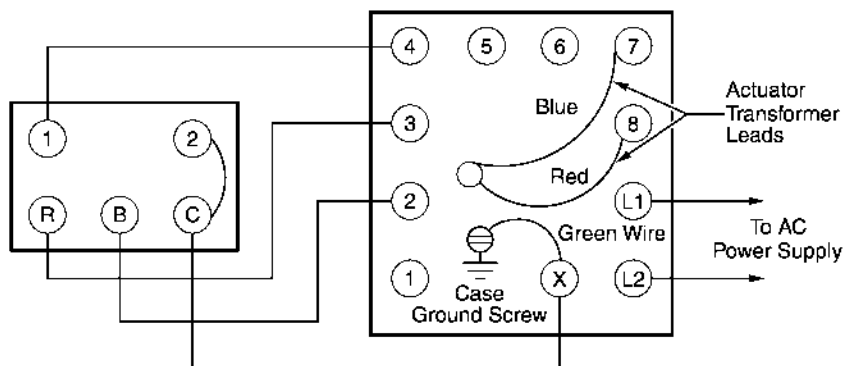

Figure-9 External Wiring of Microtherm Controller with Line Voltage Actuator – Standard Wiring.

Typical Actuators: MP-465, MP-475, MP-485, MP-486, MP-495, MP-2130-500, MP-2150-500, MP5-2151-500, MP5-4651, MP5-4751, MP-4851, and MP5-4851.

Typical Microtherm Controllers: PP-22X Series, TP-2XX Series, TP-3XX Series, TP-4XX Series, and TP-101X Series.

Reversed Wiring:

C =Common of switch to R and B.

1 =Feedback from actuator (12 Vac with actuator full CCW to 24 Vac at CW end).

R =Closes on temperature (pressure) drop and drives the actuator CW (closes valve).

B =Closes on temperature (pressure) rise and drives the actuator CCW (opens valve).

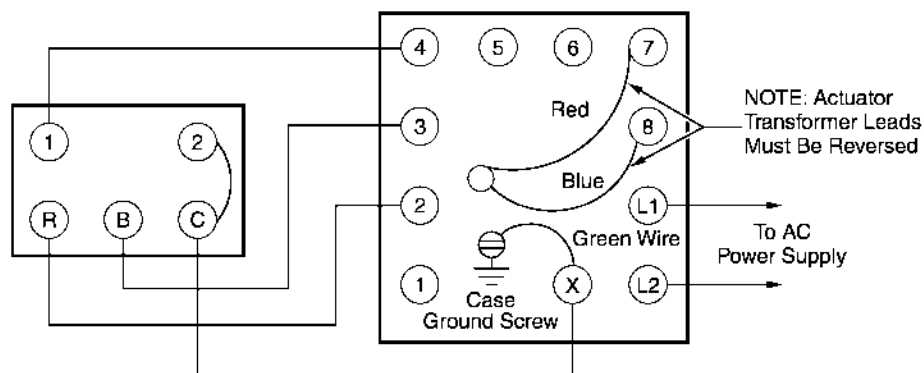

Figure-10 External Wiring of Microtherm Controller with Line Voltage Actuator – Reversed (Cooling) Wiring.

Typical Microtherm Controllers: TP-2XX Series, TP-3XX Series, and TP-4XX Series.

C =Common of switch to R and B.

1 =Feedback from actuator (24 Vac with actuator full CCW to 12 Vac at CW end).

R =Closes on temperature drop and drives the actuator CCW (closes damper).

B =Closes on temperature rise and drives the actuator CW (opens damper).

Cycle of Operation

With the fan running:

1. Rotates actuator to CCW end (damper closed).
2. Allows actuator to modulate between 33% from CCW end to CW (damper open).
3. Allows actuator to modulate between 50% from CCW end to CW (damper open).
4. Allows actuator to modulate between 67% from CCW end to CW (damper open).
5. Rotates actuator to CW end (damper open).

When the fan is off, the damper is closed.

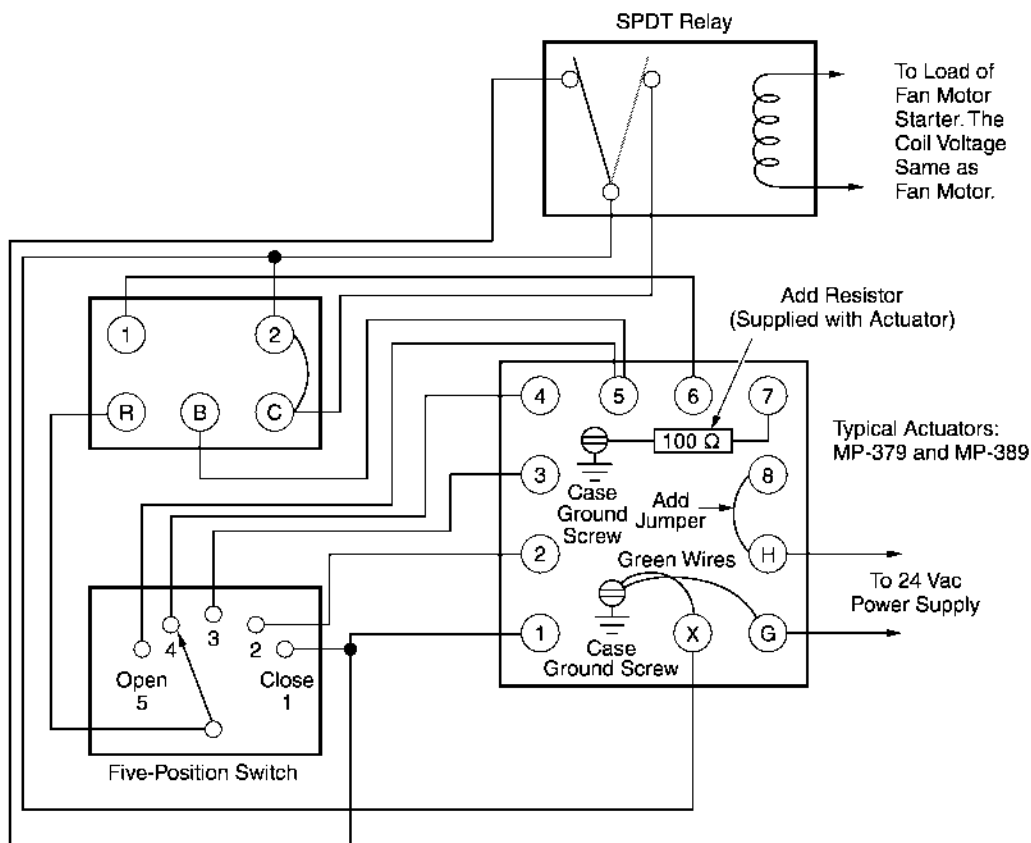

Figure-12 External Wiring for Microtherm Controller with Five-Position 24 Vac Actuators.

Typical Microtherm Controllers: TP-2XX Series, TP-3XX Series, and TP-4XX Series.

C =Common of switch to R and B.

1 =Feedback from actuator (24 Vac with actuator full CCW to 12 Vac at CW end).

R =Closes on temperature drop and drives the actuator CCW (closes damper).

B =Closes on temperature rise and drives the actuator CW (opens damper).

Cycle of Operation

With the fan running:

1. Rotates actuator to CCW end (damper closed).
2. Allows actuator to modulate between 33% from CCW end to CW (damper open).
3. Allows actuator to modulate between 50% from CCW end to CW (damper open).
4. Allows actuator to modulate between 67% from CCW end to CW (damper open).
5. Rotates actuator to CW end (damper open).

When the fan is off, the damper is closed.

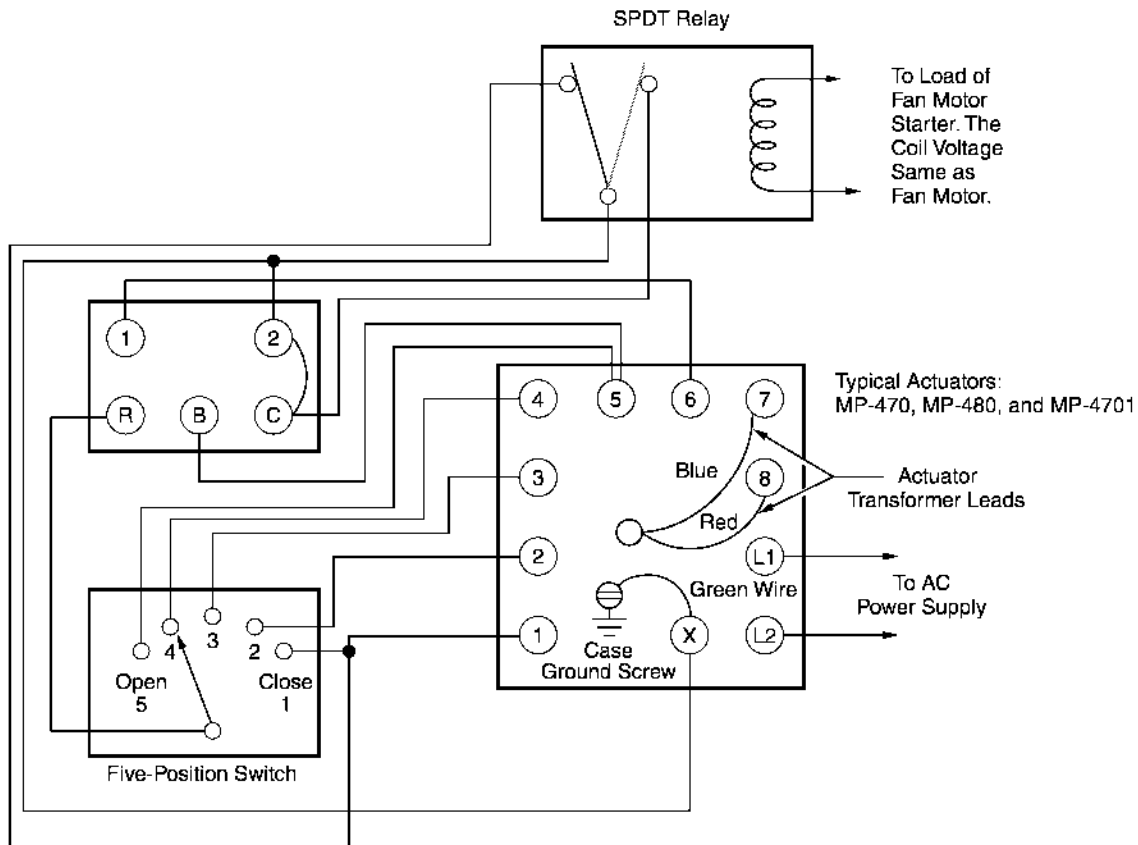

Figure-13 External Wiring for Microtherm Controller with Five-Position Line Voltage Actuator.

Typical Actuators which require AE-504 purchased separately: MP-361, MP-371, MP-382, and MP-2113-500.

Controlling potentiometer:
 135 Ω 1.5 watts min.: 1,000 Ω 3 watts min.,
 or AM-332 Actuator Potentiometer Kit.

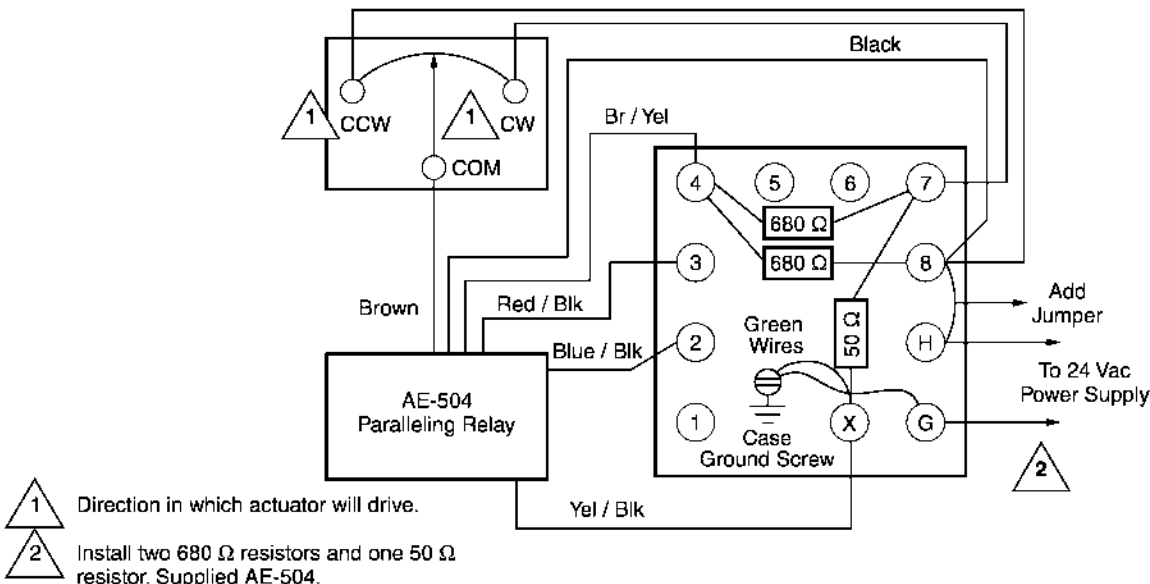

Figure-14 External Wiring for Slidewire Controller with 24 Vac Actuators.

Typical Actuators which require AE-504 purchased separately: MP-465, MP-475, MP-483, MP-485, MP-486, MP-495, MP-2130-500, MP-2150-500, MP5-4651, MP5-4751, MP-4851, MP5-4851.

Controlling potentiometer:
 135 Ω 1.5 watts min.: 1,000 Ω 3 watts min.,
 or AM-332 Actuator Potentiometer Kit.

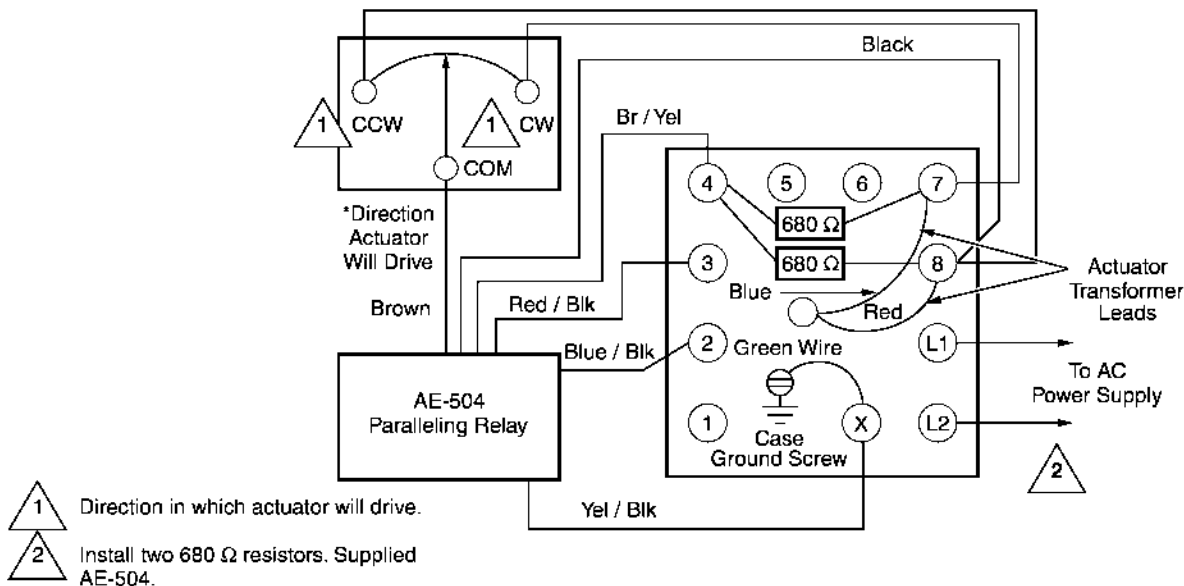

Figure-15 External Wiring for Slidewire Controller with Line Voltage Actuator.

Typical Actuators which require CP-8301-120 purchased separately:
 MP-421, MP-422, MP-423, MP-424, MP-451, MP-452, MP-454.

Typical Actuators with CP-8301-120 factory installed and wired: MP-461-600,
 MP-471-600, MP-481-600, MP-2110-601.

Note: CP-8301-120 is marked CP-8301-620 on factory assemblies.

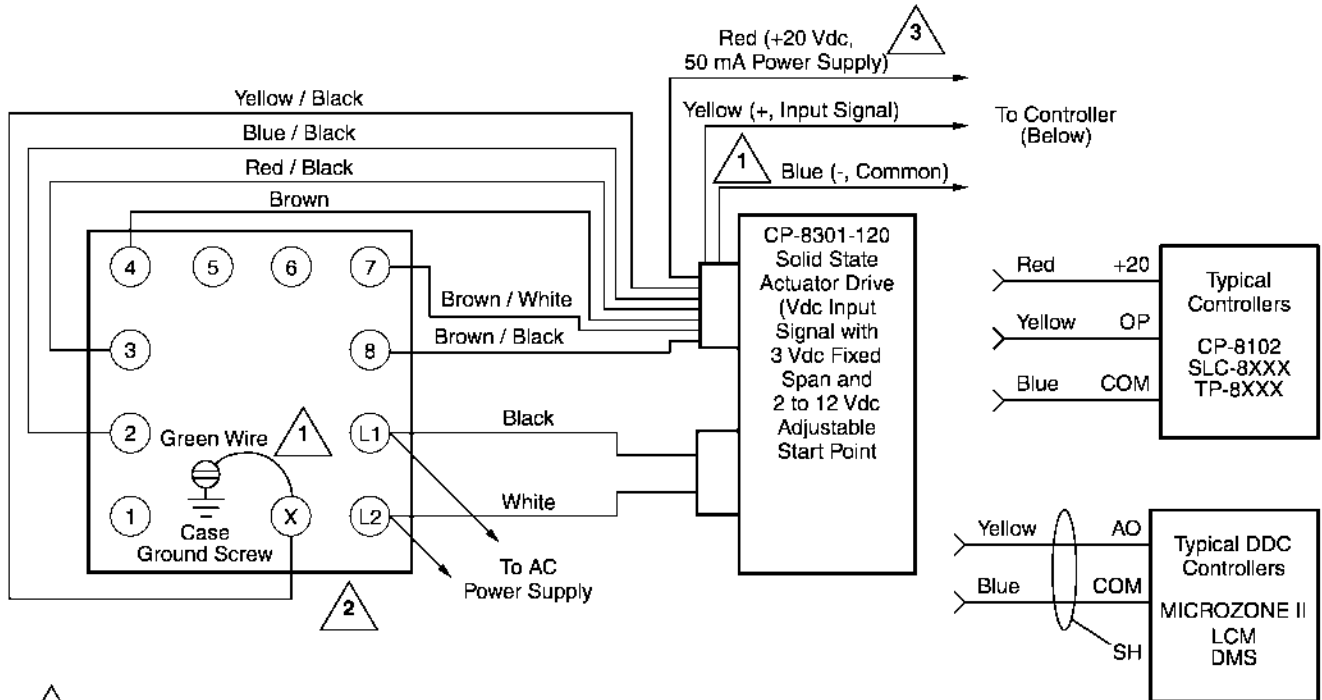
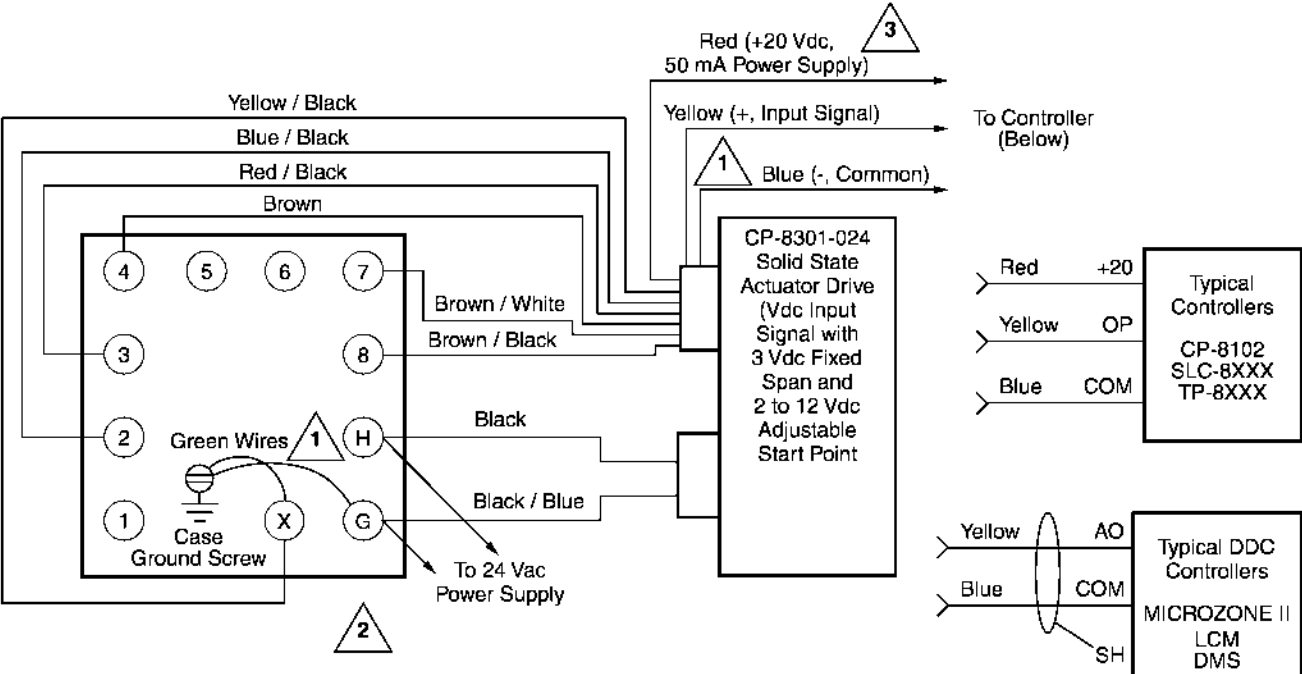

Figure-16 External Wiring for CP-8301-120, Vdc Interface with Line Voltage Actuators without Internal Transformer.

**Typical Actuators which require CP-8301-024 purchased separately:
MP-361, MP-371, MP-381, MP-382, MP-2113-500.**



- 1 The Blue wire on the CP-8301-024 is grounded. To unground the Blue wire, remove the Green jumper wire between terminal X and the case ground screw.
- 2 The actuator rotates clockwise on an increasing Vdc input signal between Blue (-, Common) and Yellow (+). To rotate the actuator counterclockwise on an increase in input signal, reverse the Blue/Black and Red/Black leads and reverse the Brown/Black and Brown/White leads.
- 3 Whenever it is not connected, tape off the red power supply lead from the CP-8301-024 actuator drive.

Figure-17 External Wiring for CP-8301-024, Vdc Interface with 24 Vac Actuators.

Typical Actuators which require CP-8301-120 purchased separately:
 MP-465, MP-475, MP-483, MP-485, MP-486, MP495, MP-2130-500,
 MP-2150-500.

Typical Actuators which require CP-8301-240 purchased separately:
 MP5-2151-500, MP5-4651, MP5-4751, MP-4851, MP5-4851.

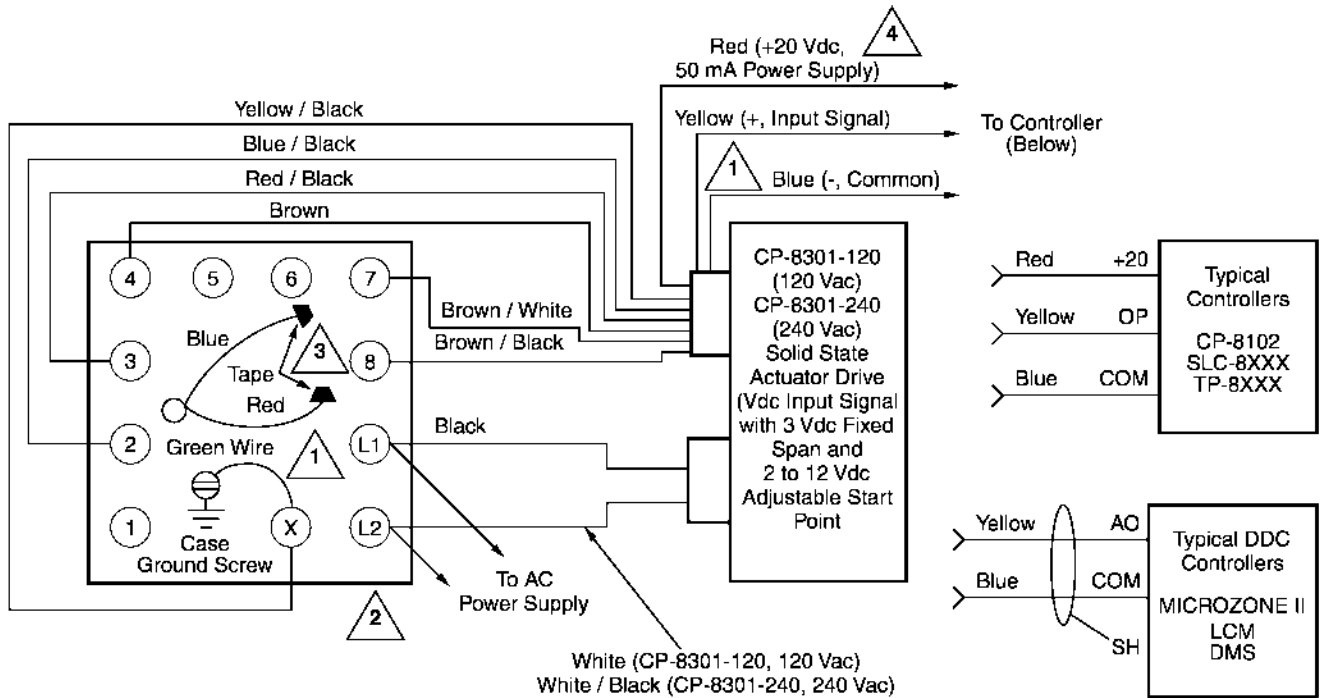

- 1 The Blue wire on the CP-8301-120 and CP-8301-240 is grounded. To unground the Blue wire, remove the Green jumper wire between terminal X and the case ground screw.
- 2 The actuator rotates clockwise on an increasing Vdc input signal between Blue (-, Common) and Yellow (+). To rotate the actuator counterclockwise on an increase in input signal, reverse the Blue/Black and Red/Black leads, and reverse the Brown/Black and Brown/White leads.
- 3 Remove Red and Blue actuator transformer leads from actuator terminals 7 and 8 and tape the leads off. On older actuators, remove back cover of actuator and cut and tape the leads from the transformer to the feedback transformer.
- 4 Whenever it is not connected, tape off the red power supply lead from the CP-8301-120 or CP-8301-240 actuator drive.

Figure-18 External Wiring for CP-8301-120 and CP-8301-240, Vdc Interface with Line Voltage Actuators with Internal Transformer.

**Typical Actuators which require CP-8391-913 purchased separately:
MP-361, MP-371, MP-381, MP-382, MP-2113-500.**

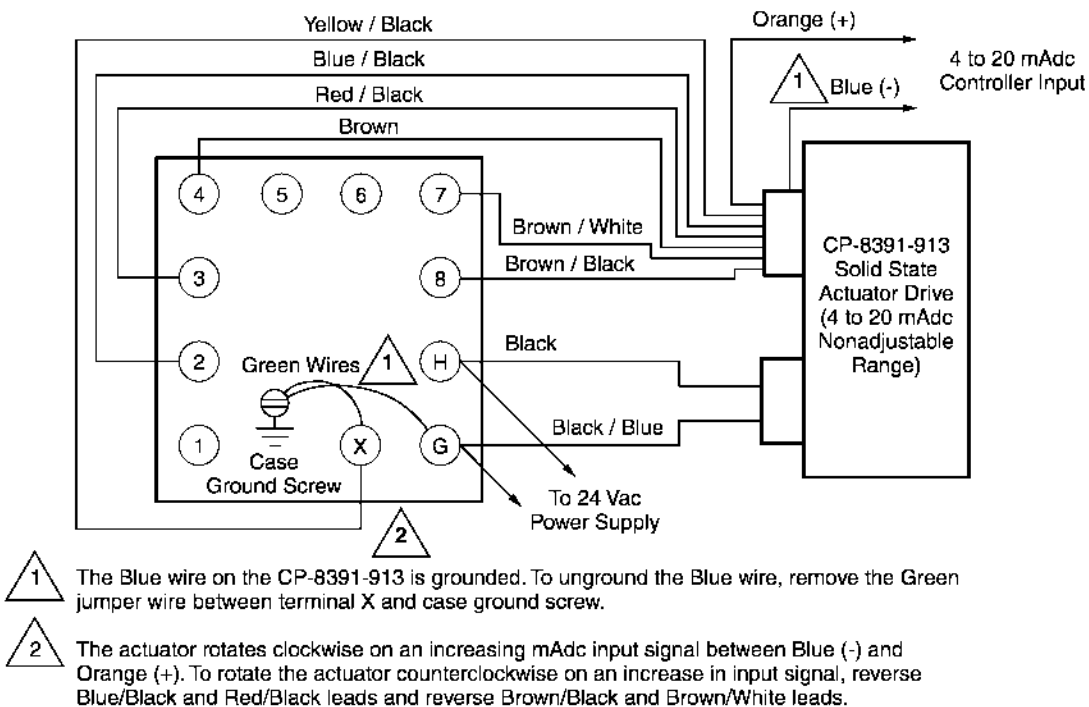

Figure-19 External Wiring for CP-8391-913, 4 to 20 mAdc Interface with 24 Vac Actuators.

**Typical Actuators which require CP-8391-910 purchased separately:
MP-421, MP-422, MP-424, MP-451, MP-452, MP-453, MP-454.**

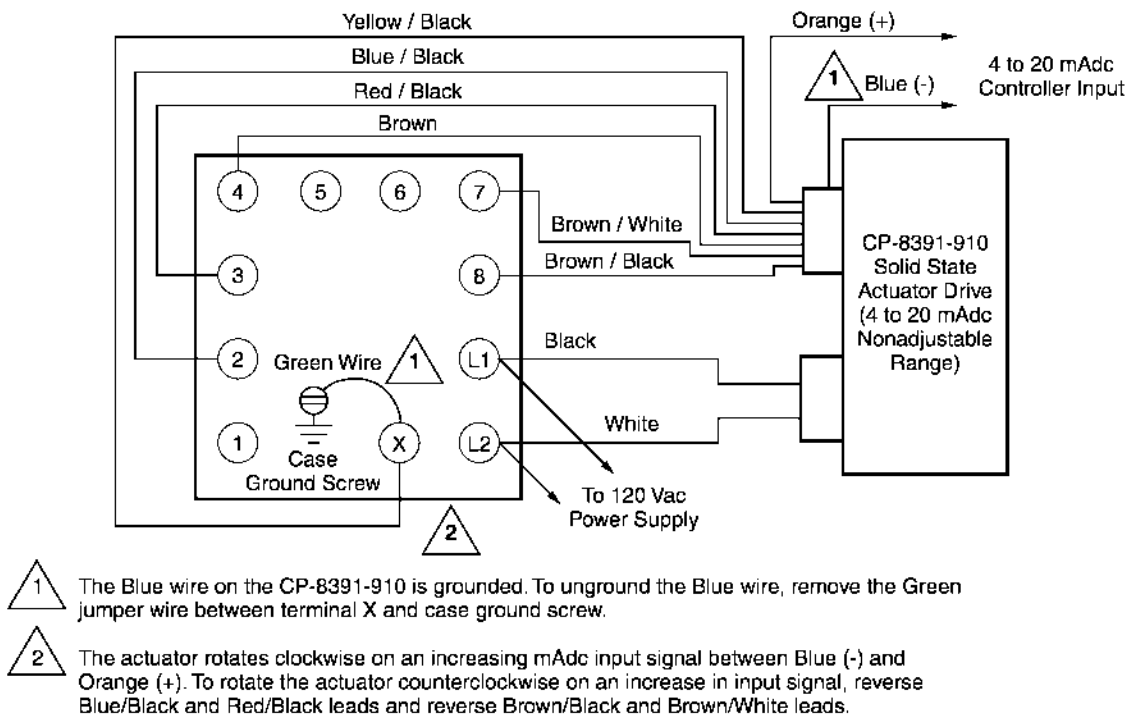
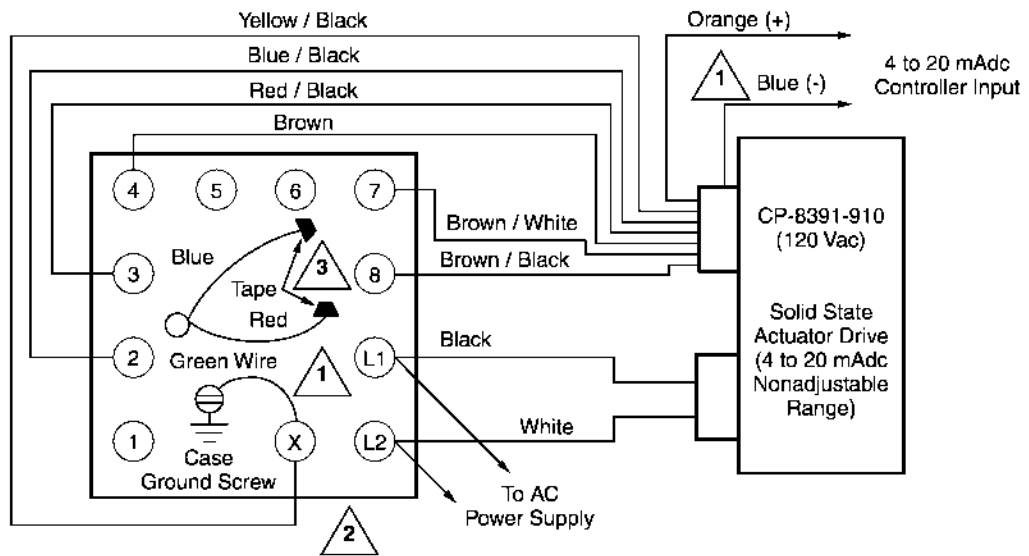

Figure-20 External Wiring for CP-8391-910, 4 to 20 mAdc Interface with Line Voltage Actuators without Internal Transformer.

Typical Actuators which require CP-8391-910 purchased separately:
 MP-465, MP-475, MP483, MP-485, MP-486, MP-495, MP-2130-500,
 MP-2150-500.



- 1 The Blue wire on the CP-8391-910 is grounded. To unground the Blue wire, remove the Green jumper wire between terminal X and case ground screw.
- 2 The actuator rotates clockwise on an increasing mAdc input signal between Blue (-) and Orange (+). To rotate the actuator counterclockwise on an increase in input signal, reverse Blue/Black and Red/Black leads and reverse Brown/Black and Brown/White leads.
- 3 Remove Red and Blue actuator transformer leads from actuator terminals 7 and 8 and tape the leads off. On older actuators, remove back cover of actuator and cut and tape the leads from the transformer to the feedback transformer.

Figure-21 External Wiring for CP-8391-910 and CP-8391-911, 4 to 20 mAdc Interface with Line Voltage Actuators with Internal Transformer.

Typical Actuators which require CP-8391-716 purchased separately:
 MP-421, MP-422, MP-423, MP-424, MP-451, MP-452, MP-453, MP-454.

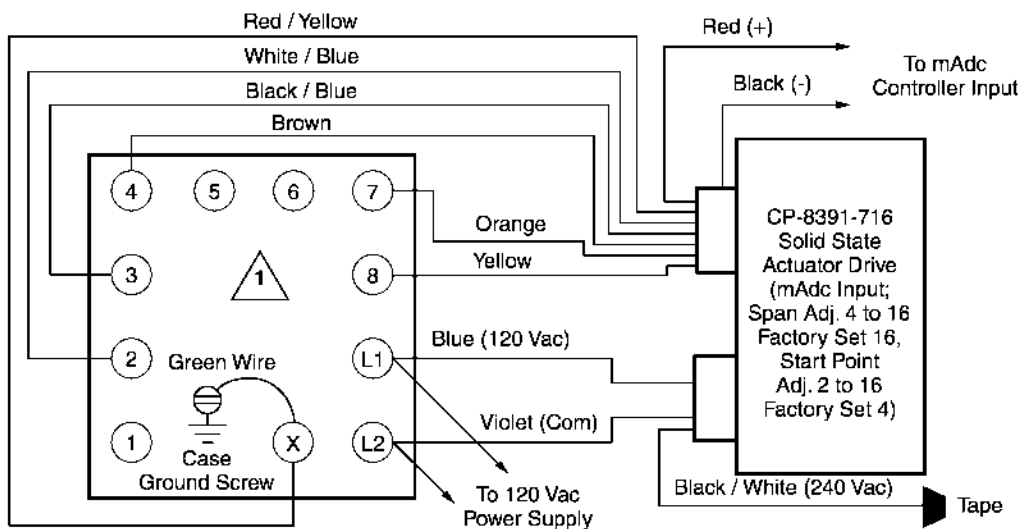

- 1 The actuator rotates clockwise on an increasing mAdc input signal between Black (-) and Red (+). To rotate the actuator counterclockwise on an increase in input signal, reverse Blue/Black and White/Blue leads and reverse Orange and Yellow leads.

Figure-22 External Wiring for CP-8391-716, mAdc Interface with Line Voltage Actuators without Internal Transformer.

Typical 120 Vac Actuators which require CP-8391-716 purchased separately:
 MP-465, MP-475, MP-483, MP-485, MP-486, MP-495, MP-2130-500,
 MP-2150-500.

Typical 240 Vac Actuators which require CP-8391-716 purchased separately:
 MP5-2151-500, MP5-4651, MP5-4751, MP-4851, MP5-4851.

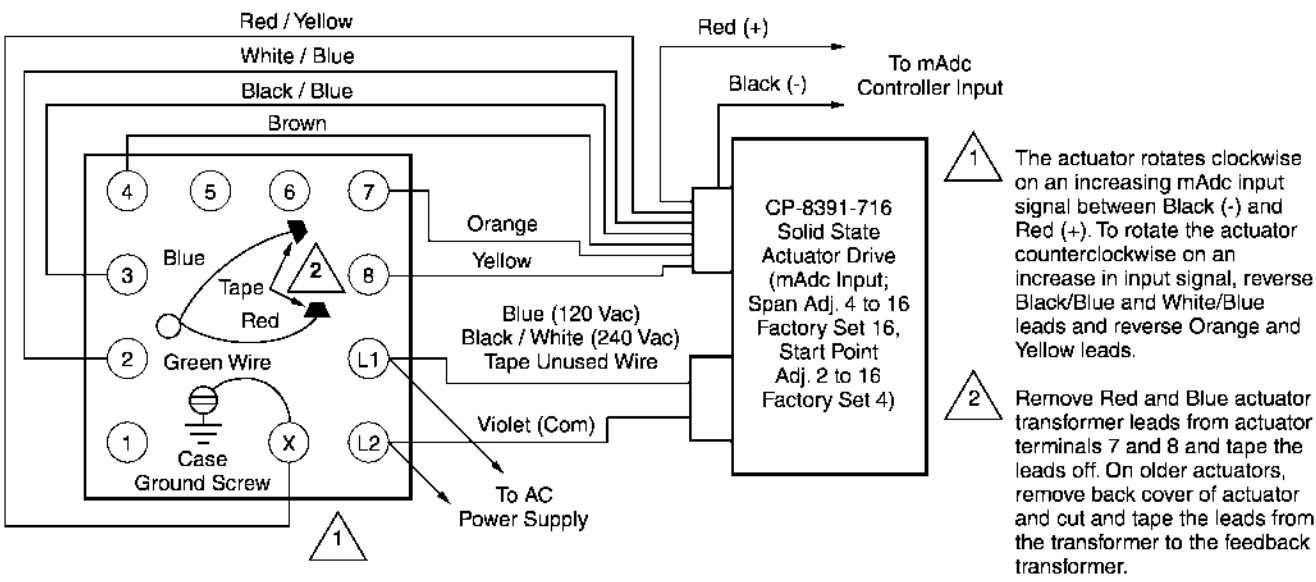

Figure-23 External Wiring for CP-8391-716, mAdc Interface with Line Voltage Actuators with Internal Transformer.

Typical Actuators: MP-361, MP-371, MP-381, and MP-382.

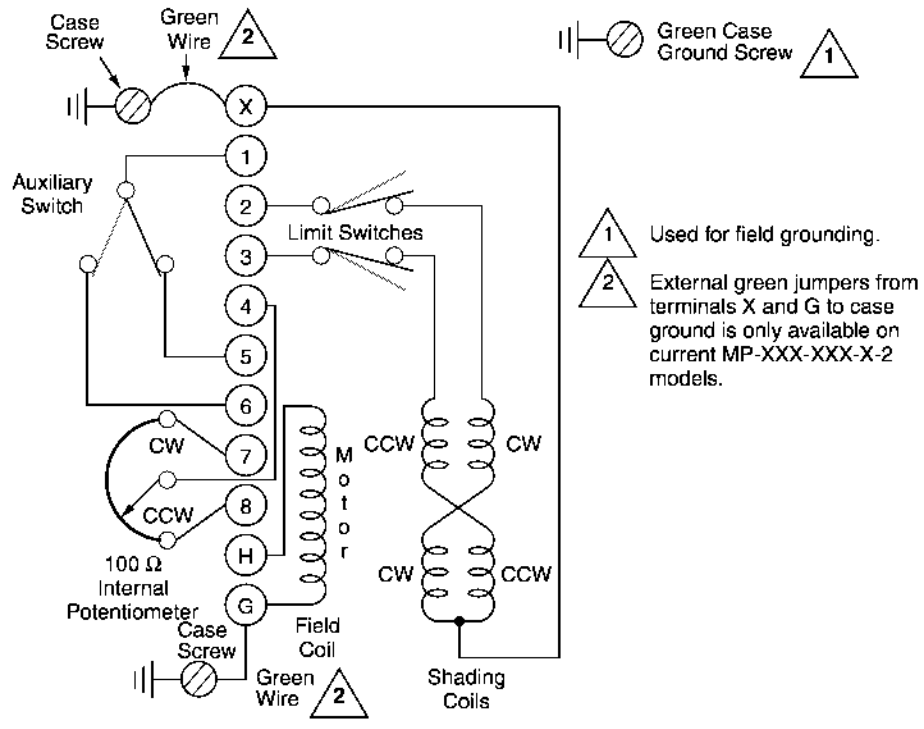

Figure-24 Internal Wiring for 24 Vac Actuator.

Typical Actuators: MP-421, MP-422, MP-423, MP-424, MP-451, MP-452, MP-453, MP-454, MP-461-600, MP-471-600, and MP-481-600.

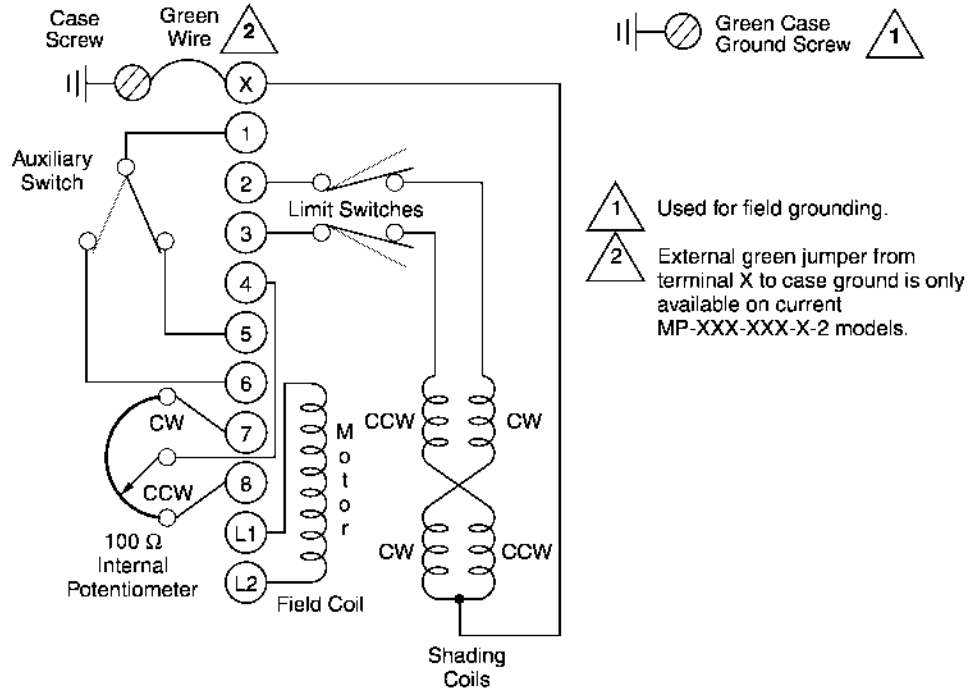

Figure-25 Internal Wiring for Line Voltage Actuators.

Typical Actuators: MP-465, MP-475, MP-483, MP-486, MP-495, MP5-4651, MP5-4751, MP-4851, and MP5-4851.

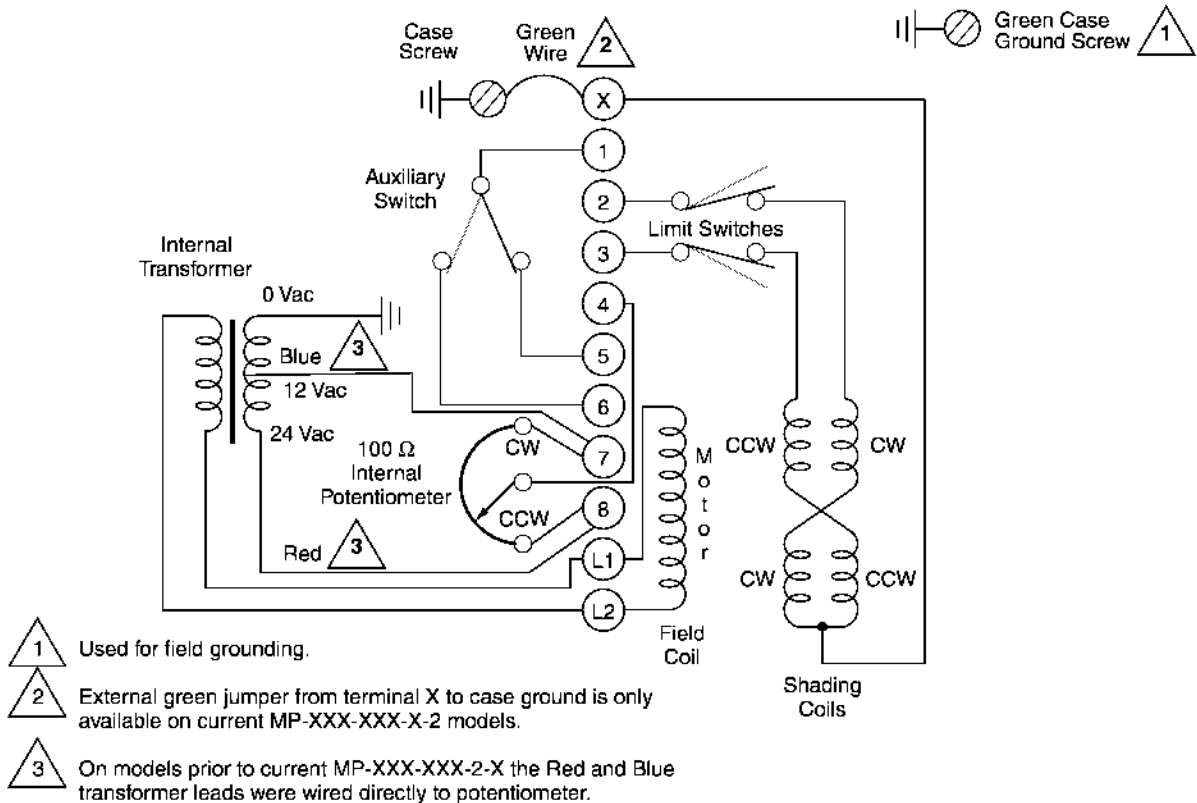

Figure-26 Internal Wiring for Line Voltage Actuator with Built-in Transformer.

Typical Actuator: MP-2113-500.

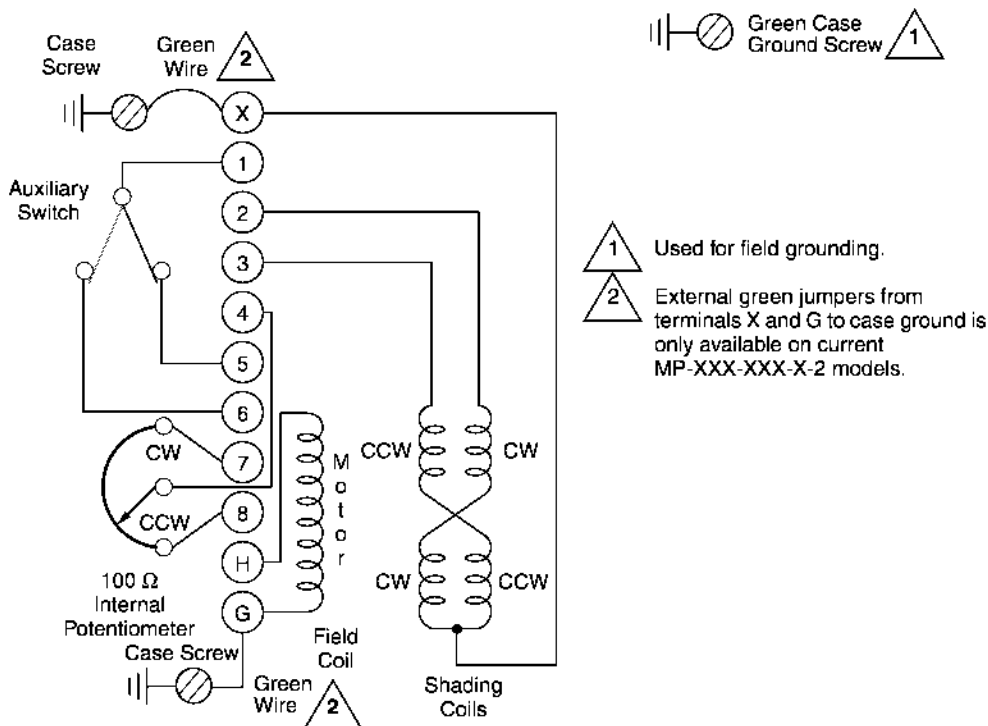

Figure-27 Internal Wiring for 24 Vac Actuator without Limit Switches (Actuator is Stall Type with Built-in Mechanical Stops).

Typical Actuator: MP-2110-600.

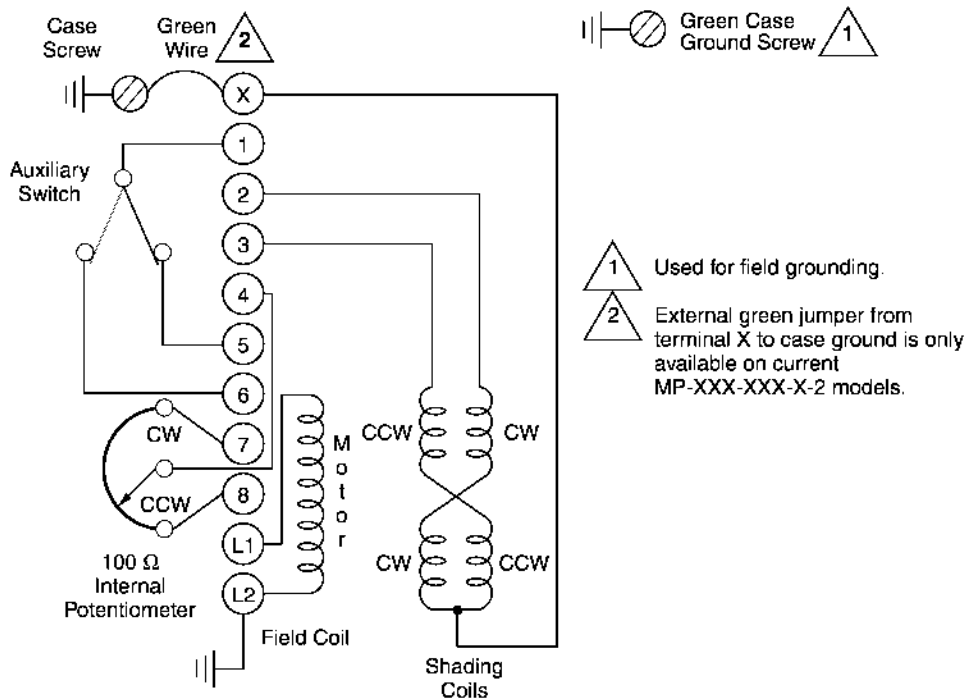

Figure-28 Internal Wiring for Line Voltage Actuators without Limit Switches (Actuator is Stall Type with Built-in Mechanical Stops.)

Typical Actuators: MP-2130-500, MP-2150-500, MP5-2151-500.

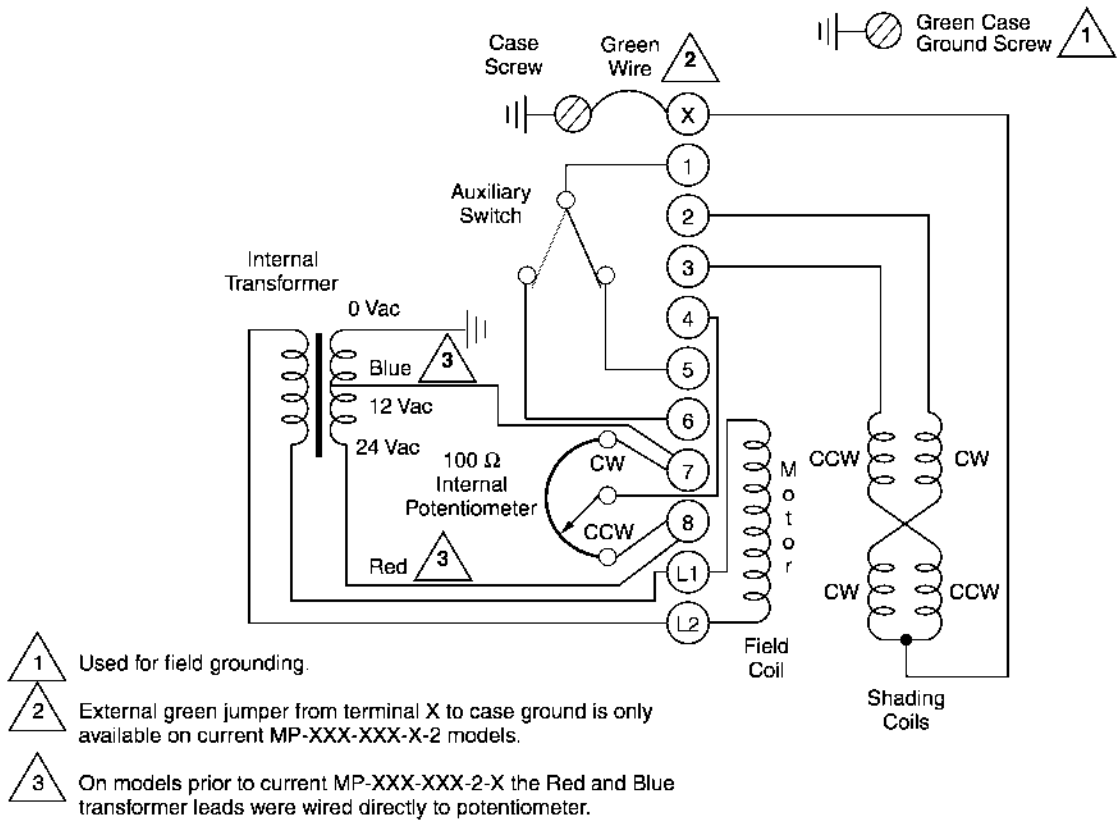

Figure-29 Internal Wiring for Line Voltage Actuators without Limit Switches and Built-in Transformer (Actuator is Stall Type with Built-in Mechanical Stops).

Typical Actuators: MP-379 and MP-389

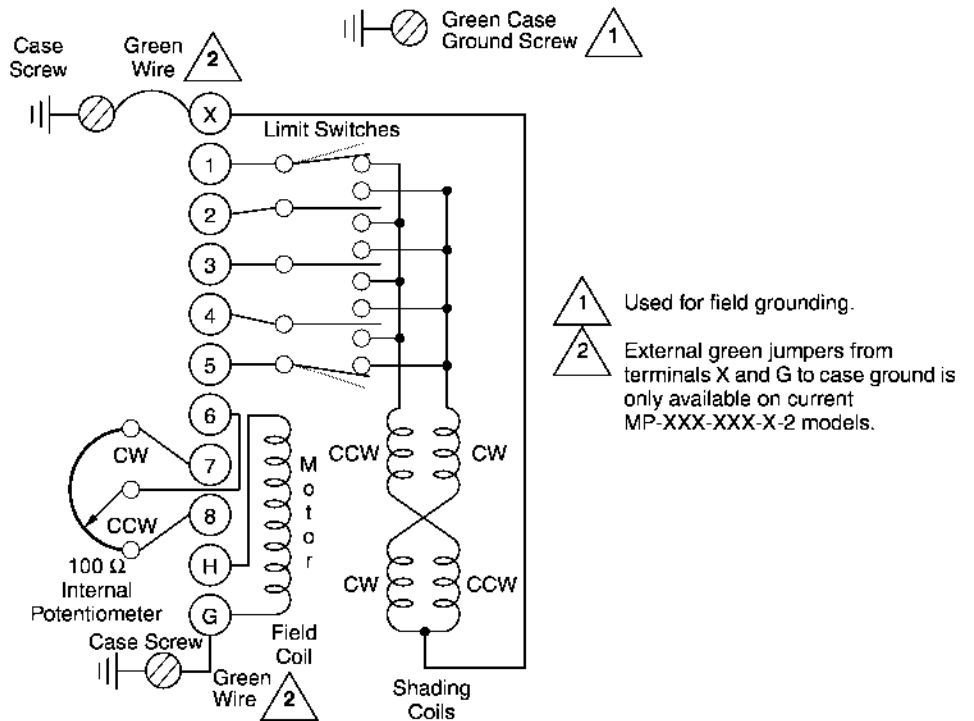

Figure-30 Internal Wiring for 24 Vac Five-Position Actuators.

Typical Actuators: MP-470, MP-480, and MP-4701.

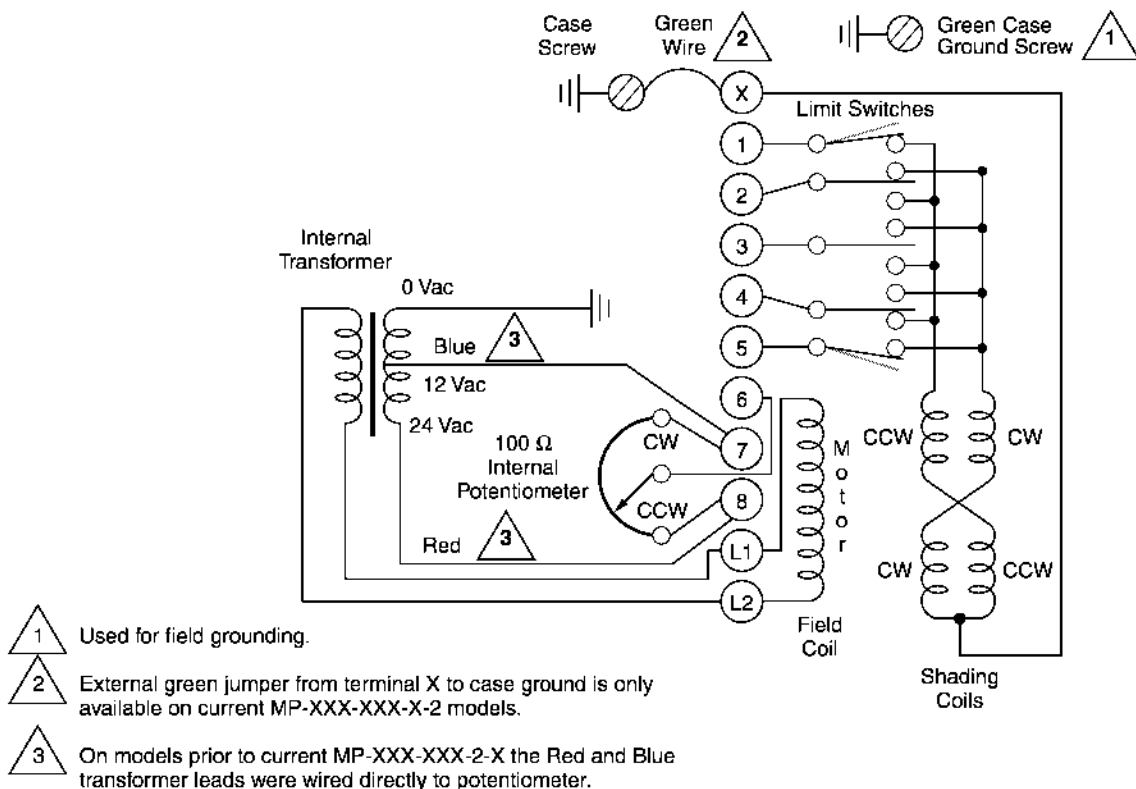

Figure-31 Internal Wiring for Line Voltage Five-Position Actuators.

Typical Actuators: MP-367, MP-377, and MP-387.

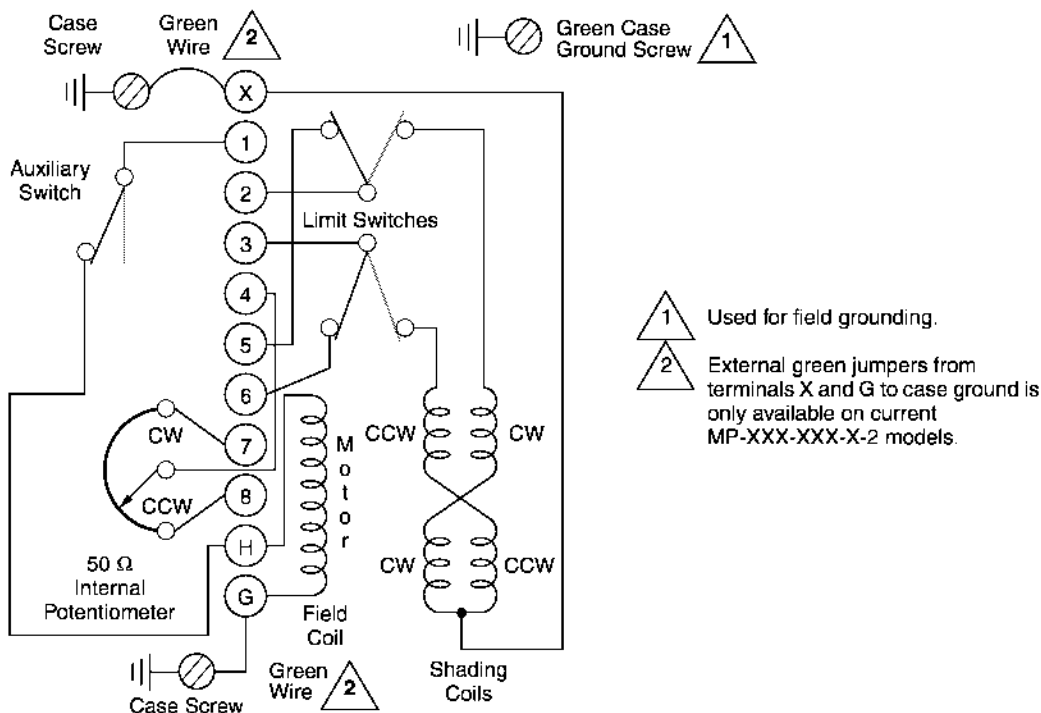

Figure-32 Internal Wiring for 24 Vac Sequencing Actuators.

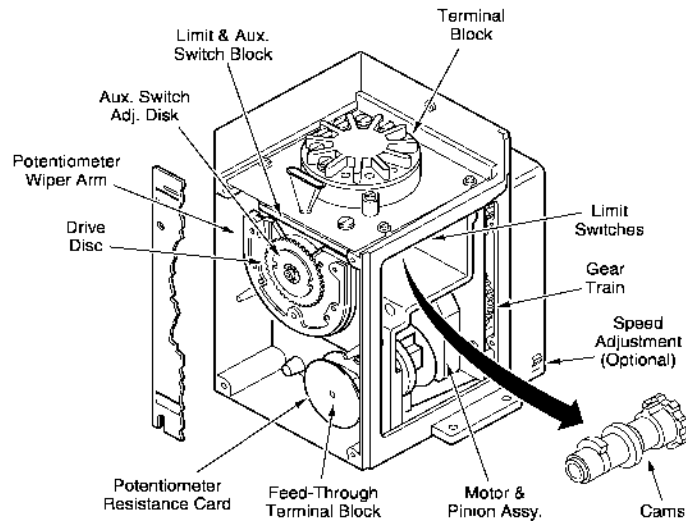

Figure-33 Internal View of a Typical Actuator.

INSTALLATION

Inspection

Inspect the package for damage. If damaged, notify the appropriate carrier immediately. If undamaged, open the package and inspect the device for obvious damage. Return damaged products.

Requirements

- Wiring diagrams
- Tools (not provided):
 - Digital volt-ohm meter (DVM)
 - Appropriate screwdriver(s) for cover, and mounting screws
 - Appropriate drill and drill bit for mounting screws
 - Appropriate wrenches for adjustment of damper and valve linkages
 - TOOL-201, Calibration kit for System 8000 (Vdc)
 - TOOL-209, 135 Ω slidewire and 0 to 7 mA manual positioner
- Appropriate accessories
- Mounting screws (not provided)
- Wire nuts (not provided)
- Training: Installer must be a qualified, experienced technician



Warning:

- Disconnect the power supply (line power) before installation to prevent electrical shock and equipment damage.
 - Make all connections in accordance with the wiring diagram and in accordance with national and local electrical codes. *Use copper conductors only.*
-

Caution:

- Do not exceed the ratings of the device(s).
 - Do not apply power to the unit unless the damper linkage and/or the valve assembly have been installed.
 - Avoid locations where excessive moisture, corrosive fumes, or vibration is present.
 - Do not install insulation on any part of the actuator.
-

European Standard EN 55022

Refer to Table-2 and Table-3 to identify applicable models.

Warning: This is a Class A (European Classification) product. In a domestic environment this product may cause radio interference in which case the user may be required to take adequate measures.

MOUNTING

Preferred mounting is with the actuator in an upright position in a weather protected area.

Note: The MP-21XX series requires upright mounting. The adjustable speed actuators cannot be mounted upside down, with the output shaft up or with speed adjustment screw pointing up.

It is recommended that valve actuators be mounted above the centerline of the valve body. When selecting a location, allow sufficient room for accessories and for service of the product.

Direction of Actuator Rotation

All references to the direction of actuator rotation are based on looking at the front of the actuator, where the splined output shaft extends from the front case of the actuator.

Linkage Assembly

Damper

Caution: The damper must not stop the actuator before it has reached its electrical limit of travel or permanent damage can occur to the actuator.

1. During installation of the linkage assembly, the actuator should be powered and be able to be controlled manually.
2. Mount the actuator in an appropriate position near the damper. Refer to Figure-35. Actuators must be linked to the damper so that it can complete its full stroke. Damper rod that is too long is not rigid enough for good control and damper rod that is too short makes it difficult to adjust the linkage.
3. Attach a balljoint to the actuator and damper crank arms at the correct position in the crank arm slot depending on the application. Refer to Figure-34, Table-7, and Table-8 for application settings. The use of 180° rotation damper actuators provides the best close-off at the end of stroke and the best controllability (turn down ratio).
4. Typically the damper should be linked for an angular rotation of less than 90° that provides the required flow (typically 60°). This provides the optimum close-off and controllability.

Table-7 Balljoint Position on Actuator and Damper Crank Arms with 180 Degree Rotation Actuators.

| Desired Damper Rotation | Balljoint Position on Actuator Crank Arm | Balljoint Position on Damper Crank Arm |
|-------------------------|--|--|
| 90° | Prick Point (2-1/4") | End of Slot (3-1/8") |
| 80° | 2" | End of Slot (3-1/8") |
| 70° | 1-3/4" | 3" |
| 60° | 1-1/2" | 3" |

Table-8 Balljoint Positioning Actuator and Damper Crank Arms with 90 Degree Rotation Actuators.

| Desired Damper Rotation | Balljoint Position Actuator Crank Arm | Balljoint Position Damper Crank Arm |
|-------------------------|---------------------------------------|-------------------------------------|
| 90° | End of Slot (3-1/8") | End of Slot (3-1/8") |
| 80° | 2-3/4" | 3" |
| 70° | 2-1/2" | 3" |
| 60° | Prick Point (2-1/4") | End of Slot (3-1/8") |

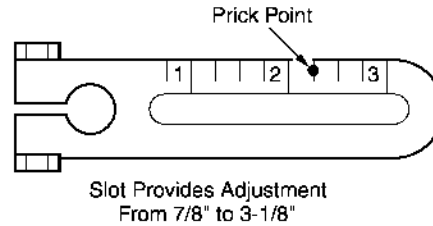

Figure-34 Proper Balljoint Position on Crank Arm.

5. With the actuator powered, manually position the actuator to the position that is required for the closed position of the damper. Rotate the damper to its midstroke position. Referring to Figure-36 and Figure-37, install the crank arms on the damper shaft and the actuator so that crank arms are parallel. The crank arm on damper shaft should be secured to the shaft and the crank arm on the actuator should be free to rotate.
6. Attach the push rod to the ball joint connectors on both crank arms and tighten the ball joint screws only thumb tight.
7. Rotate by hand the crank arm on the actuator to drive the linkage and the damper shaft through its full stroke to ensure proper damper action.
8. Return the damper to its closed position and tighten to secure the actuator crank arm.
9. While pushing the damper closed, tighten the ball joint screws to secure the damper rod.
10. Run the actuator back and forth through its full stroke and check for proper damper and linkage operation. Adjust the linkage if required.

Caution: If the crank arm does not provide proper travel, reset the linkage. Never attempt to turn the actuator shaft with a wrench or a crank; this may damage the actuator.

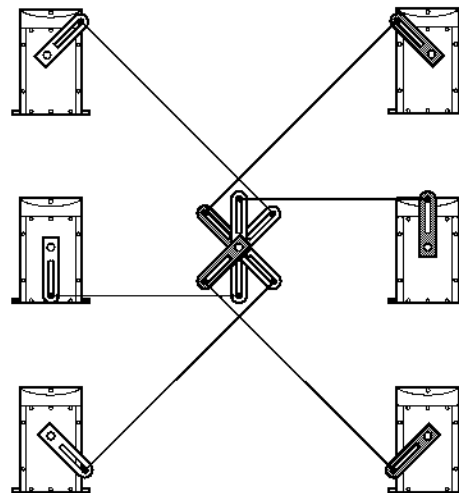

Figure-35 Typical Actuator Mounting Positions.

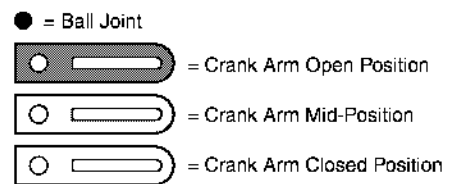
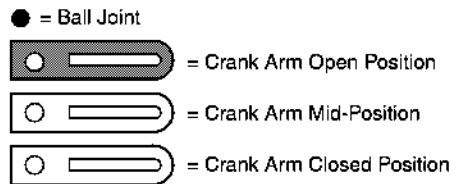
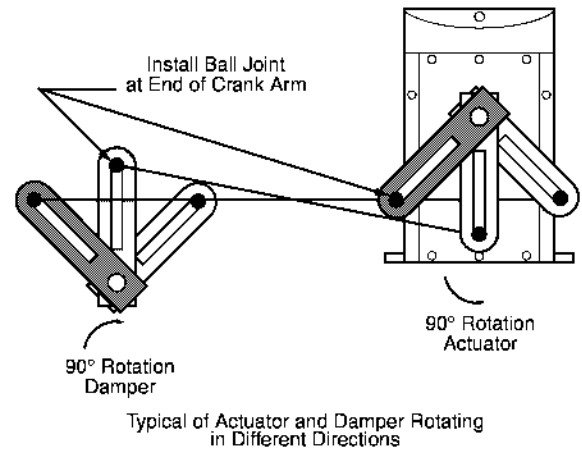
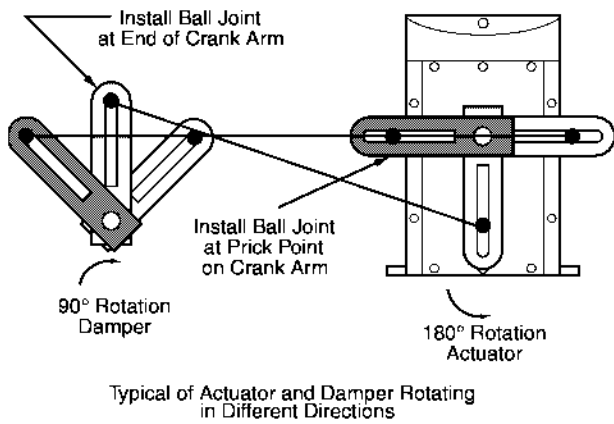
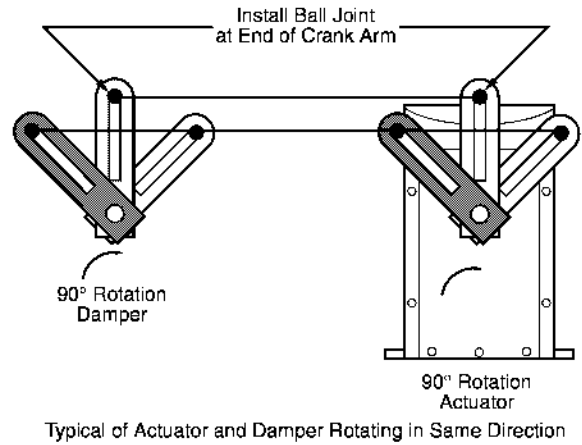
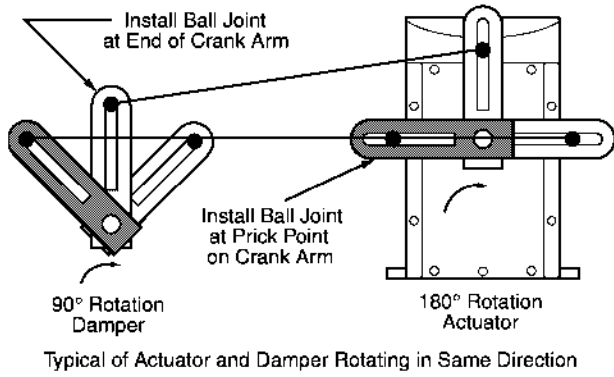

Figure-36 Typical Damper Linking with 180 Degree Rotation Actuator.

Figure-37 Typical Damper Linking with 90 Degree Rotation Actuator.

Valve

For the correct installation of valve linkages, refer to the "Accessories" section for form numbers of the appropriate linkage instruction sheets.

WIRING

The wiring connectors are made to coded screw terminals. Actuators with "-600" suffixes also have 6" (152 mm) color coded leads for control circuit.

Power Wiring

All actuators include a barrier that separates the power wiring compartment from the low voltage wiring compartment. Refer to Table-9 for allowable circuit class for the two wiring compartments.

Table-9 Actuator Circuit Class.

| Typical Part Numbers | Actuator Description | Power Wiring Compartment | | Low Voltage Wiring Compartment | |
|--|----------------------------|---|--|---|--|
| | | Terminals (Function) | Circuit Class for Power Wiring Compartment | Terminals (Function) | Circuit Class for Low Voltage Wiring Compartment |
| MP-361, MP-371, MP-381, MP-382, MP-2113-500 | Low Voltage Proportional | H&G (24 Vac Power) 1, 5, and 6 (Auxiliary Switch) | 1. May be Class 2 circuit if auxiliary switch is wired to 24 Vac or is not used. 2. Must be Class 1 circuit if auxiliary switch is wired to line voltage. | X, 2, and 3 (Control Circuit) 4, 7, and 8 (Potentiometer) | May be Class 2 Circuit. |
| MP-421, MP-422, MP-423, MP-424, MP-451, MP-452, MP-453, MP-454, MP-461-600, MP-465, MP-471-600, MP-475, MP-481-600, MP-483, MP-485, MP-486, MP-495, MP-2150-500, MP5-4651, MP5-4751, MP-4851, MP5-4851 | Line Voltage Proportional | L1 and L2 (Line Voltage Power) 1, 5, and 6 (Auxiliary Switch) | Must be Class 1 circuit. | X, 2, and 3 (Control Circuit) 4, 7, and 8 (Potentiometer) | May be Class 2 Circuit. |
| MP-367, MP-377, MP-387 | Low Voltage Sequencing | H&G (24 Vac Power) 1, 5, and 6 (Control Switches) | May be Class 2 Circuit. | X, 2, and 3 (Control Circuit) 4, 7, and 8 (Potentiometer) | May be Class 2 Circuit. |
| MP-379, MP-389 | Low Voltage Five-Position | H&G (24 Vac Power) 6, 7, and 8 (Potentiometer) | May be Class 2 Circuit. | X, 1, 2, 3, 4, 5 (Control Circuit) | May be Class 2 Circuit. |
| MP-470, MP-480, MP-4701 | Line Voltage Five-Position | H&G (24 Vac Power) 6, 7, and 8 (Potentiometer) | Must be Class 1 Circuit. | X, 1, 2, 3, 4, 5 (Control Circuit) | May be Class 2 Circuit. |

Refer to Table-10 for selection of proper gage wire versus length of wire run (one run has two wires).

Table-10 Power Wire Selection.

| Actuator Series | Voltage | Wire Size (AWG) | Maximum Run ft. (m) |
|--------------------------------|---------|-----------------|---------------------|
| MP-36X, MP-37X | 24 Vac | 14 | 115 (35) |
| | | 12 | 180 (55) |
| | | 10 | 285 (87) |
| MP-38X | 24 Vac | 14 | 130 (40) |
| | | 12 | 205 (62) |
| | | 10 | 325 (99) |
| MP-42X MP-445-304 MP-45X | 120 Vac | 14 | 810 (247) |
| | | 12 | 1275 (388) |
| | | 10 | 2040 (622) |
| MP-46X MP-47X MP-48X | 120 Vac | 14 | 1050 (320) |
| | | 12 | 1660 (506) |
| | | 10 | 2650 (808) |
| MP-4XX1 | 240 Vac | 14 | 3340 (1018) |

When multiple 24 Vac actuators are powered from the same transformer, the actuators must be in phase. Connect the same transformer lead to the "G" terminal on all actuators and same transformer lead to the "H" terminal on all actuators.

Control Wiring

Refer to Figure-3 through Figure-23 for typical wiring of the actuators. Refer to the actuator selection tables beginning on page 3, for an index of External Wiring Figures versus actuator models and control signals. The requirements for the field control wiring are shown below.

SPST Control Signal

Refer to Figure-3 and Figure-4. Since the SPST switch is controlling the power to the actuator, the control wiring is limited to the power wiring shown above.

SPDT Control Signal

Refer to Figure-5 and Figure-6. Use 18 gage wire for runs up to 1,000 ft. (305 m) between the actuator and the SPDT switch. Use larger gage wires on longer runs.

Microtherm Control

Refer to External Wiring Figure-7 through Figure-13. Use 18 gage wire for runs up to 1,000 ft. (305 m) between the actuator and the Microtherm controller. Use larger gage wires on longer runs.

135 to 1000 Ω Slidewire Control

Refer to External Wiring Figure-14 and Figure-15. Use 18 gage three-conductor twisted leads (part number W-103 or equal) for runs up to 500 ft. (152 m) between the actuator and the slidewire controller. Use larger gage wires for longer runs.

Voltage Vdc (System 8000) Control

Refer to External Wiring Figure-16 through Figure-18. Use 18 gage three-conductor twisted leads (part number W-103 or equal) for runs up to 1,000 ft. (305 m) between the actuator and the Vdc (System 8000) controller. Use larger gage wires for longer runs.

Caution: Use 18 gage three-conductor shielded cable (twisted) when it is necessary to install the control leads in the same conduit with power wiring, or when high RFI/EMI generating devices are near. Do not connect the shield to earth ground or any leads or terminals.

Current mAdc Control

Refer to External Wiring Figure-19 through Figure-23. Use 18 gage two-conductor twisted leads (part number W-102 or equal) for runs up to 500 ft. (152 m) between the actuator and the slidewire controller. Use larger gage wires for longer runs.

Direct Digital Control (DDC)

DDC controllers may be used to control these actuators according to one of the methods described below.

SPST Control

Refer to External Wiring Figure-5 and Figure-6. Requires two digital output points programmed as a drive open, drive closed configuration. The digital output must be rated for switching 0.9 amp at 24 Vac.

Voltage Vdc Control

Refer to External Wiring Figure-16, Figure-17, and Figure-18. Requires an analog output from the DDC controller, programmed to provide the desired voltage range. Also requires a CP8301-120 electronic actuator drive between the DDC controller and the actuator.

Current mAdc Control

Refer to External Wiring Figure-19, Figure-20, and Figure-21. Requires an analog output from the DDC controller, programmed to provide the desired current range (usually 4 to 20 mA). Also requires a CP8391-913 electronic actuator drive between the DDC controller and the actuator.

ADJUSTMENTS

Limit Switch Adjustment

The counterclockwise limit switch on certain actuators provides adjustable travel of 45° to 320° rotation. The actuator selection tables beginning on page 3 identify the models that have adjustable travel limits. To adjust travel refer to Figure-38 and Figure-39 while following the steps shown below.

Note: The feedback potentiometers in the actuator have a fixed rotation (typically either 90° or 180°). Therefore, adjusting the travel of the actuator could affect the feedback to the controller. The potentiometer has a slip clutch and will not be damaged by adjusting the actuator travel. If the actuator travels beyond the limit of the potentiometer, the wiper arm on the potentiometer will cease to rotate. The wiper arm will instantly start moving in the opposite direction as soon as the actuator reverses direction.

1. Remove the top cover from the actuator and disconnect the field wiring from terminals, X, 2, and 3 of the actuator.
2. The actuator should be powered and driven to its CW limit by shorting terminal X to terminal 2. Refer to Figure-38.

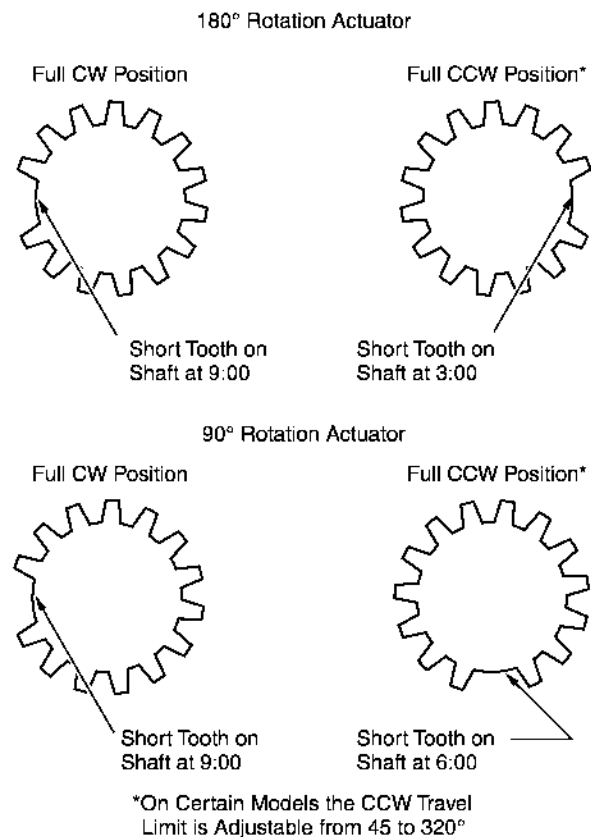

Figure-38 Actuator Output Shaft Position (Front View).

3. The access hole for the travel adjustment is located in the top plate of the actuator directly ahead of terminal block in the front of the actuator (where output shaft extends from actuator). Refer to Figure-39.

4. Insert a screwdriver through the access hole and engage the notched cam nearest the front of the actuator.

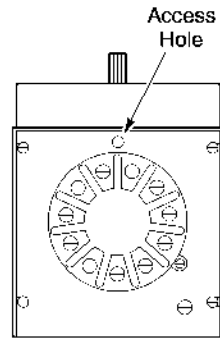

Figure-39 Limit Switch Adjustment.

5. Turning the cam CW (as seen from the front of the actuator) increases the length of the actuator rotation. Each click of the cam represents about a 3° change in actuator rotation.
6. After adjusting the cam, check the rotation of the actuator by shorting actuator terminal X to terminal 3 to drive the actuator to its new CCW limit setting.
7. If the travel is not what is desired, repeat steps 2 through 6 until desired results are obtained.

Auxiliary Switch Adjustment

Refer to the actuator selection tables beginning on page 3 for the actuators that include an auxiliary switch. The adjustable SPDT auxiliary switch is actuated by the cam nearest the back of the actuator. It is factory set to switch near the CW end of actuator rotation. Terminal 1, the common of the switch, is made to terminal 5, from the CCW end of rotation until the switch point, then terminal 1 is made to terminal 6 for rest of the stroke.

Note: The auxiliary switch is made from terminal 1 to terminal 5 when the switch follower is on the low part of the cam, and from terminal 1 to terminal 6 when the switch follower is on the lobe of the cam.

To adjust the switch point of the auxiliary switch, follow the steps shown below.

Note: If the actuator travel has been increased beyond 180°, the auxiliary switch may, depending on its switch point, operate twice in the actuator stroke.

1. Remove the top cover of the actuator.
2. The actuator should be powered and positioned to desired point in actuator stroke for the auxiliary switch to operate.
3. The access hole for the auxiliary switch adjustment is located in top plate of the actuator directly ahead of the terminal block in the back of the actuator. Refer to Figure-40. Actuators manufactured after 1976 have plastic funnel shield inserted in the access hole.

Caution: Disconnect the power to the actuator at the power terminals (H and G or L1 and L2) plus the auxiliary switch terminals (1, 5, and 6). More than one disconnect may be required.

4. Insert a screwdriver through the plastic funnel shield, if present, and through the access hole, engaging the screwdriver with the gear-like plastic disc.

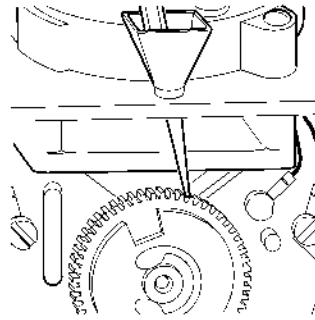

Figure-40 Auxiliary Switch Adjustment (Rear View with Top and Back Covers of Actuator Removed).

5. Turning the disc CW (as viewed from the front of the actuator) causes the switch to operate nearer to the CCW end of actuator rotation. Each click of the cam represents about a 3° change in the switch point.
6. Adjust the disc so that the switch just operates.

Speed Adjustment

The actuator selection tables beginning on page 3 list the actuators that are adjustable speed. The timing of the adjustable speed actuators is varied by a slotted adjustment screw on the lower left side of the front housing. Refer to Figure-41. Turning the screw CW decreases the speed. Total timing can be increased to about ten times the normal. Take care not to turn the adjustment screw too far CW as this will stall, but not damage, the actuator. If stalling occurs, turn the screw CCW until the actuator resumes operation. The total adjustment is normally 3-1/2 turns on the adjustment screw.

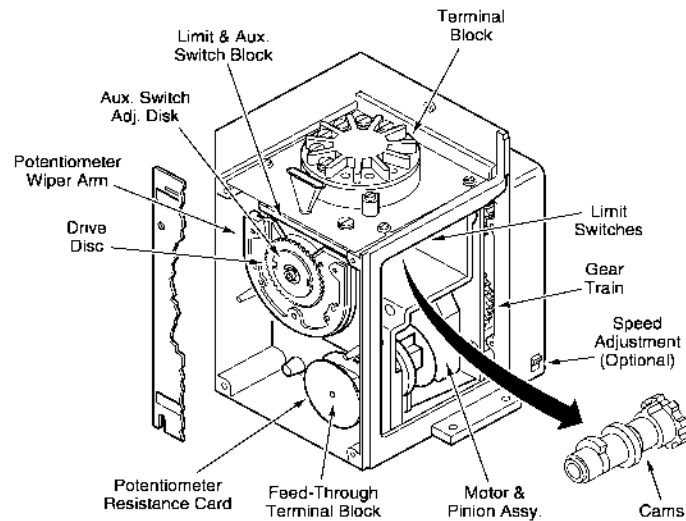

Figure-41 Speed Adjustment Location.

CHECKOUT

After the entire system has been installed and the actuator has been powered up, the following checks can be made for proper system operation.

GO, NO GO Test

Slidewire Controller with 24 Vac Actuators

Refer to Figure-14.

1. Disconnect field wiring from Brown lead of AE-504 and terminals 7 and 8 of the actuator.
2. Apply 24 Vac power to terminals H and G of the actuator.
3. Short the Brown lead of AE-504 to terminal 7 of actuator and the actuator should rotate CW to its limit.
4. Short the Brown lead of AE-504 to terminal 8 of actuator and the actuator should rotate CCW to its limit.
5. If the unit passes steps 3 and 4, the actuator and the AE-504 are good. If the unit does not pass steps 4 and 5, proceed to step 6.
6. Unhook the AE-504 leads from actuator terminals X, 2, and 3.
7. Short actuator terminal X to 2 and the actuator should rotate CW to its limit.
8. Short actuator terminal X to 3 and the actuator should rotate CCW to its limit.

If the unit passes steps 7 and 8, the actuator is good and AE-504 is defective. If the unit does not pass steps 7 and 8, the actuator is defective and the AE-504 may be good.

Slidewire Controller with Line Voltage Actuator

Refer to Figure-15.

1. Disconnect field wiring from Brown lead of AE-504 and terminals 7 and 8 of the actuator.
2. Apply proper AC power to terminals L1 and L2 of the actuator.
3. Short the Brown lead of AE-504 to terminal 7 of actuator and the actuator should rotate CW to its limit.
4. Short the Brown lead of AE-504 to terminal 8 of actuator and the actuator should rotate CCW to its limit.
5. If the unit passes steps 3 and 4, the actuator and the AE-504 are good. If the unit does not pass steps 4 and 5, proceed to step 6.
6. Unhook the AE-504 leads from actuator terminals X, 2, and 3.
7. Short actuator terminal X to 2 and the actuator should rotate CW to its limit.
8. Short actuator terminal X to 3 and the actuator should rotate CCW to its limit.

If the unit passes steps 7 and 8, the actuator is good and AE-504 is defective. If the unit does not pass steps 7 and 8, the actuator is defective and the AE-504 may be good.

CP-8301-120, Vdc Interface (System 8000) with Line Voltage Actuators without Internal Transformer

Refer to Figure-16.

1. Disconnect field wiring from Red, Yellow, and Blue leads of CP-8301-XXX.
2. Apply 120 Vac power to terminals L1 and L2 of the actuator.
3. Short the Yellow and Red leads of CP-8301-XXX and the actuator should rotate CW to its limit, unless rewired to rotate CCW on an increase in input signal.
4. Short the Yellow and Blue leads of CP-8301-XXX and the actuator should rotate CCW to its limit, unless rewired to rotate CCW on an increase in input signal.
5. If the unit passes steps 3 and 4, the actuator and the CP-8301-XXX are good. If the unit does not pass steps 3 and 4, proceed to step 6.
6. Unhook the CP-8301-XXX leads from actuator terminals X, 2, and 3.
7. Short actuator terminal X to 2 and the actuator should rotate CW to its limit.

8. Short actuator terminal X to 3 and the actuator should rotate CCW to its limit.

If the unit passes steps 7 and 8, the actuator is good and CP-8301-XXX is defective. If the unit does not pass steps 7 and 8, the actuator is defective and the CP-8301-XXX may be good.

CP-8301-024, Vdc Interface (System 8000) with 24 Vac Actuators

Refer to Figure-17.

1. Disconnect field wiring from Red, Yellow, and Blue leads of CP-8301-XXX.
2. Apply 24 Vac power to terminals H and G of the actuator.
3. Short the Yellow and Red leads of CP-8301-XXX and the actuator should rotate CW to its limit, unless rewired to rotate CCW on an increase in input signal.
4. Short the Yellow and Blue leads of CP-8301-XXX and the actuator should rotate CCW to its limit, unless rewired to rotate CCW on an increase in input signal.
5. If the unit passes steps 3 and 4, the actuator and the CP-8301-XXX are good. If the unit does not pass steps 3 and 4, proceed to step 6.
6. Unhook the CP-8301-XXX leads from actuator terminals X, 2, and 3.
7. Short actuator terminal X to 2 and the actuator should rotate CW to its limit.
8. Short actuator terminal X to 3 and the actuator should rotate CCW to its limit.

If the unit passes steps 7 and 8, the actuator is good and CP-8301-XXX is defective. If the unit does not pass steps 7 and 8, the actuator is defective and the CP-8301-XXX may be good.

CP-8301-120 and CP-8301-240, Vdc Interface (System 8000) with Line Voltage Actuators with Internal Transformer

Refer to Figure-18.

1. Disconnect field wiring from Red, Yellow, and Blue leads of CP-8301-XXX.
2. Apply AC power to terminals L1 and L2 of the actuator.
3. Short the Yellow and Red leads of CP-8301-XXX and the actuator should rotate CW to its limit, unless rewired to rotate CCW on an increase in input signal.
4. Short the Yellow and Blue leads of CP-8301-XXX and the actuator should rotate CCW to its limit, unless rewired to rotate CCW on an increase in input signal.
5. If the unit passes steps 3 and 4, the actuator and the CP-8301-XXX are good. If the unit does not pass steps 3 and 4, proceed to step 6.
6. Unhook the CP-8301-XXX leads from actuator terminals X, 2, and 3.
7. Short actuator terminal X to 2 and the actuator should rotate CW to its limit.
8. Short actuator terminal X to 3 and the actuator should rotate CCW to its limit.

If the unit passes steps 7 and 8, the actuator is good and CP-8301-XXX is defective. If the unit does not pass steps 7 and 8, the actuator is defective and the CP-8301-XXX may be good.

CP-8391-XXX Series mAdc Interface

Refer to Figure-19 through Figure-23.

1. Unhook the CP-8391-XXX leads from actuator terminals X, 2, and 3.
2. Refer to specific actuator for power hook-ups.
3. Short actuator terminal X to 2 and the actuator should rotate CW to its limit.
4. Short actuator terminal X to 3 and the actuator should rotate CCW to its limit.
5. If the unit passes steps 3 and 4, the actuator is good.

Positioning the Actuator with the Controller

If the sensed media is within the controller's setpoint range, the actuator can be positioned by adjusting the controller setpoint up and down. Check for proper operation of the actuator (valve or damper) while the actuator is being stroked.

Manually Positioning with Calibration Kit

TOOL-209, 135 Ω Slidewire Manual Positioner. Refer to Figure-14 and Figure-15.

1. Disconnect the field wiring from the Brown lead of the AE-504 and terminals 7 and 8 of the actuator.
2. Set the switch on TOOL-209 to 135 position.
3. Attach the Red lead of TOOL-209 to Brown lead of AE-504 and Blue and Yellow/White leads of TOOL-209 to terminals 7 and 8 respectively of the actuator.
4. The actuator can be manually positioned by turning the knob of TOOL-209.
5. Check for proper operation of the valve or damper as the actuator is operated.
6. Disconnect TOOL-209 and reconnect the field wiring.

TOOL-201, Calibration Kit for System 8000, Vdc Input

Refer to Figure-16 through Figure-18.

1. Disconnect the field wiring from the Red, Yellow, and Blue leads of CP-8301-XXX.
2. Attach the Red, Yellow, and Blue leads of TOOL-201 to the same color leads on the CP-8301-XXX.
3. The actuator can be manually positioned by turning the knob of TOOL-201.
4. Check for proper operation of the valve or damper as the actuator is operated.
5. Disconnect TOOL-201 and reconnect the field wiring.

Theory of Operation

Actuator variations are shown in Figure-24 through Figure-32. Refer to the actuator selection tables beginning on page 3 to determine which Internal Wiring Figure applies to a certain actuator.

The actuators are powered by shaded pole motors that are of the induction type, using what is commonly known as a squirrel cage rotor. These motors, like all single phase induction motors, must be provided with some means of starting. This is accomplished by the shading coils in the poles of the motor and hence the name "Shaded Pole." However, unlike most single phase induction motors, the shading coils are also essential for running.

The field coil produces a magnetic field in the iron core (stator) and in the rotor. When actuator terminal X is shorted to a terminal attached to CW shading coils, it causes a lag in part of the field which provides the equivalent of a rotating field. This rotating field induces a voltage and current in the rotor bars, and the attraction between the rotating field and these current carrying bars pulls the rotor around with the field in a CW direction. When actuator terminal X is shorted to a terminal attached to CCW shading coils, it operates the same except it drives the actuator CCW. A voltage of 24 to 30 Vac with current of 9 amps is induced in the shading coils in much the same manner as the secondary of a transformer.

REPLACEMENT PARTS

Table-11 Potentiometer Kit.

| Actuator | Potentiometer Kit | |
|--------------------------------|-------------------|-------------|
| | Part No. | Description |
| MP-XX0X-0-0-1 MP-XX0X-0-2-1 | ADDA-902-2 | 100 Ω, 180° |
| MP-XX1X-0-0-1 | ADDA-902-2 | 100 Ω, 180° |
| MP-XX2X-0-0-1 | ADDA-902-2 | 100 Ω, 180° |
| MP-XX3X-0-0-1 MP-XX3X-0-2-1 | ADDA-902-5 | 100 Ω, 90° |
| MP-XX4X-0-0-1 MP-XX4X-0-2-1 | ADDA-902-5 | 100 Ω, 90° |
| MP-XX5X-0-0-1 MP-XX5X-0-2-1 | ADDA-902-2 | 100 Ω, 180° |
| MP-XX6X-0-0-1 MP-XX6X-0-2-1 | ADDA-902-2 | 100 Ω, 180° |
| MP-XX7X-0-0-1 | ADDA-902-4 | 50 Ω, 180° |
| MP-XX8X-0-0-1 MP-XX8X-0-2-1 | ADDA-902-2 | 100 Ω, 180° |
| MP-XX9X-0-0-1 | ADDA-902-2 | 100 Ω, 180° |

Table-12 Additional Potentiometer Kits.

| Potentiometer Kits | |
|--------------------|---------------------------|
| Part No. | Description |
| ADDA-902-6 | 500 Ω, 90° |
| ADDA-902-7 | 50 Ω, 90° |
| ADDA-902-8 | 1000 Ω, 90° |
| ADDA-902-9 | 500 Ω, 180° |
| ADDA-902-10 | 1000 Ω, 180° |
| ADDA-907 | Shaft seal and gasket kit |

MAINTENANCE

Regular maintenance of the total system is recommended to assure sustained, optimum performance.

The actuators require a minimum of maintenance since the motor and gear train are submerged in oil for continuous lubrication and cooling. If it is necessary to refill the actuator with oil, always use Siebe Environmental Controls immersion oil (one quart, part number BYZP-195). Refill capacity is 1-1/4 pints. For best performance, oil level (with the actuator upright) should be up to the edge of the oil fill hole in the front case of the actuator. Refer to **Material Safety Data Sheet MSDS-4**.

TROUBLESHOOTING

Refer to Section "GO, NO GO Test" on page 38.

FIELD REPAIR

Normally the actuators are replaced or returned for factory repair. However, certain field repairs can be performed. Contract your local Siebe Environmental Controls (SEC) outlet for replacement part information.

DIMENSIONAL DATA

Refer to Figure-42 and Figure-43.

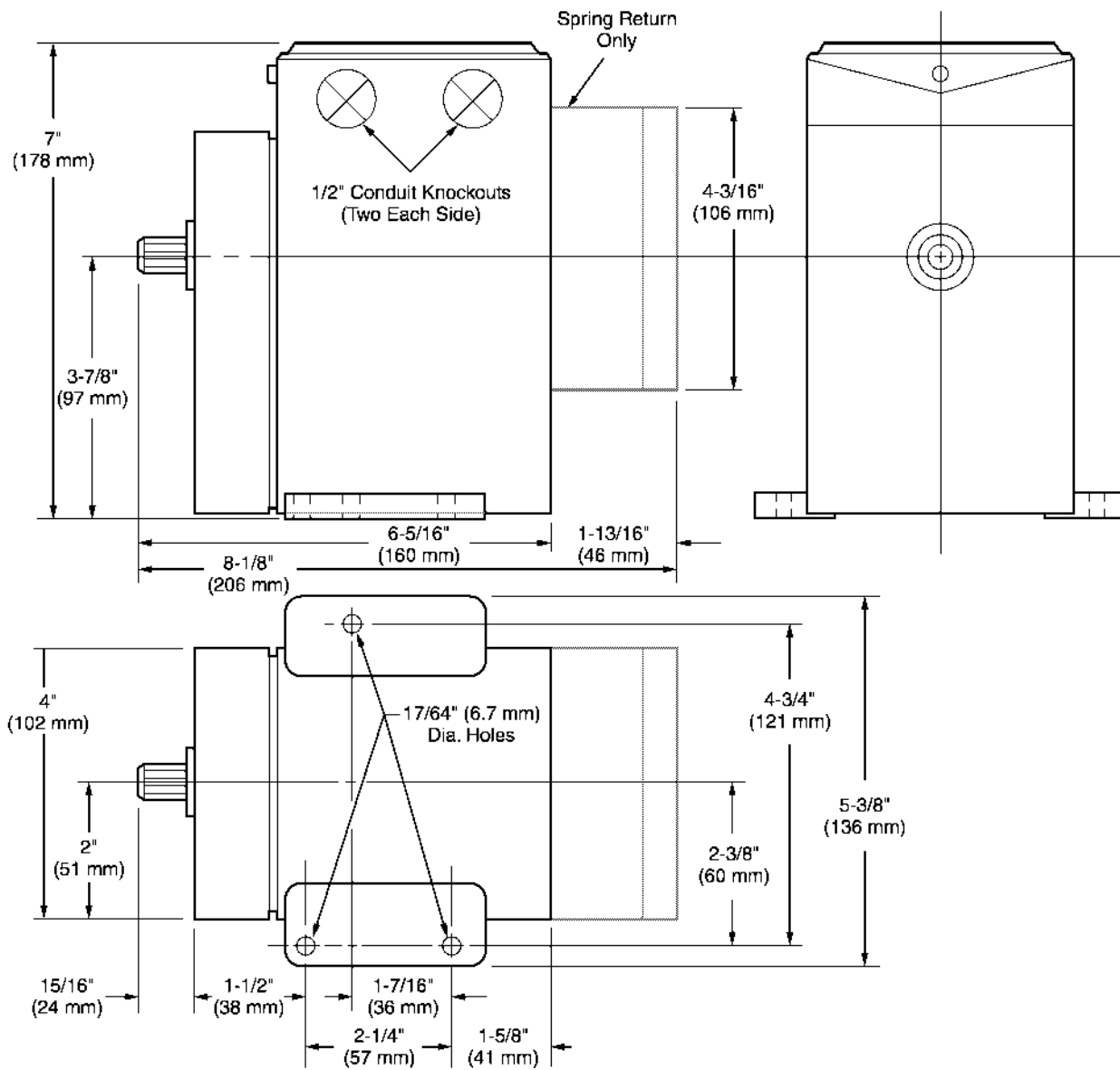

Figure-42 Dimensional Drawing for MP-3XX, MP-4XX, MP-2XXX, and MP-4XXX.

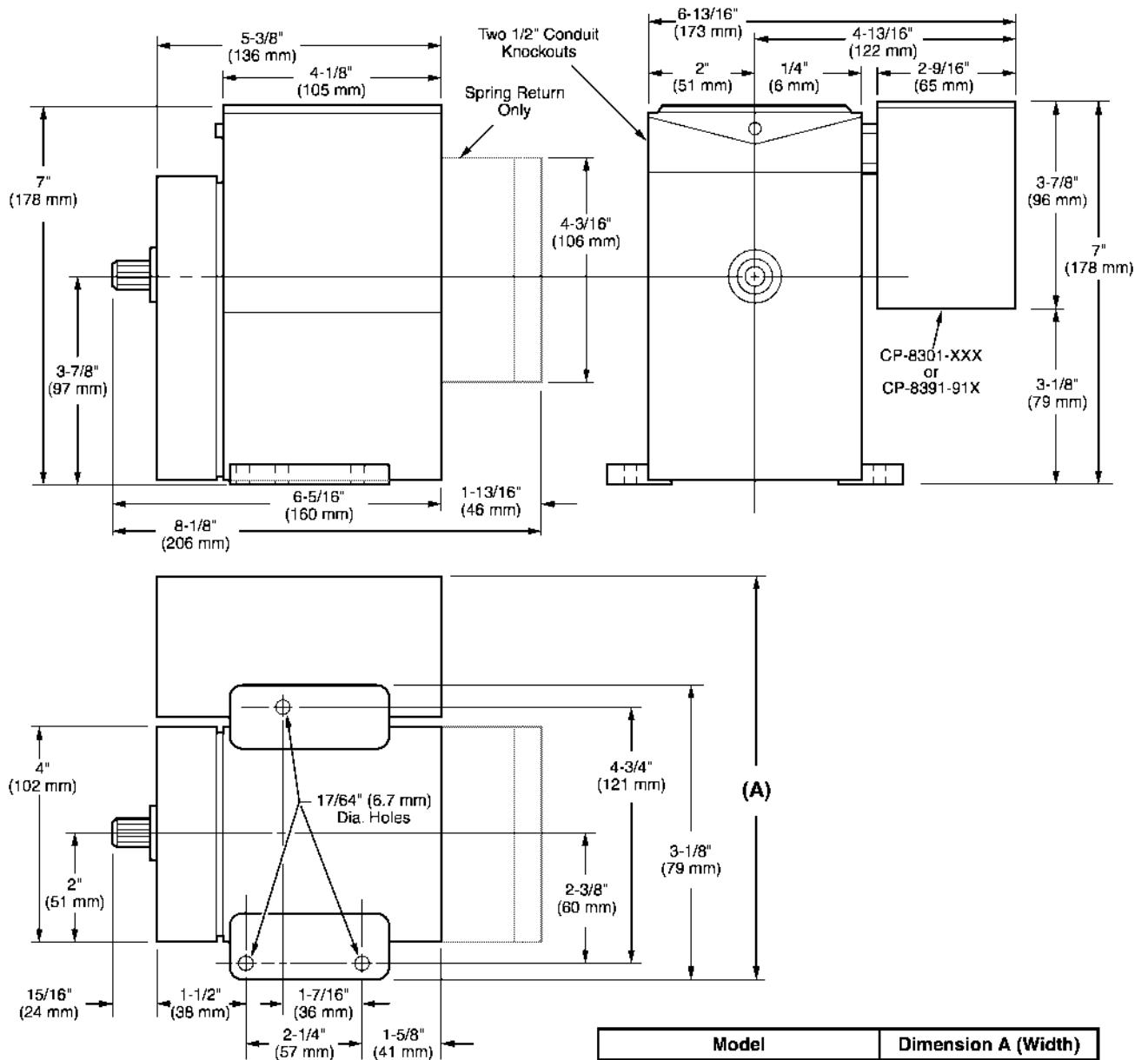

Figure-43 Dimensional Drawing for MP-3XX, MP-4XX, MP-2XXX, and MP-4XXX with -6XX Suffix (CP-8301-XXX or CP-8391-91X Installed) or with AE-504 Installed.

Microtherm and MICROZONE II are registered trademarks, and System 8000 and LCM are trademarks, of Invensys Building Systems Inc.