

**1/2" to 2" Valve Packing Kits
 Installation Instructions**

Application

The YBA-622-2 and YBA-622-2-0-25 valve packing cartridge kits and the YBA-635 valve packing parts kit are used for repair and replacement of the valve packing on current VB-121, -324, and -7xxx valves and discontinued VB-111, -131, -151, -314, -334, -354, and -9xxx valve models.

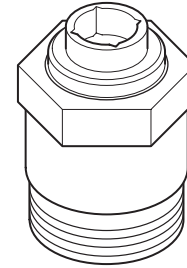

YBA-622-2 Valve Packing Cartridge Kit

Model Chart

Table-1 Available Models.

Part Number	Components Contained in Kit
YBA-622-2 ^a YBA-622-2-0-25 ^b	Valve Cartridge, Packing Assembly for: Current 1/2" to 2" VB-7xxx Discontinued 1/2" to 1-1/4" VB-9xxx ^a , VB-111, VB-121, VB-314, VB-334, VB-354 series Valves
YBA-635	Packing Assembly and Packing Grease for the following discontinued valves: 5/8" O.D. VB-131 series inverted flare 1/2" to 1-1/4" VB-151 series screwed 1/2" VB-922x, VB-9263, VB-9283 series screwed 1-1/2" and 2" VB-9xxx valves series screwed

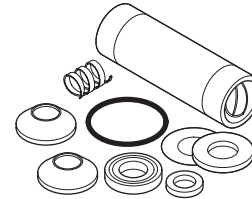

YBA-635 Valve Packing Parts Kit

^a The YBA-622-2 was not designed to be used to repair VB-131, VB-151, 1/2" VB-922x, -9263, or -9283 valves, or 1-1/2" to 2" VB-9xxx valves. Packing-only replacement for these valves requires the YBA-635. For packing and valve stem and plug replacement, use the appropriate RYB-9xx-x valve repair kit. See Barber-Colman Maintenance Parts, F-26033.

^b YBA-622-2-0-25 includes (25) YBA-622-2 packing cartridges and (1) TOOL-20-1 wrench.

Applicable Literature

- Barber-Colman Maintenance Parts, F-26033
- EN-205 Water Systems Guidelines Engineering Information, F-26080

INSTALLATION

Inspection

Inspect the package for damage. If damaged, notify the appropriate carrier immediately. If undamaged, open the package and inspect the device for obvious damage. Return damaged products.

Requirements



- Job wiring diagrams
- Tools:
 - Appropriate screwdrivers and wrenches (not provided)
 - TOOL-20-1, Packing wrench
- Training: Installer must be a qualified technician

Warning: Before the packing nut is removed, isolate the valve body using shutoff valves (if provided in the piping system) or depressurize system to zero (0 psi) gauge at the valve body. Drain fluid from the isolated or depressurized part of the system. If the packing nut is loosened or removed while there is water or steam pressure inside the valve and piping, the valve packing may blow out with potential of bodily injury and/or water or steam damage.

Caution:

- Do not use the YBA-622-2 to repair 1/2" VB-131, VB-151, VB-922x, -9263, or -9283 valves. Packing-only repair for these valves requires the YBA-635. Alternatively, the appropriate RYB valve repair kit may be used to replace both the stem and plug and the packing. Refer to **Barber-Colman Maintenance Parts, F-26033** for valve repair kits.
- Do not exceed the ratings of the device(s).
- Do not apply fluid pressure to the system unless all valve and/or the valve assemblies have been installed.
- Control valve operation should be stable and not hunt at any time. Excessive stroking of the valve stem due to improper system setup can result in premature wear.

Complete Packing and Cartridge Replacement Installation Using YBA-622-2

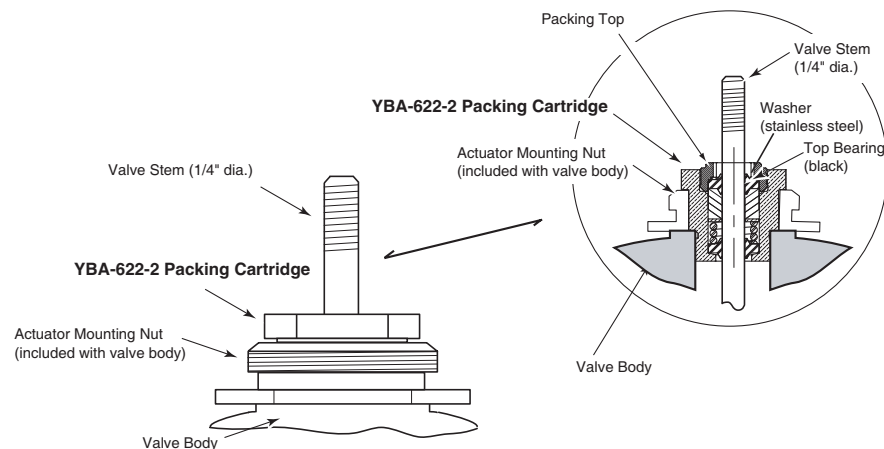

Figure-1 Installation of YBA-622-2 Complete Packing Cartridge into 1/2" to 2" VB-7xxx and 1/2" to 1-1/4" Obsolete VB-9xxx Valves.

Note: If valve stem is worn or scratched, replace the stem and plug assembly in addition to the valve packing cartridge. Consult F-26033 for the appropriate valve repair kit.

1. Once system is depressurized, remove and discard existing cartridge. Retain actuator mounting nut.
2. Slide actuator mounting nut onto new cartridge with threaded portion facing upwards.

Note:

- YBA-622-2 can be distinguished from earlier versions by its stainless steel backup washer and black top bearing (refer to Figure-1).
- Obsolete YBA-622 has a brass thin washer (refer to Figure-2) and white top bearing.
- Obsolete YBA-622-1 has a stainless steel thin washer and white top bearing.

Note: Packing top (see Figure-1) must be threaded **only one turn** into cartridge before sliding over valve stem

3. Apply Teflon pipe sealant (Loctite #592-41 or equivalent) to the bottom threads of the new cartridge. Install YBA-622-2 over valve stem and tighten into valve body, torque to 40 ft-lb (54 Nm).
4. Tighten down packing top securely using TOOL-20-1.

Caution: TOOL-20 cannot be used on YBA-622-1 or YBA-622-2. Attempting to use TOOL-20 may cause damage to the packing assembly. TOOL-20-1 with slotted end **must** be used. TOOL-20-1 can also be used on earlier versions.

YBA-622 Valve Packing Parts Replacement Using YBA-635

Note: Do not attempt to repack YBA-622-1 or YBA-622-2. YBA-635 cannot be used with YBA-622-1 or YBA-622-2. If the existing YBA-622-2 or obsolete YBA-622-1 is unusable, the entire packing must be replaced. Refer to the **Complete Packing and Cartridge Replacement Installation** section.

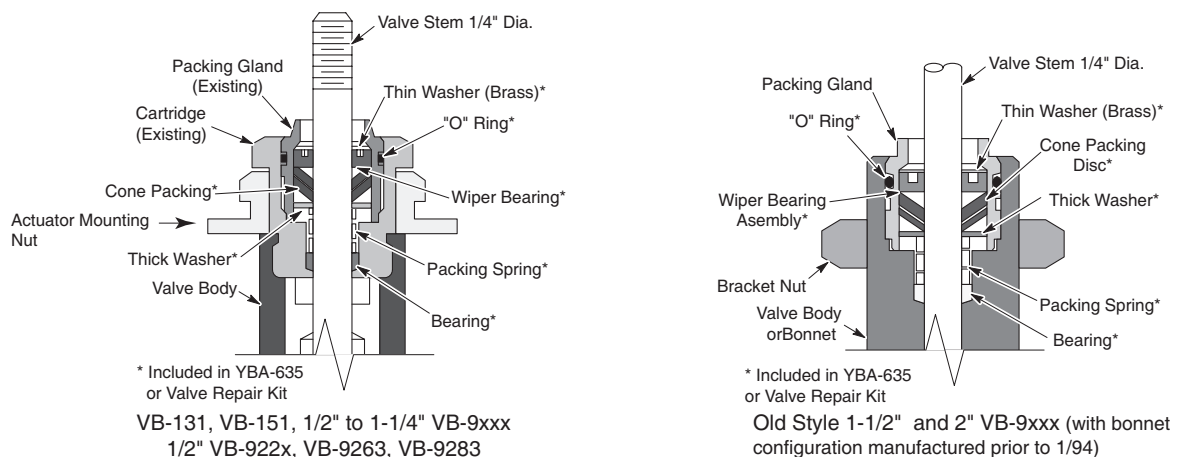

Figure-2 Installation of YBA-635 Packing Parts Kit onto Discontinued Valves

Note: If valve stem is worn or scratched, replace the stem and plug assembly in addition to the valve packing cartridge. Consult F-26033 for the appropriate valve repair kit.

1. Remove existing packing gland with TOOL-20-1. Make sure that the retaining ring is brass and not stainless steel. Salvage existing packing gland (see Figure-2)
2. Remove and discard old packing parts.
3. Clean valve stem, salvaged packing gland, and inside of cartridge.
4. Apply coating of silicone grease from grease packet to the valve stem, salvaged packing gland, and inside cartridge.
5. If applicable, slide actuator mounting nut (see Figure-2) onto valve body with threaded section pointing upwards. Install new packing per above figure.
6. Apply Teflon pipe sealant (Loctite #592-41 or equivalent) to the bottom threads of the packing gland. Install and tighten packing gland with TOOL-20-1.

Caution: Do not overtighten the packing gland.

MAINTENANCE

Durability of valve stems and packing is dependent on maintaining non-damaging water conditions. Inadequate water treatment or filtration can result in corrosion, scaling, or abrasive particle formation. Scale and corrosion products can migrate from pipe walls to control valves resulting in stem and packing scratches, which can adversely affect packing life and other parts of the hydronic system. This condition can be avoided by the use of proper cleaning, treatment chemicals and storage procedures.

To maintain non-damaging conditions, the system should be cleaned prior to start up. Filtration equipment should be used where needed and a regularly scheduled program of water condition monitoring and/or treatment should be maintained.

Follow the advice of a qualified water treatment and control specialist.

For additional detailed information refer to **EN-205, Water System Guidelines Engineering Information, F-26080.**

© Copyright 2004 Invensys Building Systems, Inc. All rights reserved.

Invensys is a trademark of Invensys plc and its subsidiaries and affiliates.

No part of this document may be photocopied or reproduced by any means, or translated to another language without prior written consent of Invensys.

All specifications are nominal and may change as design improvements are introduced. Invensys shall not be liable for damages resulting from misapplication or misuse of its products.