



Invensys Building Systems
1354 Clifford Avenue (Zip 61111)
P.O. Box 2940
Loves Park, IL 61132-2940
United States of America

VB-9313 Series

**2-1/2" and 3" Screwed NPT
2-1/2" to 6" 125 Lb. Flanged
Three-Way Mixing Valves
General Instructions**

Application

VB-9313 series three-way mixing valves control hot or chilled water in heating or air conditioning systems. These valves must be piped with two inlets ("A" and "B" ports) and one outlet ("AB" port). They are used for two-position or proportional control applications. Valve assemblies require an actuator and a valve linkage that must be purchased separately.



▼ DANGER

Do not use for combustible gas applications. The VB-9313 series valve packings are not rated for combustible gas applications, and if used in these applications, gas leaks and explosions will result.

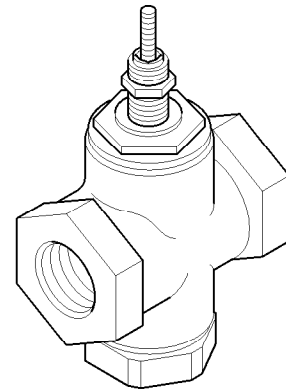

Typical of VB-9313-0-4-P
2-1/2" and 3"

Features

- Valve sizes 2-1/2" to 6".
- 250 psig pressure rating per ANSI Standards (B16.15–1985) for screwed cast bronze bodies.
- 125 psig pressure rating per ANSI Standards (B16.1–1993) for flanged cast iron bodies.
- Spring-loaded TFE packing.

Applicable Literature

- Siebe Environmental Controls Catalog, F-25683
- Siebe Environmental Controls Cross-Reference Guide, F-23638
- Siebe Environmental Controls Reference Manual, F-21683
- Siebe Environmental Controls Application Manual, F-21335
- Siebe Environmental Controls Valve Selection Guide, F-26094
- Control Valve Sizing, F-13755
- Valve Selection Chart for Water, F-11080
- EN-205 Water System Guidelines, F-26080

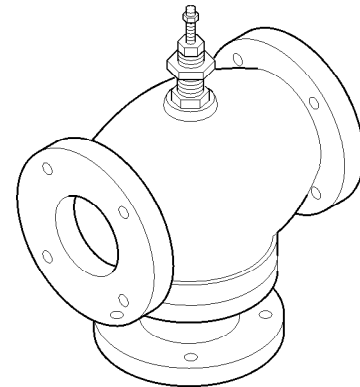

Typical of VB-9313-0-5-P
2-1/2" to 6"

SPECIFICATIONS

Table-1 Specifications/Models.

Specifications			Valve Body Series VB-9313-0-4-P	Valve Body Series VB-9313-0-5-P
Service			Chilled or Hot Water	
Flow Characteristics (Figure-1)			Mixing	
Sizes			2-1/2" and 3"	2-1/2" to 6"
Type of End Fitting			Screwed NPT	125 lb. Flanged
Valve Materials	Body		Bronze	Iron
	Seat		Bronze	
	Stem		Stainless Steel	
	Plug		Brass	
	Packing		Spring-loaded TFE	
	Disc		None	
ANSI Pressure Class (Figure-2)			250 (up to 400 psig below 150°F)	125 lb. Flanged (up to 200 psig below 150°F)
Allowable Control Media Temperature			40 to 300°F (4 to 149°C)	
Allowable Differential Pressure for Water*			35 psi (241 kPa) Max. for Normal Life (refer to d ⁴ "Cavitation Limitations on Valve Pressure Drop" on page 6)	
Valve Size	C _v Rating	k _{vs} Rating**	Complete Valve Body Part Number	
2-1/2"	67	58	VB-9313-0-4-12	Not Available
	74	64	Not Available	VB-9313-0-5-12
3"	91	79	VB-9313-0-4-13	Not Available
	101	87	Not Available	VB-9313-0-5-13
4"	170	147		VB-9313-0-5-14
5"	290	251		VB-9313-0-5-15
6"	390	337		VB-9313-0-5-16

*Maximum recommended differential pressure in open position. Do not exceed recommended differential pressure (pressure drop) or integrity of parts may be affected. Exceeding maximum recommended differential pressure voids product warranty.

$$**k_{vs} = m^3/h (\Delta P = 100 \text{ kPa}) \quad C_v = k_{vs} \times 1.156$$

Close-off Pressure Rating

The close-off pressure rating is dependent on the size of the valve, valve linkage, and actuator. Consult the appropriate valve linkage general instruction sheet for the close-off ratings.

Spring Return Position of Valve Assembly

For a valve assembly (valve, linkage, and actuator) to have a spring return position, the actuator must be of the spring return type. See Table-2 for spring return position of valve assemblies.

Table-2 Required Compatible Actuators/Linkages.

Actuator Series	Required Valve Linkage		Spring Return Position*
	2-1/2" to 4" Valves	5" & 6" Valves	
MA-318, MA-418, MA-419	AV-395	—	Stem Up or Down
MC-351, MC-431, MC-4311, MC5-4311	AV-396 or AV-352	AV-352	None
MF-63103, MF-63123	AV-672	—	
MK-6801, MK-6811, MK-6821	AV-495		
MK-8801, MK-8811, MK-8821	AV-496		
MK-8901, MK-8911, MK-8921	—		AV-496
MM-400, MMR-400	AV-630 or AV-630-30	—	None
MM-500, MMR-500			Stem Up or Down
MP-361, MP-461-600, MP-465, MP5-4651	AV-395		Stem Down
MP-371, MP-471-600, MP-475, MP5-4751			Stem Up
MP-381, MP-382, MP-481-600, MP-485, MP-486, MP-4851, MP5-4851	AV-396 or AV-352		AV-352
MP-9713, MP-9750	AV-357 (4" only)	AV-357	
MP-9810	—	AV-358	

*Stem Up = Flow port "B" to port "AB". Stem Down = Flow port "A" to port "AB."

Flow Characteristics

Three-way mixing valves are designed so that the flow from either of the inlet ports to the outlet is approximately linear, which means the total flow from the outlet is almost constant over the stroke of the valve stem. See Figure-1 for typical flow characteristics of VB-9313 series valve bodies.

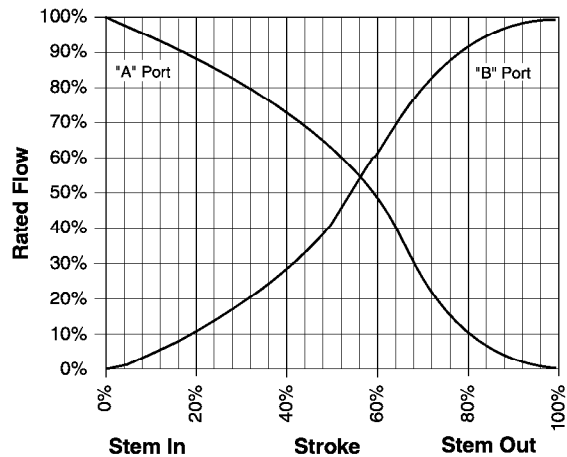

Figure-1 Typical Flow Characteristics.

Rangeability

Rangeability is the ratio of rated flow to the minimum controllable flow through a valve. For mixing valves, control begins as soon as plug displacement allows flow. Thus, three-way valve rangeability normally exceeds 500:1, which is the reciprocal of 0.2% nominal leakage.

Temperature/Pressure Ratings

See Figure-2 for temperature and pressure ratings. Consult the appropriate valve linkage general instruction sheet for the effect of valve body ambient temperatures on specific actuators. Ratings conform with published values and disclaimer.

VB-9313-0-4-P (Screwed Cast Bronze Body)

Standards: ANSI B16.15-1985

Materials: ASTM B584-93b: UNS C83450, UNS C83600, or UNS C84400

VB-9313-0-5-P (Flanged Cast Iron Body)

Standards: ANSI B16.1-1993

Materials: ASTM A126-93 Class B

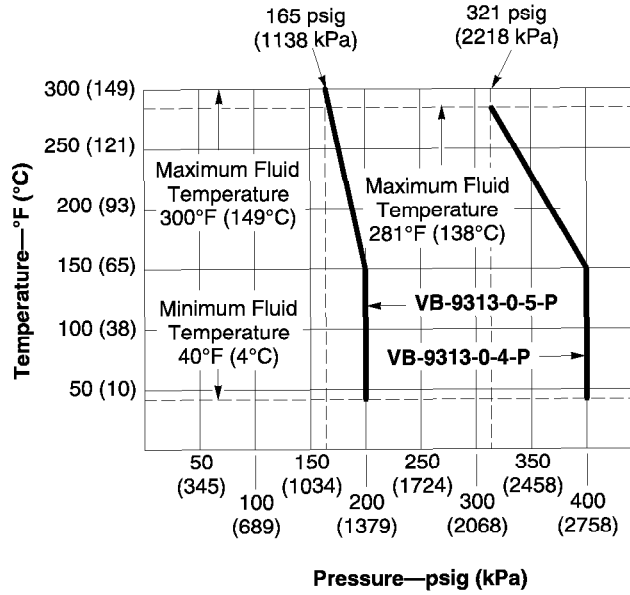

Figure-2 Temperature and Pressure Ratings for VB-9313 Series Valve Bodies.

VALVE SIZING AND SELECTION

Water

Two-position

Two-position control valves are normally selected “line size” to keep pressure drop at a minimum. If it is desirable to reduce the valve below line size, then 10% of “available pressure” (that is, the pump pressure differential available between supply and return mains with design flow at the valve location) is normally used to select the valve.

Proportional to Bypass Flow

Proportional mixing valves used to bypass flow (Figure-6) are piped on the outlet side of the load to throttle the water flow through the load and therefore control heat output of the load. These valves are usually selected to take a pressure drop equal to at least 50% of the “available pressure.” As “available pressure” is often difficult to calculate, the normal procedure is to select the valve using a pressure drop at least equal to the drop in the coil or other load being controlled (except where small booster pumps are used) with a minimum recommended pressure drop of 5 psi (34 kPa). When the design temperature drop is less than 60°F (33°C) for conventional heating systems, higher pressure drops across the valve are needed for good results (Table-3).

Table-3 Conventional Heating System.

Design Temperature Load Drop °F (°C)	Recommended Pressure Drop* (% of Available Pressure)	Multiplier on Load Drop
60 (33) or More	50%	1 x Load Drop
40 (22)	66%	2 x Load Drop
20 (11)	75%	3 x Load Drop

*Recommended minimum pressure drop = 5 psi (34 kPa).

Secondary Circuits with Small Booster Pumps: 50% of available pressure difference (equal to the drop through load, or 50% of booster pump head).

Proportional to Blend Water Flows

Proportional valves used to blend two water flows (Figure-7 and Figure-8) control the heat output by varying the water temperature to the load at constant flow. These valves do not require high pressure drops for good control results. They can be sized for a pressure drop of 20% of the “available pressure” or equal to 25% of the pressure drop through the load at full flow.

Water Table

See Table-4 for water capacity of VB-9313 series valves.

Table-4 Water Capacity in Gallons Per Minute for VB-9313 Series.

Valve Body Part Number	C _v Rating	Differential Pressure (ΔP in psi)														
		1	2	3	4	5	6	7	8	9	10	15	20	25	30	35
VB-9313-0-4-12	67	67	95	116	134	150	164	177	190	201	212	259	300	335	367	396
VB-9313-0-5-12	74	74	105	128	148	165	181	196	209	222	234	287	331	370	405	438
VB-9313-0-4-13	91	91	129	158	182	203	223	241	257	273	288	352	407	455	498	538
VB-9313-0-5-13	101	101	143	175	202	226	247	267	286	303	319	391	452	505	553	598
VB-9313-0-5-14	170	170	240	294	340	380	416	450	481	510	538	658	760	850	931	1006
VB-9313-0-5-15	290	290	410	502	580	648	710	767	820	870	917	1123	1297	1450	1588	1716
VB-9313-0-5-16	390	390	552	675	780	872	955	1032	1103	1170	1233	1510	1744	1950	2136	2307

C_v Equation

$$C_v = \frac{\text{GPM}}{\sqrt{\Delta P}} \quad \Delta P = \left(\frac{\text{GPM}}{C_v} \right)^2 \quad \text{GPM} = C_v \sqrt{\Delta P}$$

Where:

C_v = Coefficient of flow

GPM = U.S. gallons per minute (60°F, 15.6°C)

ΔP = Differential pressure in psi (pressure drop)

Cavitation Limitations on Valve Pressure Drop

A valve selected with too high a pressure drop can cause erosion of discs and/or wire drawing of the seat. In addition, cavitation can cause noise, damage to the valve trim (and possibly the body), and choke the flow through the valve.

Do not exceed the maximum differential pressure (pressure drop) for the valve selected.

The following formula can be used on higher temperature water systems, where cavitation could be a problem, to estimate the maximum allowable pressure drop across the valve:

$$P_m = 0.5 (P_1 - P_v)$$

Where:

P_m = Maximum allowable pressure drop

P_1 = Absolute inlet pressure (psia)

P_v = Absolute vapor pressure (refer to Table-5)

NOTE

Add 14.7 psi to gauge supply pressure to obtain absolute pressure value.

For example, if a valve is controlling 200°F water at an inlet pressure of 18 psig, the maximum pressure drop allowable would be:

$$P_m = 0.5 [(18 + 14.7) - 11.53] = 10.6 \text{ psi}$$

(Vapor pressure of 200°F water is 11.53 psi.)

If the pressure drop for this valve is less than 10.6 psi, cavitation should not be a problem.

Systems where cavitation is shown to be a problem can sometimes be redesigned to provide lower inlet velocities. Valves having harder seat materials should be furnished if inlet velocities cannot be lowered.

Table-5 Vapor Pressure of Water Table.

Water Temp. (°F)	Vapor Pressure (psig)	Water Temp. (°F)	Vapor Pressure (psig)	Water Temp. (°F)	Vapor Pressure (psig)	Water Temp. (°F)	Vapor Pressure (psig)
40	0.12	90	0.70	140	2.89	190	9.34
50	0.18	100	0.95	150	3.72	200	11.53
60	0.26	110	1.28	160	4.74	210	14.12
70	0.36	120	1.69	170	5.99	220	17.19
80	0.51	130	2.22	180	7.51	230	20.78

Additional Valve Sizing Information

For additional valve sizing information, see:

- CA-28 Control Valve Sizing, F-13755
- Valve Selection Chart Water, F-11080
- Valve Sizing Slide Rule, TOOL-150

INSTALLATION

Inspection

Inspect the package for damage. If damaged, notify the appropriate carrier immediately. If undamaged, open the package and inspect the device for obvious damage. Return damaged products.

Requirements

- Tools (not provided): Pipe wrenches
- Training: Installer must be a qualified, experienced technician
- Appropriate accessories

▼ CAUTION

- Install the valve with the flow in the direction of the flow arrows ("A" and "B" ports are inlets and "AB" port is the outlet).
- Do not exceed the ratings of the device.
- Avoid locations where excessive moisture, corrosive fumes, or vibration are present.

Mounting

1. The valve should be mounted in a weather-protected area in a location that is within the ambient limits of the actuator. When selecting a location, allow sufficient room for valve linkage, actuator, and other accessories and for service of the product.
2. The preferred mounting position for the valve is with the valve stem vertical above the valve body. Avoid mounting the valve so that the valve stem is below horizontal.
3. The valves must be piped with two inlets ("A" and "B" ports) and one outlet ("AB" port).

Screwed Valve Bodies

The VB-9313-0-4-P series screwed valve bodies conform to American Standard Taper Pipe Threads (NPT).

1. Apply pipe dope sparingly to all but the last two threads of a properly threaded, reamed, and cleaned pipe. Make sure that pipe chips, scale, etc. do not get into the pipe since this material may lodge in the valve seat and prevent proper closing and opening of the valve.
2. Start the joint by hand screwing the pipe into the valve. If the thread engagement feels "right," turn the pipe by hand as far as it will go.
3. Use a pipe wrench to fully tighten the valve to the pipe. Do not over tighten or strip threads. See Table-6 and Figure-3 for the normal engagement length of the threads. Figure-4 shows a means of tightening the pipe so that the valve is not twisted or crushed.

Table-6 Normal Thread Engagement Between Male Pipe Thread and Valve Body.

Valve Size Inches (NPT)	Normal Engagement	Valve Size Inches (NPT)	Normal Engagement
2-1/2"	15/16"	3"	1"

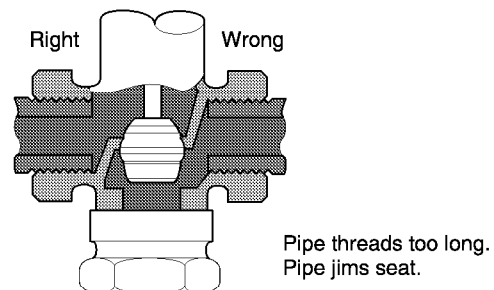

Figure-3 Normal Thread Engagement.

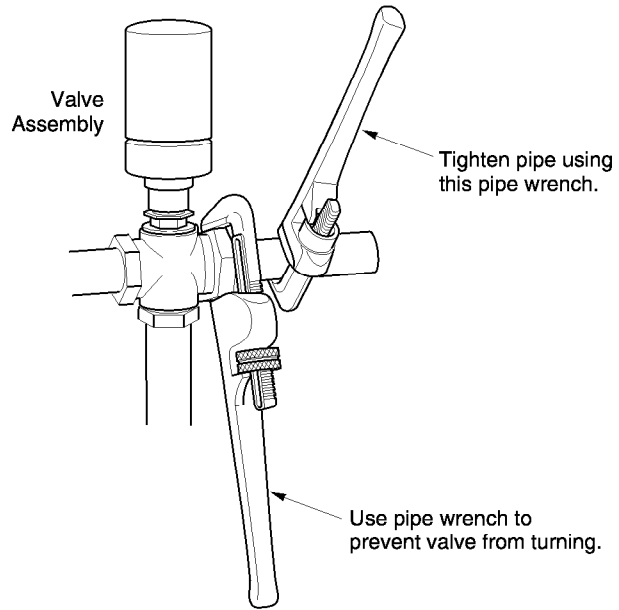

Figure-4 Installation of Screwed End Valves.

Flanged Valve Bodies

The VB-9313-0-5-P series flanged valve bodies conform to American Standard 125 Lb. Cast Iron Pipe Flanges. The companion flanges (not provided) should be the same specification as the valve. The 125 lb. flanges have plain flat faces and should not be bolted to a raised faced flange.

1. All parts should be clean to assure the best results.
2. The pipe with the companion flanges installed should be properly supported and aligned. Be sure the companion flange is flush with the face of the valve body flange and lined up squarely.
3. Use a gasket material (not provided) that is recommended for the medium being handled.

▼ CAUTION

Do not apply pipe dope to the valve flange, gasket, or companion flange.

4. See Figure-5 for flange and flange bolt details. Figure-5 also shows the proper way a flanged valve should be mounted.

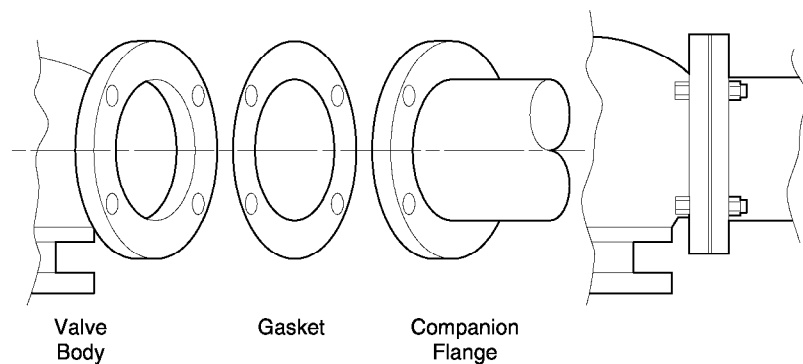

Figure-5 Installation of Flanged End Valves.

TYPICAL PIPING

All piping must comply with local codes and ordinances. Refer to Figure-6 through Figure-8 for typical piping.

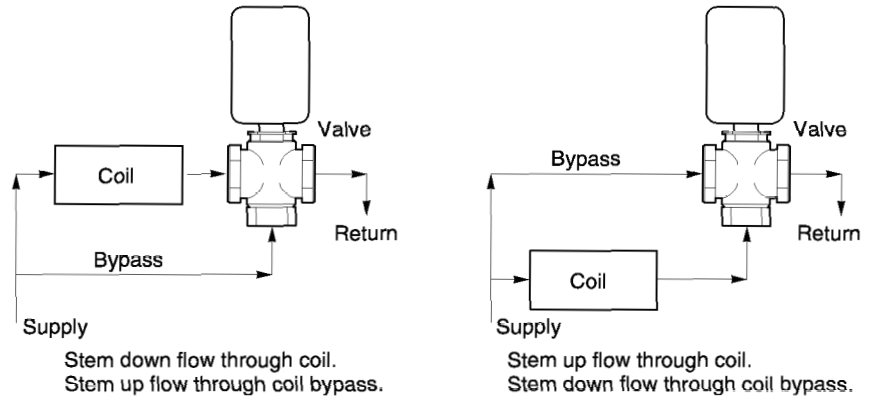

Figure-6 Typical Piping for Control of Heating or Cooling Coil.

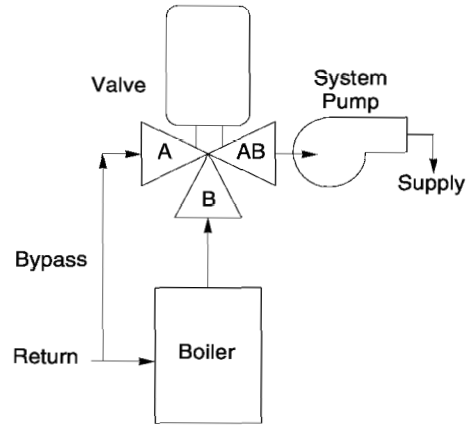

Figure-7 Typical Boiler Hot Water Reset.

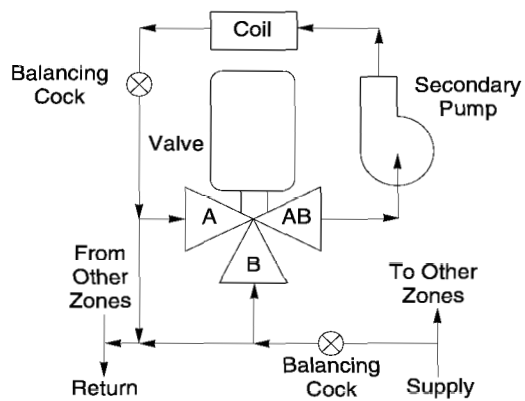

Figure-8 Typical Primary-Secondary Piping.

CHECKOUT

1. Make sure the valve stem operates freely before installing the valve linkage and the actuator.
2. If the stem does not operate freely, it may indicate that the valve was twisted or crushed during installation or that the stem was bent by rough handling. These conditions may require that the valve be replaced.
3. After the piping is under pressure, check the valve body and the connections for leaks.
4. After the valve linkage and the actuator are installed, check their operation.
 - a. Drive the actuator and run the valve to the stem down position. Make sure the linkage and valve stem move freely. At the stem down position, the valve should shut off the "B" port.
 - b. Drive the actuator and valve to the stem up position. Again, the valve stem and linkage should operate smoothly. At the stem up position, the valve should shut off the "A" port.

MAINTENANCE

Regular maintenance of the total system is recommended to assure sustained performance. See Table-7 for maintenance kit part numbers.

Table-7 Maintenance Kits for VB-9313 Valves.

Valve Body Part Number	Replacement Packing Assembly	Valve Repair Kit*
VB-9313-0-4-12	YBA-651-1	RYB-931-12
VB-9313-0-4-13		RYB-931-13
VB-9313-0-5-12		RYB-931-12
VB-9313-0-5-13		RYB-931-13
VB-9313-0-5-14		RYB-931-14
VB-9313-0-5-15		RYB-931-15
VB-9313-0-5-16		RYB-931-16

*Kit includes replacement packing and stem & plug assembly.

Water System Maintenance

All heating and cooling systems are susceptible to valve and system problems caused by improper water treatment and system storage procedures. These guidelines are provided to help avoid valve and water system problems resulting from improperly treated water or storage procedures in cooling and hot water systems, and to obtain maximum life from Siebe Environmental Controls valves.

Durability of valve stems and packings is dependent on maintaining non-damaging water conditions. Inadequate water treatment or filtration, not in accordance with chemical supplier/ASHRAE handbook recommendations, can result in corrosion, scale, and abrasive particle formation. Scale and particulates can result in stem and packing scratches and can adversely affect packing life and other parts of the hydronic system.

To maintain non-damaging conditions, follow these guidelines:

- Clean the system prior to start up. Use a nitrite or molybdate-based treatment program.
- Use filtration equipment where needed.
- Properly store off-line systems and monitor water treatment results using corrosion test coupons.
- Follow the advice of a water treatment professional.
- Consult EN-205 for further details.

DIMENSIONAL DATA

Table-8 Dimensions for VB-9313 Series Valves (Figure-9 and Figure-10).

Part Number	Valve Size	Dimensions in Inches (mm)					
		A	B	C	D (Stem Down)	E (Stroke)	F
VB-9313-0-4-12	2-1/2"	8-1/2 (216)	4-5/8 (118)	4-1/4 (108)	1-5/8 (41)	7/8 (22)	3-7/8 (98)
VB-9313-0-4-13	3"	9-1/2 (241)	5 (127)	4-3/4 (121)			4-5/8 (118)
VB-9313-0-5-12	2-1/2"	8-1/2 (216)	5-3/8 (137)	3-1/2 (89)			7 (178)
VB-9313-0-5-13	3"	9-1/2 (241)	6-3/8 (162)	3-3/4 (95)		7-1/2 (191)	
VB-9313-0-5-14	4"	11-1/2 (292)	8-1/2 (216)	4-1/2 (114)		9 (229)	
VB-9313-0-5-15	5"	13 (330)	8-3/4 (222)	5 (127)		1-3/4 (45)	10-1/8 (257)
VB-9313-0-5-16	6"	14 (356)	9-3/4 (248)	5-7/8 (149)	11 (279)		

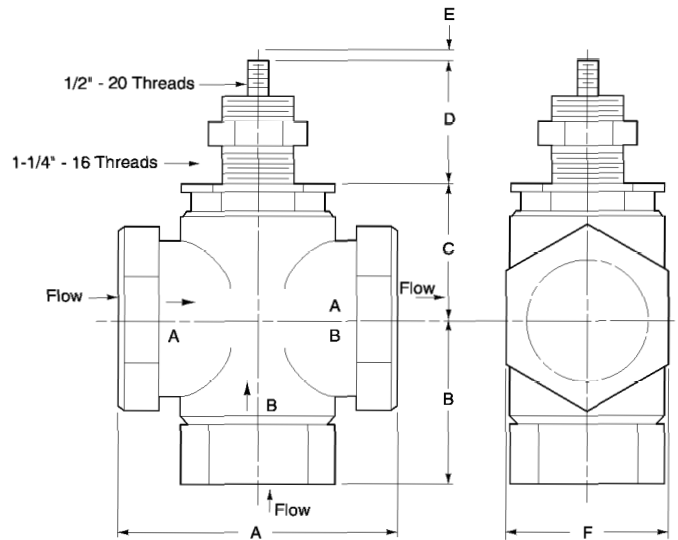

Figure-9 Typical of VB-9313-0-4-P, 2-1/2" and 3" Valve Bodies.

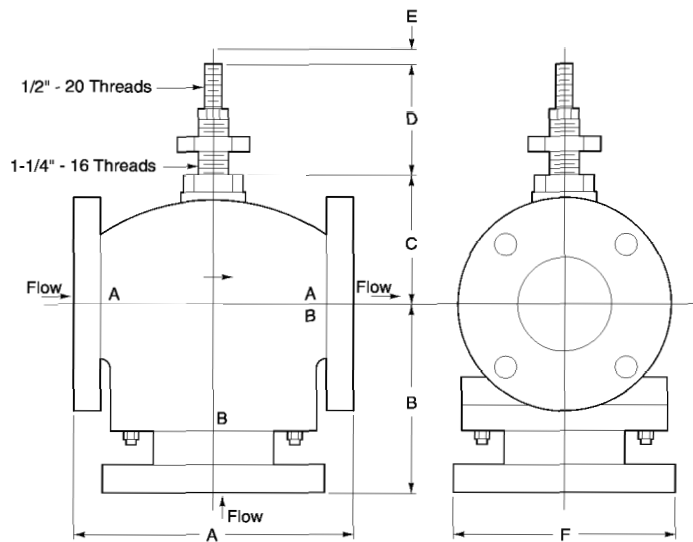

Figure-10 Typical of VB-9313-0-5-P, 2-1/2" to 6" Valve Bodies.

**Table-9 Flange Detail for American Standard 125 lb. Cast Iron Pipe Flanges.
(Figure-11).**

Nominal Pipe Size	Flanges		Drilling		Bolting		Length of Machine Bolts E
	Flange Diameter	Flange Thickness	Diameter of Bolt Circle C	Diameter of Bolt Holes D	Number of Bolts	Diameter of Bolts	
	A	B					
2-1/2"	7"	11/16"	5-1/2"	3/4"	4	5/8"	2-1/2"
3"	7-1/2"	3/4"	6"				
4"	9"	15/16"	7-1/2"	7/8"	8	3/4"	3"
5"	10"		8-1/2"				
6"	11"	1"	9-1/2"				

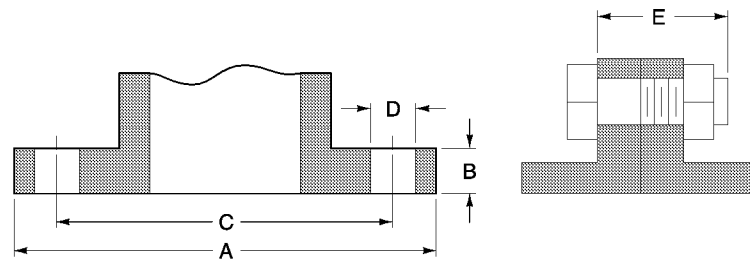

Figure-11 Flange Dimensions.