



Invensys Building Systems  
1354 Clifford Avenue (Zip 61111)  
P.O. Box 2940  
Loves Park, IL 61132-2940  
United States of America

A Siebe Group Company

## VB-7315 Series

### 15 mm to 50 mm Screwed Rp Three-Way Mixing Valves General Instructions

## Application

VB-7315 series three-way mixing valves control hot or chilled water in heating or air conditioning systems. These valves must be piped with two inlets ("A" and "B" ports) and one outlet ("AB" port). They are used for two-position or proportional control applications. Valve assemblies require an actuator and a valve linkage that must be purchased separately.



**Danger:** Do not use for combustible gas applications. The VB-7315 series valve packings are not rated for combustible gas applications, and if used in these applications, gas leaks and explosions could result.

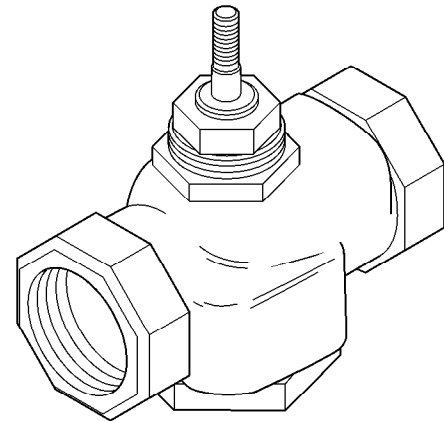

## Features

- Valve sizes 15 mm to 50 mm
- PN16 nominal pressure; also meets 250 psig pressure rating per ANSI Standards (B16.15–1985) for screwed cast bronze bodies
- Spring-loaded TFE packing
- End fittings Internal Parallel Pipe Thread per ISO 7/1, BS 21, JIS B0203

## Applicable Literature

- Siebe Environmental Controls Catalog, F-25683
- Siebe Environmental Controls Cross-Reference Guide, F-23638
- Siebe Environmental Controls Reference Manual, F-21683
- Siebe Environmental Controls Application Manual, F-21335
- Control Valve Sizing, F-13755
- Valve Selection Chart for Water, F-11080
- EN-205 Water System Guidelines, F-26080

# SPECIFICATIONS

**Table-1 Specifications/Models.**

Specifications		Valve Body Series VB-7315-0-4-P
<b>Service</b>		Chilled or Hot Water
<b>Flow Characteristics (Figure-1)</b>		Mixing
<b>Sizes</b>		15 mm to 50 mm
<b>Type of End Fitting</b>		Internal Parallel Pipe Thread per ISO 7/1, BS 21, JIS B0203
<b>Valve Materials</b>	<b>Body</b>	Bronze
	<b>Seat</b>	Bronze
	<b>Stem</b>	Stainless Steel
	<b>Plug</b>	Brass
	<b>Packing</b>	Spring-loaded TFE
	<b>Disc</b>	None
<b>Pressure Class</b>		PN16 (16 Bar) <sup>a</sup>
<b>Allowable Control Media Temperature</b>		-7 to 138°C
<b>Allowable Differential Pressure for Water<sup>b</sup></b>		241 kPa Max. for Normal Life (refer to "Cavitation Limitations on Valve Pressure Drop" on page 6)
<b>Valve Size in mm (R<sub>p</sub>)<sup>c</sup></b>	<b>k<sub>vs</sub> Rating<sup>d</sup></b>	<b>Complete Valve Body Part Number</b>
15 (1/2)	1.9	<b>VB-7315-0-4-2</b>
	3.8	<b>VB-7315-0-4-4</b>
20 (3/4)	6.5	<b>VB-7315-0-4-6</b>
25 (1)	12	<b>VB-7315-0-4-8</b>
32 (1-1/4)	17	<b>VB-7315-0-4-9</b>
40 (1-1/2)	24	<b>VB-7315-0-4-10</b>
50 (2)	35	<b>VB-7315-0-4-11</b>

<sup>a</sup> Also meets ANSI Class 250 (Figure-2)

<sup>b</sup> Maximum recommended differential pressure. Do not exceed recommended differential pressure (pressure drop) or integrity of parts may be affected. Exceeding maximum recommended differential pressure voids product warranty.

<sup>c</sup> R<sub>p</sub> = internal parallel pipe thread

<sup>d</sup> k<sub>vs</sub> = m<sup>3</sup>/h (ΔP = 100 kPa)      C<sub>v</sub> = k<sub>vs</sub> × 1.156

## Close-off Pressure Rating

The close-off pressure rating is dependent on the size of the valve, valve linkage, and actuator. Consult the **Siebe Environmental Controls Catalog, F-25683**, for close-off ratings.

## Spring Return Position of Valve Assembly

For a valve assembly (valve, linkage, and actuator) to have a normal (spring return) position, the actuator must be of the spring return type. See Table-2 for spring return position of valve assemblies.

**Table-2 Required Compatible Actuators/Linkages.**

Actuator Series	Required Valve Linkage	Spring Return Position <sup>a</sup>
MA-318, MA-418, MA-419	AV-391	Stem Up or Down
MA-5210, MA-5211, MA-5213	AV-7600 <sup>b</sup>	Stem Up
MC-351, MC-431, MC-4311, MC5-4311	AV-393	None
MF-5413, MF-5513	AV-7600 & AV-601	Stem Up
MF-22203, MF-22303, MF-22323	Included w/Actuator	None
MF-63103, MF-63123		
MK-2690	AV-7400	Stem Up
MK-4601, MK-4611, MK-4621	AV-401	
MK-6601, MK-6611, MK-6621	AV-430	
MM-400, MMR-400	AV-630 or AV-630-10	None
MM-500, MMR-500		Stem Up or Down
MP-361, MP-461-600, MP-465, MP5-361, MP5-4651	AV-391	Stem Down
MP-371, MP-471-600, MP-475, MP5-371, MP5-4751		Stem Up
MP-381, MP-382, MP-481-600, MP-485, MP-486, MP-4851, MP5-4851	AV-393	None
MP-5210, MP-5211, MP-5213	AV-7600 <sup>b</sup>	Stem Up
MP-5410, MP-5411, MP-5413	AV-7600 & AV-601	
MP-5511, MP-5513		
MPR-5610, MPR-5611, MPR-5613	AV-7600 & AV-601	Stem Up
MPR-5713		
MS-22353	Included w/Actuator	None

<sup>a</sup> Stem Up = Flow port "B" to port "AB". Stem Down = Flow port "A" to port "AB."

<sup>b</sup> High ambient temperatures with high media temperatures in the valve may require the use of AV-601 in addition to AV-7600. See General Instructions for AV-7600 (F-26235) and AV-601 (F-19069) for details.

## Flow Characteristics

Three-way mixing valves are designed so that the flow from either of the inlet ports to the outlet is approximately linear, which means the total flow from the outlet is almost constant over the stroke of the valve stem. See Figure-1 for typical flow characteristics of VB-7315 series valve bodies.

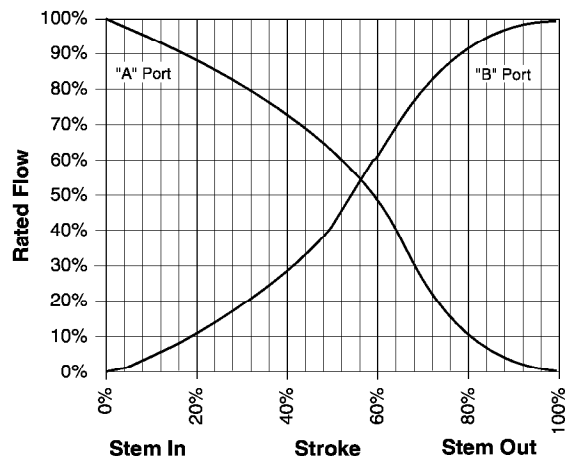

Figure-1 Typical Flow Characteristics.

## Rangeability

Rangeability is the ratio of rated flow to the minimum controllable flow through a valve. For mixing valves, control begins as soon as plug displacement allows flow. Thus, three-way valve rangeability normally exceeds 500:1, which is the reciprocal of 0.2% nominal leakage.

## Temperature/Pressure Ratings

See Figure-2 for temperature and pressure ratings. Consult the appropriate valve linkage general instruction sheet for the effect of valve body ambient temperatures on specific actuators. Ratings conform with published values and disclaimer.

### VB-7315-0-4-P (Screwed Cast Bronze Body)

*Standards:* Pressure to ANSI B16.15 Class 250 with 2758 kPa up to 65°C decreasing to 2218 kPa at 138°C

*Materials:* Bronze, ASTM B584

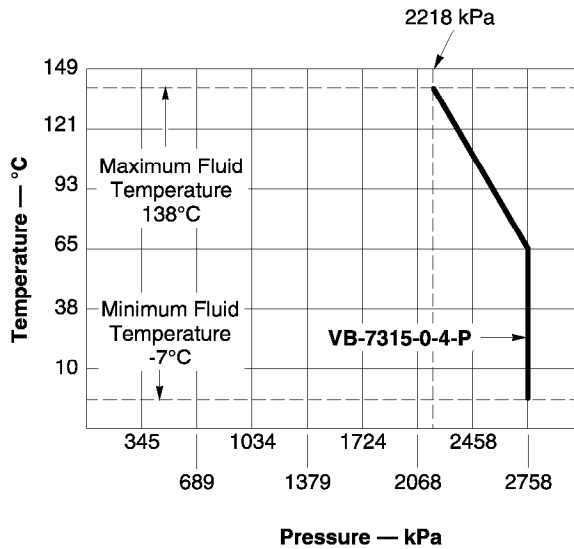

Figure-2 Temperature and Pressure Ratings for VB-7315 Series Valve Bodies.

# VALVE SIZING AND SELECTION

## Water

### Two-position

Two-position control valves are normally selected “line size” to keep pressure drop at a minimum. If it is desirable to reduce the valve below line size, then 10% of “available pressure” (that is, the pump pressure differential available between supply and return mains with design flow at the valve location) is normally used to select the valve.

### Proportional to Bypass Flow

Proportional valves used to bypass flow (Figure-5) are piped on the outlet side of the load to throttle the water flow through the load and therefore control heat output of the load. These valves are usually selected to take a pressure drop equal to at least 50% of the “available pressure.” As “available pressure” is often difficult to calculate, the normal procedure is to select the valve using a pressure drop at least equal to the drop in the coil or other load being controlled (except where small booster pumps are used) with a minimum recommended pressure drop of 34 kPa. When the design temperature drop is less than 33°C for conventional heating systems, higher pressure drops across the valve are needed for good results (Table-3).

**Table-3 Conventional Heating System.**

Design Temperature Load Drop (°C)	Recommended Pressure Drop <sup>a</sup> (% of Available Pressure)	Multiplier on Load Drop
33 or More	50%	1 x Load Drop
22	66%	2 x Load Drop
11	75%	3 x Load Drop

<sup>a</sup> Recommended minimum pressure drop = 34 kPa.

**Secondary Circuits with Small Booster Pumps:** 50% of available pressure difference (equal to the drop through load, or 50% of booster pump head).

### Proportional to Blend Water Flows

Proportional valves used to blend two water flows (Figure-6 and Figure-7) control the heat output by varying the water temperature to the load at constant flow. These valves do not require high pressure drops for good control results. They can be sized for a pressure drop of 20% of the “available pressure” or equal to 25% of the pressure drop through the load at full flow.

### Water Capacity

See Table-4 for water capacity of VB-7315 series valves.

**Table-4 Water Capacity in Litres Per Second (L/s) for VB-7315 Series.**

Valve Body Part Number	k <sub>vs</sub> Rating	Differential Pressure (ΔP in kPa) <sup>a</sup>												
		10	20	30	40	50	60	70	80	90	100	150	200	241
VB-7315-0-4-2	1.9	0.17	0.24	0.29	0.33	0.37	0.41	0.44	0.47	0.50	0.53	0.65	0.75	0.82
VB-7315-0-4-4	3.8	0.33	0.47	0.58	0.67	0.75	0.82	0.88	0.94	1.0	1.1	1.3	1.5	1.6
VB-7315-0-4-6	6.5	0.57	0.81	0.99	1.1	1.3	1.4	1.5	1.6	1.7	1.8	2.2	2.6	2.8
VB-7315-0-4-8	12	1.1	1.5	1.8	2.1	2.4	2.6	2.8	3.0	3.2	3.3	4.1	4.7	5.2
VB-7315-0-4-9	17	1.5	2.1	2.6	3.0	3.3	3.7	4.0	4.2	4.5	4.7	5.8	6.7	7.3
VB-7315-0-4-10	24	2.1	3.0	3.7	4.2	4.7	5.2	5.6	6.0	6.3	6.7	8.2	9.4	10
VB-7315-0-4-11	35	3.1	4.3	5.3	6.1	6.9	7.5	8.1	8.7	9.2	9.7	12	14	15

<sup>a</sup> Bar = kPa/100    kg/cm<sup>2</sup> = kPa x 0.01019    m<sup>3</sup>/h = L/s x (3600/1000)

### k<sub>vs</sub> Equation

$$Q = k_{vs} \cdot \sqrt{\Delta P} \quad \Delta P = \left( \frac{Q}{k_{vs}} \right)^2 \quad k_{vs} = \frac{Q}{\sqrt{\Delta P}}$$

Where:

Q = Flow in cubic metres per hour (m<sup>3</sup>/h)

k<sub>vs</sub> = Flow in cubic metres per hour at a 1 Bar (100 kPa) pressure drop (ΔP)

ΔP = Differential pressure in Bar (pressure drop)

## Cavitation Limitations on Valve Pressure Drop

A valve selected with too high a pressure drop can cause erosion of discs and/or wire drawing of the seat. In addition, cavitation can cause noise, damage to the valve trim (and possibly the body), and choke the flow through the valve.

Do not exceed the maximum differential pressure (pressure drop) for the valve selected.

The following formula can be used on higher temperature water systems, where cavitation could be a problem, to estimate the maximum allowable pressure drop across the valve:

$$P_m = 0.5 (P_1 - P_v)$$

Where:

$P_m$  = Maximum allowable pressure drop (kPa)

$P_1$  = Absolute inlet pressure (kPa)

$P_v$  = Absolute vapor pressure (refer to Table-5)

---

*Note:* Add 101.3 kPa to gauge supply pressure to obtain absolute pressure value.

---

For example, if a valve is controlling 94°C water at an inlet pressure of 125 kPa, the maximum pressure drop allowable would be:

$$P_m = 0.5 [(125 + 101.3) - 81] = 72 \text{ kPa}$$

(Vapor pressure of 94°C water is 81 kPa.)

If the pressure drop for this valve is less than 72 kPa, cavitation should not be a problem.

Systems where cavitation is shown to be a problem can sometimes be redesigned to provide lower inlet velocities. Valves having harder seat materials should be furnished if inlet velocities cannot be lowered.

**Table-5 Vapor Pressure of Water Table.**

Water Temp. (°C)	Vapor Pressure (kPa)	Water Temp. (°C)	Vapor Pressure (kPa)	Water Temp. (°C)	Vapor Pressure (kPa)	Water Temp. (°C)	Vapor Pressure (kPa)
4	0.81	34	5.3	64	24	94	81
10	1.2	40	7.4	70	31	100	101
16	1.8	46	10	76	40	106	125
22	2.6	52	14	82	51	112	153
28	3.8	58	18	88	65	116	175

## Additional Valve Sizing Information

For additional valve sizing information, see:

- CA-28 Control Valve Sizing, F-13755
- Valve Selection Chart Water, F-11080
- Valve Sizing Slide Rule, TOOL-150

# INSTALLATION

## Inspection

Inspect the package for damage. If damaged, notify the appropriate carrier immediately. If undamaged, open the package and inspect the device for obvious damage. Return damaged products.

## Requirements

- Tools (not provided): Pipe wrenches
- Training: Installer must be a qualified, experienced technician
- Appropriate accessories

---

**Caution:**

- Install the valve with the flow in the direction of the flow arrows (“A” and “B” ports are inlets and “AB” port is the outlet).
  - Do not exceed the ratings of the device.
  - Avoid locations where excessive moisture, corrosive fumes, or vibration are present.
- 

## Mounting

1. The valve should be mounted in a weather-protected area in a location that is within the ambient limits of the actuator. When selecting a location, allow sufficient room for valve linkage, actuator, and other accessories and for service of the product.
2. The preferred mounting position for the valve is with the valve stem vertical above the valve body. Avoid mounting the valve so that the valve stem is below horizontal.
3. The valves must be piped with two inlets (“A” and “B” ports) and one outlet (“AB” port).

### Screwed Valve Bodies

The VB-7315-0-4-P series screwed valve bodies conform to ISO 7/1, BS 21, JIS B0203, Internal Parallel Pipe Thread (R<sub>p</sub>).

1. Apply pipe dope sparingly to all but the last two threads of a properly threaded, reamed, and cleaned pipe. Make sure that pipe chips, scale, etc. do not get into the pipe since this material may lodge in the valve seat and prevent proper closing and opening of the valve.
2. Start the joint by hand screwing the pipe into the valve. If the thread engagement feels “right,” turn the pipe by hand as far as it will go.
3. Use a pipe wrench to fully tighten the valve to the pipe. Do not over tighten or strip threads. See Table-6 and Figure-3 for the normal engagement length of the threads. Figure-4 shows a means of tightening the pipe so that the valve is not twisted or crushed.

**Table-6 Normal Thread Engagement Between Male Pipe Thread and Valve Body.**

Valve Size in mm (R <sub>p</sub> )	Normal Engagement in mm	Valve Size in mm (R <sub>p</sub> )	Normal Engagement in mm
15 (1/2)	13	32 (1-1/4)	17
20 (3/4)	14	40 (1-1/2)	17
25 (1)	17	50 (2)	19

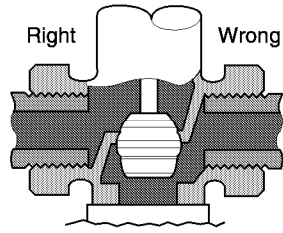

Figure-3 Normal Thread Engagement.

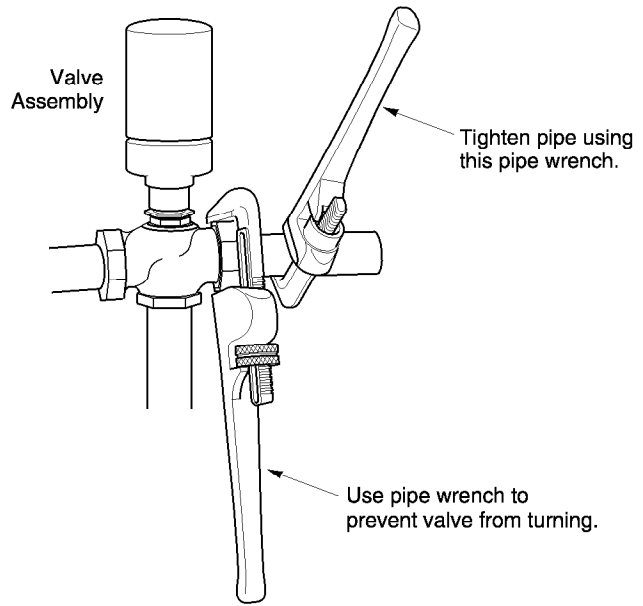

Figure-4 Installation of Screwed End Valves.



# TYPICAL PIPING

All piping must comply with local codes and ordinances. Refer to Figure-5 through Figure-7 for typical piping.

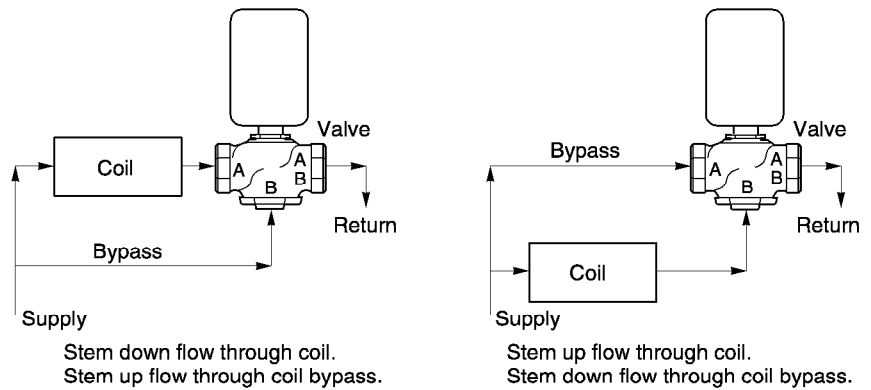

Figure-5 Typical Piping for Control of Heating or Cooling Coil.

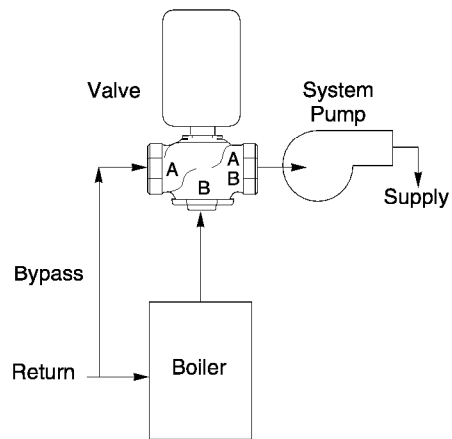

Figure-6 Typical Boiler Hot Water Reset.

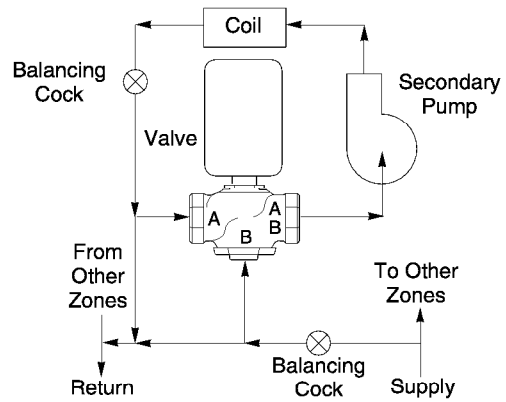

Figure-7 Typical Primary-Secondary Piping.

## CHECKOUT

1. Make sure the valve stem operates smoothly before installing the valve linkage and the actuator.
2. If the stem does not operate smoothly, it may indicate that the valve was twisted or crushed during installation or that the stem was bent by rough handling. These conditions may require that the valve be replaced.
3. After the piping is under pressure, check the valve body and the connections for leaks.
4. After the valve linkage and the actuator are installed, check their operation.
  - a. Drive the actuator and run the valve to the stem down position. Make sure the linkage and valve stem move freely. At the stem down position, the valve should shut off the "B" port.
  - b. Drive the actuator and valve to the stem up position. Again, the valve stem and linkage should operate smoothly. At the stem up position, the valve should shut off the "A" port.

## MAINTENANCE

Regular maintenance of the total system is recommended to assure sustained performance. See Table-7 for maintenance kit part numbers.

**Table-7 Maintenance Kits for VB-7315 Valves.**

Valve Body Part Number	Replacement Packing Assembly	Packing Wrench	Valve Repair Kit <sup>a</sup>
VB-7315-0-4-2	YBA-622-1	TOOL-20-1	RYB-731-2
VB-7315-0-4-4			RYB-731-4
VB-7315-0-4-6			RYB-731-6
VB-7315-0-4-8			RYB-731-8
VB-7315-0-4-9			RYB-731-9
VB-7315-0-4-10			RYB-731-10
VB-7315-0-4-11			RYB-731-11

<sup>a</sup> Kit includes replacement packing and stem & plug assembly.

## Water System Maintenance

All heating and cooling systems are susceptible to valve and system problems caused by improper water treatment and system storage procedures. These guidelines are provided to help avoid valve and water system problems resulting from improperly treated water or storage procedures in cooling and hot water systems, and to obtain maximum life from Siebe Environmental Controls valves.

Durability of valve stems and packings is dependent on maintaining non-damaging water conditions. Inadequate water treatment or filtration, not in accordance with chemical supplier/ASHRAE handbook recommendations, can result in corrosion, scale, and abrasive particle formation. Scale and particulates can result in stem and packing scratches and can adversely affect packing life and other parts of the hydronic system.

To maintain non-damaging conditions, follow these guidelines:

- Clean the system prior to start up. Use a nitrite or molybdate-based treatment program.
- Use filtration equipment where needed.
- Properly store off-line systems and monitor water treatment results using corrosion test coupons.
- Follow the advice of a water treatment professional.
- Consult **EN-205, Water System Guidelines Engineering Information, F-26080**, for further details.

# DIMENSIONAL DATA

**Table-8 Dimensions for VB-7315 Series Valves (Figure-8).**

Part Number	Valve Size in mm (Rp)	Dimensions in Inches (mm)				
		A	B	C	D (Stem Down)	E (Stroke)
VB-7315-0-4-2 VB-7315-0-4-4	15 (1/2)	78	35	43	19	11
VB-7315-0-4-6	20 (3/4)	92	43			
VB-7315-0-4-8	25 (1)	118	40	45		
VB-7315-0-4-9	32 (1-1/4)		41	51		
VB-7315-0-4-10	40 (1-1/2)	137	40	29		
VB-7315-0-4-11	50 (2)	156	48	30		

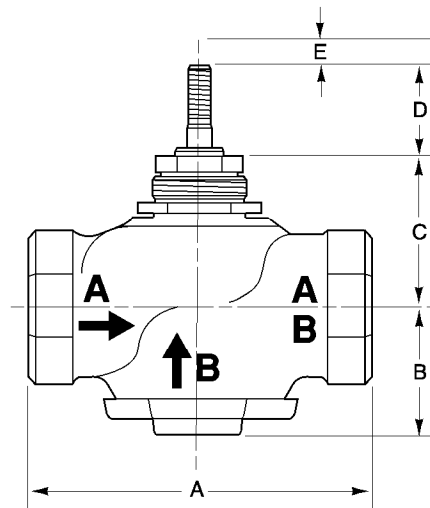

Figure-8 Typical of VB-7315-0-4-P Valve Bodies.

