



Siebe Environmental Controls
1354 Clifford Avenue (Zip 61111)
P.O. Box 2940
Loves Park, IL 61132-2940
United States of America

An Invensys company

VF2X Series

1/2" to 1" NPT Threaded
15 mm to 25 mm R_p Threaded
1/2" to 1" Sweat End
Spring Return, Floating
Two-Way Electric Valves
General Instructions

Application

VF2X series spring return, floating, two-way valves incorporate equal percentage characteristics to provide close temperature control on heating or cooling fan coil units, unit ventilators, reheat coils, and perimeter heating systems.

In the case of power failure, a return spring sends the valve to its normal position. These valves are available in normally open and normally closed configurations.

These VF2X series valves are compatible with virtually any three-wire floating control signal. An additional wire for constant 24 Vac supply is also required.

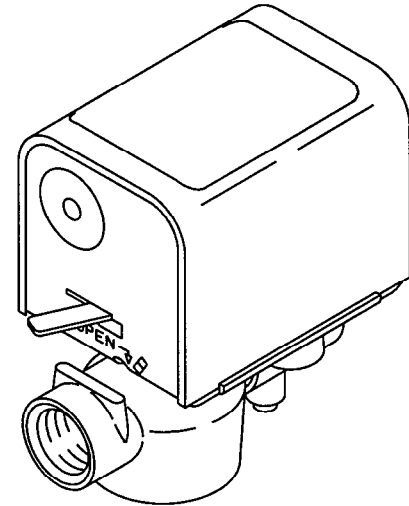

Features

- Spring return operation to provide for a fail-safe position
- Magnetic clutch to extend the life of the actuator and gear train
- Manually operated lever and position indicator to facilitate field setup

Applicable Literature

- EN-206, Guidelines for Powering Multiple Devices from a Common Transformer, F-26363

SPECIFICATIONS

Operating Pressure Limits: 300 psi (20.7 Bar).
Flow Characteristic: Equal percentage.
Service: Hot and chilled water, up to 50% glycol.
Control Signal: Nominal 24 Vac, -15%, +10%, 50/60 Hz.
SPDT Center Off (Floating) Control Contacts or Two SPST Control Contacts, Minimum rating of 250 mA @ 24 Vac inductive load.
Two Triacs, DDC output must be able to switch 250 mA (24 VA) inductive load (150 Vac minimum).
Current Requirement (24V Supply): 12 VA (in rush), 100 mA continuous.
Stroke Speed: 2 minutes from full open to full close at 60 Hz.
Maximum Close-off Pressure: Refer to Table-1.
Seat Leakage: Zero leakage (100% bubble-tight close-off).
Fluid Temperature Limits: 32 to 200°F (0 to 93°C).
Max. Ambient Temperature and Humidity: 125°F (52°C) at 95% RH, non-condensing.
Materials:
Body, Forged brass.
Stem, Chrome-plated brass.
Seat, Stainless steel for A and B pipe codes. Chrome-plated brass for C pipe code.
Plug, High temperature thermoplastic for A and B pipe codes. Buna-N for C pipe code.
Actuator, Stainless steel base plate with aluminum cover.
Wiring Connections: Terminal strip.
Shipping Weight: 3.0 lbs. (1.36 kg).

Table-1 Maximum Close-off Pressure.

Flow Coefficient $C_v (k_{vs})^a$	Operating Mode (driven closed) psi (kPa)	Power Failure Mode (spring close) ^b psi (kPa)
0.7 to 1.5 (0.6 to 1.3)	50 (344)	50 (344)
2.5 (2.2)	50 (344)	20 (137)
4 (3.5)	35 (241)	20 (137)
8 (6.9)	35 (241)	15 (103)

^a $k_{vs} = m^3/h (\Delta P = 100 \text{ kPa})$

^b If valve is driven closed before a power failure, the "operating mode" close-off pressures apply.

Part Numbering System

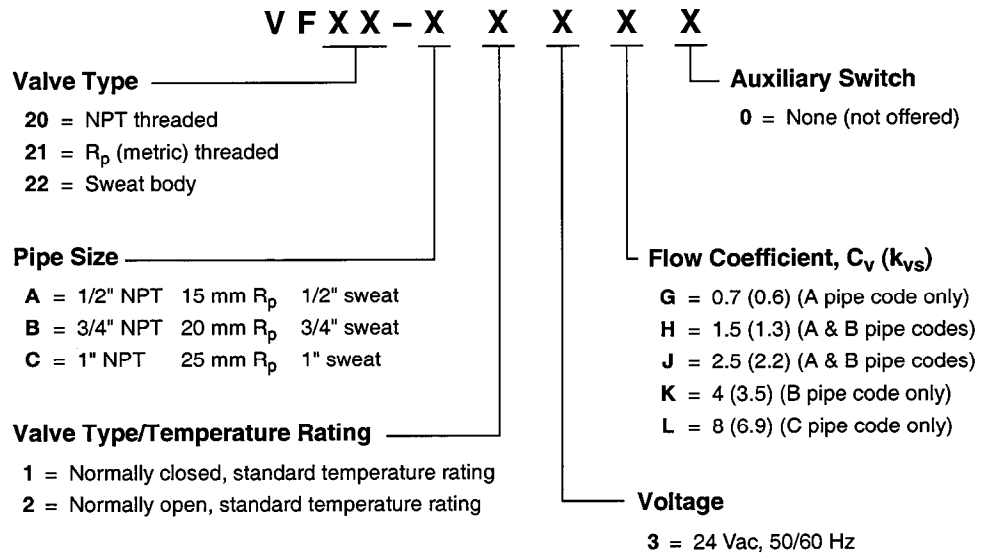

Not all of the above combinations are possible or available.

TYPICAL APPLICATIONS (Piping and Wiring Diagrams)

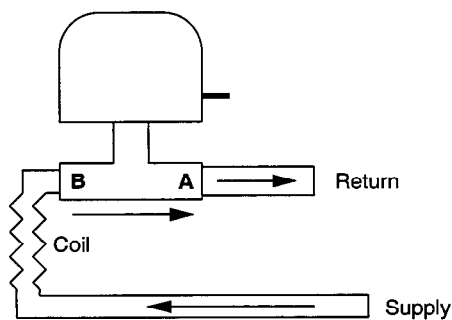

Figure-1 Typical Piping.

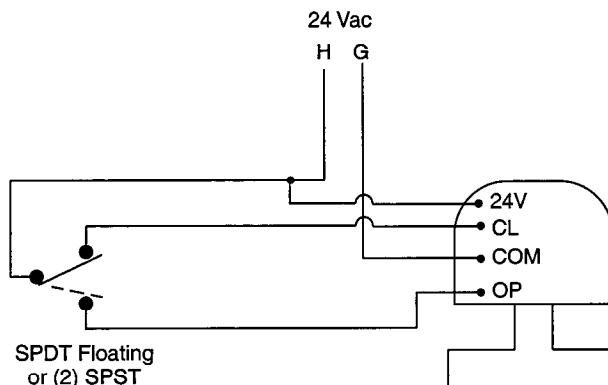

Figure-2 Typical Wiring Diagram.

INSTALLATION

Inspection

Inspect the package for damage. If damaged, notify the appropriate carrier immediately. If undamaged, open the package and inspect the device for obvious damage. Return damaged products.

Requirements

- Training: Installer must be a qualified, experienced technician
- Appropriate accessories

Caution:

- Do not exceed the ratings of the device.
 - If the manual operating lever does not move freely for manual positioning, the solenoid may have latched during shipping. Do not force the lever when the solenoid is latched. The solenoid may be unlatched by applying 24 VAC to the valve for 5 seconds, or by pushing the solenoid plunger down with a small screwdriver inserted into the slot below the solenoid. The manual operating lever is provided only on normally closed valves.
 - Use of a properly sized, inherently limited, Class 2 transformer is recommended. Continuous operation with supply voltages well above the nominal may reduce motor life.
 - Avoid locations where excessive moisture, corrosive fumes, or vibration are present.
-

Piping

These valves must be piped so that the plug closes against the direction of flow. Flow is from B to A. Refer to Figure-1. On normally closed valves the B port is normally closed and opens with increasing signal. On normally open valves, the B port is normally open and closes with increasing signal.

When sweating a normally closed valve, it is necessary to manually open the valve to avoid damaging the plastic and rubber goods in the valve body. This is done by positioning the manual operating lever located on the side of the valve to the mid-position notch. Once installation is complete and the valve body cools, return the lever to the normally closed position before wiring.

Wiring

Terminal identification for these valves is as follows:

- 24V 24 Volt Supply Voltage
- CL Valve Close
- COM Valve Common
- OP Valve Open

When connecting multiple valves to a single controller, all valves should be driven to the full open or full closed position for a minimum of 3 minutes during initial installation. Be sure not to exceed the maximum amp draw of the controller.

Application Tips

The controller that is used to operate these valves should be configured to turn off the control signal after being on continuously for 3 minutes. This measure will extend the life of the actuator.

The spring return feature is a fail-safe feature only. It is not intended for use as a control device on the valve and should not be used on a regular basis to open or close the valve. There is a 5 to 7 second time delay upon loss of power to prevent loss of valve position during brief outages. There is a 1 to 3 second time delay on power up.

DIMENSIONAL DATA

Table-2 Mounting Dimensions (Figure-3).

Part Number	Valve Size	Dimensions in inches (mm)		
		A	B	C
VF20-XXXXX NPT	1/2"	1-5/16 (33)	2-3/16 (55)	3-7/8 (98)
	3/4"	1-3/4 (44)	2 (51)	4-1/4 (108)
	1"			
VF21-XXXXX Rp	15 mm	1-5/16 (33)	2-3/16 (55)	3-7/8 (98)
	20 mm	1-3/4 (44)	2 (51)	4-1/4 (108)
	25 mm			
VF22-XXXXX Sweat	1/2"	1-5/16 (33)	2-3/16 (55)	3-7/8 (98)
	3/4"	1-3/4 (44)	2-3/8 (60)	4-1/8 (105)
	1"			

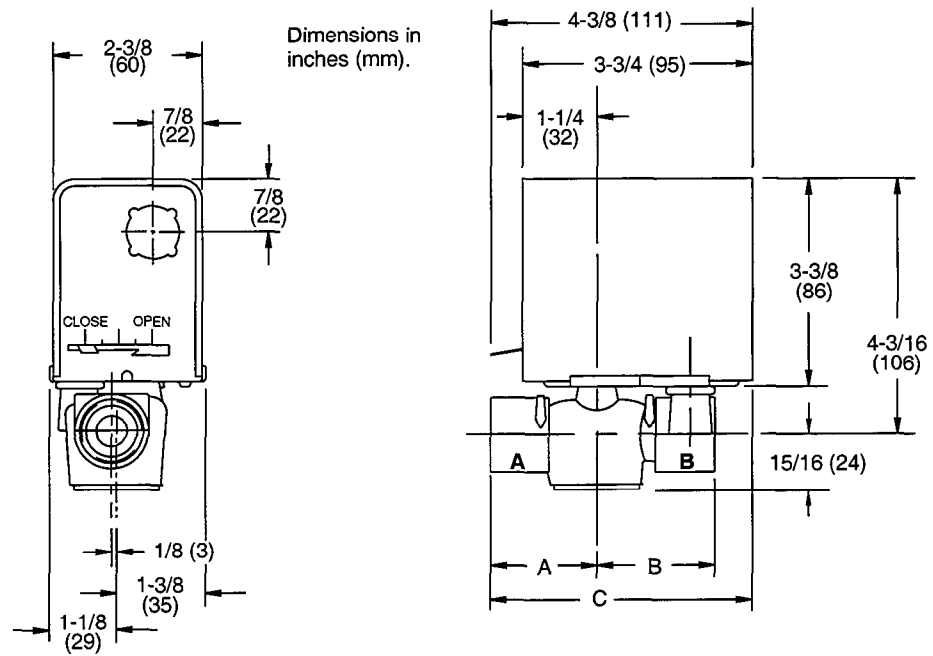

Figure-3 Mounting Dimensions.