



Siebe Environmental Controls
1354 Clifford Avenue (Zip 61111)
P.O. Box 2940
Loves Park, IL 61132-2940
United States of America

An Invensys company

VS2X Series

1/2" to 1" NPT Threaded
15 mm to 25 mm R_p Threaded
1/2" to 1" Sweat End
Spring Return, Proportional
Two-Way Electric Valves
General Instructions

Application

VS2X series spring return, proportional, two-way valves incorporate equal percentage characteristics to provide precise control of fluid flow in a wide variety of heating and cooling applications.

In the case of power failure, a return spring sends the valve to its normal position. These valves are available in normally open and normally closed configurations.

These microprocessor-controlled VS2X series valves are compatible with virtually any 0 to 10 Vdc or 4 to 20 mA signal. Feedback is accomplished through optical sensing of reflective and non-reflective areas on the clutch housing of the actuator. This non-contact method provides much longer life than a mechanical potentiometer interface.

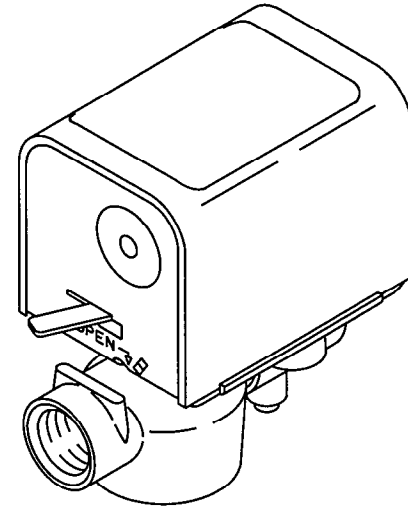

Features

- Spring return operation to provide for a fail-safe position
- Magnetic clutch to extend the life of the actuator and gear train
- Microprocessor for self-calibration and diagnostics
- Jumper selectable operating range and action
- Manually operated lever and position indicator to facilitate field setup
- Three LEDs for user information and diagnostics

Applicable Literature

- EN-206, Guidelines for Powering Multiple Devices from a Common Transformer, F-26363

SPECIFICATIONS

Operating Pressure Limits: 300 psi (20.7 Bar).
Flow Characteristic: Equal percentage.
Service: Hot and chilled water, up to 50% glycol.
Supply Voltage: Nominal 24 Vac, -15%, +25% (20 to 30 Vac), 50/60 Hz.
Control Signal: Nominal 0 to 10 Vdc. Actual 1.0 to 9.0 Vdc.
 Jumper selectable 0 to 5 Vdc, 5 to 10 Vdc, 0 to 10 Vdc operation, or 4 to 20 mA control.
Control Action: Direct acting (valve opens B port on increase in signal).
 Field selectable reverse acting.
Input Impedance:
 Voltage, 200 k Ω .
 Current, 150 Ω .
Current Rating: 200 mA running (1A peak for solenoid). 10 VA power requirement.
Stroke Speed: 2 minutes from full open to full close at 60 Hz.
Maximum Close-off Pressure: 50 psi (344 kPa) for 0.7 to 2.5 C_v (0.6 to 2.2 k_{vs}).
 35 psi (240 kPa) for 4 and 8 C_v (3.5 and 6.9 k_{vs}). Refer to Table-1 for solenoid (fail-safe) close-off ratings.
Seat Leakage (service port): Zero leakage (100% bubble-tight close-off).
Fluid Temperature Limits: 32 to 200°F (0 to 93°C).
Max. Ambient Temperature and Humidity: 125°F (52°C) at 95% RH, non-condensing.
Shipping Weight: 3.0 lbs. (1.36 kg).

Table-1 Maximum Close-off Pressure.

| Flow Coefficient C _v (k _{vs}) ^a | Operating Mode (driven closed) psi (kPa) | Power Failure Mode (spring close) ^b psi (kPa) |
|--------------------------------------------------------------------|---------------------------------------------|-------------------------------------------------------------|
| 0.7 to 1.5 (0.6 to 1.3) | 50 (344) | 50 (344) |
| 2.5 (2.2) | 50 (344) | 20 (137) |
| 4 (3.5) | 35 (241) | 20 (137) |
| 8 (6.9) | 35 (241) | 15 (103) |

^a k_{vs} = m³/h ($\Delta P = 100$ kPa)

^b If valve is driven closed before a power failure, the "operating mode" close-off pressures apply.

Part Numbering System

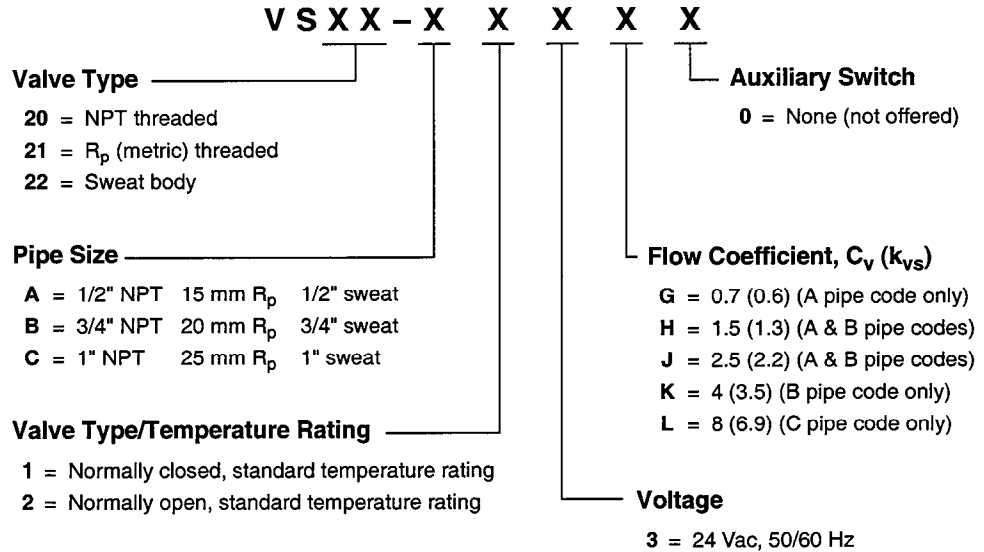

Not all of the above combinations are possible or available.

TYPICAL APPLICATIONS (Piping and Wiring Diagrams)

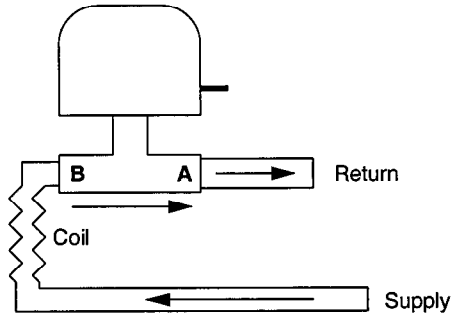

Figure-1 Typical Piping.

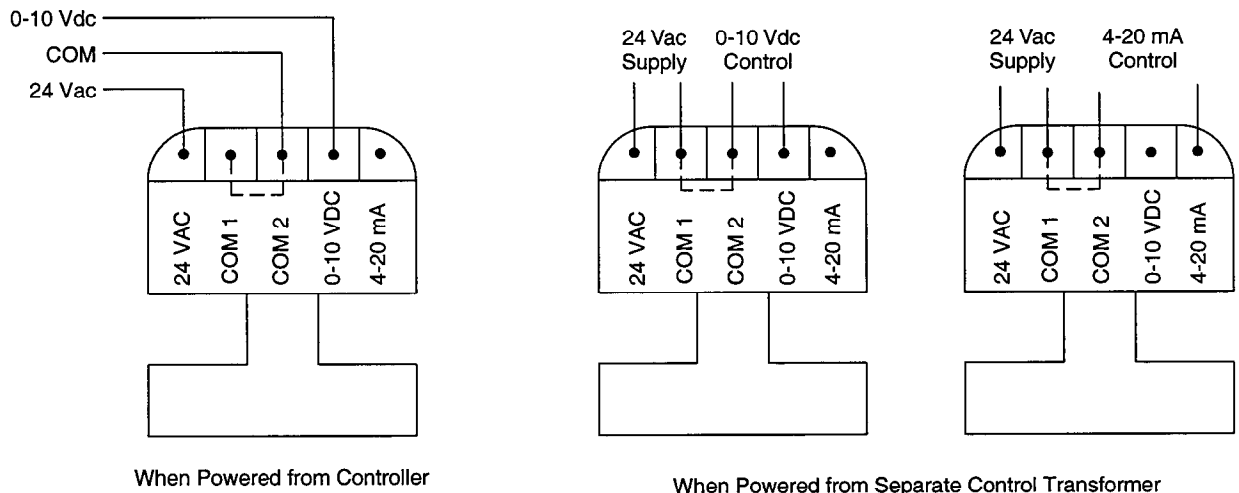

Figure-2 Typical Wiring Diagram.

INSTALLATION

Inspection

Inspect the package for damage. If damaged, notify the appropriate carrier immediately. If undamaged, open the package and inspect the device for obvious damage. Return damaged products.

Requirements

- Training: Installer must be a qualified, experienced technician
- Appropriate accessories

Caution:

- Do not exceed the ratings of the device.
 - The cover must be on at all times during normal operation. If the cover is removed for troubleshooting, the photo sensor must be shielded from bright light.
 - This product contains a non-isolated half-wave rectifier power supply and must not be powered by transformers used to power other devices containing non-isolated full-wave rectifier power supplies. Refer to **EN-206, Guidelines for Powering Multiple Devices from a Common Transformer, F-26363**, for detailed information.
 - Avoid locations where excessive moisture, corrosive fumes, or vibration are present.
-

Piping

These valves must be piped so that the plug closes against the direction of flow. Flow is from B to A. Refer to Figure-1.

Field Setup

Operating Range

The VS2X series actuator is furnished with a jumper to allow for different operating ranges of the valve (Figure-3). All units are shipped with the jumper in the 0 to 10 Vdc position. To change the operating range, remove the jumper and install it on the 0 to 5 Vdc or 5 to 10 Vdc pins, or 4 to 20 mA pins.

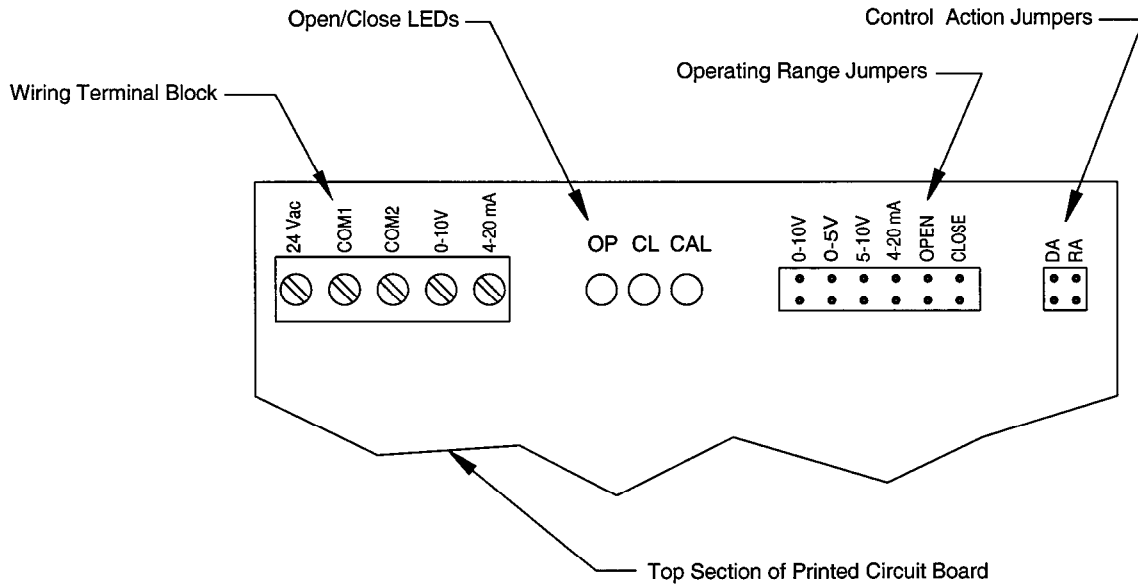

Figure-3 Actuator Board Features.

Control Action

The actuator is also provided with a jumper to allow the action to be reversed. All units are shipped with the actuator in the DA (direct acting) mode, which means that the valve opens B port upon receiving an increasing control signal. To change the action to reverse action (valve closes B port upon receiving an increasing control signal), remove the action jumper and relocate it to the RA (reverse acting) pins.

Calibration

The VS2X series valve self-calibrates on power-up by counting the actuator rotations as the valve runs full stroke. It resets its zero position every time the valve closes and re-zeros every 10 days. While calibrating and running, LEDs indicate the status of the valve. The LEDs also aid in the diagnosis of any problems.

Status Indication

Setpoint Satisfied: All LEDs off and actuator off.

Valve Closing: Red LED on continuously, except 4 to 5 times per second indicating motion detection.

Valve Opening: Green LED on continuously, except 4 to 5 times per second indicating motion detection.

Calibrating and Zeroing: Red and Green LEDs as above and Yellow LED flashing twice per second.

Low Power-up Voltage (< 20 Vac): Red and Green LEDs off and Yellow LED flashing twice per second.

Low Operating Voltage (< 18 Vac): All LEDs off. Valve spring returns after 5 seconds.

Motor/Circuit Failure: Red, Green, and Yellow LEDs on continuously. No operation until power loss or daily reset.

Gear/Solenoid Failure: Yellow LED on and normal operation attempted.

Wiring

Refer to Figure-2 for wiring details. Multiple valves may be connected to a single controller, up to the current rating of the controller and transformer.

Caution: Use of a properly sized, inherently limited, Class 2 transformer is recommended. Continuous operation with supply voltages well above the nominal may reduce actuator life.

Mounting

The VS2X series valves can be mounted in horizontal or vertical piping. When installed in horizontal piping, the actuator must be above the valve body, with the circuit board protected from moisture damage. Refer to Figure-4.

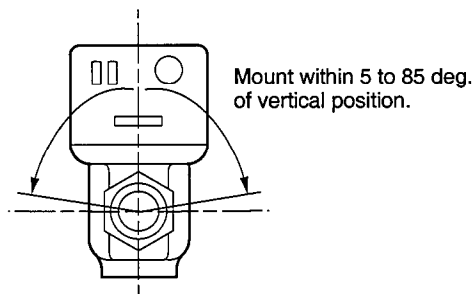

Figure-4 Mounting Position.

Manual Override Feature

Without 24 Vac supply, the valve will assume its “normal” position by failing-safe to either N.O. or N.C.

Manual Lever/Position Indicator

The manual lever serves as a valve position indicator. When the valve is not under power, it can position the valve in the mid-range. To manually position the valve while it is under power, use the operating range jumper. (Refer to the “OPEN” or “CLOSE” operating range jumper settings in Figure-3.)

When soldering sweat valves, use the manual lever to position the valve in mid-range and protect the seals from the heat of soldering.

Note: A “time out” feature is provided to turn the actuator (and LEDs) off within 5 seconds of reaching fully open or closed.

Caution: If the manual lever does not move freely for manual positioning, the solenoid may have latched during shipping. Do not force the lever when the solenoid is latched. The solenoid may be unlatched by applying 24 Vac to the valve for 5 seconds, or by pushing the solenoid plunger down with a small screwdriver inserted into the slot below the solenoid.
