



The Complete Erie Product Family

Copyright Notice

The confidential information contained in this document is provided solely for use by Invensys employees, licensees, and system owners, and is not to be released to, or reproduced for, anyone else. Neither is it to be used for reproduction of this control system or any of its components.

All specifications are nominal and may change as design improvements occur. Invensys shall not be liable for damages resulting from misapplication or misuse of its products.

Invensys Building Systems, Inc.

1354 Clifford Avenue
P.O. Box 2940
Loves Park, Illinois 61132-2940
United States of America

www.invensysibs.com

© Copyright 2003 Invensys plc. All rights reserved.

No part of this document may be photocopied or reproduced by any means, or translated to another language without prior written consent of Invensys.

Invensys, Boiler Boss, Erie, PopTop, and Priority Plus are trademarks of Invensys plc and its subsidiaries and affiliates.

All other trademarks are the property of their respective owners.



Table of Contents

PopTop Series	1
Two Position Zone Valve Spring Return	1
AG, AH Series	1
Two Position Zone Valve with Actuator, Spring Return	2
Two Position Zone Valve Two-Way and Three-Way	3
VT, VS Series	3
Two Position Spring Return Actuators	5
AG, AH Series	5
Two Position Spring Return PopTop, Two-Way and Three-Way VT, VS General Assemblies	6
Two Position Spring Return PopTop, Two-Way and Three-Way VT, VS High Close-Off Assemblies ...	7
Two Position Zone Valves with Actuators, Spring Return	8
Modulating Valve, Spring and Non-Spring Return	11
AT, AP Series	11
Modulating Zone Valve with Actuator, Spring and Non-Spring Return	12
Modulating Zone Valve Two-Way and Three-Way VM Series	13
Modulating, Spring and Non-Spring Return PopTop Two-Way and Three-Way VM Assemblies	15
Modulating Spring and Non-Spring Return PopTop, Two-Way and Three-Way VM Assemblies	16
Damper Actuators	19
Two Position Damper Actuator Direct and Linkage Drive	19
453X Series	19
453R	21
Two Position Heavy Duty Damper Actuator	21
Floating Valve Actuator	23
MF-631X3 Series	23
Control Module Card	25
MFC-420	25
Control Module Card	27
MFC-8000	27
Reversible and Proportional Electric Actuators	29
Reversible and Proportional Electric Actuators	29
MP-3XX Series	29
Electric Actuator Drive	33
Electronic Actuator Drive	33
CP-9301-XXX Series, CP-9302 Series	33
2-Way Globe Valves with Electric Gear Train Actuators	37
3-Way Globe Valves with Electric Gear Train Actuators	39

Table of Contents

Valves	41
Two-Way Valve	41
VB-7213	41
Three-Way Mixing Valve	43
VB-7313	43
Two-Way Valve	45
VB-9213	45
Three-Way Mixing Valve	47
VB-9313	47
Valve Linkage for Gear Train Actuators	49
Valve Linkage for Gear Train Actuators	49
AV-352	49
Valve Linkage for Gear Train Actuators	51
AV-390	51
Globe Valves and Actuators	53
Globe Valve Actuator	53
VAT/VAP100 Series	53
Globe Valve Actuator	55
VAT/VAP270 Series	55
Globe Valve Actuator	57
VAT/VAP340 Series	57
Flanged Globe Valve Bodies	59
VBF Series	59
Threaded Globe Valve Bodies	63
VBG Series	63
Boiler Boss Radiant Controls	65
Universal Boiler Reset Control	65
BB1200	65
Boiler Control	67
BB2400 Series	67
Injection Mixing Pump Control	71
BB3000	71
Three-Way Mixing Valve Control	73
BB3600	73
Hydronic Controls	75
Zone Control Relay	75
SR100 Series	75
Multi-Zone Circulation Control Relay	77
SR201/301/601 Series	77
Zone Valve Control Center	81
VL500	81
Two Zone Hydro-Air Relay	85
WA300	85

Table of Contents

Electronic Thermostats	87
Electronic On/Off Thermostat/Controller	87
T155 Series	87
Digital, Three-Wire Floating Thermostat/Controller	91
T158 Series	91
Digital, Proportional Thermostat/Controller	95
T168 Series	95
Digital, On/Off Thermostat	99
T200 Series	99
Mechanical Thermostats	101
On/Off Low/Line Voltage Thermostat/Controller	101
T500 Series	101
On/Off Thermostat	103
31-100 Series	103
Seasonal Changeover Switch	105
680 Series	105
List of Accessories	107
Accessories	107
Application Tips	109
Application Tips	109

Table of Contents

Application

PopTop™ Series valve bodies and actuators provide easy installation for a variety of heating and cooling applications.

Valve's actuator can be installed after valve body has been installed onto fan coil, baseboard or air handler.

VS Series valves are available for low pressure steam applications.

Features

- Direct replacement for all existing two-position PopTop applications
- Hysteresis synchronous motor for long life
- Spring return operation
- Valve body rated for 300 psig static pressure
- Available in a variety of voltages
- Actuator mounts directly onto the valve body without the need for linkages or calibration
- Manual override lever (normally closed only)
- Actuator can be replaced without any tools, or removal of the valve from the system
- VS Series valve available for low pressure steam

Actuator Specifications

Voltage: 24 Vac @ 50/60 Hz., 110 Vac @ 50 Hz. and 120 Vac @ 60Hz., 230 Vac @ 50 Hz. and 240 Vac @ 60 Hz., 208 Vac @ 50/60 Hz., 277 Vac @ 50/60 Hz.

Power Requirements: 6.5 watts, 7.5 Va.

End Switch: 24 to 240 Vac Models: 24 to 240 Vac/101 mA minimum to 5 A maximum, and 9 to 36 Vdc @100 mA maximum.

277 Vac Models: 277 Vac/101 mA minimum to 5 A maximum.

Control Signal: On/off, 2 position, spring return.

Timing, Full Open to Full Close: 25 Sec maximum for 60 Hz; 30 Sec maximum for 50 Hz; and 9 Sec maximum spring return.

Materials: Stainless steel base plate, aluminum cover.

Ambient Temperature Limits:

Shipping & Storage,

-40 to 160 °F (-40 to 71 °C).

Operating,

Refer to Table 1.

Humidity: 5 to 95% relative humidity, non-condensing.

Agency Listings: *UL873:* Underwriters laboratories (File #E9429 Category Temperature Indicating and Regulating Equipment) *CUL:* UL Listed for use in Canada by Underwriters Laboratory. Canadian Standards C22.2 No. 24. *European Community:* EMC Directive (89/336/EEC). Low Voltage Directive (72/23/EEC). *Australia:* This product meets requirements to bear the C-Tick Mark according to the terms specified by the Communications Authority under the Radio Communications Act of 1992.

Shipping Weight (Actuator/Valve Assy.): 2.25 lbs (1020 g).



VT/VS Series Valve with General Close-Off Actuator AG Series



VT/VS Series Valve with High Close-Off Actuator AH Series

TABLE 1. Operating Temperature Range

Model	Valve Body Temperature Range
VTxxxx	32 to 200 °F (fluid) @ 104 °F (Ambient) (0 to 93 °C @ 40 °C)
VSxxxx	32 to 250 °F (fluid) @ 169 °F (Ambient) (0 to 121 °C @ 76 °C), and/or 15 PSI (103 kPa) Steam ^a
Model	Actuator Temperature Range
Axx3xxx	32 to 200 °F (fluid) @ 104 °F (Ambient) (0 to 93 °C @ 40 °C)
Axx4xxx	32 to 250 °F (fluid) @ 169 °F (Ambient) (0 to 121 °C @ 76 °C), and/or 15 PSI (103 kPa) Steam ^a

^a For steam applications, both valve body and valve actuator must be rated for high temperature.

Specifications for Valve Body Assemblies

Service: Hot and chilled water models, up to 50% glycol. Steam models up to 15 psi (both valve body and valve actuator must be rated for steam).

System Static Pressure Limits: 300 psig (2068 kPa).

Close-off: Refer to Table 3.

Fluid/Ambient Temperature Limits: Refer to Table 1.

Seat Leakage: ANSI class IV (0.01%) with pressure at inlet (B-port/A-port if 3-way).

Body : Forged brass.

Stem: Nickel-plated.

Seat: Brass.

Paddle (VT series): Buna N.

Paddle (VS series): Highly saturated nitrile.

Accessories

436-214-1	Union nut & elbow assembly, female for 1/2" (5/8" O.D.) copper, 15/16" long
436-214-4	Union nut & elbow assembly, male for 1/2" (5/8" O.D.) copper, 1-15/16" long
436-220	Union nut & coupling assembly, female for 1/2" (5/8" O.D.) copper, 1-1/16" long
436-229-3	Union nut & nipple assembly, male for 1/2" (5/8" O.D.) copper, 3" long
436-252	Union nut & coupling assembly, female for 3/4" (7/8" O.D.) copper, 1-27/32" long
436-256	Union nut & coupling assembly, female for 1" (1-1/8" O.D.) copper, 1-3/8" long

Two Position Zone Valve with Actuator, Spring Return

AG, AH Series



TABLE 2. Water Valve Sizing (gallons per minute)

	ΔP	1.0 Cv	1.5 Cv	2.5 Cv	3.0 Cv	3.5 Cv	4.0 Cv	5.0 Cv	7.5 Cv	8.0 Cv
Differential Pressure, ΔP	1 PSI	1.0	1.5	2.5	3.0	3.5	4.0	5.0	7.5	8.0
	2 PSI	1.4	2.1	3.5	4.2	4.9	5.7	7.1	10.6	11.3
	3 PSI	1.7	2.6	4.3	5.2	6.1	6.9	8.7	13.0	13.9
	4 PSI	2.0	3.0	5.0	6.0	7.0	8.0	10.0	15.0	16.0
	5 PSI	2.2	3.4	5.6	6.7	7.8	8.9	11.2	16.8	17.9

$$GPM = Cv \sqrt{\Delta P}$$

TABLE 3. AG, AH Series Flow Coefficients and Maximum Close-Off Pressure

Valve Size	Connection Type	2-way Cv (kv)	3-way Cv (kv)	(G) ^a Close-Off ΔP PSI (kPa)	(H) ^b Close-Off ΔP PSI (kPa)
1/2"	NPT, SW, SAE, and Rp	1.0 (0.9)	1.5 (1.3)	60 (414)	75 (517)
3/4"	IFL				
1/2"	NPT, SW, SAE, and Rp	2.5 (2.2)	3.0 (2.6)	40 (276)	50 (344)
3/4"	NPT, SW, IFL, and Rp				
1/2"	NPT, SW, SAE, and Rp	3.5 (3.0)	4.0 (3.4)	25 (172)	30 (208)
3/4"	NPT, SW, IFL, and Rp				
1"	SW	5.0 (4.3)	5.0 (4.3)	20 (137)	25 (172)
3/4"	NPT, SW, and Rp				
1"	SW	7.5 (6.5)	7.5 (6.5)	17 (117)	20 (137)
3/4"	NPT, SW, and Rp				
1"	SW	8.0 (6.9)	8.0 (6.9)	17 (117)	20 (137)
1"	NPT and Rp				
1-1/4"	SW				

Valve Body Legend

- NPT — Threaded (female)
- SW — Sweat
- IFL — Inverted Flare
- SAE — Society Automotive Engineers Flare (male)
- Rp — "Metric" Threaded (female)

^a G = General close-off actuator

^b H = High close-off actuator

Part Numbering System
Two Position Zone Valves, Spring Return Actuators

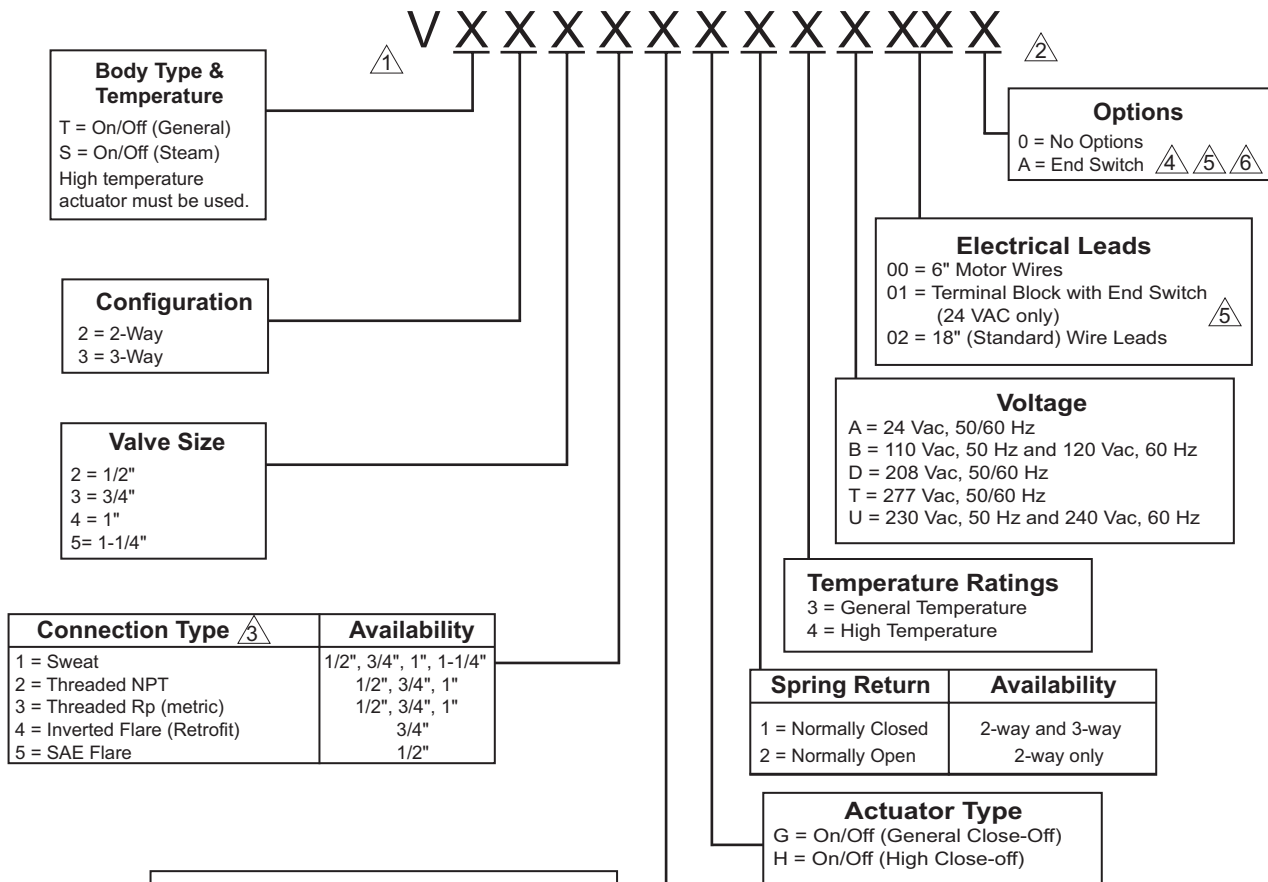

Connection Type ³	Availability
1 = Sweat	1/2", 3/4", 1", 1-1/4"
2 = Threaded NPT	1/2", 3/4", 1"
3 = Threaded Rp (metric)	1/2", 3/4", 1"
4 = Inverted Flare (Retrofit)	3/4"
5 = SAE Flare	1/2"

CV Size				
No.	2-way	3-way	Size	Connection Type
1 =	1.0	1.5	1/2"	1, 2, 3, 5
			3/4"	4
2 =	2.5	3.0	1/2"	1, 2, 3, 5
			3/4"	1, 2, 3, 4
3 =	3.5	4.0	1/2"	1, 2, 3, 5
			3/4"	1, 2, 3, 4
			1"	1
5 =	5.0	5.0	3/4"	1, 2, 3
			1"	1
7 =	7.5	7.5	3/4"	1, 2, 3
			1"	1
	8.0	8.0	1"	2, 3
			1-1/4"	1

- ¹ When ordering valve body only: use the first six positions to configure the valve.
- ² When ordering actuator only use the last seven positions to configure the actuator. Prefix with the letter "A".
- ³ Invensys inverted flare fittings must be ordered separately. See actuator accessories for fitting part numbers.
- ⁴ End switch is not available for 277 Vac models if actuator temperature rating is high temperature (4).
- ⁵ Actuators with Terminal blocks require endswitch and the endswitch is 24 Vac @ 101 mA min. - 5 A max.
- ⁶ End switch is 24 - 240 Vac @ 101 mA min. to 5 A max. and 9 - 36 Vdc @ 100 mA max. for actuators rated 240 V or less. End switch is 277 Vac @ 101 mA min. to 5 A max. for actuators rated 277 V.

Body & Actuator Combination Requirements

Temperature Configurations	
Body Configuration V I X X X X T = General S = Steam If body configuration is T, actuator temp rating can be 3 or 4. If body configuration is S, actuator temp rating must be 4.	Actuator Spring Return Mode A X X 3 X X X X 3 = General Temperature 4 = High Temperature If actuator temp rating is 3, body style must be T. If actuator temp rating is 4, body style can be S or T.

Two Position Zone Valve Two-Way and Three-Way

VT, VS Series



Two-Way Zone Valve



Three-Way Zone Valve

TABLE 4. PopTop On/Off Actuator Model Number Selection Guide.

VT	2	2	1	1		
Temp Rating	Configuration	Size	Connection	Cv	2-Way	3-Way
		2 = 1/2"	1 = Sweat	1 =	1.0	1.5
T = General	2 = 2-Way	3 = 3/4"	2 = NPT (female)	2 =	2.5	3.0
S = Steam	3 = 3-Way	4 = 1"	3 = Rp (female)	3 =	3.5	4.0
		5 = 1-1/4" (Sweat Only)	4 = Inverted Flare (3/4" only)	5 =	5.0	5.0
			5 = SAE Flare (1/2" only)	7 =	7.5/8.0	7.5/8.0

Catalog Part Number	Fitting Size	Type	Cv	
2-Way PopTop On/Off Two Position, Valve Body Only				
VT2211	1/2"	Sweat	1.0	
VT2212			2.5	
VT2213			3.5	
VT2221		NPT	1.0	
VT2222			2.5	
VT2223			3.5	
VT2231		Rp	1.0	
VT2232			2.5	
VT2233			3.5	
VT2251		SAE	1.0	
VT2252			2.5	
VT2253			3.5	
VT2312		3/4"	Sweat	2.5
VT2313				3.5
VT2315	5.0			
VT2317	7.5			
VT2322	NPT		2.5	
VT2323			3.5	
VT2325			5.0	
VT2327	Rp		7.5	
VT2332			2.5	
VT2333			3.5	
VT2335	Inverted Flare		5.0	
VT2337			7.5	
VT2341			1.0	
VT2342	Sweat		2.5	
VT2343		3.5		
VT2415		5.0		
VT2417	1"	NPT	7.5	
VT2427			Rp	8.0
VT2437				
VT2517	1-1/4"	Sweat		

Catalog Part Number	Fitting Size	Type	Cv	
3-Way PopTop On/Off Two Position, Valve Body Only				
VT3211	1/2"	Sweat	1.5	
VT3212			3.0	
VT3213			4.0	
VT3221		NPT	1.5	
VT3222			3.0	
VT3223			4.0	
VT3231		Rp	1.5	
VT3232			3.0	
VT3233			4.0	
VT3251		SAE	1.5	
VT3252			3.0	
VT3253			4.0	
VT3312		3/4"	Sweat	3.0
VT3313				4.0
VT3315	5.0			
VT3317	7.5			
VT3322	NPT		3.0	
VT3323			4.0	
VT3325			5.0	
VT3327	Rp		7.5	
VT3332			3.0	
VT3333			4.0	
VT3335	Inverted Flare		5.0	
VT3337			7.5	
VT3341			1.5	
VT3342	Sweat		3.0	
VT3343		4.0		
VT3415		5.0		
VT3417	1"	NPT	7.5	
VT3427			Rp	8.0
VT3437				
VT3517	1-1/4"	Sweat		

TABLE 5. Options Available: Modify model numbers as shown.

Options	Select
V_xxxx	For Steam, use "S"



AG Series Actuator



AH Series Actuator

TABLE 6. PopTop On/Off Actuator Model Number Selection Guide.

AG	1	3	A	02	0
Type/Close-Off	Action	Temp	Voltage	Electrical Connection	Options
G = On/Off General Close-Off H = On/Off "HCO" High Close-Off	1 = Normally Closed (2-Way and 3-Way) 2 = Normally Opened (2-Way only)	3 = General 4 = High Temp	A = 24 V @ 50/60 Hz B = 110 @ 50 Hz 120 V @ 60 Hz D = 208 V @ 50/60 Hz U = 230 V @ 50 Hz 240 V @ 60 Hz T = 277 V @ 50/60 Hz	00 = 6" Motor Wires 01 = Terminal Block, w/End Switch 02 = 18" Wires	0 = None A = End Switch

General Close-Off, Two-Position, Power Open or Close (25 Sec. Maximum @ 60 Hz), Spring Return Open or Close (9 Sec. Maximum)							
Normally Closed ^a				Normally Open ^b			
Model No.	Volts AC	End Switch	Wiring	Model No.	Volts AC	End Switch	Wiring
AG13A01A	24	•	Term. Block	AG23A01A	24	•	Term. Block
AG14A01A	24	•		AG24A01A	24	•	
AG13A020	24		18" Leads	AG23A020	24		18" Leads
AG13A02A	24	•		AG23A02A	24	•	
AG14A02A	24	•		AG24A02A	24	•	
AG13B020	120			AG23B020	120		
AG13B02A	120	•		AG23B02A	120	•	
AG14B02A	120	•		AG24B02A	120	•	
AG13D020	208			AG23D020	208		
AG13D02A	208	•		AG23D02A	208	•	
AG14D02A	208	•		AG24D02A	208	•	
AG13T020	277			AG23T020	277		
AG13T02A	277	•		AG23T02A	277	•	
AG13U020	230			AG23U020	230		
AG13U02A	230	•		AG23U02A	230	•	
AG14U02A	230	•		AG24U02A	230	•	
AG14A020	24			AG24A020	24		
AG14B020	120			AG24B020	120		
AG14D020	208			AG24D020	208		
AG14T020	277			AG24T020	277		
AG14U020	230			AG24U020	230		

^a 2-way or 3-way valve.

^b 2-way valve only.

High Close-Off, Two-Position, Power Open or Close (25 Sec. Maximum @ 60 Hz), Spring Return Open or Close (9 Sec. Maximum)							
Normally Closed ^a				Normally Open ^b			
Model No.	Volts AC	End Switch	Wiring	Model No.	Volts AC	End Switch	Wiring
AH13A01A	24	•	Term. Block	AH23A01A	24	•	Term. Block
AH14A01A	24	•		AH24A01A	24	•	
AH13A020	24		18" Leads	AH23A020	24		18" Leads
AH13A02A	24	•		AH23A02A	24	•	
AH14A02A	24	•		AH24A02A	24	•	
AH13B020	120			AH23B020	120		
AH13B02A	120	•		AH23B02A	120	•	
AH14B02A	120	•		AH24B02A	120	•	
AH13D020	208			AH23D020	208		
AH13D02A	208	•		AH23D02A	208	•	
AH14D02A	208	•		AH24D02A	208	•	
AH13T020	277			AH23T020	277		
AH13T02A	277	•		AH23T02A	277	•	
AH13U020	230			AH23U020	230		
AH13U02A	230	•		AH23U02A	230	•	
AH14U02A	230	•		AH24U02A	230	•	
AH14A020	24			AH24A020	24		
AH14B020	120			AH24B020	120		
AH14D020	208			AH24D020	208		
AH14T020	277			AH24T020	277		
AH14U020	230			AH24U020	230		

^a 2-way or 3-way valve.

^b 2-way valve only.

Two Position Spring Return PopTop, Two-Way and Three-Way VT, VS General Assemblies



**VT/VS Series Valves with
General Close-Off Actuator**

General Close-Off Valve and Actuator Assemblies					
2-Way Normally Closed					
Catalog Part Number	Size	Type	Cv	MOPD ^a (PSI)	
VT2211G13A020	1/2"	Sweat	1.0	60	
VT2212G13A020			2.5	40	
VT2213G13A020			3.5	25	
VT2221G13A020		NPT	1.0	60	
VT2222G13A020			2.5	40	
VT2223G13A020			3.5	25	
VT2231G13U020		Rp	1.0	60	
VT2232G13U020			2.5	40	
VT2233G13U020			3.5	25	
VT2251G13A020		SAE	1.0	60	
VT2252G13A020			2.5	40	
VT2253G13A020			3.5	25	
VT2312G13A020		3/4"	Sweat	2.5	40
VT2313G13A020				3.5	25
VT2315G13A020				5.0	20
VT2317G13A020	7.5		17		
VT2322G13A020	NPT		2.5	40	
VT2323G13A020			3.5	25	
VT2325G13A020			5.0	20	
VT2327G13A020	7.5		17		
VT2332G13U020	Rp		2.5	40	
VT2333G13U020			3.5	25	
VT2335G13U020			5.0	20	
VT2337G13U020	7.5		17		
VT2341G13A020	Inv. Flare		1.0	60	
VT2342G13A020			2.5	40	
VT2343G13A020			3.5	25	
VT2415G13A020	1"	Sweat	5.0	20	
VT2417G13A020			7.5	17	
VT2427G13A020		NPT	8.0	17	
VT2437G13U020		Rp	8.0	17	
VT2517G13A020	1-1/4"	Sweat	8.0	17	

General Close-Off Valve and Actuator Assemblies					
3-Way Normally Closed					
Catalog Part Number	Size	Type	Cv	MOPD ^a (PSI)	
VT3211G13A020	1/2"	Sweat	1.5	60	
VT3212G13A020			3.0	40	
VT3213G13A020			4.0	25	
VT3221G13A020		NPT	1.5	60	
VT3222G13A020			3.0	40	
VT3223G13A020			4.0	25	
VT3231G13U020		Rp	1.5	60	
VT3232G13U020			3.0	40	
VT3233G13U020			4.0	25	
VT3251G13A020		SAE	1.5	60	
VT3252G13A020			3.0	40	
VT3253G13A020			4.0	25	
VT3312G13A020		3/4"	Sweat	3.0	40
VT3313G13A020				4.0	25
VT3315G13A020				5.0	20
VT3317G13A020	7.5		17		
VT3322G13A020	NPT		3.0	40	
VT3323G13A020			4.0	25	
VT3325G13A020			5.0	20	
VT3327G13A020	7.5		17		
VT3332G13U020	Rp		3.0	40	
VT3333G13U020			4.0	25	
VT3335G13U020			5.0	20	
VT3337G13U020	7.5		17		
VT3341G13A020	SAE		1.5	60	
VT3342G13A020			3.0	40	
VT3343G13A020			4.0	25	
VT3415G13A020	1"	Sweat	5.0	20	
VT3417G13A020			7.5	17	
VT3427G13A020		NPT	8.0	17	
VT3437G13U020		Rp	8.0	17	
VT3517G13A020	1-1/4"	Sweat	8.0	17	

^a MOPD = Maximum Operating Pressure Differential

TABLE 1. Options Available: Modify model numbers as shown below.

Options	Select
V_ xxxxGx4xxxx	For Steam, use "S".
VT2xxxG_ xxxxx	For Normally Open (2-Way only) use "2".
VTxxxxGxxx_	For Terminal Block with End Switch use "01A".
VTxxxxGxx_ xxx	For Voltage Selection use the following: "A" = 24 Vac, 50/60 Hz "B" = 110 Vac, 50 Hz and 120 Vac, 60 Hz "D" = 208 Vac, 50/60 Hz "T" = 277 Vac, 50/60 Hz "U" = 230Vac, 50 Hz and 240 Vac, 60 Hz.
VTxxxxGxxxxx_	For End Switch use "A".

Note: For complete part number configuration see the Part Numbering System on page 3.



Two Position Spring Return PopTop, Two-Way and Three-Way VT, VS High Close-Off Assemblies



VT/VS Series Valves with High Close-Off Actuator

High Close-Off Valve and Actuator Assemblies					
2-Way Normally Closed					
Catalog Part Number	Size	Type	Cv	MOPD ^a (PSI)	
VT2211H13A020	1/2"	Sweat	1.0	75	
VT2212H13A020			2.5	50	
VT2213H13A020			3.5	30	
VT2221H13A020		NPT	1.0	75	
VT2222H13A020			2.5	50	
VT2223H13A020			3.5	30	
VT2231H13U020		Rp	1.0	75	
VT2232H13U020			2.5	50	
VT2233H13U020			3.5	30	
VT2251H13A020		SAE	1.0	75	
VT2252H13A020			2.5	50	
VT2253H13A020			3.5	30	
VT2312H13A020	3/4"	Sweat	2.5	50	
VT2313H13A020			3.5	30	
VT2315H13A020			5.0	25	
VT2317H13A020		7.5	20		
VT2322H13A020		NPT	2.5	50	
VT2323H13A020			3.5	30	
VT2325H13A020			5.0	25	
VT2327H13A020		7.5	20		
VT2332H13U020		Rp	2.5	50	
VT2333H13U020			3.5	30	
VT2335H13U020			5.0	25	
VT2337H13U020		7.5	20		
VT2341H13A020		Inv. Flare	1.0	75	
VT2342H13A020			2.5	50	
VT2343H13A020			3.5	30	
VT2415H13A020		1"	Sweat	5.0	25
VT2417H13A020				7.5	20
VT2427H13A020			NPT	8.0	20
VT2437H13U020	8.0			20	
VT2517H13A020	1-1/4"	Sweat	8.0	20	

High Close-Off Valve and Actuator Assemblies					
3-Way Normally Closed					
Catalog Part Number	Size	Type	Cv	MOPD ^a (PSI)	
VT3211H13A020	1/2"	Sweat	1.5	75	
VT3212H13A020			3.0	50	
VT3213H13A020			4.0	30	
VT3221H13A020		NPT	1.5	75	
VT3222H13A020			3.0	50	
VT3223H13A020			4.0	30	
VT3231H13U020		Rp	1.5	75	
VT3232H13U020			3.0	50	
VT3233H13U020			4.0	30	
VT3251H13A020		SAE	1.5	75	
VT3252H13A020			3.0	50	
VT3253H13A020			4.0	30	
VT3312H13A020	3/4"	Sweat	3.0	50	
VT3313H13A020			4.0	30	
VT3315H13A020			5.0	25	
VT3317H13A020		7.5	20		
VT3322H13A020		NPT	3.0	50	
VT3323H13A020			4.0	30	
VT3325H13A020			5.0	25	
VT3327H13A020		7.5	20		
VT3332H13U020		Rp	3.0	50	
VT3333H13U020			4.0	30	
VT3335H13U020			5.0	25	
VT3337H13U020		7.5	20		
VT3341H13A020		SAE	1.5	75	
VT3342H13A020			3.0	50	
VT3343H13A020			4.0	30	
VT3415H13A020		1"	Sweat	5.0	25
VT3417H13A020				7.5	20
VT3427H13A020			NPT	8.0	20
VT3437H13U020	8.0			20	
VT3517H13A020	1-1/4"	Sweat	8.0	20	

^a MOPD = Maximum Operating Pressure Differential

TABLE 2. Options Available: Modify model numbers as shown below.

Options	Select
V_xxxxHx4xxxx	For Steam use "S".
VT2xxxH_xxxxx	For Normally Open (2-Way only) use "2".
VTxxxHxxx_	For Terminal Block with End Switch use "01A".
VTxxxHxx_	For Voltage Selection use the following: "A" = 24 Vac, 50/60 Hz "B" = 110 Vac, 50 Hz and 120 Vac, 60 Hz "D" = 208 Vac, 50/60 Hz "T" = 277 Vac, 50/60 Hz "U" = 230Vac, 50 Hz and 240 Vac, 60 Hz.
VTxxxHxxxxx_	For End Switch use "A".

Two Position Zone Valves with Actuators, Spring Return AG, AH Series



Note: For complete part number configuration see the Part Numbering System on page 3.

DIMENSIONAL DATA

Dimensions are in inches (mm).

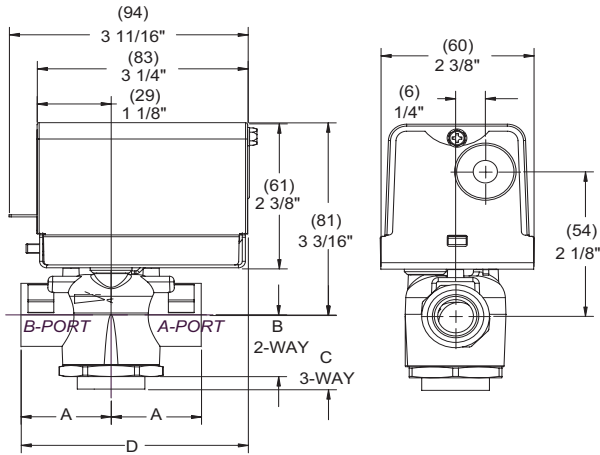

Figure 1 VT/VS Series General Close-off.

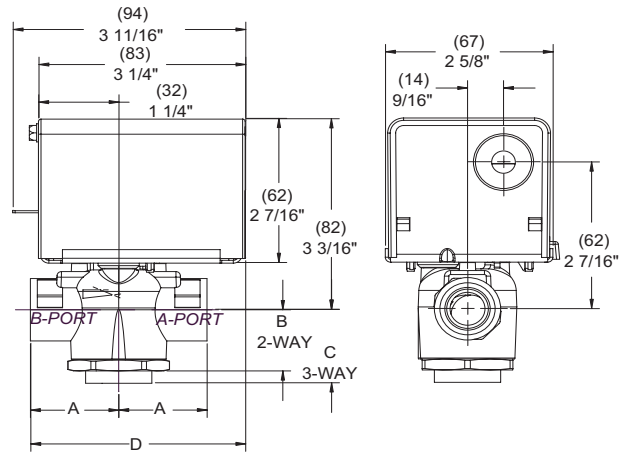

Figure 2 VT/VS Series High Close-off.

TABLE 3. Dimensions - inches (mm).

Valve Body Size	A	B	C	D (General Close-Off)	D (High Close-Off)
1/2" Sweat	1-5/16 (33)	15/16 (23)	1-5/16 (33)	3-5/16 (84)	3-5/8 (92)
3/4" Sweat	1-3/8 (35)	15/16 (23)	1-11/16 (43)	3-3/8 (86)	3-3/4 (95)
1" Sweat	1-11/16 (43)	15/16 (23)	1-11/16 (43)	3-5/8 (92)	4 (102)
1-1/4" Sweat	1-7/8 (47)	1 (25)	1-13/16 (46)	3-11/16 (94)	4-1/8 (105)
1/2" NPT, Rp	1-3/8 (35)	15/16 (23)	1-5/16 (33)	3-3/8 (86)	3-5/8 (92)
3/4" NPT, Rp	1-11/16 (43)	15/16 (23)	1-7/16 (37)	3-5/8 (92)	4 (102)
1" NPT, Rp	1-7/8 (47)	1 (25)	1-11/16 (43)	3-11/16 (94)	4-1/8 (105)
Inverted Flare	See Figure-3 and Figure-4.			4-3/16 (106)	4-7/16 (113)
SAE Flare				See Figure-3 and Figure-4.	

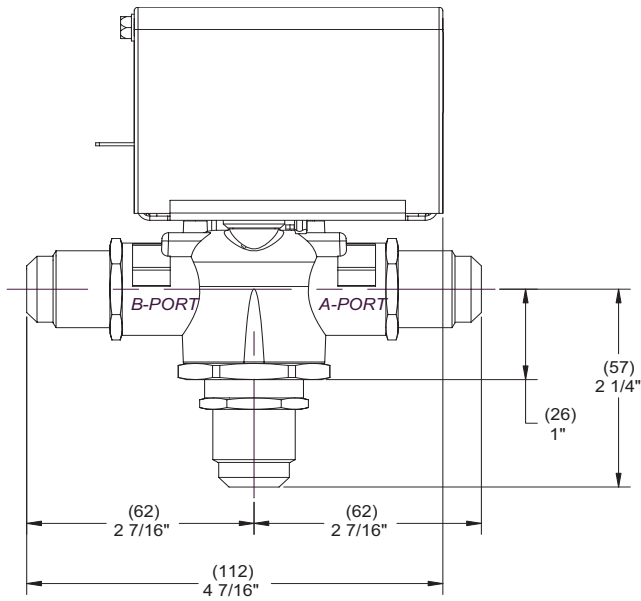

Figure-3 SAE - High Close-Off Style.

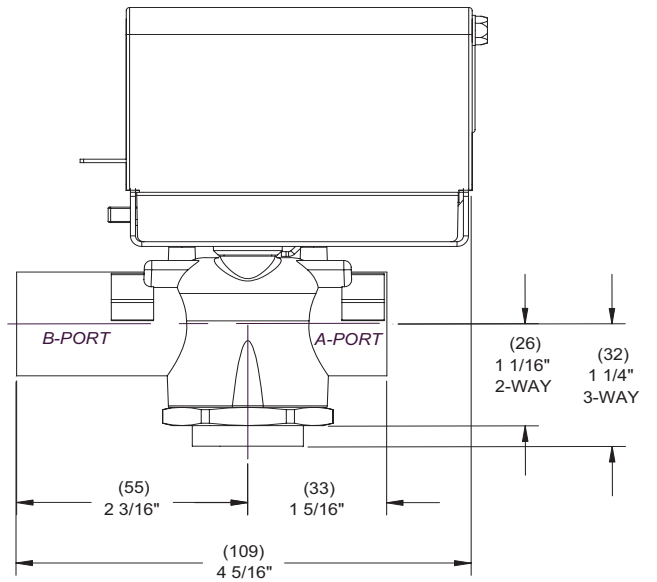

Figure-4 Inverted Flare - General Close-Off Style.

Two Position Zone Valves with Actuators, Spring Return AG, AH Series



Piping

- Three-way valves always require a normally closed actuator.
- Three-way valves are always closed at B port when no power is applied to motor.
- On power up the valve closes to A port on three-way valves.
- Orient three-way valve body as needed for normally open or normally closed flow through coil.

CAUTION: Use in systems which have substantial make-up water (open systems) is not recommended. Follow proper water treatment practices and system procedures. Refer to document F-26080 for Water and Steam EN205 Guidelines.

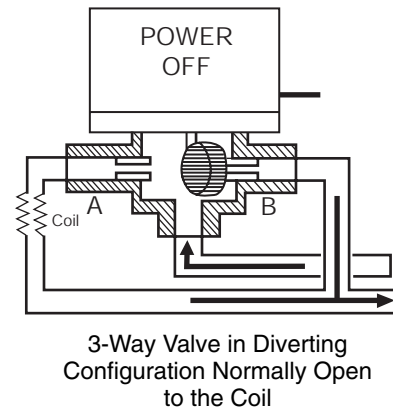
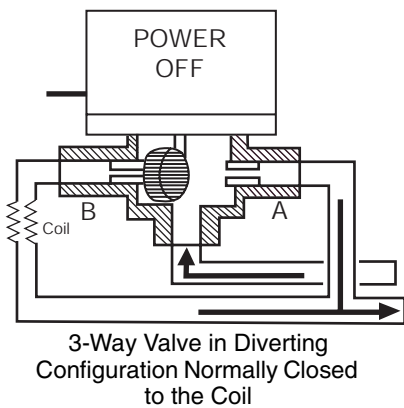
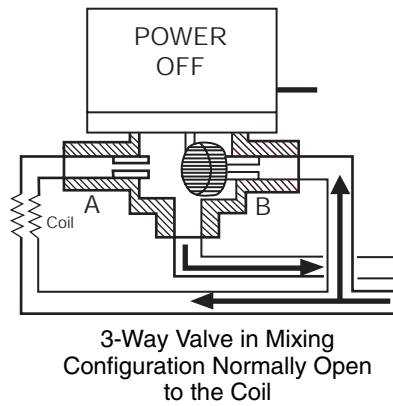
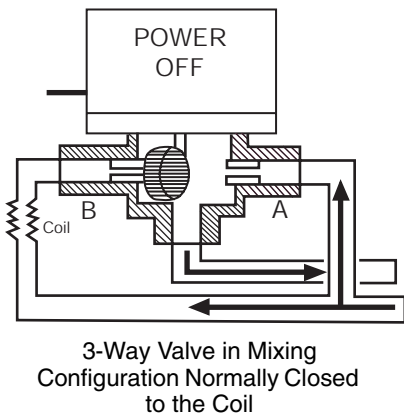
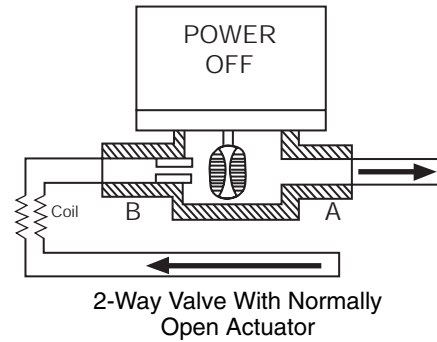
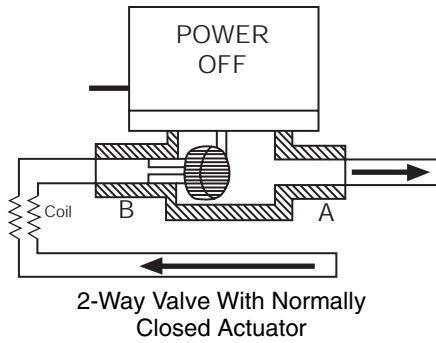

Figure 5 Piping Configurations.

Note: Three-way N.O. applications can be achieved when using a N.C. actuator, by piping the valves in reverse. The three-way examples show normally closed actuators.

Application

The Modulating PopTop™ Series valve actuator assemblies are designed for closed hydronic heating and cooling systems. The Modulating PopTop actuators are used to control fluid flow in fan coil units, VAV reheat, unit ventilators, AHUs and radiant applications.

The Modulating PopTop Proportional (P) type is compatible with any 0 to 10Vdc or 4 to 20 mA signal with jumper selectable operating range and action resulting in precise positioning. The floating (T) type is compatible with any 24 Vac three-wire signal when three minute time-out logic resides in the valve actuator or system controller.

The Modulating PopTop valve assemblies allow the actuator to be snapped onto, or off from, the valve body. The actuator can be mounted after the valve body has been installed into the system without the need for linkages or calibration.

Available in non-spring return and spring return modulating actuators. The two-way spring return modulating actuators are provided in either normally open or normally closed operation. The three-way valves are available in normally closed operation only. Valve body reversal provides normally open flow for three-way valve bodies.



Spring Return Actuator



Non-Spring Return Actuator

Features

- Magnetic clutch to maximize the life of the motor and gear train
- Manual operating lever/position indicator facilitates field setup
- Easy to use terminal blocks
- Actuator can be installed after the valve body
- Three wire floating and 0 to 10 Vdc or 4 to 20 mA proportional available
- Spring will return actuator to normal position when the power is lost

Actuator Specifications

Floating

		Inputs						Outputs			
				Control Circuit, Maximum		Total Actuator, Maximum		Nominal Stroke Time		Elapsed Time Before Time-Out	
Model	Action	VAC	Frequency	mA	VA	mA	VA	60 Hz	50 Hz	60 Hz	50 Hz
AT13A00T	Spring Return	24 Vac +25%/-15%	50/60 Hz	24	0.6	68	1.6	2 min. 30 sec.	3 min.	3 min	3 min
AT23A00T				24	0.6	68	1.6			36 sec	
AT33A000	Non-Spring Return		–	–	40	1.0	NA				
AT33A00T			60 Hz	–	–	50	1.2		NA	3 min ± 30 sec	NA

Modulating

		Inputs					Outputs			
				Control Circuit	Total Actuator, Maximum		Nominal Stroke Time		Elapsed Time Before Time-Out	
Model	Action	VAC	Frequency	Range/ Input Impedance	mA	VA	60 Hz	50 Hz	60 Hz	50 Hz
AP13A000	Spring Return	24 Vac +25%/-15%	50/60 Hz	0-10 ^a VDC/200K 0-5 VDC/200K 5-10 VDC/200K 4-20 mA/300	65	1.6	2 min. 30 sec.	3 min.	2 min. 45 sec.	3 min. 18 sec.
AP23A000										
AP33A000	Non-Spring Return									

^a Factory supplied. Actual range is 1 to 9 Vdc.

Modulating Zone Valve with Actuator, Spring and Non-Spring Return



Specifications Continued

Mechanical: Action, T series: Direct acting. **P series:** Direct acting (valve opens port B with increase in signal.) Field selectable reverse acting.

Manual Override: Allows manual positioning.

Operating Pressure Limits: 300 psi (2068.4 kPa) static pressure.

Material: Actuator: High temperature plastic. **Valve:** body: forged brass; stem: nickel-plated/chrome-plated brass; seat: brass, plug/paddle: high temperature thermoplastic/rubber.

Flow Characteristic: 1.0 to 4.0 Cv: equal percentage. 7.0/8.0 Cv: linear.

Ambient Temperature Limits:

Shipping & Storage, -40 to 158 °F (-40 to 70 °C).

Operating, 32 to 125 °F (0 to 52 °C).

Fluid, 32 to 200 °F (0 to 93 °C) (not steam rated).

Humidity: 5 to 95% RH, non-condensing.

Seat Leakage: ANSI class IV (0.01%).

Agency Listings (Actuator Only): UL873: Underwriters Laboratories (File #E9429 Category Temperature Indicating and Regulating Equipment), Class 2.

CUL: UL Listed for use in Canada by Underwriters Laboratory. Canadian Standards C22.2 No. 24.

European Community: EMC Directive (89/336/EEC)

Australia: This product meets requirements to bear the C-Tick Mark according to the terms specified by the Communications Authority under the Radio Communications Act of 1992.

Shipping Weight (Actuator/Valve Assy.): 1.90 lbs (860 g).

Modulating Zone Valve Spring and Non-Spring Return VM Series Flow Coefficients and Maximum Close-Off Differential Pressure.

Valve Size in.	Connection Type	Flow Coefficient Cv (kv)	Maximum Close-Off ΔP, PSI (kPa)		
			Non-Spring Operating Mode (Driven Closed)	Spring Operating Mode (Driven Closed)	Spring Power Failure Mode ^a (Spring Closed)
1/2	NPT, SW, SAE, and Rp	1.0 (0.9)	50 (344)	50 (344)	50 (344)
1/2	NPT, SW, SAE, and Rp	2.0 (1.8)	50 (344)	50 (344)	20 (137)
3/4	NPT, SW, and Rp				
1/2	NPT, SW, SAE, and Rp	4.0 (3.5)	35 (241)	35 (241)	20 (137)
3/4	NPT, SW, and Rp				
1	SW				
3/4	NPT, SW, and Rp	7.5 (6.5)	35 (241)	35 (241)	15 (103)
1	SW				
1	NPT and Rp	8.0 (6.9)	35 (241)	35 (241)	15 (103)
1-1/4	SW				

Valve Body Legend
NPT — Threaded
SW — Sweat

SAE — Society Automotive Engineers.
Rp — "Metric" Threaded

^a If the valve is driven closed before a power failure, the spring operating mode close-off pressures apply.



Modulating Zone Valve Two-Way and Three-Way VM Series AT, AP Series

Part Numbering System Modulating Spring and Non-Spring Return Zone Valves

△¹ V M X X X X X X 3 A 00 X △²

Body Type
M = Modulating

Configuration
2 = 2-Way
3 = 3-Way

Valve Size
2 = 1/2
3 = 3/4"
4 = 1"
5 = 1-1/4"

Connection Type	Availability
1 = Sweat	1/2", 3/4", 1", 1-1/4"
2 = Threaded NPT	1/2", 3/4", 1"
3 = Threaded Rp (Metric)	1/2", 3/4", 1"
5 = SAE Flare	1/2"

CV Size			
		Size	Connection Type
1 =	1.0	1/2"	1, 2, 3, 5
2 =	2.0	1/2"	1, 2, 3, 5
		3/4"	1, 2, 3
3 =	4.0	1/2"	1, 2, 3, 5
		3/4"	1, 2, 3
		1"	1
7 =	7.5	3/4"	1, 2, 3
		1"	1
	8.0	1"	2, 3
		1-1/4"	1

Actuator Type
T = Three-wire Floating
P = Proportional, 0-10 Vdc, 0-5 Vdc,
5-10 Vdc or 4-20 mA, Jumper Selectable

Options
Non-Spring Return Actuators
0 = No Options
T = Three-Wire Signal Time-Out

Spring Return Actuators
T = Time-Out △³

Electrical Leads
00 = No leads

Voltage
A = 24 Vac Only

Temperature Ratings
3 = General Temperature

Action
1 = Spring Return Normally closed (2-way or 3-way)
2 = Spring Return Normally opened (2-way only)
3 = Non-Spring Return

- △¹ When ordering valve body only: use the first six positions to configure the valve.
- △² When ordering actuator only: use the last seven positions to configure the actuator. Prefix with the letter "A."
- △³ This feature is standard for spring return three wire floating actuators. It must be included in the part number.
- △⁴ Should not be used with thermostats/controllers unless they have a timeout feature.

Available Actuators				
Part Number	Action	Position	Actuator Type	Option
AT13A00T	Spring Return	N.C.	Three Wire Floating	With Time-Out
AT23A00T	Spring Return	N.O.	Three Wire Floating	With Time-Out
AT33A000	Non-Spring Return		Three Wire Floating	None
AT33A00T	Non-Spring Return		Three Wire Floating	With Time-Out
AP13A000	Spring Return	N.C.	Proportional	None
AP23A000	Spring Return	N.O.	Proportional	None
AP33A000	Non-Spring Return		Proportional	None

△⁴

Modulating, Spring and Non-Spring Return PopTop Two-Way and Three-Way VM Assemblies



Two-Way Zone Valve



Three-Way Zone Valve

TABLE 1. PopTop Modulating Valve Model Number Selection Guide.

VM	2	2	1	1
Type	Configuration	Size	Connection	Cv
M = Modulating General Temperature Only	2 = 2-Way 3 = 3-Way	2 = 1/2" 3 = 3/4" 4 = 1" 5 = 1-1/4" (Sweat Only)	1 = Sweat 2 = NPT (female) 3 = Rp (female) 5 = SAE (1/2" only)	1 = 1.0 2 = 2.0 3 = 4.0 7 = 7.5/8.0 (linear)

Catalog Part Number	Fitting Size - in	Type	Cv	
2-Way PopTop™ Modulating Valve Body Only				
VM2211	1/2	Sweat	1.0	
VM2212			2.0	
VM2213			4.0	
VM2221		NPT	1.0	
VM2222			2.0	
VM2223			4.0	
VM2231		Rp	1.0	
VM2232			2.0	
VM2233			4.0	
VM2251		SAE	1.0	
VM2252			2.0	
VM2253			4.0	
VM2312		3/4	Sweat	2.0
VM2313				4.0
VM2317				7.5
VM2322	NPT		2.0	
VM2323			4.0	
VM2327			7.5	
VM2332	Rp		2.0	
VM2333			4.0	
VM2337			7.5	
VM2413	1		Sweat	4.0
VM2417				7.5
VM2427			NPT	8.0
VM2437				
VM2517	1-1/4		Sweat	

Catalog Part Number	Fitting Size - in	Type	Cv	
3-Way PopTop™ Modulating Valve Body Only				
VM3211	1/2	Sweat	1.0	
VM3212			2.0	
VM3213			4.0	
VM3221		NPT	1.0	
VM3222			2.0	
VM3223			4.0	
VM3231		Rp	1.0	
VM3232			2.0	
VM3233			4.0	
VM3251		SAE	1.0	
VM3252			2.0	
VM3253			4.0	
VM3312		3/4	Sweat	2.0
VM3313				4.0
VM3317				7.5
VM3322	NPT		2.0	
VM3323			4.0	
VM3327			7.5	
VM3332	Rp		2.0	
VM3333			4.0	
VM3337			7.5	
VM3413	1		Sweat	4.0
VM3417				7.5
VM3427			NPT	8.0
VM3437				
VM3517	1-1/4		Sweat	

TABLE 2. Options Available: Modify model numbers as shown below.

Options	Select
VMxxx_	For desired Cv enter "1" = 1.0 Cv, "2" = 2.0 Cv, "3" = 4.0 Cv, and "7" = 7.5/8.0 Cv.



Modulating, Spring and Non-Spring Return PopTop Two-Way and Three-Way VM Assemblies



Non-Spring Return Actuator



Spring Return Actuator

TABLE 1. PopTop Modulating Actuator Three Wire floating Model Number Selection Guide.

AT	1	3	A	00	0
Type/Close-Off	Action	Temp	Voltage	Connection	Options
T = Three Wire Floating	1 = Spring Return, Normally Closed 2 = Spring Return, Normally Opened 3 = Non-Spring Return	3 = General	A = 24 V	00 = No Leads	Non-Spring Return Actuator 0 = No Options T = Three Wire Signal Time Out Spring Return Actuator T = Three Wire Signal Time Out

Three Wire Floating, General Temperature, 24 Vac			
Model	Action		Time Out
AT13A00T	Spring Return	Normally Closed	•
AT23A00T		Normally Open	•
AT33A000	Non-Spring Return	—	Must reside in controller
AT33A00T			•

TABLE 2. Floating PopTop Valve and Actuator Assemblies.

PopTop Valve Assembly, Two-Way Spring and Non-Spring Return					
Spring Return, N.C.			Non-Spring Return		
Model No.	Size - inches	Type	Model No.	Size - inches	Type
VM2211T13A00T	1/2	Sweat	VM2211T33A000	1/2	Sweat
VM2221T13A00T		NPT	VM2221T33A000		NPT
VM2231T13A00T		Rp	VM2231T33A000		Rp
VM2251T13A00T		SAE	VM2251T33A000		SAE
VM2312T13A00T	3/4	Sweat	VM2312T33A000	3/4	Sweat
VM2323T13A00T		NPT	VM2322T33A000		NPT
VM2332T13A00T		Rp	VM2332T33A000		Rp
VM2413T13A00T	1	Sweat	VM2413T33A000	1	Sweat
VM2427T13A00T		NPT	VM2427T33A000		NPT
VM2437T13A00T		Rp	VM2437T33A000		Rp
VM2517T13A00T	1-1/4	Sweat	VM2517T33A000	1-1/4	Sweat

PopTop Valve Assembly, Three-Way Spring and Non-Spring Return					
Spring Return, N.C.			Non-Spring Return		
Model No.	Size - inches	Type	Model No.	Size - inches	Type
VM3211T13A00T	1/2	Sweat	VM3211T33A000	1/2	Sweat
VM3231T13A00T		Rp	VM3221T33A000		NPT
VM3221T13A00T		NPT	VM3231T33A000		Rp
VM3251T13A00T		SAE	VM3251T33A000		SAE
VM3312T13A00T	3/4	Sweat	VM3312T33A000	3/4	Sweat
VM3322T13A00T		NPT	VM3322T33A000		NPT
VM3332T13A00T		Rp	VM3332T33A000		Rp
VM3417T13A00T	1	Sweat	VM3413T33A000	1	Sweat
VM3427T13A00T		NPT	VM3427T33A000		NPT
VM3437T13A00T		Rp	VM3437T33A000		Rp
VM3517T13A00T	1-1/4	Sweat	VM3517T33A000	1-1/4	Sweat

Note: For complete part number configuration see the Part Numbering System on page 12.

TABLE 3. Options Available - Modify model numbers as shown below.

Options	Select
VMxxx_Tx3A00x	For desired Cv enter "1" = 1.0 Cv, "2" = 2.0 Cv, "3" = 4.0 Cv, and "7" = 7.5/8.0 Cv.
VMxxxxT_3A00x	For desired action enter: "1" = spring return normally closed, "2" = spring return normally open, "3" = non-spring return.
VMxxxxT33A00_	To add the signal time out enter "T" (only an option on non-spring return).

Modulating Spring and Non-Spring Return PopTop, Two-Way and Three-Way VM Assemblies



Spring Return Actuator



Non-Spring Return Actuator

TABLE 1. PopTop Modulating Actuator Proportional Model Number Selection Guide.

AP	1	3	A	00	0
Type/Close-Off	Action	Temp	Voltage	Connection	Options
P = Proportional ^a	1 = Spring Return, Normally Closed 2 = Spring Return, Normally Opened 3 = Non-Spring Return	3 = General	A = 24 V	00 = No Leads	0 = No Options

^a Factory shipped as 0 to 10 Vdc. Jumper selectable, 0 to 5 Vdc, 5 to 10 Vdc, or 4 to 20 mA.

Modulating, General Temperature, 24 Vac			
Model	Action		Time Out
AP13A000	Spring Return	Normally Closed	Does not apply
AP23A000		Normally Open	
AP33A000	Non-Spring Return	—	

TABLE 2. Proportional PopTop Valve and Actuator Assemblies.

PopTop Valve Assembly, Modulating Two-Way Spring and Non-Spring Return					
Spring Return, N.C.			Non-Spring Return		
Model No.	Size - inches	Type	Model No.	Size - inches	Type
VM2211P13A000	1/2	Sweat	VM2211P33A000	1/2	Sweat
VM2221P13A000		NPT	VM2221P33A000		NPT
VM2231P13A000		Rp	VM2231P33A000		Rp
VM2251P13A000		SAE	VM2251P33A000		SAE
VM2312P13A000	3/4	Sweat	VM2312P33A000	3/4	Sweat
VM2322P13A000		NPT	VM2322P33A000		NPT
VM2332P13A000		Rp	VM2332P33A000		Rp
VM2413P13A000	1	Sweat	VM2413P33A000	1	Sweat
VM2427P13A000		NPT	VM2427P33A000		NPT
VM2437P13A000		Rp	VM2437P33A000		Rp
VM2517P13A000	1-1/4	Sweat	VM2517P33A000	1-1/4	Sweat

PopTop Valve Assembly, Modulating Three-Way Spring and Non-Spring Return					
Spring Return, N.C.			Non-Spring Return		
Model No.	Size - inches	Type	Model No.	Size - inches	Type
VM3211P13A000	1/2	Sweat	VM3211P33A000	1/2	Sweat
VM3221P13A000		NPT	VM3221P33A000		NPT
VM3231P13A000		Rp	VM3231P33A000		Rp
VM3251P13A000		SAE	VM3251P33A000		SAE
VM3312P13A000	3/4	Sweat	VM3312P33A000	3/4	Sweat
VM3322P13A000		NPT	VM3322P33A000		NPT
VM3332P13A000		Rp	VM3332P33A000		Rp
VM3413P13A000	1	Sweat	VM3413P33A000	1	Sweat
VM3427P13A000		NPT	VM3427P33A000		NPT
VM3437P13A000		Rp	VM3437P33A000		Rp
VM3517P13A000	1-1/4	Sweat	VM3517P33A000	1-1/4	Sweat

TABLE 3. Options Available – Modify model numbers as shown below.

Options	Select
VMxxx_Px3A000	For desired Cv enter “1” = 1.0 Cv, “2” = 2.0 Cv, “3” = 4.0 Cv, and “7” = 7.5/8.0 Cv.
VMxxxxP_3A000	For desired action enter: “1” = spring return normally closed, “2” = spring return normally open, “3” = non-spring return.

DIMENSIONAL DATA

Dimensions shown in inches (mm).

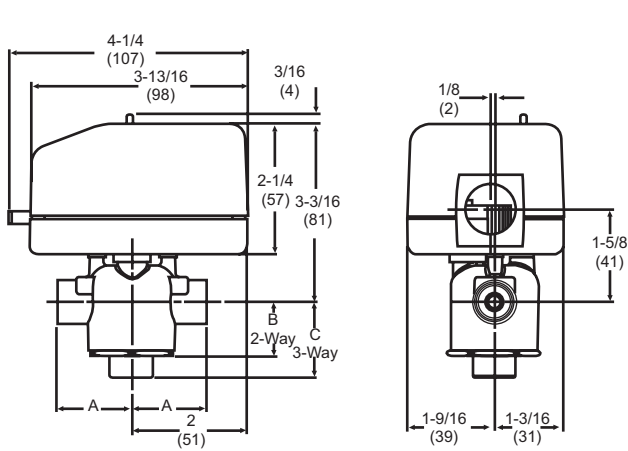

Figure 1 Modulating Non-Spring Return Valve.

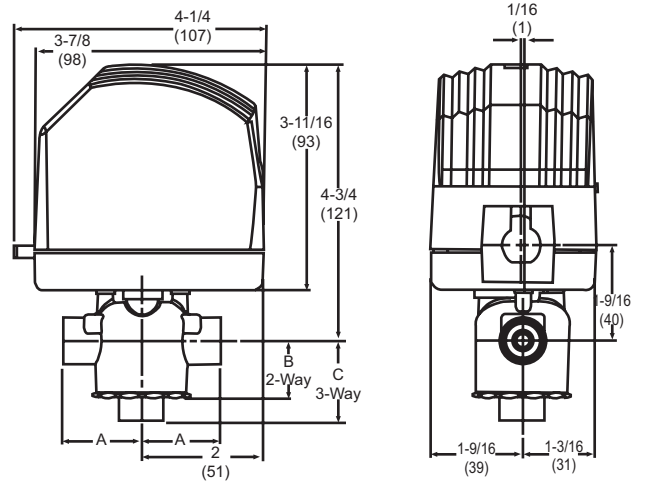

Figure 2 Modulating Spring Return Valve.

TABLE 4. Dimensions - inches (mm) .

Valve Body Size	A	B	C
1/2" Sweat	1-5/16 (33)	15/16 (23)	1-5/16 (33)
3/4" Sweat	1-3/8 (35)	15/16 (23)	1-11/16 (43)
1" Sweat	1-11/16 (43)	15/16 (23)	1-11/16 (43)
1-1/4" Sweat	1-7/8 (47)	1 (25)	1-13/16 (46)
1/2" NPT, Rp	1-3/8 (35)	15/16 (23)	1-5/16 (33)
3/4" NPT, Rp	1-11/16 (43)	15/16 (23)	1-7/16 (37)
1" NPT, Rp	1-7/8 (47)	1 (25)	1-11/16 (43)
1/2" SAE Flare	See Figure-3.		

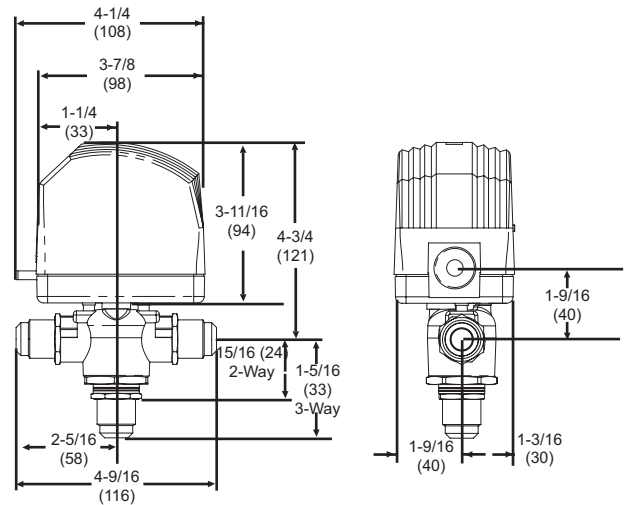

Figure 3 1/2" SAE.

Modulating Spring and Non-Spring Return PopTop, Two-Way and Three-Way VM Assemblies

Piping

- The 3-way is only configured as normally closed. For normally open configuration to the coil turn valve around. For proportional valves, set the control action (direct or reverse accordingly).
- The valve should be used in a closed loop system.
- All valves must be piped so that the plug closes against the direction of flow. For two-way valves, flow is from port B to port A. For normally closed three-way valves, B is the service port and A is the bypass port. For normally open three-way valves, A is the service port and B is the bypass port.
- Three-way VM valves must be piped in a mixing configuration, not diverting.

CAUTION: Do not use VM series valves in "open" systems. Excess make-up water may cause damage to the valve. Follow proper water treatment practices and system procedures. Refer to document F-26080; EN205, *Water and Steam System Guidelines*.

Note: Normally open actuators are not to be used on 3-way valves to achieve normally open configurations. Use a normally closed actuator and pipe as shown in Figure-5.

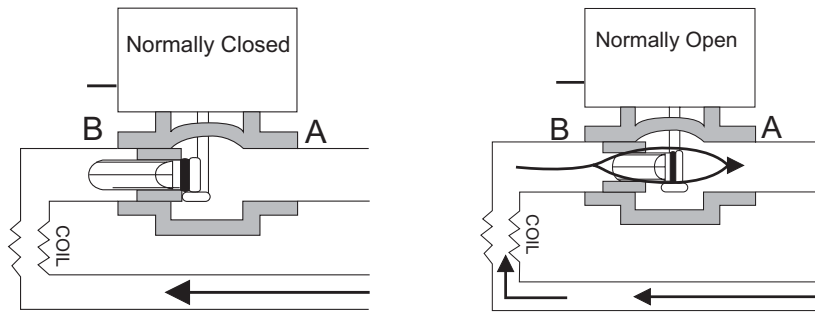

Figure 4 Two-Way Spring Return Valves.

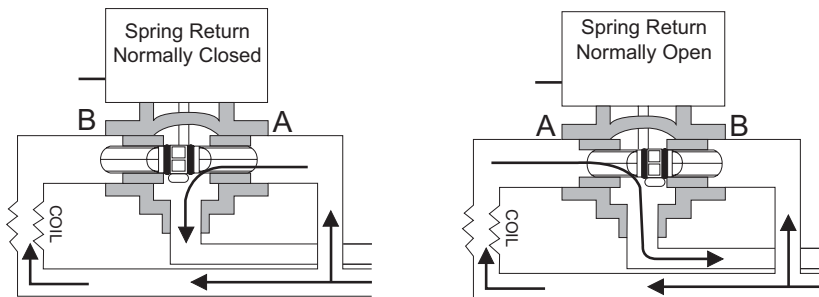

Figure 5 Three-Way Spring Return Valves.



Two Position Damper Actuator Direct and Linkage Drive 453X Series

Application

The 453L and 453H damper actuators are designed for a variety of two-position, spring return, damper applications. These actuators feature a hysteresis synchronous motor designed for long life with a unique "lost motion" mechanism to protect the gear train from closing shock.

The 453L and 453H use a simple 2-wire thermostat control, and are available with an optional end switch.

Features

- Clockwise or counterclockwise rotation
- Linkage and direct drive models
- Auxiliary switch (optional)

Actuator Specifications

Voltage: 24 Vac @ 50/60 Hz., 110 Vac @ 50 Hz. and 120 Vac @ 60 Hz., 220 Vac @ 50 Hz. and 230 Vac @ 60 Hz.

Power Requirements: See Table-1 Model Chart.

Connections: Internal junction box, 18 inch leads, cord sets.

Optional End Switch: 10 amps @ 125-250 Vac; 1/3 hp @ 125-250 Vac.

Direction of Rotation: CW or CCW rotation is available.

Direct Drive: For 5/16" maximum damper output shaft with maximum engagement of 7/8".

Ambient Temperature Limits:

Shipping & Storage,
-40 °F to 160 °F (-40 to 71 °C).

Operating,
0 ° to 120 °F (-18 to 49 °C).

Humidity: Non-condensing.

Agency Listings: CE Mark compliant. UL and CUL recognized for 453L and 453H (File Number E9429).

Shipping Weight: 453L and 453H: 1.2 lbs (544 g).

Location: NEMA 1.

Accessories

453-52	6 to 12 in damper shaft kit
453-69	12 to 20 in damper shaft kit
453-239	Damper shaft adapter converts direct coupled shafts from 5/16" to 1/2".
30-145-A	Damper Actuator Replacement Motor (H only) Class "A" Rated Temperature 120°F ambient, 24 Vac, 50/60 Hz.
30-145-B	Damper Actuator Replacement Motor (H only) Class "A" Rated Temperature 120 °F ambient, 110 Vac @ 50 Hz. and 120 Vac @ 60 Hz.
30-145-U	Damper Actuator Replacement Motor (H only) Class "A" Rated Temperature 120°F ambient, 220 Vac @ 50 Hz. and 230 Vac @ 60 Hz.



**Direct Drive
453X Actuator**



**Linkage Drive
453X Actuator**

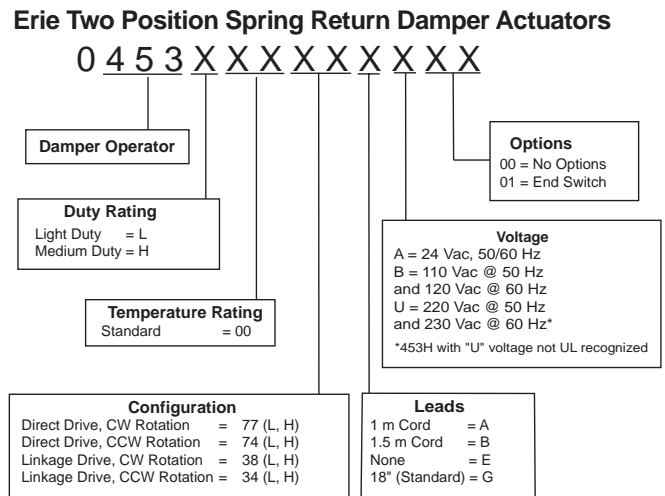

Figure 1 Selection Chart.

Two Position Damper Actuator Direct and Linkage Drive 453X Series



TABLE 1. Model Chart

Model Number	Torque Rating in-oz.				Power		Stroke Speed in Seconds	
	Motor Driven		Spring Return		W	VA	Motor Driven	Spring Return
	0°	84°	0°	84°				
453L	45	25	17	25	6.5	7.5	18 @ 60 HZ 22 @ 50 Hz	6
453H	55	35	35	55	6.5	10	27 @ 60 Hz 32 @ 50 Hz	8



Direct Drive
453X Actuator



Linkage Drive
453X Actuator

TABLE 1. Light Duty, Two Position, Spring Return Model Number Selection Guide.

NOTE: For complete part number configuration, see Part Numbering System in Figure 1.

Catalog Part Number	Voltage - Vac	Rotation	End Switch
Direct Drive			
0453L0074GA00	24	CCW	
0453L0074GB00	120		
0453L0074GU00	230		
0453L0077GA00	24	CW	
0453L0077GA01			•
0453L0077GB00			120
0453L0077GB01	•		
0453L0077GU00	230		
0453L0077GU01			•

Catalog Part Number	Voltage - Vac	Rotation	End Switch
Linkage Drive			
0453L0034GA00	24	CCW	
0453L0034GB00	120		
0453L0034GU00	230		
0453L0038GA00	24	CW	
0453L0038GA01			•
0453L0038GB00			120
0453L0038GB01	•		
0453L0038GU00	230		
0453L0038GU01			•

TABLE 2. Medium Duty, Two Position, Spring Return Model Number Selection Guide.

Catalog Part Number	Voltage - Vac	Rotation	End Switch
Direct Drive			
0453H0074GA00	24	CCW	
0453H0074GB00	120		
0453H0074GU00	230		
0453H0077GA00	24	CW	
0453H0077GA01			•
0453H0077GB00			120
0453H0077GB01	•		
0453H0077GU00	230		
0453H0077GU01			•

Catalog Part Number	Voltage - Vac	Rotation	End Switch
Linkage Drive			
0453H0034GA00	24	CCW	
0453H0034GB00	120		
0453H0034GU00	230		
0453H0038GA00	24	CW	
0453H0038GA01			•
0453H0038GB00			120
0453H0038GB01	•		
0453H0038GU00	230		
0453H0038GU01			•

Application

The 453R damper actuators are designed for two-position, motor open and motor closed, damper applications.

The 453R actuator features a reversible hysteresis synchronous motor which requires a maintained voltage to either the opening or closing side to hold position.

The 453R uses a simple 3-wire control. The 453R is suitable for up to 500 in² (3,225 cm²) of balanced damper.



Direct Drive 453 Actuator

Features

- 24 Vac, 120 Vac, and 230 Vac models available
- Motor open/motor closed

Actuator Specifications

Voltage: 24 Vac @ 60 Hz., 110 Vac @ 50 Hz. and 120 Vac @ 60 Hz., 220 Vac @ 50 Hz. and 230 Vac @ 60 Hz.

Power Requirements: See Table-1 Model Chart.

Connections: Internal junction box, 18 inch leads.

Direct Drive: For 5/16" maximum damper output shaft with maximum engagement of 7/8".

Ambient Temperature Limits:

Shipping & Storage,

-40 to 160 °F (-40 to 71 °C).

Operating,

0 to 120 °F (-18 to 49 °C).

Humidity: Non-condensing.

Agency Listings: None.

Shipping Weight: 453R: 1.7 lbs (71 g).

Location: NEMA 1.

Accessories

- | | |
|---------|---|
| 453-52 | 6 to 12 in damper shaft kit |
| 453-69 | 12 to 20 in damper shaft kit |
| 453-239 | Damper shaft adapter converts direct coupled shafts from 5/16" to 1/2". |

Erie Two Position Damper Actuators

0 4 5 3 R X X X X X X X X X

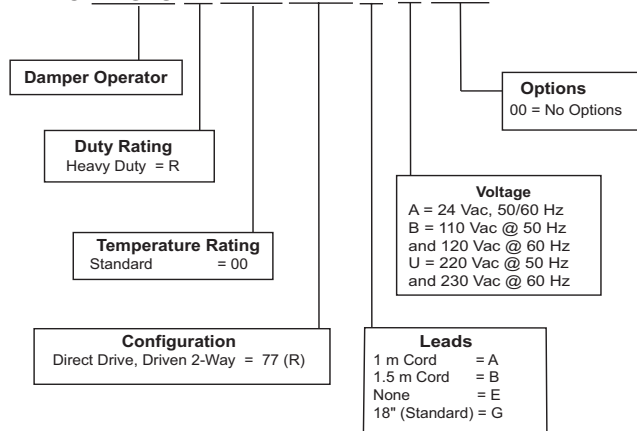

Figure 1 Selection Chart.

TABLE 1. Model Chart

Model Number	Torque Rating in-oz.				Power		Stroke Speed in Seconds
	Motor Driven		Spring Return		W	VA	Motor Driven
	0°	84°	0°	84°			
453R	100	100	NA	NA	6.5	7.5	37 @ 60 Hz 45 @ 50 Hz

TABLE 2. Heavy Duty, Two Position, Motor Open/Motor Closed Model Number Selection Guide.

Catalog Part Number	Voltage - Vac
Direct Drive	
0453R0077GA00	24
0453R0077GB00	120
0453R0077GU00	230

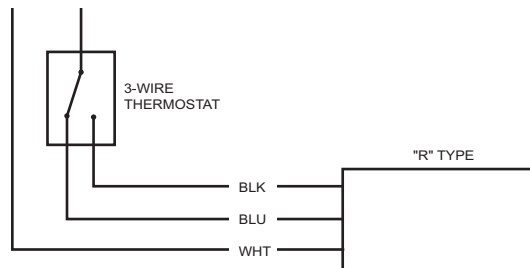

Figure 2 Wiring with 3-Wire Thermostat (18" Leads).

**Two Position Heavy Duty Damper
Actuator**



453R

Application

This valve actuator is an air-immersed, non-spring return actuator compatible with floating DDC controllers.

Features

- Floating actuator controlled by SPDT floating controller (drive open-hold-drive closed) or a DDC controller with equivalent control action (contact or triac).
- Optional control module cards for proportional control (MF-63123 only): MFC-8000 for Vdc and MFC-420 for 4 to 20 mAdc.
- 210 lbs minimum output force with automatic load limit.
- Wide operating ambient range of 0 to 140 °F (-18 to 60 °C).
- Synchronous motor assures accurate stroke timing.
- MF-63123 series available with position feedback potentiometer.
- Self-adjusting travel and position feedback potentiometer mechanisms.
- Manual override operation with automatic release.
- Adjustable SPDT auxiliary switch on -500 models.
- Rugged construction: Die cast housing, double thread 1/2 in. dia. stainless steel jackscrew, roller thrust bearings, and all metal gear train.
- Integral linkage for 1/2 to 2 in. VB-7XXX valves. Optional linkage for 2-1/2 to 4 in. VB-9XXX valves.



Model Chart

Model No.	Actuator Power Input				Feedback 15K W Pot.	Aux. Switch
	Voltage (+10%/ -15%)	Hz	Amps	Watts		
MF-63103	24 Vac	50/60	0.25	7	No	No
MF-63103-500						Yes
MF-63123 ^a					Yes	No
MF-63123-500 ^a						Yes

^a Feedback potentiometer cannot be used when MFC control module card is installed

Floating Valve Actuator MF-631X3 Series



Specifications

Inputs	
Control signal	SPDT floating control contacts or 2 SPDT control contacts: Minimum rating of 1 amp at 24 Vac inductive load. Triacs: DDC controller must be able to switch 1 amp inductive load (200 Vac minimum).
Power	Refer to Model Chart.
Connections	Coded screw terminals.
Electrical	Auxiliary switch (-500 models): SPDT, adjustable over actuator stroke of 1 in. The N.C. contact is factory set to make contact at 3/8 in. from the fully extended position. Rating: 1 amp at 24 Vac, 50/60 Hz. Pilot duty rating; 24 VA at 24 Vac. Connections: Color coded leads for auxiliary switch, terminal block for control.
Position feedback signal	Refer to Model Chart (cannot be used when MFC control module card is installed). Connections: Coded screw terminals.
Mechanical	Force: 210 lbs (935 N) minimum and 270 lbs (1202 N) maximum with automatic load limit. Stroke: Up to maximum of 1 in. self adjusting. Timing: 2 minutes per in. at 60 Hz; 2 minutes, 24 seconds per in. at 50 Hz.
Environment	
Ambient temperature limits	Shipping and storage: -40 to 160 °F (-20 to 71 °C). Operating: 0 to 140 °F (-18 to 60 °C). Refer to Valve section for further information.
Humidity	5 to 95% RH, non-condensing.
Locations	NEMA Type 1.
Dimensions	5-7/8 H x 5-5/8 W x 3-5/8 D in. (149 x 143 x 92 mm).

Accessories

Model No.
MFC-420
MFC-8000
Valve Linkage
AV-672
AV-673
AV-674

Description
Control module card for 4 to 20 mAdc (for MF-63123 only, order separately).
Control module card for Vdc (for MF-63123 only, order separately).

Linkage for 2-1/2 to 4 in. VB-9000 valves, except VB-9323 (order separately).
Linkage for 1/2 to 2 in. Johnson Controls VB-3754, VB-3924, and VB-4324 valves.
Linkage for 1/2 to 3 in. Honeywell V5011F, V5011G, and V5013F valves.

Typical Applications

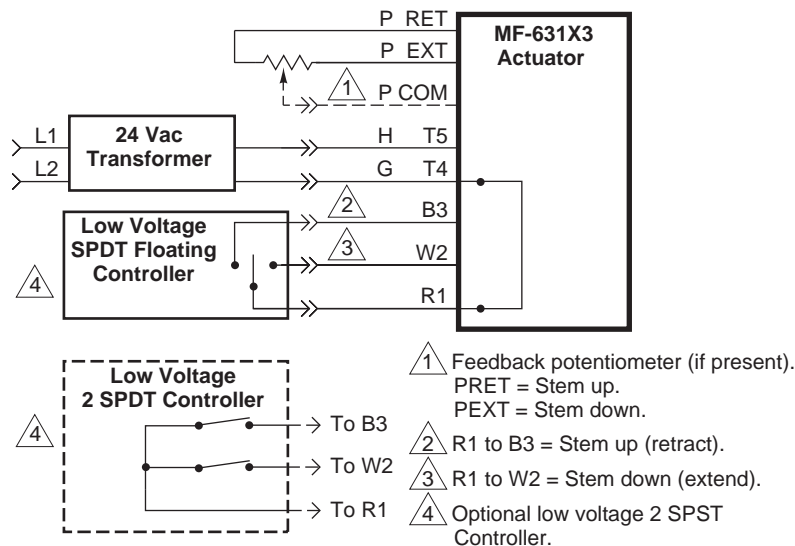

Figure 1 Basic Actuator: Wiring Diagram with SPDT Floating Controller.

Application

This Control Module Card is designed as a plug-in module for the MF-63123 Floating Valve Actuator. The MFC-420 card allows the actuator to accept proportional mAdc signals.

Features

- Acceptance of all commonly used proportional mAdc input signals.
- Factory set for 4 to 20 mAdc applications.
- Switch selectable control input signal extend point and span for quick, accurate field setup.
- Control module plugs into MF-63123 actuator for quick, easy installation.
- Field selectable 100 Ω or 250 Ω impedance.

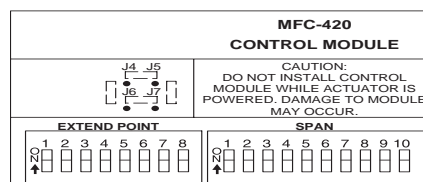
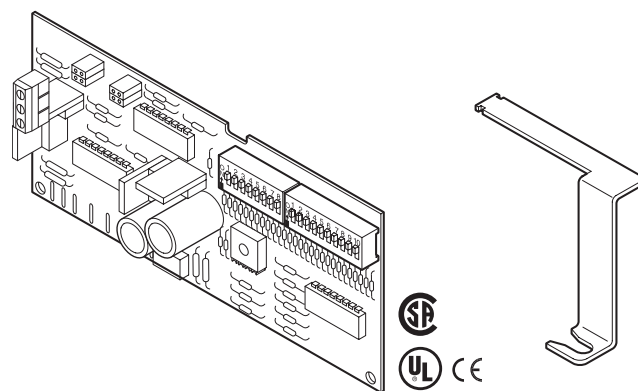

Model Chart

Model No.	Power Input				Actuator Part Number	
	Voltage (+20%/-15%)	Hz	Amps	Watts		
MFC-420	24 (Class 2 Power Supply)	50	N/A	0.085	1.2	MF-63123
		N/A	60	0.080	1.1	MF-63123-500

Specifications

Inputs	
Control signal	Factory setting: 4 to 20 mAdc.
	Maximum input signal: 25 mAdc to maintain specified performance.
	Operating span: 4 to 16 mAdc adjustable by DIP switch.
	Start point: 2 to 16 mAdc adjustable by DIP switch.
	Hysteresis: factory setting, 2.1% of span (16 mAdc control signal input span). Hysteresis is switch selectable using positions 9 and 10 of the 10 position DIP switch.
Power requirements	Refer to Model Chart.
Connections	Control module to actuator: Uses the pin connections on the actuator circuit board to interface with control module.
	Field wiring for control signal: Uses the screw terminals on the circuit board and accepts 14 to 20 gage wire.
Outputs	
Electrical	Control module plugs into MF-63123 Actuator.
Timing	Refer to MF-63123 Actuator General Instructions, F-24732.
Ambient temperature limits	Shipping and storage: -40 to 160 °F (-40 to 71 °C). Operating: 0 to 140 °F (-17.78 to 60 °C).
Humidity	5 to 95% RH, non-condensing.
Locations	NEMA Type 1 (when mounted in MF-63123).
Dimensions	1-7/8 H x 4-9/16 W x 4/5 D in. (47.6 x 115.9 x 20.6 mm).

Application

This card acts as a plug-in module for the MF-63123 Floating Valve Actuator. It allows the actuator to accept proportional voltage Vdc signals.

Features

- Acceptance of all commonly used proportional Vdc input signals (0 to 10 Vdc and 6 to 9 Vdc).
- Factory set at 6 to 9 Vdc for System 8000 applications.
- Switch-selectable control input signal extend point and span for quick, accurate field setup.
- MF-63123 actuator plug-in for quick, easy installation.
- Field-selectable for direct or reverse action, for maximum application flexibility.

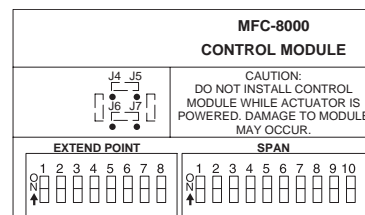
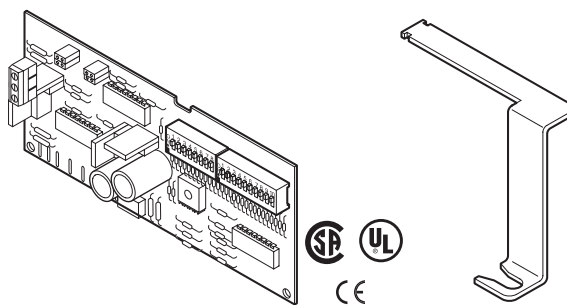

Model Chart

Model No.	Power Input				Actuator Part Number
	Voltage (+20%/ -15%)	Hz	Amps	Watts	
MFC-8000	24 (Class 2 Power Supply)	50	0.085	1.2	MF-63123
		60	0.080	1.1	MF-63123-500

Specifications

Inputs	
	Factory setting: 6 to 9 Vdc.
	Maximum input signal: 22 Vdc to maintain specified performance. 30 Vdc to avoid component damage.
	Operating span: 2 to 10 Vdc adjustable by DIP switch.
Control signal	Start point: 0 to 12 Vdc adjustable by DIP switch.
	Hysteresis: Hysteresis switch settings selectable using 9 and 10 of the 10-position DIP switch. Refer to General Instructions. Factory setting: 2.3% of span (3 Vdc control signal input span). Adjustable: hysteresis switch selection settings for control signal input spans. Refer to General Instructions.
	Impedance: Minimum of 10k Ω .
Power required	Refer to Model Chart.
Connections	Control module to actuator: Uses the pin connections on the actuator circuit board to interface with control module.
	Field wiring for control signal: Uses the screw terminals on the circuit board and accepts 14 to 20 gage wire.
Outputs	
Electrical	Control module plugs into MF-63123 Actuator.
Timing	Refer to MF-63123 Actuator General Instructions, F-24732.
Ambient temperature limits	Shipping and storage: -40 to 160 °F (-40 to 71 °C). Operating: 0 to 140 °F (-17.78 to 60 °C).
Humidity	5 to 95% RH, non-condensing.
Locations	NEMA Type 1 (When mounted in MF-63123).
Dimensions	1-7/8 H x 4-9/16 L x 4-13/16 D in. (47.6 x 115.9 x 20.6 mm).

Typical Applications

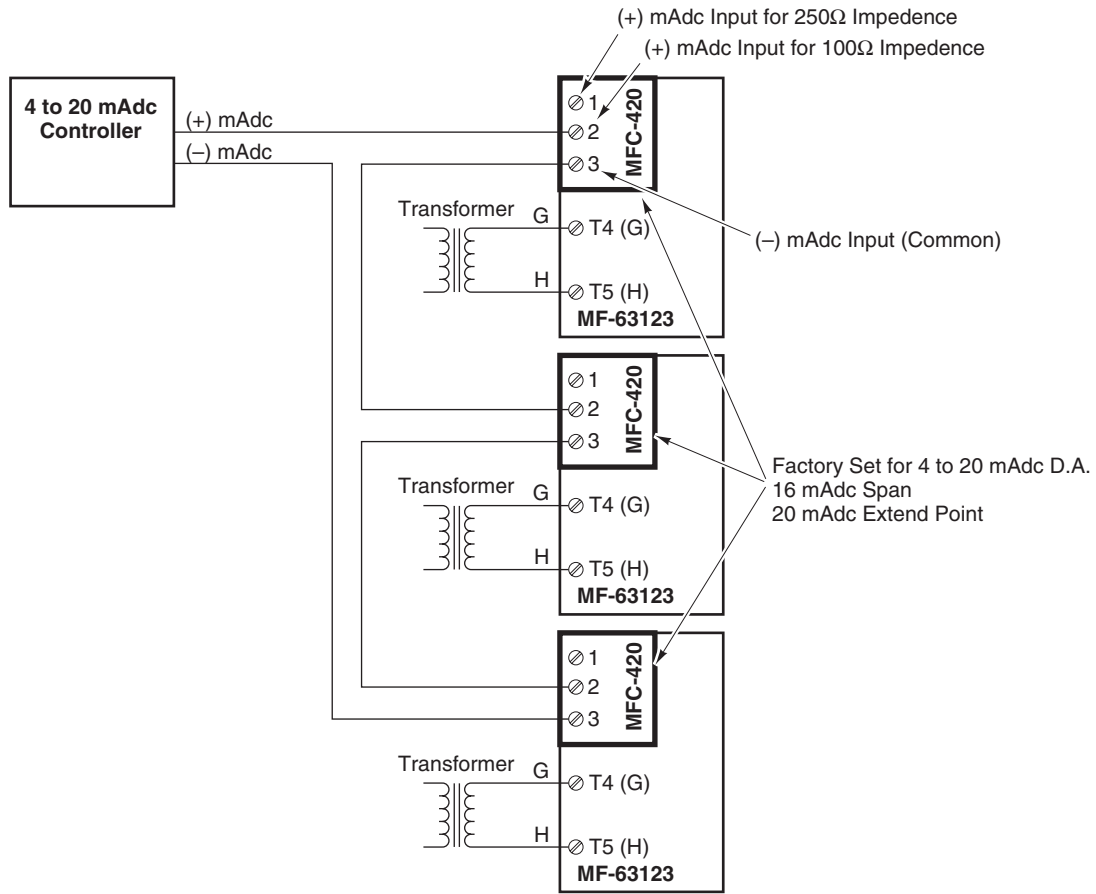

Figure 1 Switch and Adjustment Locations. Showing Wiring Designations, Typical Factory Switch and Shorting Block Settings.

Typical Applications

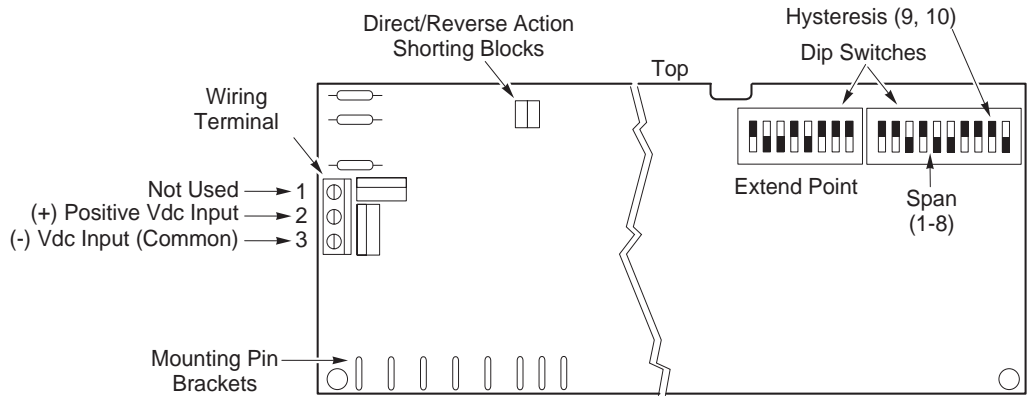

Figure 1 Switch and Adjustment Locations Showing Wiring Designations, Typical Factory Switch, and Shorting Block Settings.

Application

The MP Series Actuators are used for two-position, floating, and proportional control of dampers, valves, and program switches in heating, ventilation, and air conditioning applications or similar applications.

Features

- Proportional actuators with built-in feedback potentiometers.
- Spring return and non-spring return models available.
- 24 Vac models.
- Die cast housings with four 1/2 in. conduit openings.
- Oil-immersed motor and gear train.



MP-361



MP-371



MP-381

Model Chart

MP-3XX Series.

Model No.	Application	Solid State Drive CP-9301 CP-9302	Power Requirements			Output Shaft				Aux. Switch
			Volts	Hz	Amps	Torque lb.-in. (N-m)	Timing Seconds (No Load)	Degrees of Rotation	Spring Return	
MP-361	Proportional	Available	24	60	2.5	50 (5.6)	90	180 (Adj. ^a)	CW	SPDT
MP-361-691 ^b		CP-9301 Included								
MP-361-692 ^c		CP-9302 Included								
MP-371		Available						180 (Non Adj.)	CCW	
MP-371-691 ^b		CP-9301 Included								
MP-371-692 ^c		CP-9302 Included								
MP-381		Available				220 (24.9)	130	180 (Adj. ^a)	∅	
MP-381-691 ^b		CP-9301 Included								
MP-381-692 ^c		CP-9302 Included								

^a Rotation adjustable 45 to 320°. Caution: On actuators with proportional input signals changing the rotation will affect the control, since the internal feedback potentiometer's travel is fixed.

^b Integral solid state drive CP-9301 accepts 6 to 9 Vdc voltage. May be field calibrated for other ranges, including 4 to 20 mAdc.

^c Integral solid state drive CP-9302 accepts 4 to 20 mAdc voltage. May be field calibrated for other ranges, including 6 to 9 or 2 to 10 Vdc.

Reversible and Proportional Electric Actuators

MP-3XX Series



Specifications

Input Control signals	Refer to the Model Charts for input control signal capability versus specific actuator models.
Floating	Requires one Single Pole Double Throw (SPDT) switch with floating (center off) position rated at 0.9 amps at 24 Vac or two Single Pole Single Throw (SPST) switches rated at 0.9 amps at 24 Vac.
Two-position	SPDT: Requires snap acting switch rated at 0.9 amps at 24 Vac. SPST: Can be used with certain spring return actuators. Switch must be rated to handle actuator power requirements.
Proportional	Requires CP-930X-XXX Series solid state actuator drives. Refer to the Model Charts.
Solid State Drives	CP-9301: Vdc or mAdc factory set for 6 to 9 Vdc (System 8000). CP-9302: Vdc or mAdc factory set for 4 to 20 mAdc (also has input signal override feature).
Connections	
MP-3XX	Coded screw terminals.
Models -69X Suffix	Coded screw terminals except for input signal which are color coded pigtailed.
Power Requirements	Refer to the Model Charts to determine power requirements.
Torque	Refer to the Model Charts to determine the actuator torque rating.
Nominal damper area	Actuator sizing should be done in accordance with damper manufacturer's specifications.
Spring return	Refer to the Model Charts for models that are spring return.
Environment	
Ambient temperature limits	Shipping and storage: -40 to 160 °F (-40 to 71 °C). Operating: -40 to 136 °F (-40 to 58 °C).
Humidity	5 to 95% RH, non-condensing.
Locations	NEMA 1. NEMA 4 for non-spring return actuators with AM-363.
Dimensions	
MP-3XX	7 H x 5-3/8 W x 6-5/16 D in. (178 x 136 x 160 mm).
Models -691 Suffix	7 H x 5-3/8 W x 8-1/8 D in. (178 x 136 x 206 mm).

Accessories

Model No.	Description
Valve linkage for 50 lb.-in. minimum, 180° actuator.	
AV-391	Valve linkage for 1/2 to 2 in. VB-7XXX and 1/2 to 1-1/4 in. obsolete VB-9XXX.
AV-395	Valve linkage for 2-1/2 to 4 in. VB-9213 or VB-9313.
Valve linkage for 130 lb.-in. minimum, 180° actuator.	
AV-352	Valve linkage for 2-1/2 to 6 in. VB-9213 or VB-9313, 4 to 6 in. VB-9323.
AV-393	Valve linkage for 1/2 to 2 in. VB-7XXX and 1/2 to 1-1/4 in. obsolete VB-9XXX.
AV-396	Valve linkage for 2-1/2 to 4 in. VB-9213 or VB-9313.

Typical Applications

- ① Terminals 1,5, & 6 are used for built-in auxiliary switch.
- ② Rotates CW or Closes Valve (Lowers Stem).
- ③ Rotates CCW or Opens Valve (Raises Stem).
- ④ These terminal are marked L1 & L2 on line voltage actuators.
- ⑤ Remove green wire to unground actuator.
- ⑥ SPDT Neutral Off Switch may be used on manual positioning applications.
- ⑦ Switch control circuit is 0.5 amp at approx. 24 Vac on either low or line voltage actuators.
- ⑧ Install under cover of actuator.

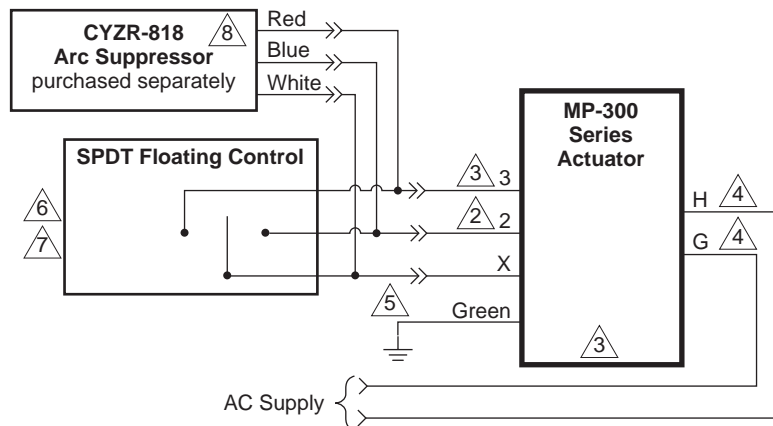
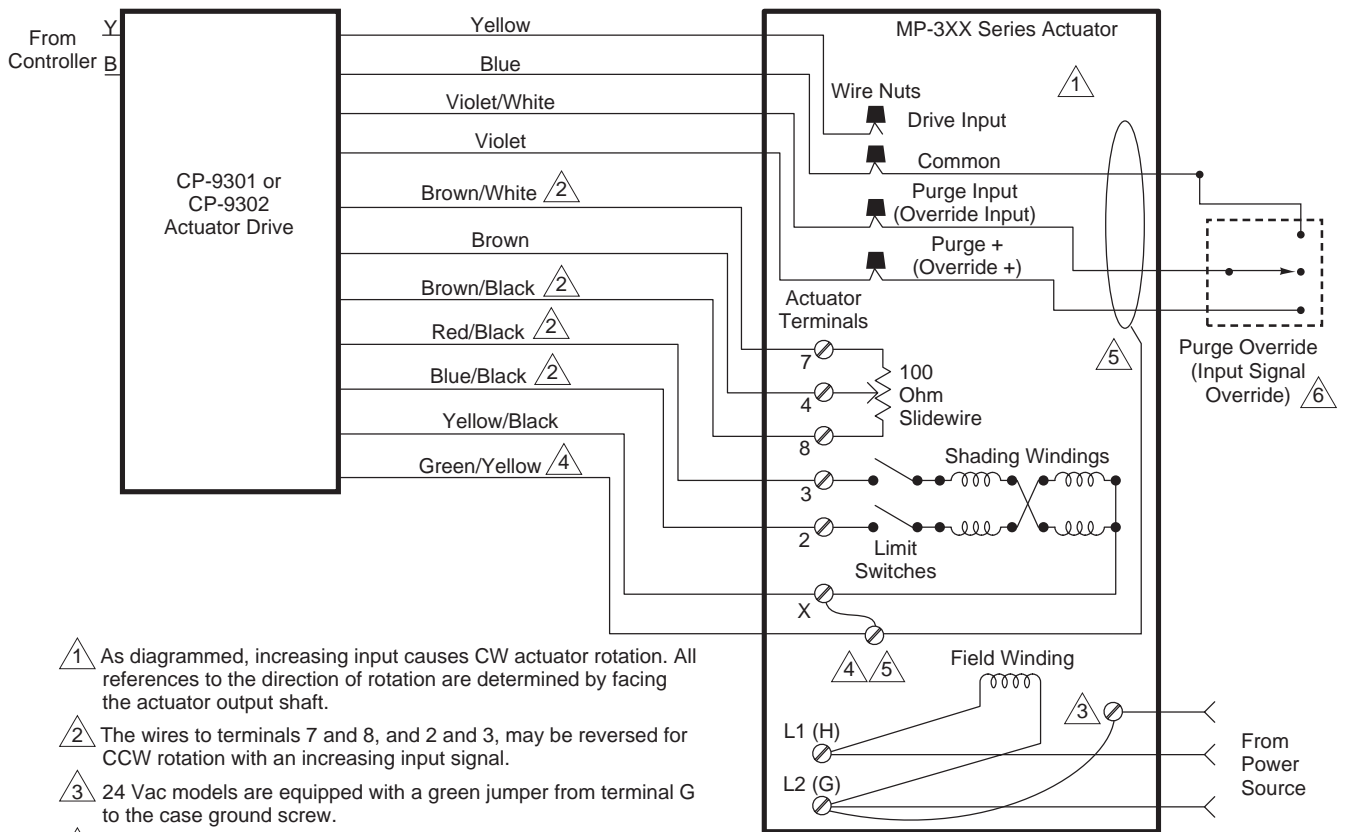

Figure 1 Reversible Floating Control.

Maximum Amp Rating	120V	240V
Running	5.8	2.9
Locked Rotor	34.8	17.4
Non-inductive	12	6

Figure 2 Adjustable Auxiliary Switch SPDT.



- ① As diagrammed, increasing input causes CW actuator rotation. All references to the direction of rotation are determined by facing the actuator output shaft.
- ② The wires to terminals 7 and 8, and 2 and 3, may be reversed for CCW rotation with an increasing input signal.
- ③ 24 Vac models are equipped with a green jumper from terminal G to the case ground screw.
- ④ The green/yellow wire must be installed under the terminal block mounting screw. In field, disconnect and remove green jumper.
- ⑤ Shield must be grounded to the terminal block mounting screw.
- ⑥ Purge override (input signal override) is available on CP-9302 only. A dry contact closure from the override input (violet/white) lead to the blue lead of the actuator drive forces the actuator to drive to the end of travel, independent of the input signal conditions. Connecting the violet/white and violet leads together forces the actuator to drive to the opposite (high input signal) end of travel, independent of input signal conditions.

Figure 3 Proportional Electric Control, CP-930X.

**Reversible and Proportional
Electric Actuators
MP-3XX Series**





Electronic Actuator Drive CP-9301-XXX Series, CP-9302 Series

Application

The CP-9301 and CP-9302 electronic actuator drives process a variable input signal from a controller to provide proportional control of an electric gear train actuator. The CP-9301 is preset at the factory for voltage input. The CP-9302 is factory preset for current input and has additional wiring for connection to an override switch, for those applications requiring an external override of the input signal. These drives are equipped with built-in jumpers and adjustable potentiometers, so that the type of input signal, deadband, input span, and start point may be reset in the field when necessary.



Features

- Mounts directly onto Invensys proportional, electric, gear train actuators.
- Power is supplied directly from the actuator.
- May be used with all gear train actuator voltages and frequencies.
- Jumpers for selecting either voltage or current input, as well as 3% or 5% deadband.
- Adjustable span and start point potentiometers.

Model Chart

Part Number	Input Signal Override	Factory Jumper Settings				Jumper Settings		Potentiometer Adjustment Ranges	
		Input Signal	Deadband	Start Point	Input Span	Input Signal	Deadband	Input Span	Start Point
CP-9301	Not Available	Voltage (6 to 9 Vdc)	3% of Input Span	6 Vdc	3 Vdc	Voltage or Current	3% or 5% of Input Span	3.0 to 16.5 Vdc or 8 to 16 mAdc	0 to 10 Vdc or 2 to 16 mAdc
CP-9301-456		0 to 10 Vdc		0 Vdc	10 Vdc				
CP-9302	Available (Use is Optional)	Current (4 to 20 mAdc)		4 mAdc	16 mAdc				

Typical Actuators.

Actuator Series	Power		Torque		Stroke Degrees	Spring Return
	Vac 60 Hz	Amp	Lb-in.	N-m		
MP-361	24	2.5	50	5.6	180	CW
MP-371	24	2.5	50	5.6	180	CCW
MP-381	24	2.5	220	24.9	180	—

Caution: When using the CP-9301 or CP-9302 with actuators containing an *internal transformer*, disconnect and tape off the red and blue leads before installing and powering the device. *Failure to do so can result in damage to the actuator drive.*

Note: Models prior to “-2” suffix had transformer wired directly to potentiometer. To disconnect the transformer, remove the back plate of the actuator, then disconnect and tape the transformer leads.

**Electronic Actuator Drive
CP-9301-XXX Series, CP-9302
Series**



Specifications

Mounting	Directly to an actuator. The drive may be mounted on either the left or right side of the actuator, in a conduit opening adjacent to the low voltage wiring compartment.
Case	Injection molded plastic with stamped aluminum cover.
Inputs - Voltage and Current	
Input	Refer to Model Chart.
Input Span Adjustment	Refer to Model Chart.
Start Point Adjustment	Refer to Model Chart.
Input Impedance	
Voltage Input	Greater than 10,000 ohms.
Current Input	250 ohms.
Power Supply	Power is supplied directly from the shading coil windings provided on the shaded pole reversible motor of the gear train actuator (less than 30 Vac).
Outputs	
Connections	Color-coded leads with crimped screw terminal connectors. Purge override (input signal override) leads are color-coded pigtailed.
Triac Output	1.2 A RMS.
Deadband	Refer to Model Chart.
Environment	
Ambient temperature limits	
Shipping & Storage	-40 to 160 °F (-40 to 71 °C).
Operating	-40 to 136 °F (-40 to 58 °C).
Humidity	5 to 95% RH, non-condensing.
Locations	NEMA Type 4; IEC IP56.
Agency Listings	
UL Listed	UL 873 (File #E9429 Category Temperature Indicating and Regulating Equipment). Certified for use in Canada by Underwriters Laboratories.
European Community	EMC Directive 89/336/EEC.

Typical Applications

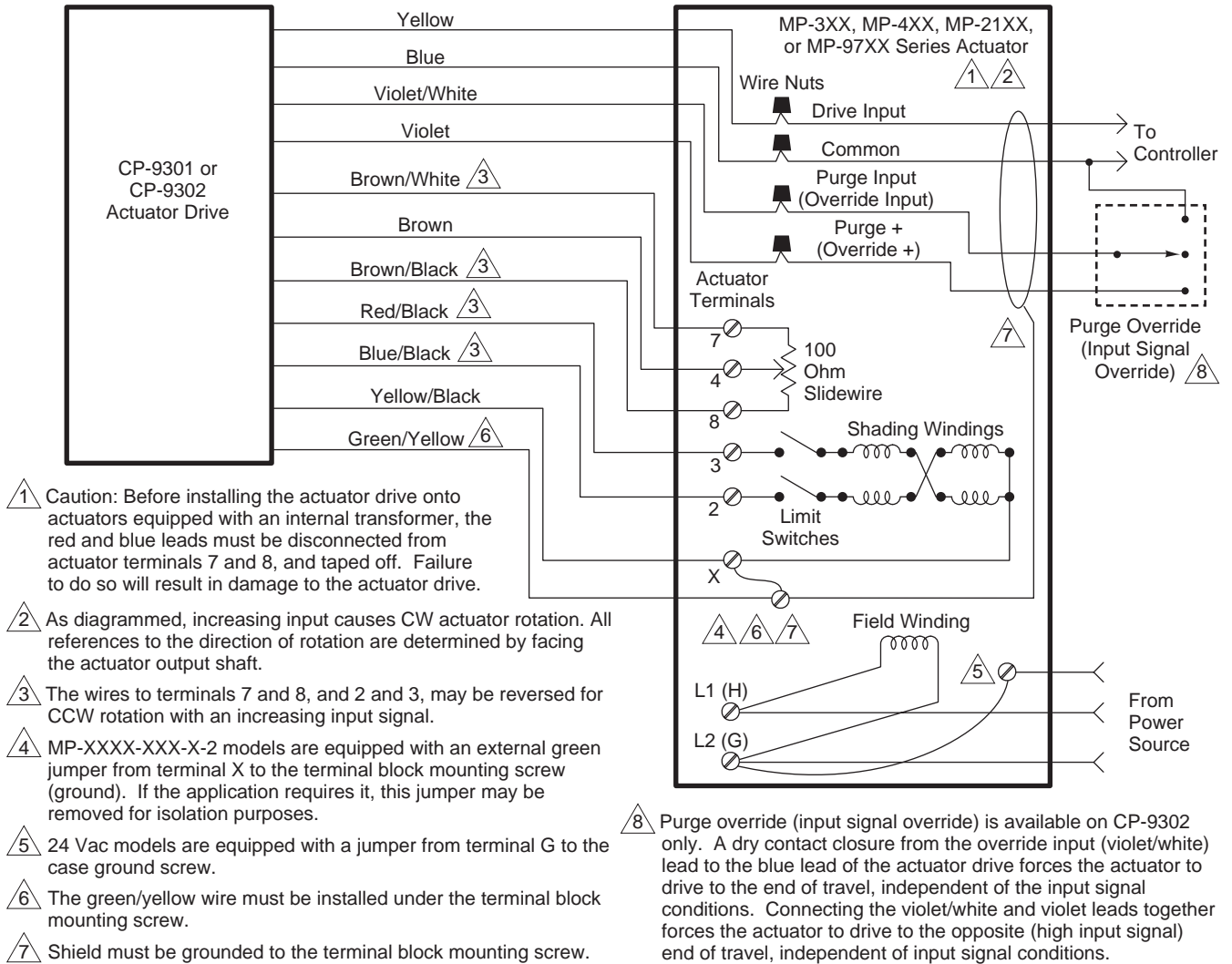

Figure 1 Service Application Wiring Diagram.

**Electronic Actuator Drive
CP-9301-XXX Series, CP-9302
Series**





2-Way Globe Valves with Electric Gear Train Actuators

Select Actuator Type with correct Input Signal having sufficient close-off for the application. A valve assembly will require a valve body, actuator and a valve linkage. If selecting Component Parts, select Valve Linkage.

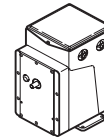
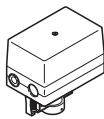

Valve Linkage	1-1/4 in. to 2 in.	Included		AV-391	AV-393	—
	2-1/2 to 4 in.	AV-672		AV-395	AV-396	AV-352
	5 to 6 in.	—		—	—	AV-352
Normal Position			None	N.O. or N.C.	None	None
Actuator Types			MF-63103	MF-63123	MP-361 (N.C.), 371 (N.O.)	MP-38X
Valve Body	P Code	Size in.	ACTUATOR CLOSE-OFF PRESSURE RATING (psi)^{a b}			
VB-7213-0-4-P	-9	1-1/4	150	90	200	
	-10	1-1/2	100	60	140	
	-11	2	50	35	80	
VB-9213-0-4-P	-12	2-1/2	35	22	50	110
	-13	3	25	14	35	70
VB-9213-0-5-P	-12	2-1/2	35	22	50	110
	-13	3	25	14	35	70
	-14	4	13	7	19	40
	-15	5	—	—	—	18
	-16	6	—	—	—	11

^a Seat leakage rating is ANSI IV (0.01% of Cv).

^b Close-off pressure ratings describe only the differential pressure which the actuator can close-off with adequate seating force. Consult valve body specifications for other limitations.

Consult Invensys Building Systems-Americas Catalog, F-25683 for further information.

**2-Way Globe Valves with Electric
Gear Train Actuators**





3-Way Globe Valves with Electric Gear Train Actuators

Select Actuator Type with correct Input Signal having sufficient close-off for the application. A valve assembly will require a valve body, actuator and a valve linkage. If selecting Component Parts, select Valve Linkage.

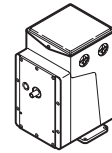
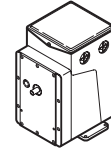
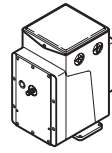

Valve Linkage VB-7313	1-1/4 to 2 in.		AV-391	AV-393	—			
Valve Linkage VB-9313	2-1/2 to 4 in.		AV-395	AV-396	AV-352			
	5 to 6 in.		—	—				
Valve Linkage VB-9323	2-1/2 to 3 in.		AV-300 and AV-29	AV-300 and AV-30	—			
	4 to 6 in.		—	—	AV-352			
Actuator Types			MP-36X ^a MP-37X ^a	MP-38X				
Valve Body	P Code	Size in.	ACTUATOR CLOSE-OFF PRESSURE RATING (psi)^{b c d e}					
			SU	SD	SU	SD	SU	SD
VB-7313-0-4-P	-9	1-1/4	90	90	200	200	—	—
	-10	1-1/2	60	60	140	140	—	—
	-11	2	35	35	80	80	—	—
VB-9313-0-4-P	-12	2-1/2	20	20	50	50	110	110
	-13	3	12	12	35	35	70	70
VB-9313-0-5-P	-12	2-1/2	20	20	50	50	110	110
	-13	3	12	12	35	35	70	70
	-14	4	6	6	17	17	40	40
	-15	5	—	—	—	—	18	18
	-16	6	—	—	—	—	11	11
VB-9323-05-P	-12	2-1/2	—	—	125	125	—	—
	-13	3	—	—	125	125	—	—
	-14	4	—	—	—	—	125	125
	-15	5	—	—	—	—	125	125
	-16	6	—	—	—	—	125	125

^a Use MP-361 for normally stem down, MP-371 for normally stem up.

^b Close-off ratings for mixing: (SU = "A" port, SD = "B" port). "A" port (SU) ratings equal pressure at port "A" minus pressure at port "B". "B" port (SD) ratings equal pressure at port "B" minus pressure at port "A".

^c SU = Stem Up; SD = Stem Down.

^d Close-off pressure ratings describe only the differential pressure which the actuator can close-off to standards with adequate seating force. Consult valve body specifications for the limitations.

^e Leakage ratings on 2 1/2 to 6 inch VB-9323 diverting valves are ANSI II (0.5% of Cv). Maximum differential pressure between opposite end ports is 50 psi. Leakage ratings on 2-1/2 to 6 inch VB-7313 and VB-9313 are ANSI III (0.1% of Cv).

3-Way Globe Valves with Electric Gear Train Actuators



Select Actuator Type with correct Input Signal having sufficient close-off for the application. A valve assembly will require a valve body, actuator and a valve linkage. If selecting Component Parts, select Valve Linkage.

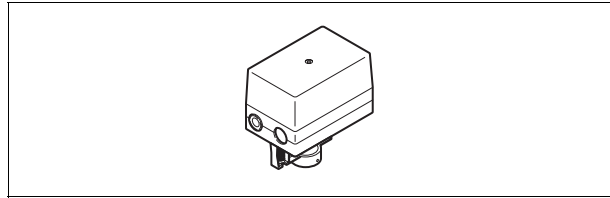

Input Signal			Floating SPDT and Multiple Input	
Valve Linkage for VB-7313	1-1/4 to 2 in.		Included	
Valve Linkage for VB-9313	2-1/2 to 4 in.		AV-672	
Actuator Types			MF-63103	MF-63123
Valve Body	P Code	Size in.	ACTUATOR CLOSE-OFF PRESSURE RATING (psi)^{a b c d}	
			SD	SU
VB-7313-0-4-P VB-7314-0-4-P	-9	1-1/4	140	140
	-10	1-1/2	90	90
	-11	2	50	50
VB-9313-0-4-P VB-9313-0-5-P	-12	2-1/2	35	35
	-13	3	25	25
	-14	4	13	13
	-15	5	—	—
	-16	6	—	—

- ^a Close-off ratings for mixing or diverting valves: (SU = "A" port, SD = "B" port). "A" port (SU) ratings equal pressure at port "A" minus pressure at port "B". "B" port (SD) ratings equal pressure at port "B" minus pressure at port "A".
- ^b SU = Stem Up; SD = Stem Down.
- ^c Close-off pressure ratings describe only the differential pressure which the actuator can close-off to standards with adequate seating force. Consult valve body specifications for other limitations.
- ^d Do not use mixing valves on diverting applications. Diverting valves may be used in mixing applications with minor affect on flow.

Consult Invensys Building Systems-Americas Catalog, F-25683 for further information.

Application

VB-7213 series single seat, stem up open, two-way valves control water from 20 to 281°F (-7 to 138 °C) or steam to 281°F (138 °C) maximum in heating or air conditioning systems. They are used for two-position or proportional control applications. Valve assemblies require an actuator and a valve linkage. A large selection of factory assembled combinations is available. Consult the *Invensys Building Systems-Americas Environmental Controls Catalog*, F-25683.



Danger: Do not use for combustible gas applications. The VB-7213 series valve packings are not rated for combustible gas applications, and if used in these applications, gas leaks and explosions could result.



VB-7213

Features

- Valve sizes 1-1/4" to 2"
- 250 psig pressure rating per ANSI Standards (B16.15–1985) for screwed cast bronze bodies
- Spring-loaded TFE packing
- American Standard Taper Pipe Thread (NPT) connections

Specifications

			Valve Body Series VB-7213-0-4-P
Service			Chilled or Hot Water and Steam
Flow Characteristics			Equal Percentage
Action			Stem Up Closed
Sizes			1-1/4" to 2"
Type of End Fitting			NPT
Valve Materials	Body		Bronze
	Seat		Bronze
	Stem		Stainless Steel
	Plug		Brass
	Packing		Spring-loaded TFE
	Disc		EPDM
ANSI Pressure Class			250 (up to 400 psig below 150 °F) ^a
Maximum Inlet Pressure, Steam			35 psig (241 kPa)
Allowable Control Media Temperature			20 to 281 °F (-7 to 138 °C)
Allowable Differential Pressure for Water^b			35 psi (241 kPa) Maximum for Normal Life
Allowable Differential Pressure for Steam^b			20 psi (138 kPa)
Valve Size^c	Cv Rating	kvs Rating^d	Complete Valve Body Part Number
1-1/4"	20	17	VB-7213-0-4-9
1-1/2"	28	24	VB-7213-0-4-10
2"	40	35	VB-7213-0-4-11

^a Pressure rating of valve only. Do not apply to system piping.

^b Maximum recommended differential pressure. Do not exceed recommended differential pressure (pressure drop) or integrity of parts may be affected. Exceeding maximum recommended differential pressure voids product warranty.

^c Smaller valve sizes are available.

^d $kvs = m^3/h$ ($\Delta P = 100$ kPa) $Cv = kvs \times 1.156$

Consult *Invensys Building Systems-Americas Catalog*, F-25683 for further information.

**Two-Way Valve
VB-7213**



Application

VB-7313 series three-way mixing valves control hot or chilled water in heating or air conditioning systems. These valves must be piped with two inlets (“A” and “B” ports) and one outlet (“AB” port). They are used for two-position or proportional control applications. Valve assemblies require an actuator and a valve linkage that must be purchased separately.



Danger: Do not use for combustible gas applications. The VB-7313 series valve packings are not rated for combustible gas applications, and if used in these applications, gas leaks and explosions could result.



VB-7313

Features

- Valve sizes 1-1/4" to 2"
- 250 psig pressure rating per ANSI Standards (B16.15-1985) for screwed cast bronze bodies
- Spring-loaded TFE packing
- American Standard Taper Pipe Thread (NPT) connections

Specifications

			Valve Body Series VB-7313-0-4-P
Service			Chilled or Hot Water
Flow Characteristics			Mixing
Sizes			1-1/4" to 2"
Type of End Fitting			NPT
Valve Materials	Body		Bronze
	Seat		Bronze
	Stem		Stainless Steel
	Plug		Brass
	Packing		Spring-loaded TFE
	Disc		None
ANSI Pressure Class			250 (up to 400 psig below 150 °F) ^a
Allowable Control Media Temperature			20 to 281 °F (-7 to 138 °C)
Allowable Differential Pressure for Water^b			35 psi (241 kPa) Maximum for Normal Life
Valve Size^c	Cv Rating	kvs Rating^d	Complete Valve Body Part Number
1-1/4"	20	17	VB-7313-0-4-9
1-1/2"	28	24	VB-7313-0-4-10
2"	41	35	VB-7313-0-4-11

^a Pressure rating of valve only. Do not apply to system piping.

^b Maximum recommended differential pressure. Do not exceed recommended differential pressure (pressure drop) or integrity of parts may be affected. Exceeding maximum recommended differential pressure voids product warranty.

^c Smaller valve sizes are available.

^d $kvs = m^3/h$ (DP = 100 kPa) $Cv = kvs \times 1.156$

**Three-Way Mixing Valve
VB-7313**



Application

VB-9213 series single seat, stem down to close, two-way valves control water from 40 to 281 °F (4 to 138 °C) or steam to 281 °F (138 °C) maximum in heating or air conditioning systems. They are used for two-position or proportional control applications. Valve assemblies require an actuator and a valve linkage that must be purchased separately.



Danger: Do not use for combustible gas applications. The VB-9213 series valve packings are not rated for combustible gas applications, and if used in these applications, gas leaks and explosions will result.



Typical of VB-9213-0-5-P
2-1/2" to 6"

Features

- Valve sizes 2-1/2" to 6".
- 250 psig pressure rating per ANSI Standards (B16.15–1985) for screwed cast bronze bodies.
- 125 psig pressure rating per ANSI Standards (B16.1–1993) for flanged cast iron bodies.
- Spring-loaded TFE packing.

Specifications

			Valve Body Series	
			VB-9213-0-4-P	VB-9213-0-5-P
Service			Chilled or Hot Water and Steam	
Flow Characteristics			Equal Percentage	
Sizes			2-1/2" to 3"	2-1/2" to 6"
Type of End Fitting			Screwed NPT	125 lb. Flanged
Valve Materials	Body		Bronze	Iron
	Seat		Bronze	
	Stem		Stainless Steel	
	Plug		Brass	
	Packing		Spring-loaded TFE	
	Disc		Composition	
ANSI Pressure Class			250 (up to 400 psig below 150 °F)	125 lb. Flanged (up to 200 psig below 150 °F)
Maximum Inlet Pressure, Steam			35 psig (241 kPa)	
Allowable Control Media Temperature			40 to 281 °F (4 to 138 °C)	
Allowable Differential Pressure for Water^a			35 psi (241 kPa) Maximum for Normal Life	
Allowable Differential Pressure for Steam^a			20 psi (138 kPa)	
Valve Size	Cv Rating	kvs Rating^b	Complete Valve Body Part Number	
2-1/2"	56	48	Not Available	VB-9213-0-5-12
	65	56	VB-9213-0-4-12	Not Available
3"	85	73	VB-9213-0-4-13	VB-9213-0-5-13
4"	145	125	Not Available	VB-9213-0-5-14
5"	235	203		VB-9213-0-5-15
6"	350	302		VB-9213-0-5-16

^a Maximum recommended differential pressure in open position. Do not exceed recommended differential pressure (pressure drop) or integrity of parts may be affected. Exceeding maximum recommended differential pressure voids product warranty.

^b kvs = m³/h (ΔP = 100 kPa) Cv = kvs x 1.156

**Two-Way Valve
VB-9213**



Application

VB-9313 series three-way mixing valves control hot or chilled water in heating or air conditioning systems. These valves must be piped with two inlets ("A" and "B" ports) and one outlet ("AB" port). They are used for two-position or proportional control applications. Valve assemblies require an actuator and a valve linkage that must be purchased separately.



Danger: Do not use for combustible gas applications. The VB-9313 series valve packings are not rated for combustible gas applications, and if used in these applications, gas leaks and explosions will result.



Typical of VB-9313-0-5-P
2-1/2" to 6"

Features

- Valve sizes 2-1/2" to 6".
- 250 psig pressure rating per ANSI Standards (B16.15-1985) for screwed cast bronze bodies.
- 125 psig pressure rating per ANSI Standards (B16.1-1993) for flanged cast iron bodies.
- Spring-loaded TFE packing.

Specifications

Specifications			Valve Body Series VB-9313-0-4-P	Valve Body Series VB-9313-0-5-P
Service			Chilled or Hot Water	
Flow Characteristics			Mixing	
Sizes			2-1/2" and 3"	2-1/2" to 6"
Type of End Fitting			Screwed NPT	125 lb. Flanged
Valve Materials	Body		Bronze	Iron
	Seat		Bronze	
	Stem		Stainless Steel	
	Plug		Brass	
	Packing		Spring-loaded TFE	
	Disc		None	
ANSI Pressure Class			250 (up to 400 psig below 150 °F)	125 lb. Flanged (up to 200 psig below 150 °F)
Allowable Control Media Temperature			40 to 300 °F (4 to 149 °C)	
Allowable Differential Pressure for Water^a			35 psi (241 kPa) Maximum for Normal Life	
Valve Size	Cv Rating	kvs Rating^b	Complete Valve Body Part Number	
2-1/2"	67	58	VB-9313-0-4-12	Not Available
	74	64	Not Available	VB-9313-0-5-12
3"	91	79	VB-9313-0-4-13	Not Available
	101	87	Not Available	VB-9313-0-5-13
4"	170	147		VB-9313-0-5-14
5"	290	251		VB-9313-0-5-15
6"	390	337		VB-9313-0-5-16

^a Maximum recommended differential pressure in open position. Do not exceed recommended differential pressure (pressure drop) or integrity of parts may be affected. Exceeding maximum recommended differential pressure voids product warranty.

^b kvs = m³/h (ΔP = 100 kPa) Cv = kvs x 1.156

**Three-Way Mixing Valve
VB-9313**



Application

AV-352 valve linkage is used to field-install gear train actuators on specified 2-1/2 to 6 in. valve bodies.

Features

- Compatible with Invensys (Barber-Colman) 2-1/2 to 6 in. valves.
- Provides increased close-off pressure on 2-1/2 to 4 in. valves.
- Required for rated close-off pressure on 5 and 6 in. valves.

Specifications

- Actuator mounting: In any upright position with actuator above the center line of the valve body.
- Minimum actuator torque required: 220 lb-in.
- Actuator travel required: 180°.



AV-352

**Valve Linkage for Gear Train
Actuators
AV-352**



Application

The AV-390 through AV-396 linkages are used to field assemble gear train actuators to VB-7XXX series or VB-9XXX series valve bodies.

- AV-391 and AV-393 are used with current 1/2" to 2" VB-7X1X and obsolete 1/2" to 1-1/4" VB-9X1X valve bodies.
- AV-395 and AV-396 are used with current 2-1/2" to 4" VB-9X1X valve bodies.

Features

- Die cast aluminum mounting bracket.
- Valve position indication provided as standard.

Specifications

Actuator Torque: 50 in-lb minimum for AV-391 and AV-395. 130 in-lb minimum for AV-393 and AV-396.

Temperature Restrictions: Verify that the fluid temperature of the media in the valve versus the ambient temperature at the actuator does not exceed the ratings shown in Table-1

TABLE 1. Restrictions on Maximum Ambient Temperature for Actuators.

Maximum Temperature of Media in the Valve (Check Rating of Valve) °F (°C)	Maximum Ambient for Actuator °F (°C)
260 (126)	136 (57)
281 (138)	125 (52)
300 to 366 (149 to 185)	100 (37)

Close-off Pressure Ratings: Refer to page 37 and page 39. Check the appropriate table to verify that the selected valve, valve linkage, and actuator provide adequate close-off pressure for your application.



AV-390

**Valve Linkage for Gear Train
Actuators
AV-390**



Application

The VAT/VAP series valve actuators are designed for proportional voltage or current, or 3-wire floating of VBG series 2-way and 3-way globe valve.

The VAT/VAP series actuators feature a reversible synchronous motor with an integral magnetic clutch to eliminate the need for position switches and enhance the overall reliability of the actuator. Position feedback from a 0 to 1000 ohm potentiometer for the VAT, or from a 0 to 10 VCD potentiometer for the VAP, is a standard feature on all units. An auxiliary switch is available as an accessory on both models, field option kit D36PS1 (ordered separately).

For ease of installation, the VAT/VAP series actuators mount directly onto the VBG series valves in minutes, without the need for linkages or field calibration of the travel or span of the actuators.

For best control results, the VAT actuator can be controlled by virtually any 3-wire floating control signal. The thermostat or controller should be selected or adjusted to complement the stroke time of the VAT actuator.

The VAP actuator can be controlled by any proportional voltage or current output. The circuit board allows the user to select one of seven different operating ranges, as well as the direction of stroke. The thermostat or controller should be selected or adjusted to complement the stroke time of the VAP actuator.

The VAT/VAP valve actuator is furnished with a “time out” feature to extend the life of the drive motor. When an open or close signal has been sustained for more than 130 seconds, the circuit board turns off the motor until the control signal changes.

The VAP actuator is shipped as a direct acting actuator, which means that the valve opens upon an increase in control signal. To change the reverse action, reposition the jumper SW2 to the “A” position (Figure-4). The control operating range can also be changed by repositioning jumper SW1 to the desired operating range.



VAT Actuator on VBG Body

Actuator Specifications

Control Signal: VAT100ANS—3-Wire floating.

VAP100ANS—0 to 10 Vdc; field selectable for 1 to 5, 2 to 10, 4 to 7, 6 to 9, 8 to 11 Vdc, or 4 to 20 mA.

Feedback Signal: VAT100ANS—0 to 1000 Ω (direct or reverse acting). VAP100ANS—1 to 10 Vdc (direct or reverse acting) or 0 to 20 mA (direct or reverse acting).

Maximum Close-Off Pressure on Erie VBG Series

Valves: 1-1/4 in. valve—58 psi (4 bar), 1-1/2 in. valve—36 psi (2.5 bar), 2 in. valve—30 psi (2 bar).

Power Signal: Nominal 24 Vac 3-wire, -15%, +10%, 50/60 Hz.

Input Impedance: 100K ohms.

Power Consumption: 5 VA.

Stroke Time: 65 seconds at 60 Hz.

Maximum Stroke: 7/8 in (21 mm).

Close-Off Force: 100 ft-lb (450 N).

Maximum Fluid Temperature: 250 °F (120 °C).

Ambient Operating Limits: 23 to 122 °F (-5 to 50 °C) at 80% RH maximum.

Ambient Storage Temperature Limits: -13 to 149 °F (-25 to 65 °C).

Materials: Thermoplastic and technopolimer enclosure.

Wiring Connections: Terminal strip.

Approvals: CE marked compliant.

Shipping Weight: 1.7 lb. (0.8 kg)

Accessories

An auxiliary switch (p/n D36PS1) can be ordered separately to be installed in the actuator. The switch is single pole double throw (SPDT) and can be adjusted to actuate at any valve position. The switch is rated for 10 amps resistive, 3 amps inductive, at 250 Vac.

Globe Valve Actuator VAT/VAP100 Series

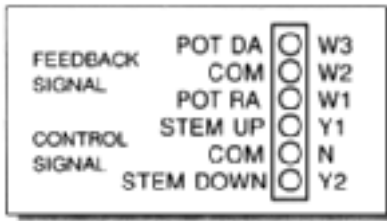

Figure 1 VAT100ANS Wiring.

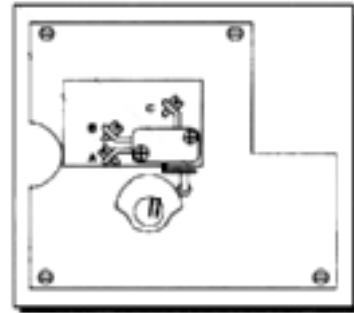

Figure 3 D26PSI Auxiliary Switch.

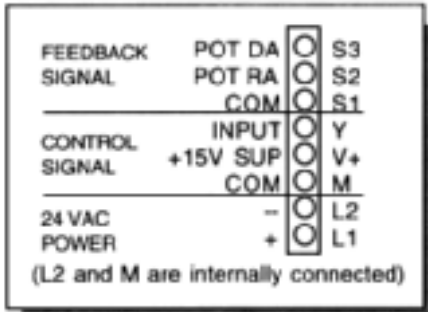

Figure 2 VAP100ANS Wiring.

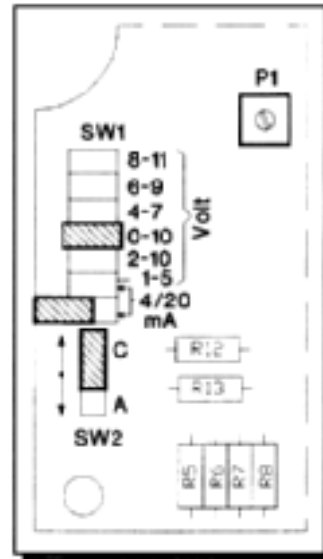

Figure 4 VAP100ANS Circuit Board Detail.

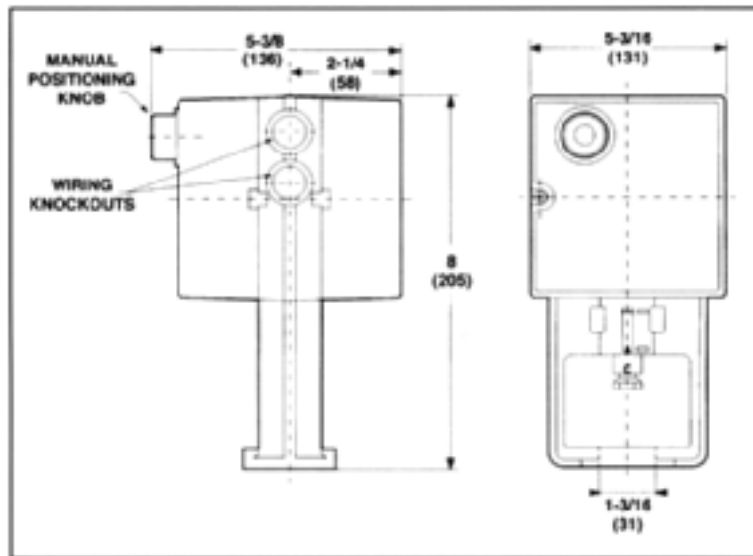

Figure 5 Dimensions, shown in inches (mm).

Application

The VAT/VAP series valve actuators are designed for proportional voltage or current or 3-wire floating control of VBF series 2-way and 3-way globe valves. All units are equipped with usual position indications and a manual override.

The VAT/VAP series actuators feature a reversible synchronous motor. Position feedback signal of 0 to 10 Vdc or 0 to 200 mA is available on model VAP270ANS as a standard feature. An auxiliary switch is also available as an accessory, field option kit D270S1 (ordered separately).

For ease of installation, the VAT/VAP270 series actuators mount directly onto the VBF series valves in minutes, without the need for linkages or field calibration of the travel or span of the actuator.

For best control results, the VAT/VAP Series actuators can be controlled by virtually any proportional voltage or current or 3-wire floating input. The circuit board of the VAP270ANS actuator allows the user to select one of the seven different operating ranges, as well as the direction of stroke. The thermostat or controller should be selected or adjusted to complement the stroke time of the VAT/VAP270 series actuator.

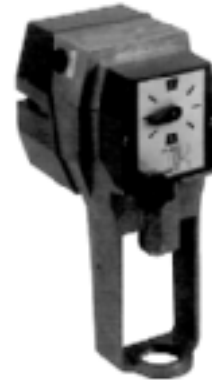

VAT/VAT-270 Series Actuator

Actuator Specifications

Control Signal: VAT270ANS—3-Wire floating.

VAP270ANS—Factory set for 0 to 10 Vdc; field selectable for 1 to 5, 2 to 10, 4 to 7, 6 to 9, 8 to 11 Vdc, or 4 to 20 mA.

Feedback Signal (Direct or Reverse Acting):

VAT270ANS—None, **VAP270ANS**—0 to 10 Vdc or 0 to 200 μ A.

Power Supply: Nominal 24 Vac -15%, +10%, 50/60 Hz.

Input Impedance: 100K ohms.

Power Consumption: 9 VA.

Stroke Time at 60 Hz (50 Hz): 67 (80) seconds.

Maximum Stroke: 1-3/4" (45 mm).

Close-Off Force: 270 ft-lb (1200 N).

Motor Transmission: Crank-arm.

Maximum Fluid Temperature: 250 °F (120 °C)

Ambient Operating Limits: 32 to 122 oF (-0 to 50 °C)

Ambient Storage Temperature Limits: -13 to 149 °F (-25 to 65 °C).

Enclosure: Die-cast aluminum housing and plastic cover.

Wiring Connections: Terminal strip.

Approvals: CE marked compliant.

Shipping Weight: 4.4 lb. (2 kg).

Model Chart

VAT270ANS	3-wire floating, 270 ft-lb, non-spring return.
VAP270ANS	Proportional 0-10 Vdc or 4 to 20 mA, 270 ft-lb, non-spring return.

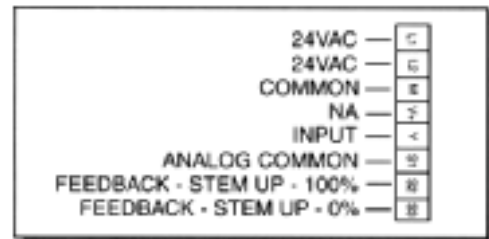

Figure 1 VAP270 Wiring Diagram.

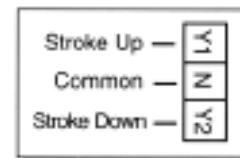

Figure 2 VAT270 Non-Spring Return.

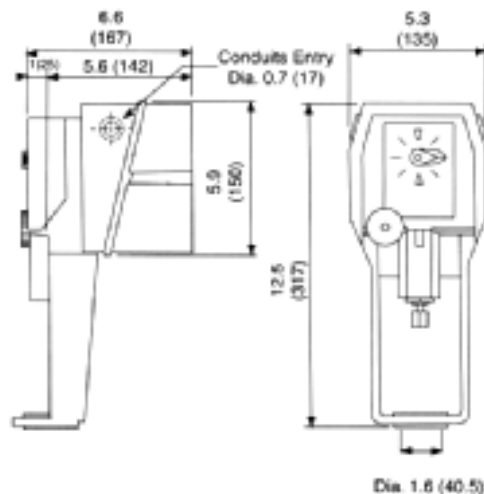

Figure 3 Dimensions, shown in inches (mm).

**Globe Valve Actuator
VAT/VAP270 Series**



Application

The VAT/VAP series valve actuators are designed for proportional voltage or current or 3-wire floating control of VBF series 2-way and 3-way globe valves. All units are equipped with usual position indication and a manual override device.

The VAT/VAP series actuators feature a reversible synchronous motor with a torque limited device to eliminate the need for position switches and enhance the overall reliability of the actuator. Position feedback signal of 0 to 10 Vdc or 0 to 200 μ A is available on VAP340AN_ models as a standard feature. An auxiliary switch is also available as an accessory, field option kit D340S1 (ordered separately).

For ease of installation, the VAT/VAP340 series actuators mount directly onto the VBF series valves in minutes, without the need for linkages or field calibration of the travel or span of the actuator.

For best control results, the VAT/VAP340 series actuators can be controlled by virtually any proportional voltage or current or 3-wire floating input. The circuit board of the VAP340 actuator allows the user to select one of the seven different operating ranges, as well as the direction of stroke. The thermostat or controller should be selected or adjusted to complement the stroke time of the VAT/VAP340 series actuator.

Actuator Specifications

Control Signal:

VAT340ANS, VAT340ANC, VAT340ANO—3-Wire floating.
VAP340ANS, VAP340ANC, VAP340ANO—Factory set for 0 to 10 Vdc; field selectable for 1 to 5, 2 to 10, 4 to 7, 6 to 9, 8 to 11 Vdc, or 4 to 20 mA.

Power Supply: Nominal 24 Vac, -15%, +10%, 50/60 Hz.

Input Impedance: 100K Ω .

Power Consumption: 12 VA.

Feedback Signal (Direct or Reverse Acting): 0 to 10 Vcd or 0 to 200 μ A.

Stroke Time at 60 Hz (50 Hz): 28 (34) seconds/inch.

Spring Return Time at 60 Hz (50 Hz): 20 (25) seconds/inch.

Maximum Stroke: 1-3/4" (45 mm).

Close-Off Force: 333 ft-lb (1500 N), 155 ft-lb (700 N) for spring return models.

Motor Transmission: Rack and pinion.

Ambient Operating Limits: 5 to 122 °F (-15 to 50 °C).

Ambient Storage Temperature Limits: -13 to 149 °F (-25 to 65 °C).

Enclosure: Die-cast aluminum housing and plastic cover.

Wiring Connections: Terminal strip.

Approvals: CE marked compliant.

Shipping Weight: 6.6 lb. (3 kg), or 8.8 lb. (4 kg) for spring return model.



VAT/VAP340 Series Actuator

Model Chart

Table-1 Model Chart.	
VAT340ANS	3-wire floating, 340 ft-lb, non-spring return
VAT340ANC	3-wire floating, 340 ft-lb, spring-close
VAT340ANO	3-wire floating, 340 ft-lb, spring-open
VAP340ANS	Proportional 0-10Vdc or 4-20mA, 340 ft-lb, non-spring return
VAP340ANC	Proportional 0-10 Vdc or 4-20mA, 270 ft-lb, spring-close
VAP340ANO	Proportional 0-10Vdc or 4-20mA, 270 ft-lb, spring-open

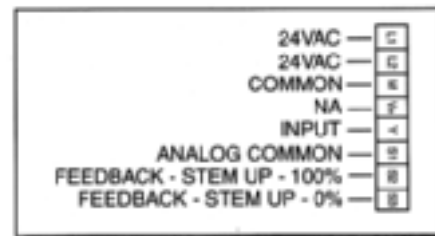

Figure 1 VAP340AN_ Wiring.

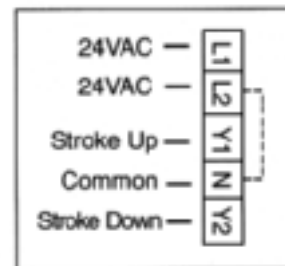

Figure 2 VAT340 Spring Return.

Globe Valve Actuator
VAT/VAP340 Series

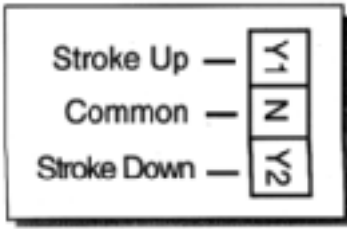

Figure 3 VAT340 Non-Spring Return.

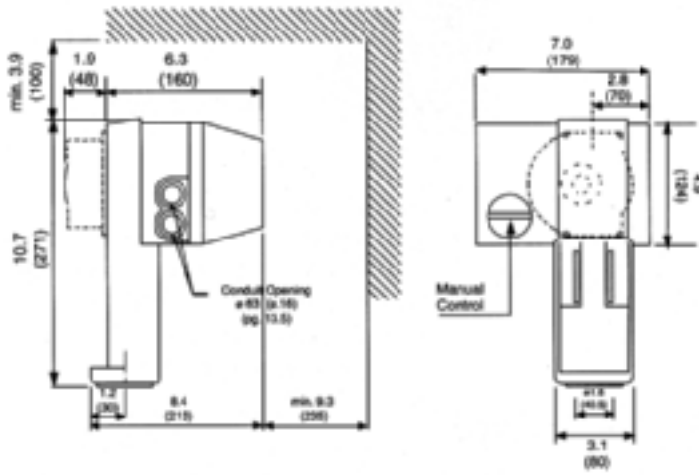

Figure 4 Dimensions, shown in inches (mm).

Application

The VBF series globe valves are engineered specifically for temperature control applications requiring an equal percentage flow characteristic and a high degree of control precision. Common applications include hot water, chilled water, and low pressure steam coils and heat exchangers in air handling units, chillers, boilers, and cooling towers.

The VBF series valves are designed with ANSI flanged connections, in 2-way and 3-way configurations.

All VBF series valves are operated by VAT/VAP series electric actuators which are ordered separately. The actuators are designed specifically for mounting directly to the VBF series valves without the need of linkages or time-consuming field calibration.

Pipe Connections

Install according to flow direction as indicated on valve body.

Valve Mounting

Before mounting valve, be sure that pipes are clean and free from welding slag. It is essential that pipes be lined up squarely with the valve at each connection, free from vibrations. For installations on plants with higher temperature fluid (steam, superheated steam, water, or diathermic fluid), use expansion joints to avoid pipe bucking against valve body. With high fluid temperatures do not mount the actuator in a vertical position on the valve to avoid direct exposure to heat sources, see Figure-1.



Figure 1 Installation Positions.

Leave sufficient clearance for actuator removal.

Valve must not be installed in explosive atmosphere, nor at ambient temperature higher than 122 °F (50 °C) or lower than 23 °F (-5 °C); must not be subject to steam jets, water jets or dripping.

Note: Actuator may be rotated 180° with respect to valve body by loosening lock nut of valve body. After this operation, tighten lock nut.



VBF Flanged Globe Valve

Valve Specifications

Body Rating: 250 PSI (1600 kPa, 16 bar).

Maximum Recommended Differential: 35 PSIG (24 kPa).

Flow Characteristic: **2-Way**—Equal percentage, **3-Way**—Service port A—equal percentage, bypass port B—linear.

Service: Hot and chilled water, up to 50% glycol, and low pressure steam.

Seat Leakage: **2-Way**—0.03% of Cv, **3-Way**—Service port A—0.03% of Cv, bypass port B—2% of Cv.

Fluid Temperature & Pressure Limits: 15 to 250 °F water (-10 to 120 °C), maximum 250 °F (120 °C) at 22 PSIA (150 kPa) steam.

Materials: **Body and Seat**—Cast iron, **Stem**—Stainless steel, **Plug**—Forged brass, **Stem Packing**—Buna N O-ring

Body Connections: ANSI flanges, 250 PSI (PN16)

Dimensions & Shipping Weights: See Figure-4, Figure-5, Table 1, and Table 2.

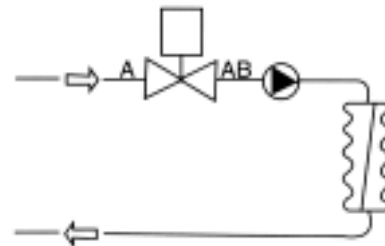

Figure 2 Two-Way Flow Direction.

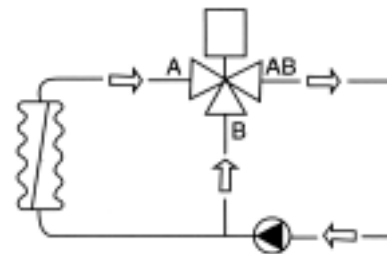

Figure 3 Three-Way Flow Direction.

Flanged Globe Valve Bodies

VBF Series

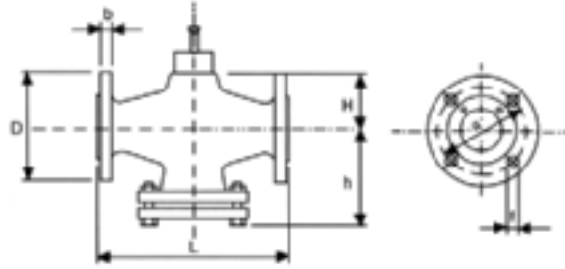

Figure 4 Two-Way Valve Body Dimensions, shown in inches (mm).

TABLE 1. Two-Way Valve Body Model Chart.

2-Way Model	Nominal Pipe Size in. (mm)	Body			Flanges		Bolt Holes		Bolting			Body Weight lb. (kg)
		L in. (mm)	H in. (mm)	h in. (mm)	D Diameter in. (mm)	b Thickness in. (mm)	a BHC in. (mm)	f Diameter in. (mm)	Number of Bolts	Diameter in. (mm)	Length in. (mm)	
VBF250AA2	2-1/2 (65)	11-1/2 (292)	2-13/16 (71)	6-7/8 (175)	7 (178)	11/16 (17)	5-1/2 (140)	3/4 (19)	4	5/8 (16)	2-1/2 (64)	50.7 (23)
VBF300AA2	3 (80)	12 (305)	3-3/16 (81)	7-5/16 (185)	7-1/2 (191)	13/16 (21)	6 (152)	3/4 (19)	4	5/8 (16)	2-1/2 (64)	61.7 (28)
VBF400AA2	4 (100)	13-1/2 (343)	3-11/16 (93)	8-1/16 (205)	9 (229)	13/16 (21)	7-1/2 (191)	3/4 (19)	8	5/8 (16)	3 (76)	77.2 (35)
VBF500AA2	5 (125)	15-1/2 (394)	4-1/2 (115)	9-1/16 (230)	10 (254)	7/8 (22)	8-1/2 (216)	7/8 (22)	8	3/4 (19)	3 (76)	108.0 (49)
VBF600AA2	6 (150)	18-3/4 (476)	5-1/4 (133)	10-5/8 (270)	11 (279)	15/16 (24)	9-1/2 (241)	7/8 (22)	8	3/4 (19)	3-1/4 (83)	143.3 (65)

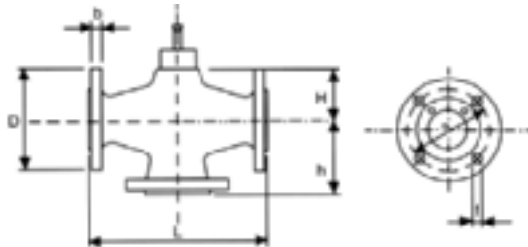

Figure 5 Three-Way Valve Body Dimensions, shown in inches (mm)

TABLE 2. Three-Way Valve Body Model Chart.

3-Way Model	Nominal Pipe Size in (mm)	Body			Flanges		Bolt Holes		Bolting			Body Weight lb. (kg)
		L in. (mm)	H in. (mm)	h in. (mm)	D Diameter in. (mm)	b Thickness in. (mm)	a BHC in. (mm)	f Diameter in. (mm)	Number of Bolts	Diameter in. (mm)	Length in. (mm)	
VBF250AA3	2-1/2 (65)	11-1/2 (292)	2-13/16 (71)	5-11/16 (145)	7 (178)	11/16 (17)	5-1/2 (140)	3/4 (19)	4	5/8 (16)	2-1/2 (64)	44.1 (20)
VBF300AA3	3 (80)	12 (305)	3-3/16 (81)	6-1/8 (155)	7-1/2 (191)	13/16 (21)	6 (152)	3/4 (19)	4	5/8 (16)	2-1/2 (64)	55.1 (25)
VBF400AA3	4 (100)	13-1/2 (343)	3-11/16 (93)	6-7/8 (175)	9 (229)	13/16 (21)	7-1/2 (191)	3/4 (19)	8	5/8 (16)	3 (76)	79.4 (36)
VBF500AA3	5 (125)	15-1/2 (394)	4-1/2 (115)	7-7/8 (200)	10 (254)	7/8 (22)	8-1/2 (216)	7/8 (22)	8	3/4 (19)	3 (76)	99.2 (45)
VBF600AA3	6 (150)	18-3/4 (476)	5-1/4 (133)	9-7/16 (240)	11 (279)	15/16 (24)	9-1/2 (241)	7/8 (22)	8	3/4 (19)	3-1/4 (83)	132.3 (60)

TABLE 3. Valve and Actuator Selection Guide.

2-Way VBF Bodies					Maximum ΔP PSI (kPa) Operating Actuator			Maximum ΔP PSI (kPa) Close-Off Actuator		
2-Way Model #	Valve Size in. (mm)	Stem Lift in. (mm)	Cv	Kv	VA_270ANS	VA_340ANS	VA_340ANC/NO	VA_270ANS	VA_340ANS	VA_340ANC/NO
VBF250AA2	2-1/2 (65mm)	1 (25mm)	74	63	30 (200)	30 (200)	20 (140)	41 (280)	53 (360)	20 (140)
VBF300AA2	3 (80mm)	1-3/4 (45mm)	117	100	25 (170)	30 (200)	11 (80)	25 (170)	34 (230)	11 (80)
VBF400AA2	4 (100mm)	1-3/4 (45mm)	187	160	12 (80)	20 (140)	6 (40)	12 (80)	20 (140)	6 (40)
VBF500AA2	5 (125mm)	1-3/4 (45mm)	292	250	7 (50)	12 (80)	4 (25)	7 (50)	12 (80)	4 (25)
VBF600AA2	6 (150mm)	1-3/4 (45mm)	421	360	5 (30)	6 (40)	2 (15)	5 (30)	6 (40)	2 (15)

3-Way VBF Bodies					Maximum ΔP PSI (kPa) Operating Actuator			Maximum ΔP PSI (kPa) Close-Off Actuator		
3-Way Model #	Valve Size in. (mm)	Stem Lift in. (mm)	Cv	Kv	VA_270ANS	VA_340ANS	VA_340ANC/NO	VA_270ANS	VA_340ANS	VA_340ANC/NO
VBF250AA3	2-1/2 (65mm)	1 (25mm)	74	63	30 (200)	30 (200)	22 (200)	44 (300)	58 (400)	22 (150)
VBF300AA3	3 (80mm)	1-3/4 (45mm)	117	100	26 (180)	30 (200)	13 (170)	26 (180)	35 (240)	13 (90)
VBF400AA3	4 (100mm)	1-3/4 (45mm)	187	160	15 (100)	22 (150)	7 (80)	15 (100)	22 (150)	7 (50)
VBF500AA3	5 (125mm)	1-3/4 (45mm)	292	250	9 (60)	13 (90)	4 (50)	9 (60)	13 (90)	4 (25)
VBF600AA3	6 (150mm)	1-3/4 (45mm)	421	360	6 (40)	7 (50)	2 (30)	6 (40)	7 (50)	2 (15)

TABLE 4. Port Configuration.

Port Configuration	
2-Way	Fully closed with stem up and fully open with stem down (stem up closed)
3-Way	Service Port A: Fully closed to port AB with stem up and fully open with stem down (stem up closed) Bypass Port B: Fully open to port AB with stem up and fully closed with stem down (stem up open)

TABLE 5. Valve Water Sizing Table, Water Capacity, gallons per minute (GPM).

Flow Coefficient, Cv	Differential Pressure, ΔP (PSI)									
	2	3	4	5	10	15	20	25	30	35
74	105	128	148	165	234	287	331	370	405	438
117	165	203	234	262	370	453	523	585	641	692
187	264	324	374	418	591	724	836	935	1024	1106
292	412	506	584	653	923	1131	1306	1460	1599	1727
421	595	729	842	941	1331	1631	1883	2105	2306	2491

**Flanged Globe Valve Bodies
VBF Series**



Application

The VBG series globe style valves are engineered specifically for temperature control applications requiring an equal percentage flow characteristic and a high degree of control precision. Common applications include hot water, chilled water and low pressure steam coils and heat exchangers in air handling units, chillers, boilers and cooling towers.

VBG series valves are available in 2-way and 3-way configurations, with American NPT threads. All VBG series valves are fully closed with the stem up and fully open with the stem down (stem up closed). See Figure-1 for model numbers.

All VBG series valves are operated by Erie VAP100 ANS (proportional) and VAT100ANS (3-wire floating) actuators which are ordered separately. The actuators are designed specifically for VBG series valves, and mount directly to the valves without the need for linkages or time-consuming field calibration.

Piping

VB series valves can be installed on the supply side or the return side of coils and heat exchangers of all types. For 2-way valves, the direction of flow must be into the "A" port and out of the "AB" port. For 3-way valves, the valve must be piped as a mixing valve, with the coil flow into the "A" port, the bypass flow into the "B" port, and the common outlet out of the "AB" port.

Actuator Specifications

Body Rating: 250 psi (16 bar).

Flow Characteristic: Service port equal percentage, bypass port linear.

Body Styles and Sizes: See Figure-1.

Service: Hot and chilled water, up to 50% glycol, and low pressure steam.

Valve Stroke: 0.65 in. (16.5 mm).

Seat Leakage: Service (A) port: 0.03% of Cv, bypass (B) port: 2% of Cv (3-way only).

Fluid Temperature & Pressure Limits: 14 to 274 °F (-10 to 120 °C) water, maximum. 274 °F at 21 PSIA (120 °C at 1.5 bar) steam.

Materials: Body—Cast iron, finished with corrosion resistant coating. **Stem**—Chromium nickel stainless steel.

Plug—Brass. **Stem Packing**—Double O-ring, Buna N, with Teflon wiper.

Dimensions and Shipping Weights: See Table-2.



VBG Series Valve

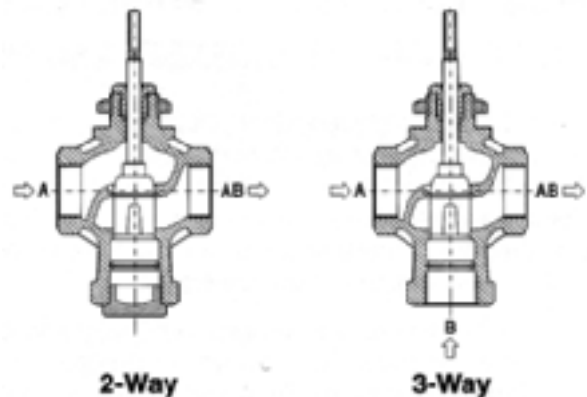

Figure 1 Valve Body Types.

VBG			
SIZE	CONNECTIONS	CONFIGURATION	
1 1/4"	125	NPT THREAD	N
1 1/2"	150		
2"	200		
		TWO WAY	2
		THREE WAY (MIX)	3

Figure 2 Ordering Chart.

Threaded Globe Valve Bodies VBG Series



TABLE 1. Flow Coefficients and Maximum Close-Off Pressure.

Valve Size	Cv	Kv	Maximum ΔP Operating PSI (bar)	Maximum ΔP Close-Off PSI (bar)
1-1/4"	19	16	30 (2)	58 (4)
1-1/2"	26	22	30 (2)	36 (2.5)
2"	47	40	30 (2)	30 (2)

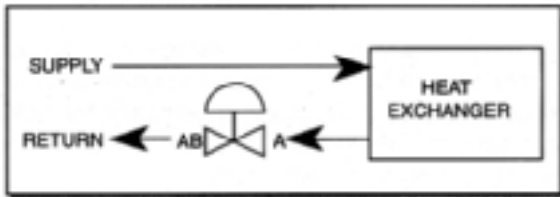

Figure 3 Two-Way Valve Piping.

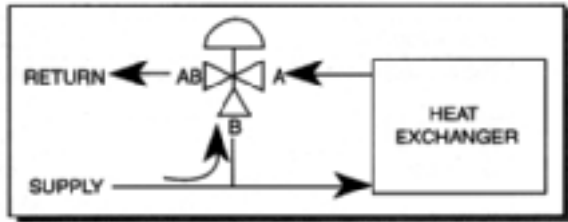

Figure 4 Three-Way Valve Piping.

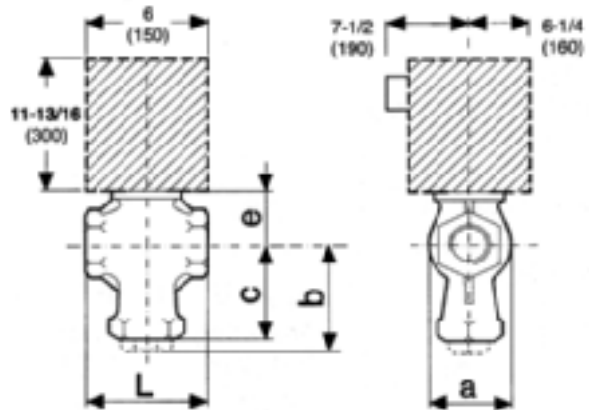

Figure 5 Dimensions.

TABLE 2. Dimensions.

Two Way Model	Three Way Model	Body Size in. (mm)	Dimensions, in. (mm)					Weight lb. (kg)
			L	A	E	B	C	
VBG125N2	VBG125N3	1-1/4 (32)	4-1/4 (108)	2-3/4 (70)	1-3/4 (43.5)	3-3/8 (85.5)	3-1/16 (78.5)	4.4 (2.0)
VBG150N2	VBG150N3	1-1/2 (38.3)	4-3/4 (120)	3-3/16 (81)	2 (51)	3-5/8 (92.5)	3-3/8 (78.5)	5.9 (2.7)
VBG200N2	VBG200N3	2 (51)	5-5/8 (142)	3-7/8 (97)	2-3/16 (54.5)	4-1/16 (104)	3-7/8 (97)	8.8 (4.0)

Application

The Boiler Boss® BB1200 series universal reset control is used to control water temperature boiler applications. The supply water is continuously adjusted up or down based on outside air temperature. As the outside air gets colder the BB1200 raises the hot water supply temperature through the dry contact output to a boiler controller. As the outside air gets warmer the BB1200 signals the boiler controller to supply cooler supply water to the heating system. This is not a boiler operating control.



BB1200

Features

- Boiler water temperature reset.
- Warm weather shutdown.
- Domestic hot water priority.
- Boiler low limit.
- Boiler supply and outdoor air sensors (OAS-1).
- LED display for boiler temperature and system settings.
- Burner LED.
- Three reset ratios.
- Test mode.

Specifications

Inputs

Power input	24 Vac, class 2, 0.25 amps maximum (6 VA) @ 50/60 Hz.
Thermostat input	24 Vac, 60 mA dry contacts originates on BB1200.
Priority zone input	10 DC, 2 mA dry contacts originates on BB1200.
Temperature sensors	100kΩ @ 77 °F (25 °C) Thermistor.

Outputs

Electrical	Burner output (dry contacts): 24 Vac pilot duty class 2, 75 VA maximum.
Mechanical	Boiler temperature range: 90 to 230 °F (32 to 110 °C).
Operating differential:	15 or 25 F degrees (8 or 14 C degrees). Field selectable.

Environment

Ambient temperature limits	Operating: -20 to 120 °F (-29 to 49 °C). Shipping and storage: -40 to 140°F (-40 to 60°C)
Humidity	85% RH, non-condensing.
Locations	NEMA Type 1.

Control Ranges

Outdoor temperature	-50 to 80 °F (-45 to 27 °C).
Boiler temperature	90 to 230 °F (32 to 110 °C).
Operating differential	15 or 25 °F (-9 to -4 °C).

Typical Applications

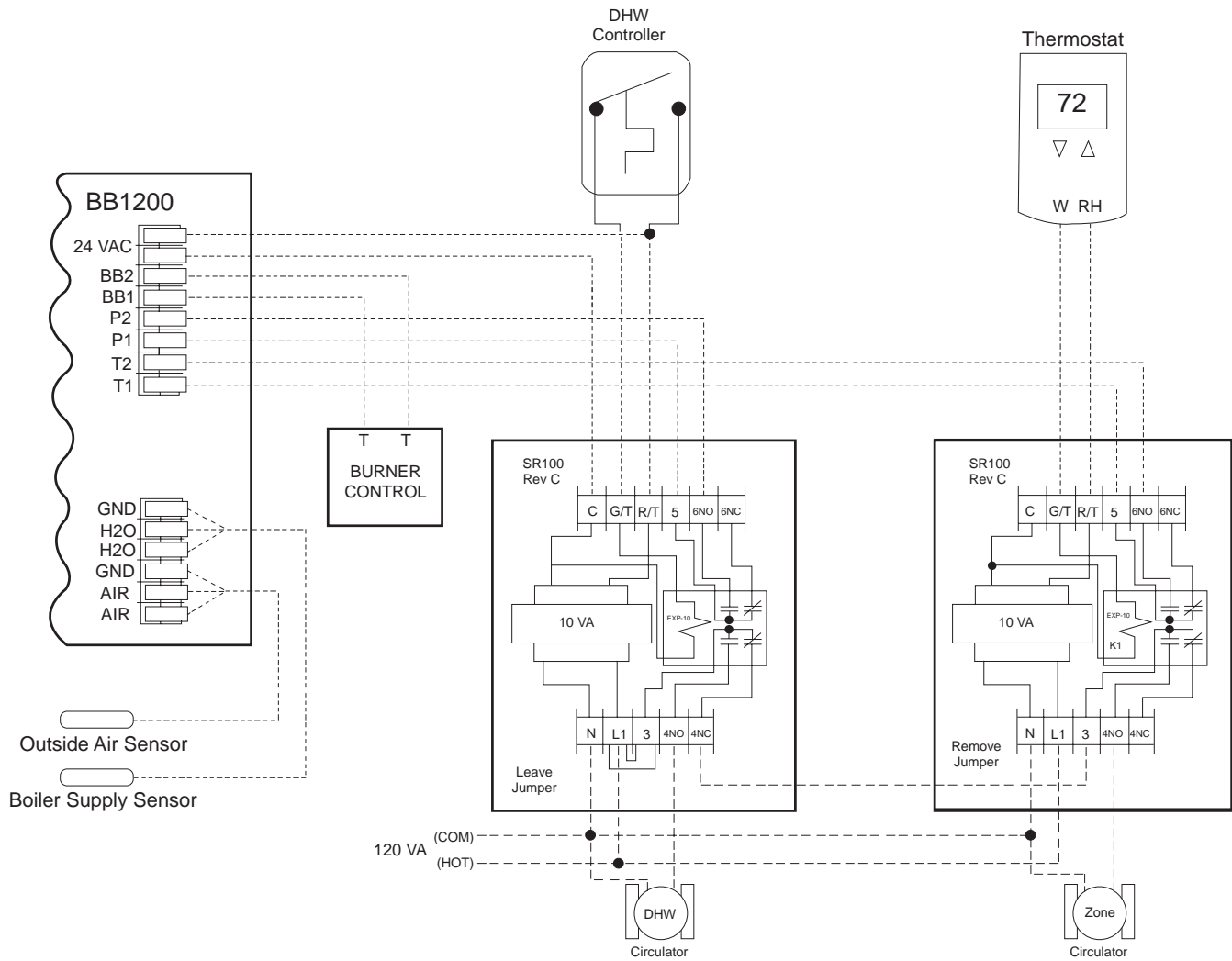

Figure 1 Typical Wiring for Boiler Boss 1200 Series With Two SR100 Relays Including Domestic Hot Water Priority.

Application

The Boiler Boss® BB2400 control is used for single stage boiler control and indirect domestic hot water.

Features

- Boiler water temperature reset control.
- Boiler water supply and outdoor air sensor.
- Boiler low limit “stand-by” or “cold start” control.
- Domestic hot water Priority Plus® control.
- Warm weather shutdown in “cold start” applications.
- Optional low water cut-off.
- Safety high limit protection.
- Burner failure protection.
- Fused circuit board.



BB2400

Model Chart

Model No.	Burner Output (Vac)	Heating Circulator Output (Vac)	DHW Priority Zone Output
BB2400-2	120	120	120 Vac
BB2400-3	24	120	120 Vac
BB2400-4	120	120	24 Vac

Specifications

Inputs

Power input	120 Vac @ 50/60 Hz 17 VA.
Internal transformer	24 Vac, 40 VA (75 VA optional).
Fuse	250 V, 15 A slow blow.
Thermostat input	60 mA @ 24 Vac.

Control Ranges

Boiler temperature range low: 90 to 200 °F (32 to 93 °C). Hi: 120 to 220 °F (49 to 104 °C).
Operating differential: 15 F degrees standard, 30 °F degrees optional.

Outputs

Electrical	Line voltage burner: 120 Vac, 60 Hz, full load 7.4 amps, locked rotor, 44.4 amps resistive 10 amps. Low voltage burner: 1 amp pilot duty @ 24 Vac 60 Hz. Circulator: 120 Vac, Full load: 7.4 amps, Locked rotor: 44.4 amps, Resistive: 10 amps. Priority circulator (BB2400-2, 3) or ZC/ZR. 1/4 hp @ 24 Vac, Full load: 3.6 amps, Locked rotor: 21.6 amps, Resistive: 5 amps. Priority zone valve (BB2400) 1 amp pilot duty @ 24 Vac 60 Hz.
-------------------	--

Environment

Ambient temperature limits	Operating: Maximum of 100 °F (39 °C). 40 to 104 °F (4 to 40 °C) Shipping and storage: -20 to 140 °F (-29 to 60 °C)
Humidity	85% RH, non-condensing.
Locations	NEMA Type 1. (IP 20)

Accessories

Model No.	Description.
BTS-1	Boiler Water/safety sensor (one included with BB2400).
OAS-1	Outside air sensor with 25 ft. shielded cable (one included with BB2400).
OAS-2	50 ft. shielded cable for OAS-1 sensor.
LWC-1	Low water sensor with LED status indicators.
EXT-75	24 Vac, 75 VA transformer.

Typical Applications

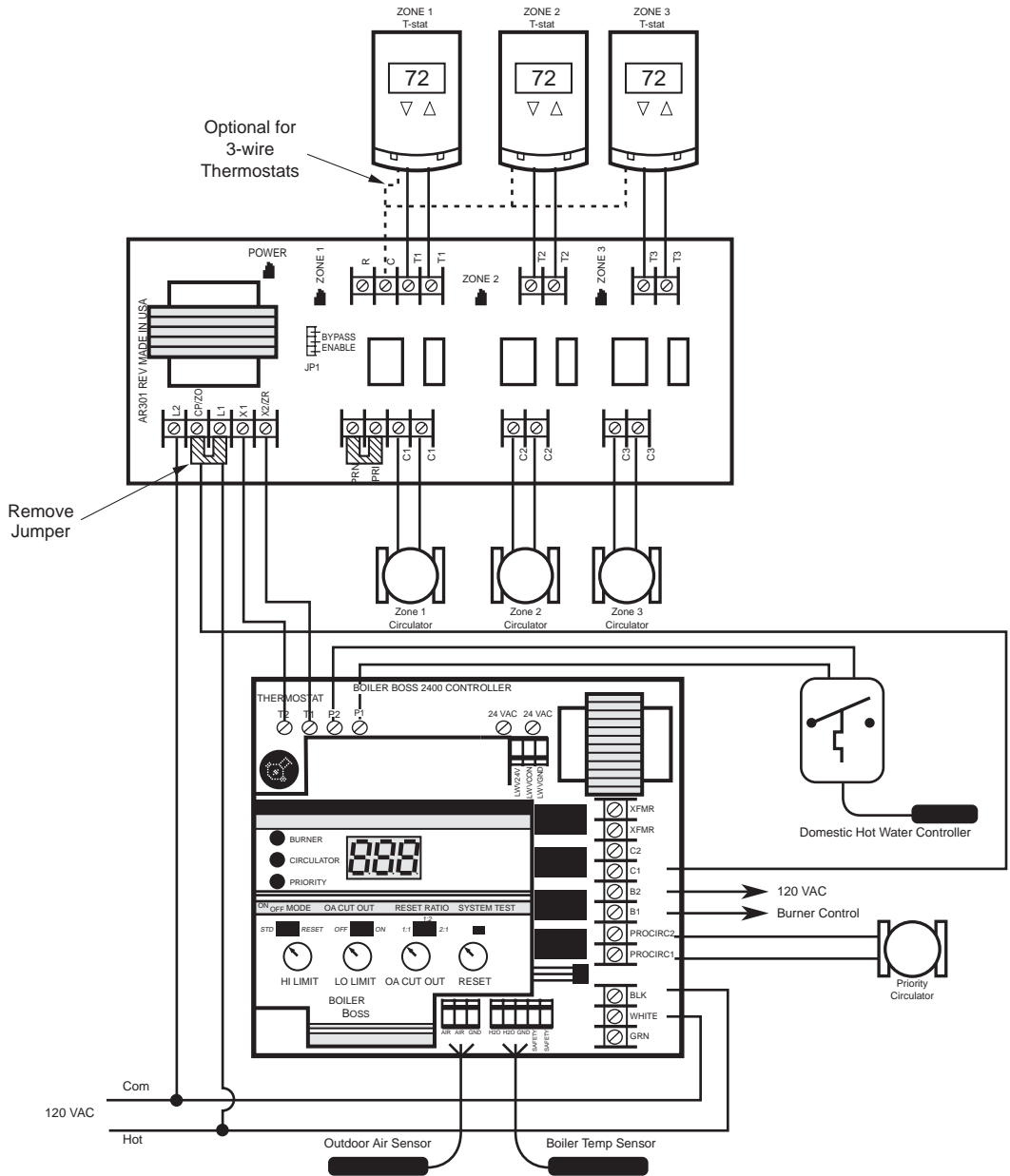

Figure 1 Typical Wiring for Boiler Boss 2400-2 with an SR301.

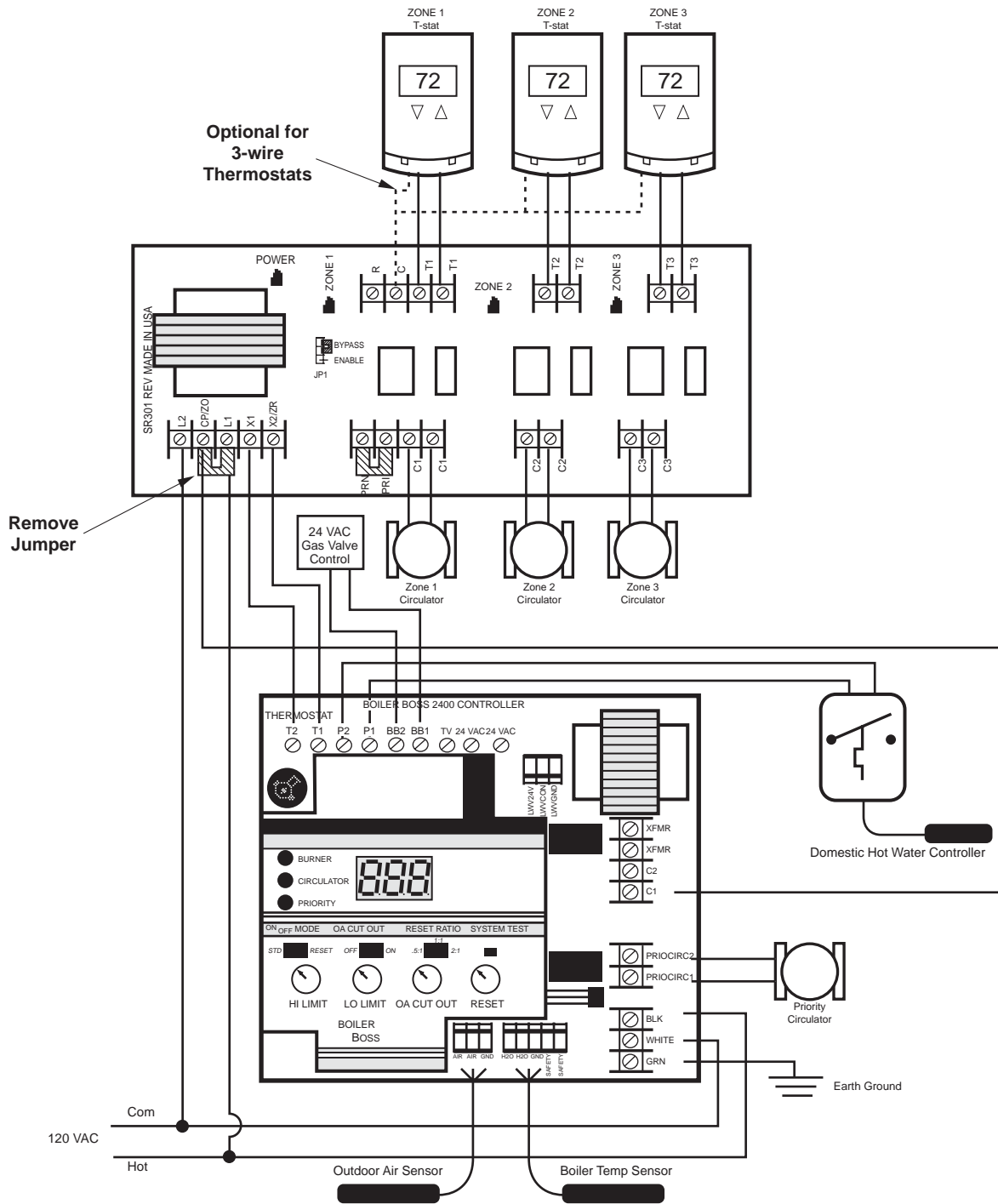

Figure 2 Typical Wiring for Boiler Boss 2400-3.



Application

The Boiler Boss® BB3000 injection pump mixing control with outdoor reset provides closed loop control of water temperature in the secondary (radiant) loop of a primary/secondary heating system.

The Boiler Boss BB3000 also protects against boiler condensation by monitoring and anticipating the boiler return water temperature.

The outdoor air and loop temperatures are displayed continuously, along with the secondary loop setpoint and pump speed.



BB3000

Features

- Microprocessor control.
- Built-in transformer and relays.
- Real application data inputs.
- Large, bright display and indicators.
- Boiler short-cycle and low temperature protection.
- Sure start pump control.
- Proxy override.

Specifications

Inputs

Power input	Switch selectable 115/230 Vac +10% -15% @ 50/60 Hz, 5 A.
Connections	See Figure 1 - Typical Wiring.
Priority zone input	Dry contact closure, 24 Vac @ 8 mA.
Heat demand	Dry contact closure, 24 Vac @ 8 mA.
Three temperature sensors	10 kΩ thermistors, -60 to 220 °F (-51 to 104 °C).
Internal transformer	24 Vac, 5 VA. Not available for external loads except as specified.
Fuse	250 V, 5 A slow blow.
Circulator fuse	250 V, 10 A slow blow.

Outputs

Electrical	Boiler control signal, Normally open relay (dry contacts for class 2 circuit only) 24 Vac, 75 VA pilot duty.
	Injection pump, Phase controlled triac at line voltage, maximum of 1/6 hp @ 115/230 Vac.
	Secondary circulator, Normally open relay maximum 1/3 hp @ 115 Vac. Maximum 1/2 hp @ 230 Vac.

Environment

Ambient temperature limits	Shipping and storage: -20 to 140 °F (-29 to 60 °C)
	Operating: 40 to 104 °F (4 to 40 °C).
	95% RH, non-condensing.
Locations	NEMA Type 1.

Agency Listings

U.S. Patent	#6,062,485.
--------------------	-------------

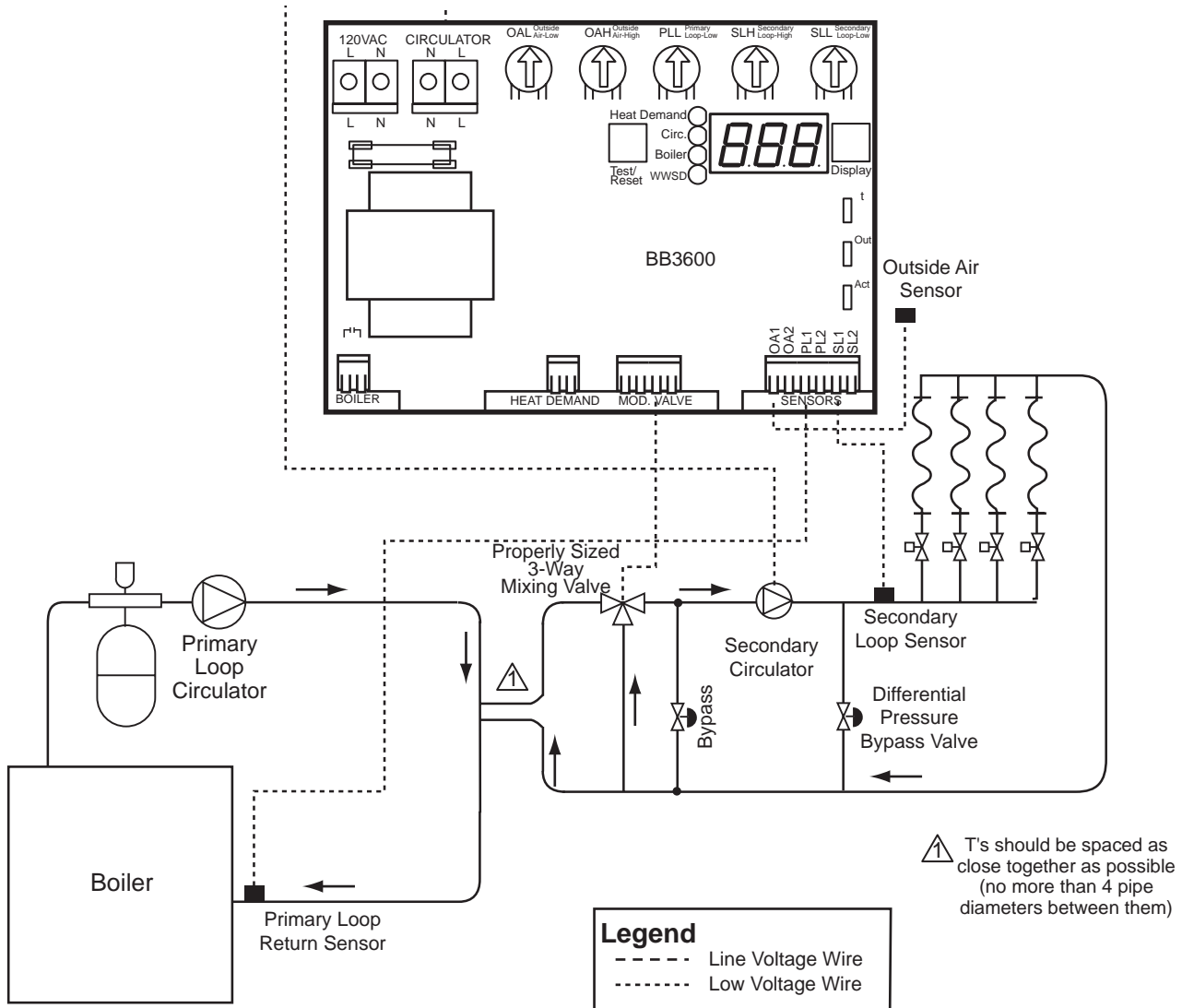

Note: The BB3600 enclosure must be earth grounded at the green ground screw.

Figure-1 Typical Wiring Boiler Boss BB3000 Series.

Application

The Boiler Boss® BB3600 mixing valve control with outdoor reset provides closed loop control of water temperature in the secondary (radiant) loop of a heating system using a proportional control three-way mixing valve.

The Boiler Boss BB3600 protects against boiler condensation by monitoring and anticipating the boiler return water temperature.

A continuously scrolling display shows the outdoor air, loop temperatures, secondary loop setpoint and valve signal value.



BB3600

Features

- Microprocessor control.
- Built-in transformer and relays.
- Real application data inputs.
- Large, bright display and indicators.
- Boiler short-cycle and low temperature protection.
- Controls a modulating valve with either a 0 to 10 V or 4 to 20 mA signal.

Specifications

Inputs

Power input	120 Vac +10% -15% @ 50/60 Hz, 20 VA.
Connections	Power: 120 Vac. Control: 24 Vac.
Heat demand	Dry contact closure, 24 Vac supplied.
Temperature sensor	10k thermistors, -60 to 220 °F (-51 to 104 °C).
Internal transformer	24 Vac, 25 VA. Not available for external loads except as specified.
Fuse	250 V, 15 A slow blow.

Outputs

Electrical	Boiler control signal: Normally open relay (dry contacts for class 2 circuit only) 24 Vac, 75 VA pilot duty. Proportional valve supply: 24 Vac, 10 VA. Proportional valve control signal: 0-10 Vdc into 500 Ω minimum, direct or reverse acting. 4-20 mA into 300 Ω maximum, direct or reverse acting. Secondary circulator: Normally open relay, 1/3 hp @ 120 Vac.
-------------------	--

Environment

Ambient temperature limits	Shipping and storage: -20 to 140 °F (-29 to 60 °C). Operating: 40 to 104 °F (4 to 40 °C).
Humidity	95% RH, non-condensing.
Locations	NEMA Type 1.

Three-Way Mixing Valve Control BB3600



Typical Applications

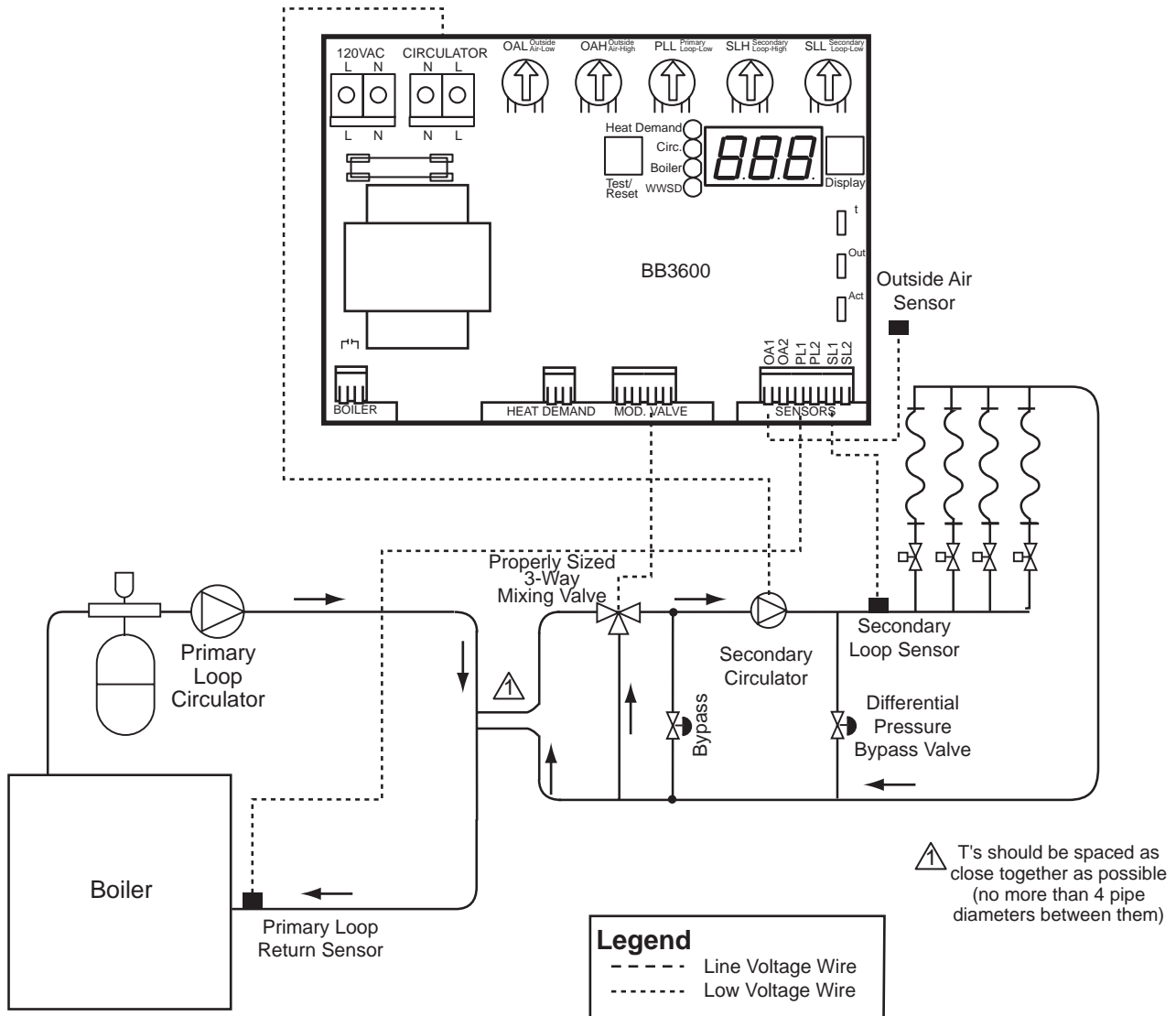

Figure-1 Typical Wiring Boiler Boss BB3600 Series.

Application

The SR100 series zone control relay incorporates a double pole/double throw relay to control a circulator and a boiler operating control in a single zone hydronic heating system.

Features

- Field replaceable relay.
- High capacity 10 VA transformer.
- Large terminal connections.
- Common 24 Vac transformer terminal.
- Standard auto-test function to test system operation.
- Field configurable for two SPDT dry contacts (shipped from factory as one 120 V SPDT contact and one SPDT dry contact).



SR100

Model Chart

Model No	Description
SR100	Single zone relay.
SR100AT	Single zone relay with auto-test.

Specifications

Inputs

Power input	120 Vac @ 50/60 Hz, 10 VA.
Thermostat	Thermostatic anticipator setting: 0.12 amps @ 24 Vac, Class 2.

Outputs

Electrical	Thermostat supply (C-R/T): 24 Vac, 0.12 A, Class 2.
	Low voltage dry contact (5-6NO or 5-6NC): 24 Vac, 8 A, Class 2.
	Line voltage dry contact (3-4NO or 3-4 NC):
	Motor: 1/3 hp @ 120 Vac,
	Motor: 1/2 hp @ 240 Vac,
	General purpose: 10 A @ 120/240 Vac,
	Resistive: 10 A @ 120 Vac

Environment

Ambient temperature limits	Shipping and storage: -20 to 140 °F (-29 to 60 °C) Operating: maximum of 120 °F (49 °C).
Humidity	85% non-condensing RH.
Locations	NEMA Type 1.
Dimensions	4-1/8 x 2-7/8 x 5-1/8 inches (105 x 73 x 130 mm).

Zone Control Relay SR100 Series



Typical Applications

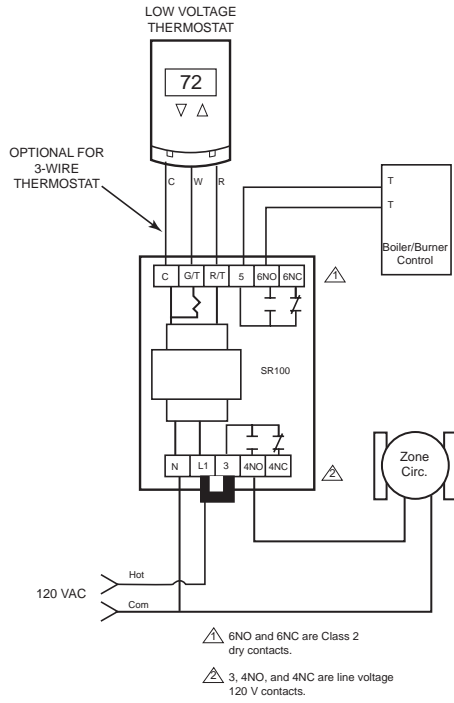

Figure 1 SR100 Relay Typical Wiring.

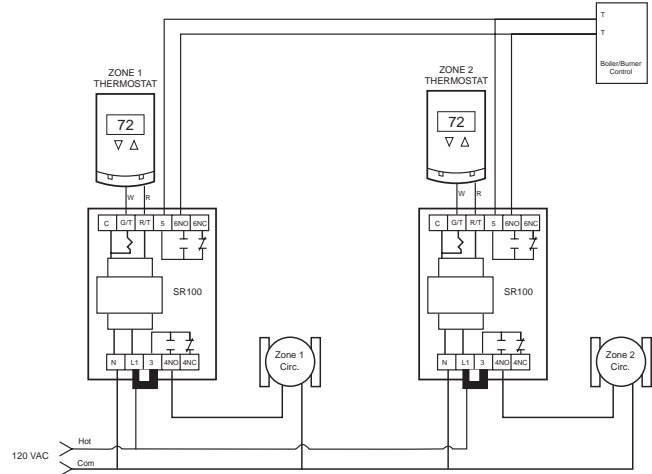

Figure 2 Multiple Zoning Using SR100 Relays.

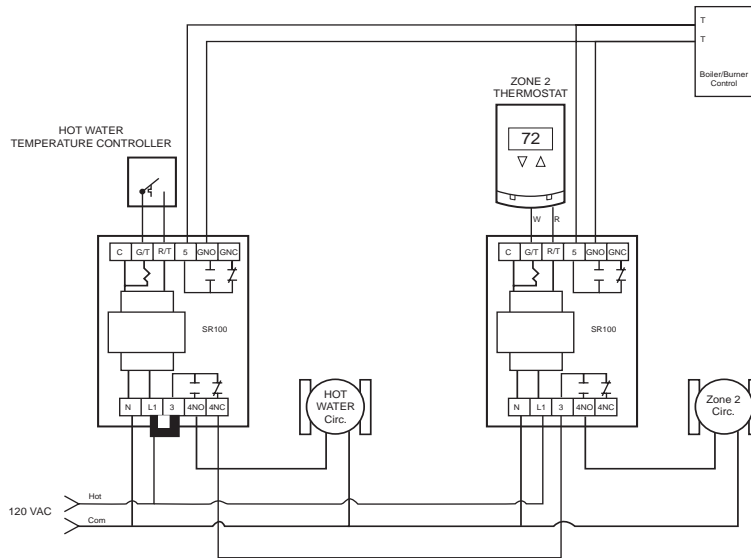

Figure 3 SR100 Series With Domestic Hot Water Priority.

Application

The SR1 multiple-zone series control relays incorporate up to six double pole/single throw relays (SR601/601AT) providing control of up to six circulators and a boiler operating control in a multi-zone hydronic heating system. Field selectable priority for zone 1 eliminates the need for additional relays to provide domestic hot water priority.



SR201

Features

- Field selectable priority zone.
- Sealed contact double pole/single throw relays.
- Field replaceable relays.
- High capacity transformer.
- LED status window.
- Zone expansion up to 10 amps of total switched line voltage.
- Common 24 Vac transformer terminal.

Model Chart

Model No	Description	Priority Plus	Dimensions in. (mm)
SR201	2 zone relay with Priority Plus. ^a	Yes	5-18 x 2-15/16 x 12-5/16 (130 x 75 x 312)
SR201B	2 zone relay with Priority. ^b	No	
SR201AT	2 zone relay with auto-test.	Yes	
SR301	3 zone relay with Priority Plus. ^a	Yes	
SR301B	3 zone relay with Priority. ^b	No	
SR301AT	3 zone relay with auto-test and Priority Plus. ^a	Yes	
SR601	4 zone expandable to 6 zone relay with Priority Plus. ^a	Yes	8 x 2-7/8 x 12-3/8 (213 x 73 x 314)
SR601B	4 zone expandable to 6 zone relay with Priority. ^b	No	
SR601AT	4 zone expandable to 6 zone relay with auto-test and Priority Plus. ^a	Yes	

^a In addition to priority only logic, Priority Plus allows non-priority heating zones to be locked out for up to one hour on a call for priority domestic hot water heating.

^b Priority only logic locks out non-priority heating zones indefinitely.

Specifications

Inputs

Power input	120 Vac @ 50/60 Hz, 10 VA (SR201/301), 1 A (SR601).
Thermostat	Thermostatic anticipator setting: Set to actual current draw of system @ 24 Vac.

Outputs

Electrical	SR201/301 Thermostat supply (R-C): 24 Vac, 5 VA, Class 2 (15 VA transformer secondary). SR601 Thermostat supply (R-C): 24 Vac, 6 VA, Class 2 (25 VA transformer secondary) Line voltage boiler output (dry contact X1-X2), and line voltage circulator outputs (C1 through C6): Motor: 1/3 hp @ 120 Vac Motor: 1/2 hp @ 240 Vac (SR201/301 only) General purpose: 10A @ 120/240 Vac (SR201/301 only) Resistive: 10 A @ 120 Vac (SR201/301), 7.4 A @ 120 Vac (SR601) CAUTION: Total load not to exceed 20 A (SR201/301) or 30 A/2hp (SR601)
-------------------	--

Environment

Ambient temperature limits	Operating: maximum of 110 °F (43 °C).
Humidity	85% non-condensing RH.
Locations	NEMA Type 1.
Dimensions	Refer to Model Chart.
Agency Listings	UL/CU

Multi-Zone Circulation Control Relay



SR201/301/601 Series

Typical Applications

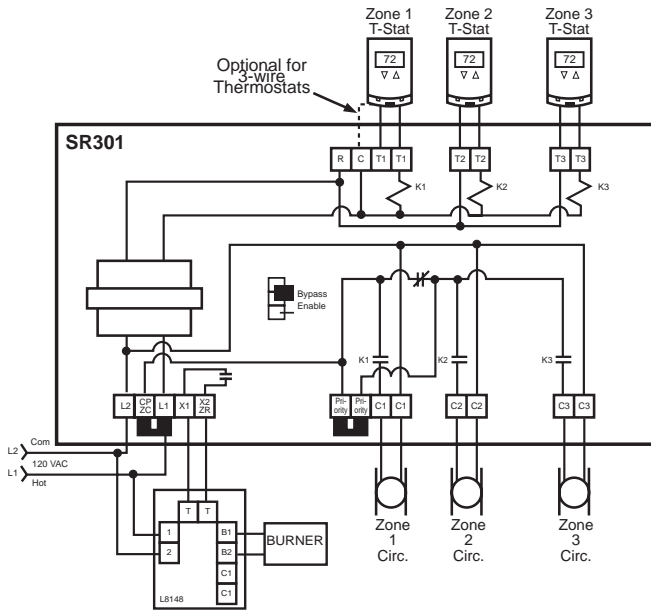

Figure 1 Typical Wiring SR301 – Boiler Controller.

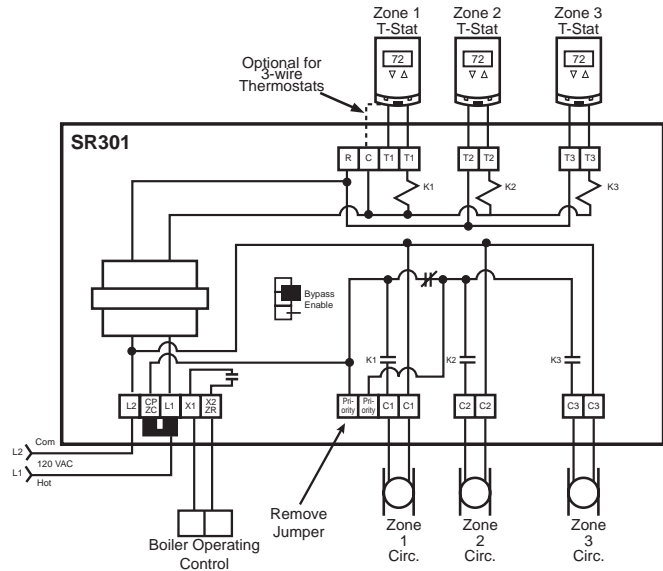

Figure 3 Typical Wiring SR301 – Domestic Hot Water Priority.

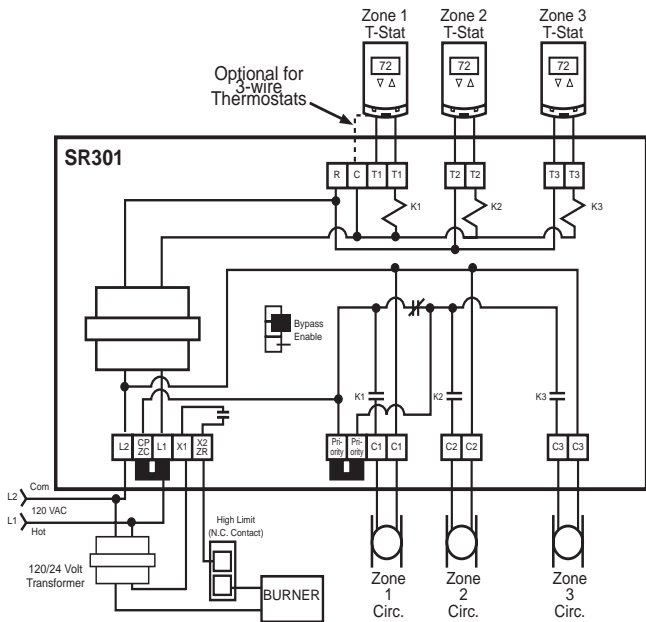

Figure 2 Typical Wiring SR301 – 24 Vac High Limit and Gas Valve.

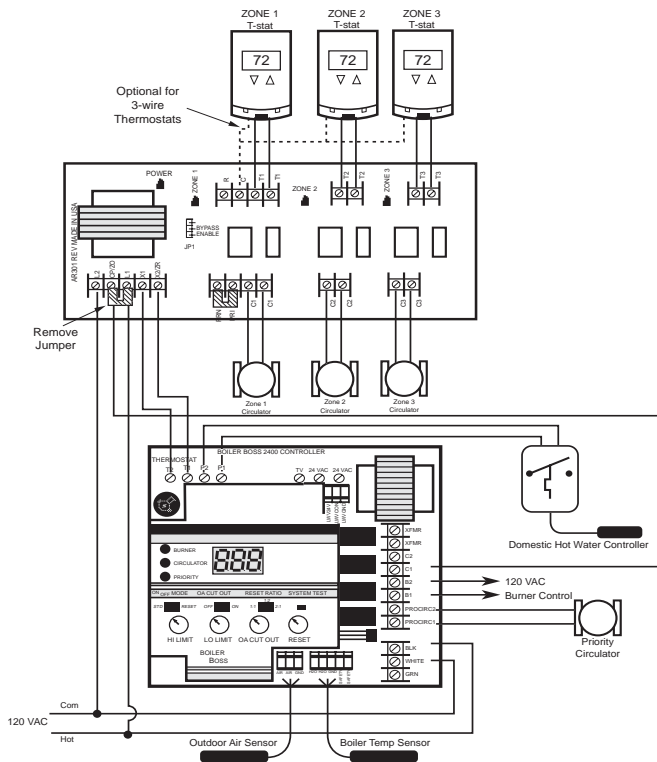

Figure 4 Typical Wiring SR301 – BB2400 Series With Domestic Hot Water Priority.

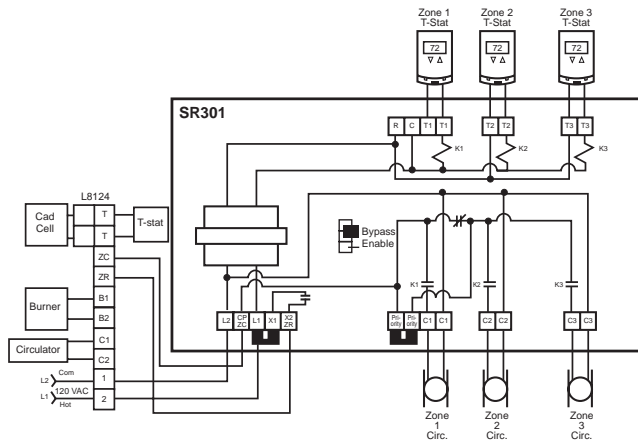

Figure 5 Typical Wiring SR301 – Tankless Coil Application.

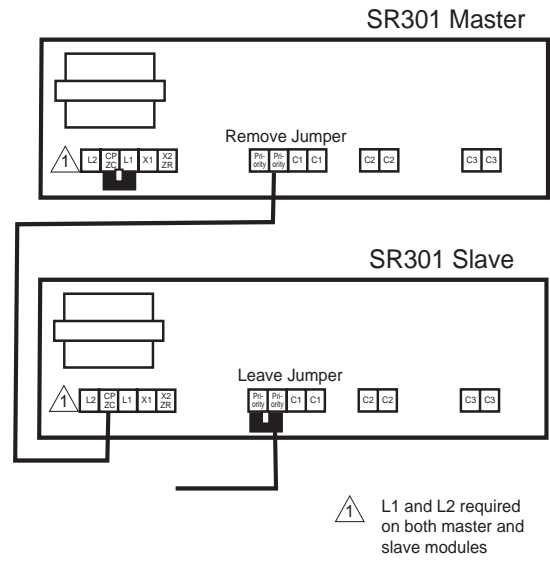

Figure 6 Typical Wiring SR301 – Zone Link Hot Water Priority.

**Multi-Zone Circulation Control
Relay
SR201/301/601 Series**



Application

The VL500 zone control system provides control of up to five zone valves a circulator and boiler control in a multi-zone hydronic heating system.

Field selectable priority for zone 1 eliminates the need for additional relays to provide domestic hot water priority.

Additional zones can be added.



VL500

Features

- Field selectable Priority Plus™ zone.
- Unlimited zone expansion. Maximum load on any serially linked VL500 slave module should not exceed 50 VA.
- Field replaceable relays.
- LED status window.
- Common 24 Vac transformer terminal.
- Field replaceable fuse.

Specifications

Inputs

Power (N-L1): 120 Vac 50/60 Hz, 100 VA.

Main fuse (F2): 10A, 125 Vac slow blow.

Thermostat/heat demand dry contacts (T1-T1 through T5-T5): 24 Vac, Class 2

Switched load is 0.05 A plus load current at corresponding "1-2" terminals.

(Power supplied by this unit - do not connect external power source)

Set thermostat anticipator per thermostat instructions to measured current.

Zone in terminals: External dry contacts rated for 24 Vac, 2.2 A (58 VA), Class 2.

Outputs

Line voltage circulator output (C1-N):

Motor: 1/3 hp @ 120 Vac

Boiler output (dry contact X1-X2):

General purpose: 3 A @ 24 Vac, Class 2

Transformer: 24 Vac, 75 VA Class 2 (total external loads limited as specified below)

Secondary fuse (F1): 3.2 A, 125 Vac slow blow.

Electrical

Zone valve outputs (5 pair of terminals 1-2): 24 Vac, Class 2

Any single zone: 0.9 A (22 VA),

Maximum total for master zone valves and thermostats: 2.7 A (65 VA),

Maximum total for slave zone valves and thermostats: 2.1 A (50 VA),

Zone out terminals: Switching capacity: 24 Vac, 2.2 A (58 VA), Class 2

Environment

Ambient temperature limits Operating: 32 to 104 °F (0 to 40 °C).

Humidity Up to 85% non-condensing.

Locations NEMA Type 1.

Dimensions 8 H x 12-3/8 W x 2-7/8 D inches (203 x 314 x 73 mm).

Typical Applications

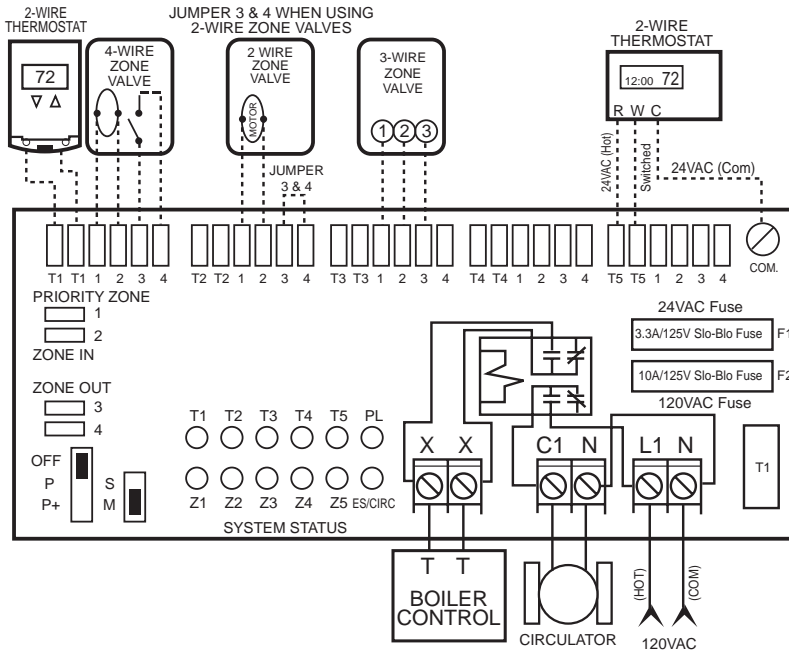

Figure 1 Typical Wiring.

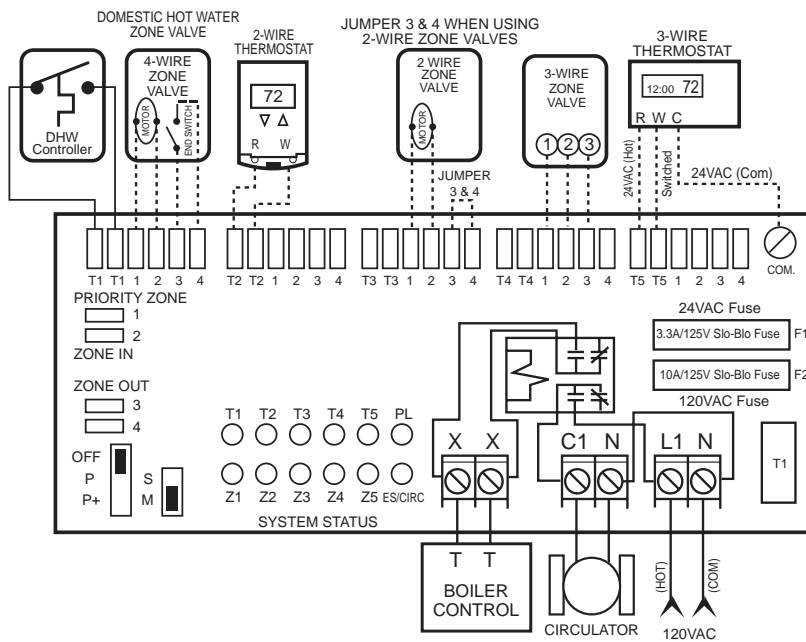
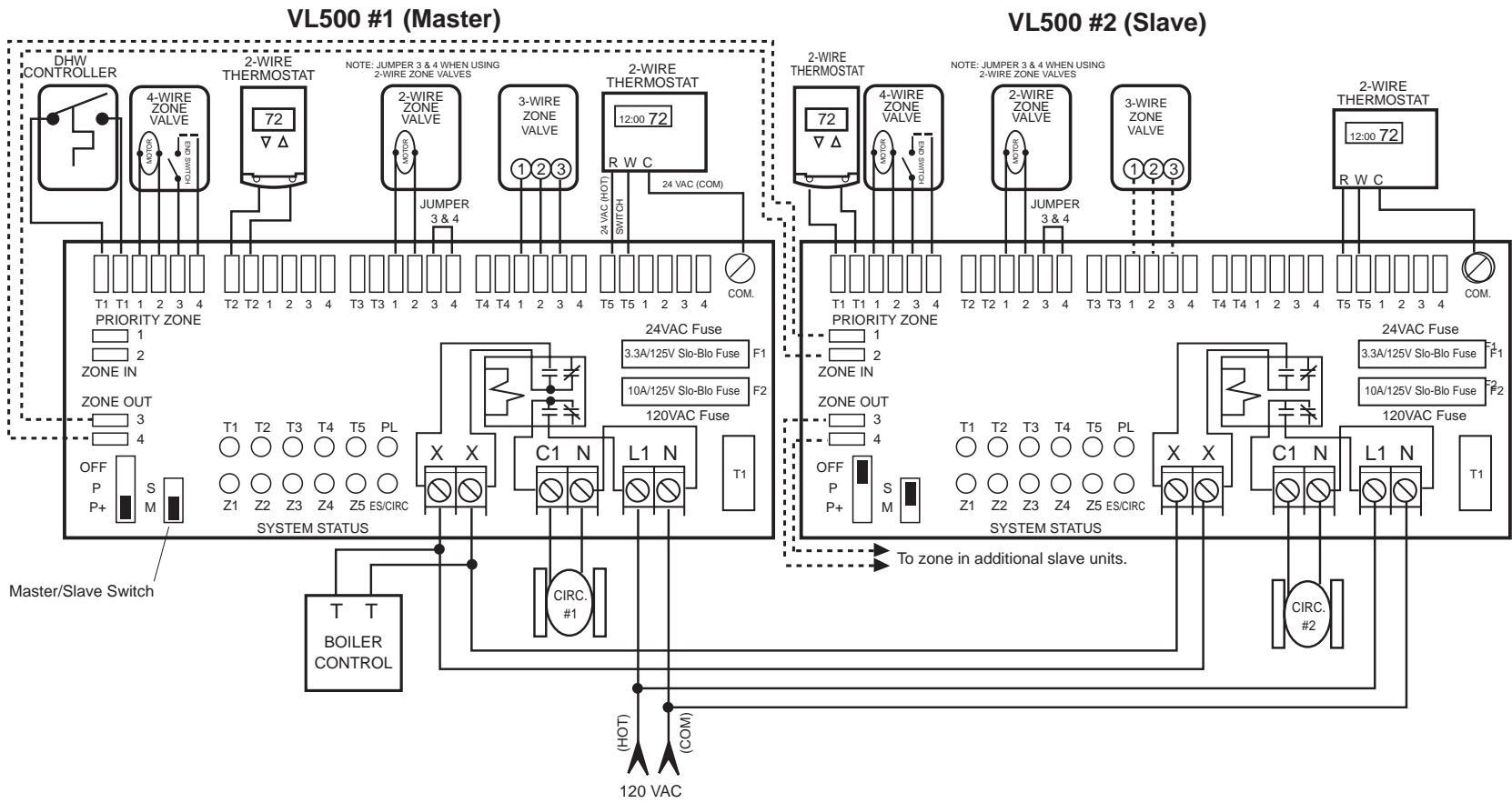

Figure 2 Typical Wiring VL500 Series with Domestic Hot Water Priority Zone, Boiler Controller and Circulator.

Figure 3 Two VL500 series with Domestic Hot Water Priority, Nine Heating Zones, Boiler and Circulator.



**Zone Valve Control Center
VL500**



Application

The WA300 hydro-air control relay incorporates several relays to provide control for up to two hydro-air systems including two air handlers/AC controller, two system heating circulators, one boiler/burner circulator, and one domestic hot water controller. Domestic hot water priority zone eliminates the need for additional relays to provide domestic hot water for indirect fired hot water tanks. The thermostats used with the WA300 must power the fan on when the heat output is powered.

Note: Thermostats used with the WA300 must switch on the heat and fan outputs when heat is called for.



WA300

Features

- Capable of controlling two hydro-air systems in one relay package.
- Selectable fan delay of 90 or 180 seconds in heat mode.
- Common 24 Vac transformer terminal provides compatibility with electronic thermostats.
- Field replaceable circulator relays.
- Large terminal connections.
- Expandable up to 4 zones with the addition of a second WA300.

Specifications

Inputs

Power input	Circulators: 120 Vac @ 50/60 Hz. Fan centers: 24 Vac @ 50/60 Hz.
--------------------	---

Connections	See Figure 1 - Typical Wiring.
--------------------	--------------------------------

Outputs

Electrical	Thermostatic anticipator setting: Set to actual current draw of system @ 24 Vac.
	Circulator relay rating: 1/4 hp @ 120 Vac, Full load: 6 amps; Locked rotor: 43.2 amps; Resistive: 6 amps.
	Fan center switch rating: 1 amp @ 24 Vac.

Environment

Ambient temperature limits	Operating: 120 °F (49 °C) maximum.
-----------------------------------	------------------------------------

Humidity	5 to 95% RH, non-condensing.
-----------------	------------------------------

Locations	NEMA Type 1.
------------------	--------------

Dimensions	5-1/8 H x 12-5/16 W x 2-15/16 D inches (130 x 312 x 75 mm).
-------------------	---

Two Zone Hydro-Air Relay WA300



Typical Applications

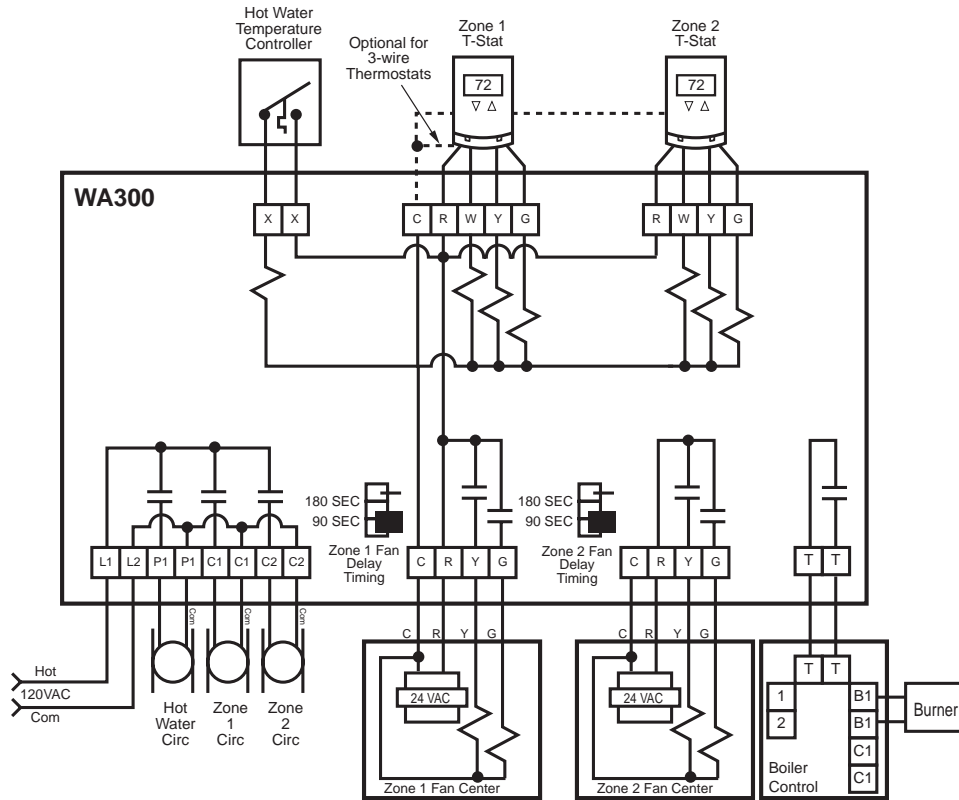

Figure 1 Typical Wiring WA300 – Boiler Controller and Two Fan Centers With Domestic Hot Water Priority.

Application

The T155 series thermostat provides on/off control for low voltage and line voltage control of valves, relays and fan motors. Applications include two-pipe and four-pipe fan coil units, ventilators, and air quality operators.

Features

- Manual or automatic changeover models.
- Line voltage 3-speed fan control.
- Continuous or cycling fan operation (cycling fan operation requires additional relay or relays).
- Remote sensor capability.
- Handles all supply voltages from 24 to 277 Vac at 50/60 Hz (fan and system voltage must be the same).



T155

Model Chart.

Model No.	Outputs	Changeover	Fan Control	System Switches
TA155-010	Dual	Manual	Hi-Med-Lo	Heat-Off-Cool
TA155-017	Single	N/A	Hi-Med-Lo	On-Off
TA155-018	Single	N/A	None	None
TB155-010	Dual	Automatic ^a	Hi-Med-Lo	On-Off
TB155-015	Dual	Automatic ^a	None	None

^a Auto changeover models have 4 F degree deadband between heating and cooling.

TABLE 1. Fan and System Switch Rating.

Voltage ^a	Inductive		Resistive Amps	Pilot Duty
	FLA	LRA		
24	N/A	N/A	N/A	24 VA
120	5.8	34.8	6.0	125 VA
240	2.9	17.4	5.0	125 VA
277	2.4	14.4	4.2	125 VA

^a Fan and system must share same voltage.

Electronic On/Off Thermostat/Controller T155 Series



Specifications

Inputs	
Power input	24 to 277 Vac @ 50/60 Hz.
Power consumption	0.88 watts at maximum.
Connections	Power: Up to 14 AWG wire.
	Control: Up to 14 AWG wire.
Outputs	
Electrical	Thermostatic switch ratings: 10 VA @ 24 Vac, Pilot duty 20 VA @ 120 - 277 Vac.
Control ranges	Operating differential: 1 F degree (0.6 C degree).
	Changeover deadband (TB155 only): 4 F degrees (2.2 C degrees).
	Deadband (TA155-017 and TA155-018): 0 F degrees (0 C degrees).
Mechanical	Setpoint adjustment range: 50 to 90 °F (10 to 32 °C).
	Material: Rigid vinyl. Finish: Cool gray.
Environment	
Ambient temperature limits	Shipping and storage: -30 to 130 °F (-34 to 55 °C). Operating: 32 to 130 °F (0 to 55 °C).
Humidity	Non-condensing.
Locations	NEMA Type 1.
Dimensions	4-1/2 H x 2-3/4 W x 1 D inches (114 x 79 x 25 mm).
Agency Listings	CE compliant.

Accessories

Model No.	Description.
65345	4-3/4 x 4-3/4" adapter plate.
65406	Remote sensor, 60" leads 10k W @ 77 °F (25 °C).
65409	Fahrenheit set point dial, 50 to 90 °F
65410	Celsius set point dial, 10 to 34 °C.
65170	Warmer/cooler set point dial.
65860	Set point dial stop kit.
680-243	Auto seasonal changeover switch.
680-243-5	36" Changeover switch.
680-243-6	36" Changeover switch with conduit connection.

Typical Applications

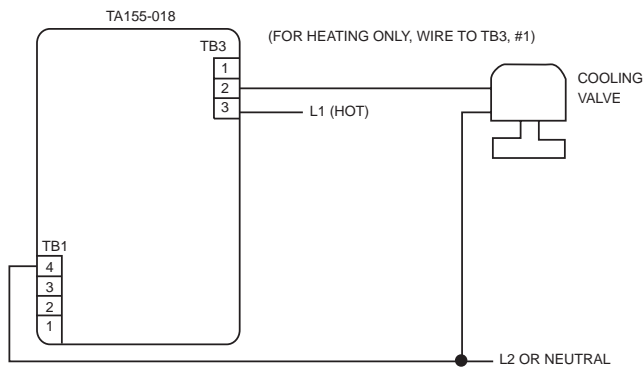

Figure 1 Typical 2-Pipe Cooling or Heating Only.
No Fan Connections.

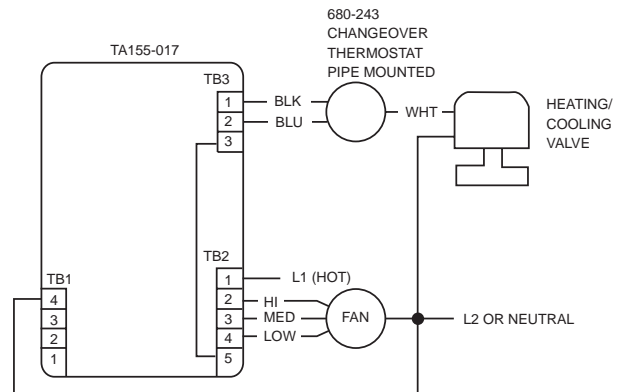

Figure 2 Typical 2-Pipe Heating/Cooling/Continuous Fan with
System Switch off, Fan is Off.

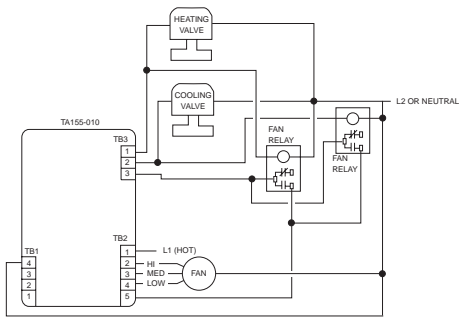

Figure 3 Typical 4-Pipe Heating/Cooling Fan cycles with Demand for Heating or Cooling. With System Switch Off, Fan is Off.

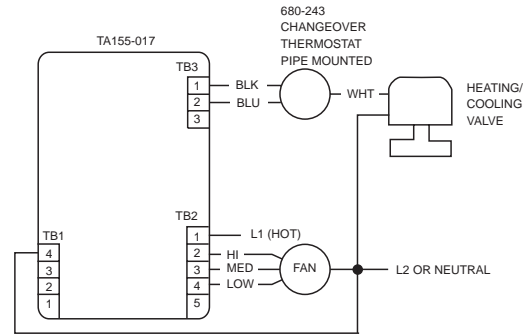

Figure 4 Typical 2-Pipe Heating/Cooling Fan Runs with System Switch On or Off.

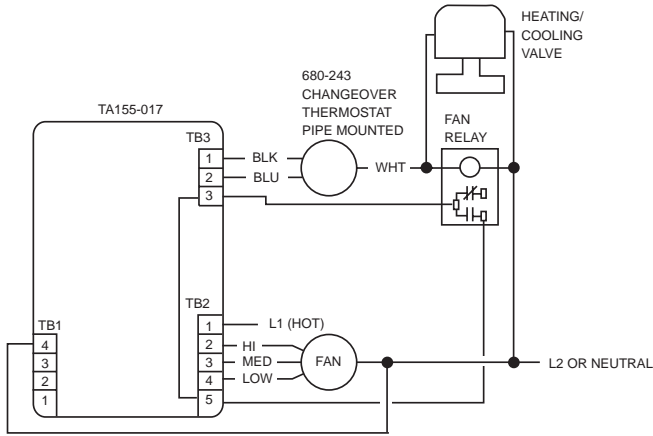

Figure 5 Typical 2-Pipe Heating/Cooling Fan Cycles with Demand for Heating or Cooling. With System Switch Off, Fan is Off.

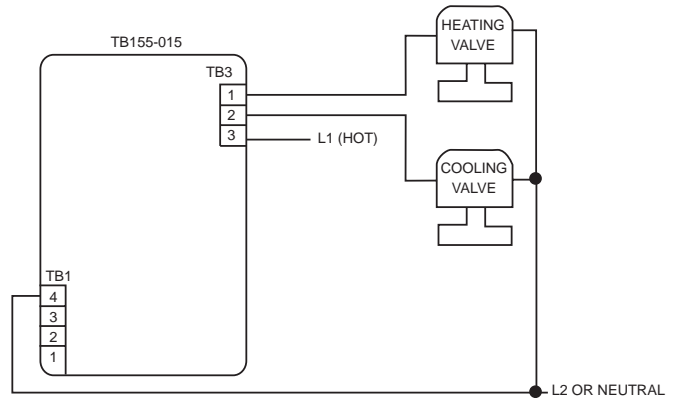

Figure 6 Typical 4-Pipe Heating/Cooling. No Fan Connections.

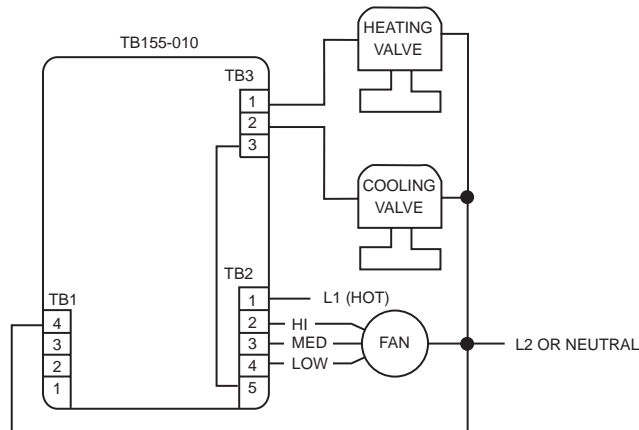

Figure 7 Typical 4-Pipe Heating/Cooling Fan Runs Continuously with System Switch On. With System Switch Off, Fan is Off.

**Electronic On/Off
Thermostat/Controller
T155 Series**



Application

The T158 series microprocessor based thermostat/controller with digital display provides 3-wire floating, on/off control, or a combination of 3-wire floating and on/off control. This series controls a variety of two-pipe and four-pipe fan coil units, air handling units, and various heating and cooling applications. The microprocessor combines a proportional integral control algorithm with adaptive logic. This provides control without the need for tuning or calibrating the control algorithm in the field.



T158

Features

- Heating and cooling outputs are individually configurable for 3-wire floating or on/off control in the normally open or normally closed modes.
- Line voltage continuous 3-speed fan control.
- Manual or automatic changeover.
- Remote setback capability from a time clock or facility management system.
- Fahrenheit or Celsius display capability.
- Built-in purge cycle assists the controller to determine if the controlling agent is providing heating or cooling.
- Microprocessor eliminates the necessity for tuning or calibration.
- Setpoint can be calibrated to within ± 5 F degrees (2.5 C degrees).

Model Chart

Model No. ^{abc}	Outputs	Control Signal Options	Fan Control	Remote Sensor ^d	Setback	System Switches
TA158-001	Dual	6	None	Yes	Yes	Off-Auto-Heat-Cool
TA158-002	Dual	6	Off-Hi-Med-Lo	Yes	Yes	Off-Auto-Heat-Cool
TB158-001	Dual	1, 2, 3, 4, 5, 6	None	Yes	Yes	Off-Auto-Heat-Cool
TB158-002	Dual	1, 2, 3, 4, 5, 6	Off-Hi-Med-Lo	Yes	Yes	Off-Auto-Heat-Cool
TB158-003	Single	5, 7	Off-Hi-Med-Lo	Yes	Yes	Off-Heat/Off-Cool
TB158-007	Single	5, 7	None	Yes	Yes	None
TB158-015	Single	5, 7	None	Yes	Yes	Off-Heat/Off-Cool
TB158-017	Dual	1, 2, 3, 4, 5, 6	Off/On	Yes	Yes	Off-Auto-Heat-Cool
TB158-018	Single	5, 7	Off/On	Yes	Yes	Off-Heat/Off-Cool

1. 3-wire floating single stage cooling and 3-wire floating single stage heating.
2. 3-wire floating cooling and two stage on/off heating.
3. Single stage on/off cooling, on/off fan control, and 3-wire floating single stage heating.
4. On/off single stage cooling, on/off single stage heating and fan control.
5. 3-wire floating single stage cooling or single stage heating.
6. On/off single stage cooling and on/off single stage heating.
7. On/off single stage cooling or on/off single stage heating.

- ^a Do not use with actuators in which the motor is driven by DC voltage.
^b Do not use with actuators which have position memory on power loss.
^c Actuator must full stroke open or closed in 1 to 3 minutes.
^d Remote sensor ordered separately.

TABLE 1. Fan Switch Rating

Voltage	Inductive		Resistive Amps	Pilot Duty
	FLA	LRA		
24	N/A	N/A	N/A	24 VA
120	5.8	34.8	6.0	125 VA
240	2.9	17.4	5.0	125 VA
277	2.4	14.4	4.2	125 VA

Digital, Three-Wire Floating Thermostat/Controller



T158 Series

Specifications

Inputs	
Power input	20 to 28 Vac, nominal 24 VA.
Power consumption	25 mA maximum at 24 Vac.
Connections	Power: Up to 14 AWG wire. Control: Up to 14 AWG wire.
Outputs	
Electrical	Thermostatic switch ratings: 10 VA @ 24 Vac. System switch rating: 10 VA @ 24 Vac.
Control ranges	Display range: 32 to 99 °F (0 to 37 °C). Proportional band: 2 °F (1.1°C). Changeover deadband: 3 °F (1.6 °C). Setpoint adjustment range: 50 to 90 °F (10 to 32 °C).
Mechanical	Material: Rigid vinyl. Finish: Cool gray.
Environment	
Ambient temperature limits	Shipping and storage: -30 °F to 130°F (-34 to 55 °C). Operating: 32 to 130 °F (0 to 55 °C).
Humidity	95% Non-condensing.
Locations	NEMA Type 1.
Dimensions	2-3/4 H x 4-1/2 W x 1-1/8 D inches (79 x 114 x 28 mm).
Agency Listings	CE compliant.

Accessories

Model No.	Description.
65345	4-3/4" x 4-3/4" adapter plate.
65406	Remote sensor, 60" leads 10k Ω @ 7 7°F (25 °C).

Typical Applications

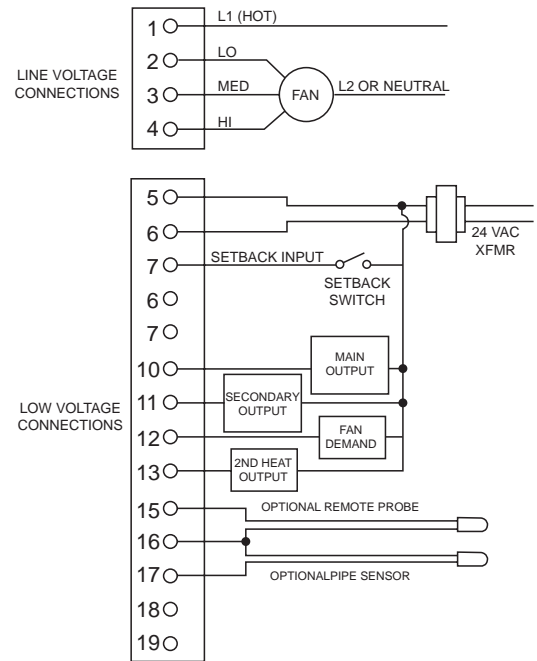
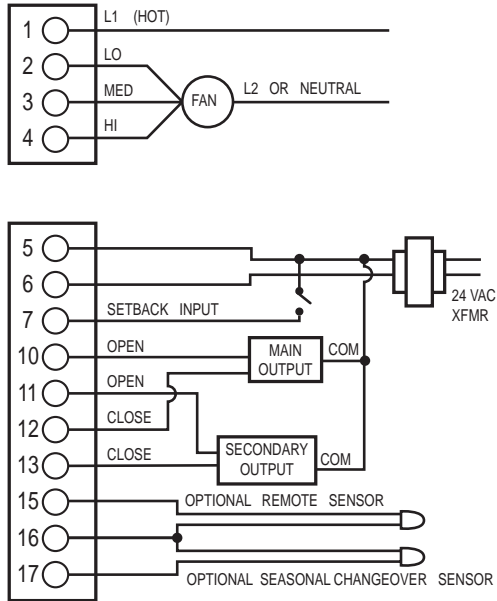
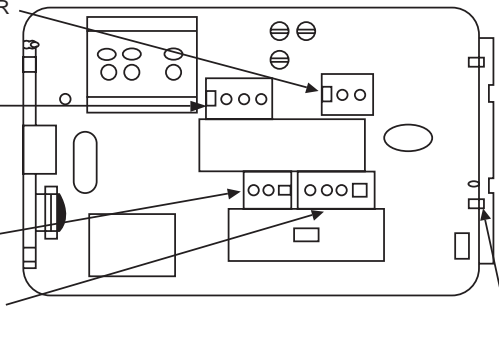

Figure 1 Typical Wiring for 3-Wire Floating Control

Figure 2 Typical Wiring for On/Off Control

CONNECTIONS

- 15 REMOTE SENSOR
- 16 REMOTE SENSOR & CHANGEOVER SENSOR
- 17 CHANGEOVER SENSOR
- 10 MAIN OPEN
- 11 SECONDARY OPEN
- 12 MAIN CLOSE
- 13 SECONDARY CLOSE
- 5 24 VAC COMMON
- 6 24 VAC HOT
- 7 SETBACK INPUT
- 1 L1 (HOT)
- 2 FAN LOW/CONTINUOUS
- 3 FAN MED
- 4 FAN HIGH



JP1: REMOVE TO ALLOW USE OF REMOTE PROBE

Figure 3 Terminal Description

**Digital, Three-Wire Floating
Thermostat/Controller
T158 Series**



Application

The T168 series microprocessor based thermostat/controller provides 0 to 10 Vdc or 4 to 20 mA control. This series controls a variety of two-pipe and four-pipe fan coil units, air handling units, and various heating and cooling applications. The microprocessor combines a proportional integral control algorithm with adaptive logic. This provides control without the need for tuning or calibrating the control algorithm in the field.



T168-001

Features

- 0 to 10 Vdc or 4 to 20 mA heat and cool outputs.
- Low voltage fan cycling operation with demand output.
- Remote setback capability from a time clock or facility management system.
- Auxiliary heat function.
- Remote and/or seasonal changeover sensor optional.
- Fahrenheit or Celsius display capability.
- In two pipe mode a built-in purge cycle assists the controller to determine if the controlling agent is providing heating or cooling.
- Line voltage continuous on/off or 3-speed fan control.

Model Chart

Model No.	Outputs	Fan Control	Demand Output	Auxiliary Heat	Setback	System Modes
TA168-001	Dual	None	No	Yes	Yes	Off-Auto-Heat-Cool
TA168-002	Dual	Off-Hi-Med-Lo	Yes	Yes	Yes	Off-Auto-Heat-Cool
TA168-003	Single	Off-Hi-Med-Lo	Yes	No	Yes	Off-Heat/Off-Cool
TA168-004	Single	None	No	No	Yes	Off-Heat/Off-Cool
TA168-005	Single	None	Yes	No	Yes	Off-Heat/Off-Cool
TA168-006	Dual	None	Yes	Yes	Yes	Off-Auto-Heat-Cool
TA168-007	Single	Off/On	Yes	No	Yes	Off-Heat/Off-Cool
TA168-008	Dual	Off/On	Yes	No	Yes	Off-Auto-Heat-Cool

TABLE 1. Fan Switch Rating

Voltage	Inductive		Resistive Amps	Pilot Duty
	FLA	LRA		
24	N/A	N/A	N/A	24 VA
120	5.8	34.8	6.0	125 VA
240	2.9	17.4	5.0	125 VA
277	2.4	14.4	4.2	125 VA

Digital, Proportional Thermostat/Controller



T168 Series

Specifications

Inputs	
Power input	20 to 28 Vac, nominal 24 Vac.
Power Consumption	25 mA maximum at 24 Vac.
Outputs	
Electrical	Thermostatic switch rating: 10 VA @ 24 Vac.
	Electrical connections: Terminal strip with screw-down terminals.
Control signals	0 to 10 Vdc 1000 Ω minimum.
	4 to 20 mA 100 - 600 ohms.
Control ranges	Setpoint adjustment range: 50 to 90 °F (10 to 32 °C)
	Display range: 32 to 99 °F (0 to 37 °C).
	Proportional band: 2 F degrees (1.1 C degrees).
	Changeover deadband: 3 F degrees (1.6 C degrees)
Mechanical	Material: Rigid vinyl.
	Finish: Cool gray.
Environment	
Ambient temperature limits	Shipping and storage: -30 to 130 °F (-34 to 55 °C).
	Operating: 32 to 130 °F (0 to 55 °C).
Humidity	Non-condensing.
Locations	NEMA Type 1.
Dimensions	2-3/4 H x 4-1/2 W x 1-1/8 D inches (79 x 114 x 28 mm).
Agency Listings	CE compliant.

Accessories

Model No.	Description.
65345	4-3/4" x 4-3/4" adapter plate.
65406	Remote sensor, 60" leads 10k W @ 77 °F (25 °C)

Typical Applications

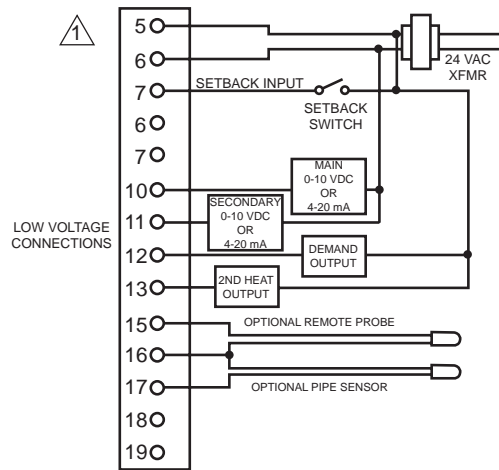
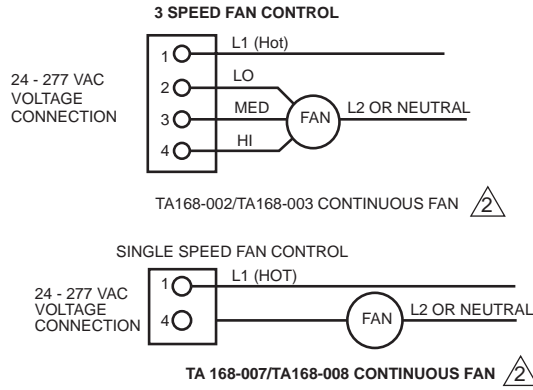

¹ For main and secondary outputs, Terminal 6 is the common and Terminal 5 is the power. For setback, demand and auxillary heat outputs Terminal 5 is the common and Terminal 6 is the power.

² For demand fan control, power a 24V fan relay using Terminal 12 as the output.

Figure 1 Typical Wiring for Proportional Control.

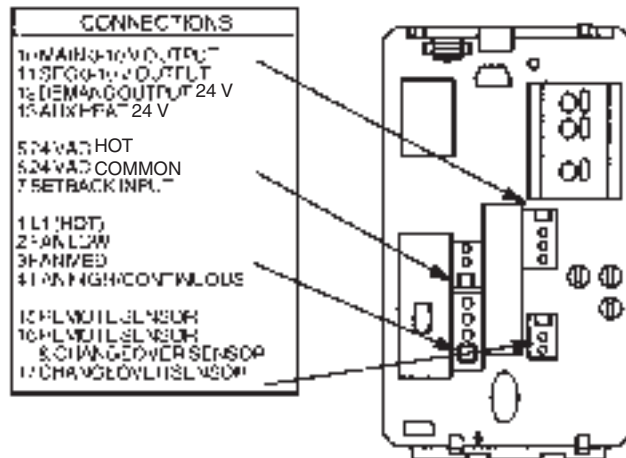

Figure 2 Terminal Description.

**Digital, Proportional
Thermostat/Controller
T168 Series**



Application

T200 series thermostats provide temperature control on a variety of heating, cooling and single stage heat pump applications.

The large LCD window displays room temperature including 1/5th of a degree increments indicated by a series of up to 5 dashes. The system heat output cycles on a 1 or 2 F degree field selectable differential. The cool output differential is fixed at 2 F degrees. The setpoint is displayed and changed by pressing one of the setpoint buttons up or down. Installation is simplified by having all of the field wires mounted to the separate wall plate.

This is a powered thermostat, which must receive 75 mA of power at all times.



T201

Features

- LCD window display.
- Jumper selectable 5 minute time delay for heating and cooling application.
- Mechanical contact for freeze protection (optional).

Model Chart

Model No.	Control Outputs	Fan Control ^a	System Switch ^a	Changeover	Mechanical Contact	B & O Terminals
T201	Heating Only	None	Heat/Off	None	No	No
T201-FP ^b	Heating Only	None	Heat/Off	None	Yes	No
T204	Cooling Only	On/Auto	Cool/Off	None	No	No
T205	Cooling and Heating	On/Auto	Cool/Off/Heat	Manual	No	No
T205-FP ^b	Cooling and Heating	On/Auto	Cool/Off/Heat	Manual	Yes	No
T207	Cooling and Heating	On/Auto	Cool/Off/Heat	Manual	No	Yes
T207-FP ^b	Cooling and Heating	On/Auto	Cool/Off/Heat	Manual	Yes	Yes

^a Fan switch operates independent of system switch unless relays are added.

^b Freeze protection, at 40 °F the thermostat mechanically latches heat with output.

Specifications

Inputs

Power input 20 to 32 Vac, 75 mA to 1.2 amps (power-stealing thermostat, 75 mA required at all times. 250W, 5 watt resistor may be needed).

Outputs

Electrical Battery: Setpoint backup Energizer 357 or similar (battery included).

Setpoint range: 50 to 86 °F (10 to 30 °C).

Control ranges Operating differential: Heating 1 or 2 F degrees (0.6 or 1.1 C degrees), Cooling 2 F degrees (1.1 C degrees).

Mechanical Material: Rigid vinyl.

Finish: Off-white.

Environment

Ambient temperature limits Shipping and storage: -40 to 125 °F (-40 to 52 °C).
Operating: 40 to 125 °F (5 to 53 °C).

Humidity 95% non-condensing.

Locations NEMA Type 1.

Dimensions

Thermostat: 4 H x 2-1/2 W inches (102 x 64 mm).

Thermostat base and adaptor plate: 4-3/4 H x 4-1/4 W inches (121 x 108 mm).

Typical Applications

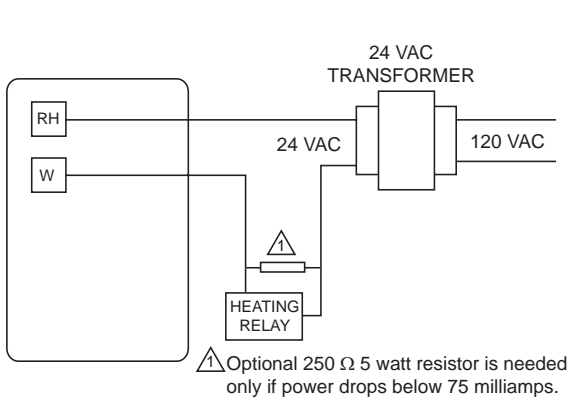

Figure 1 T201 Wiring to Heating System With Single Transformer.

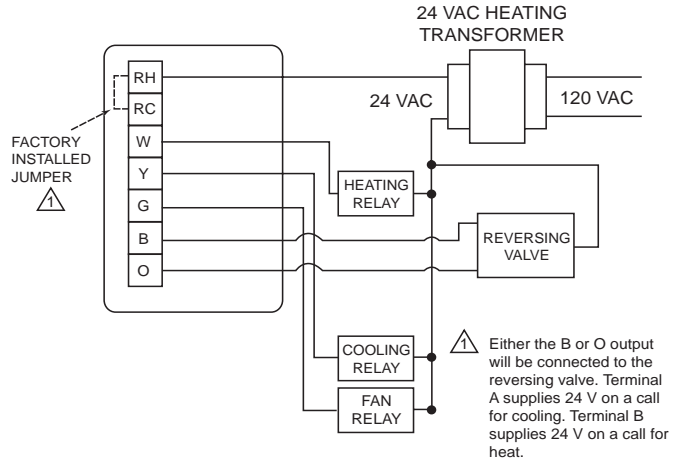

Figure 2 T207 Wiring to Heating/Cooling System With Single Transformer and Reversing Valve.

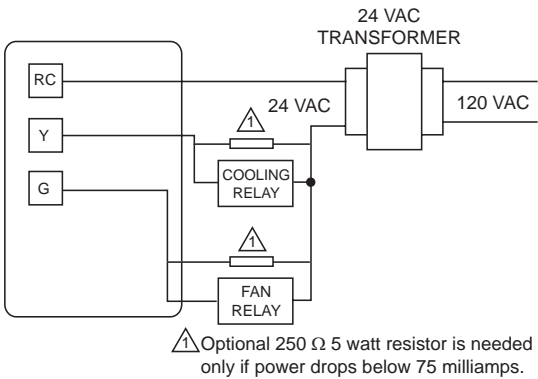

Figure 3 T204 Wiring to Heating/Cooling System With Single Transformer.

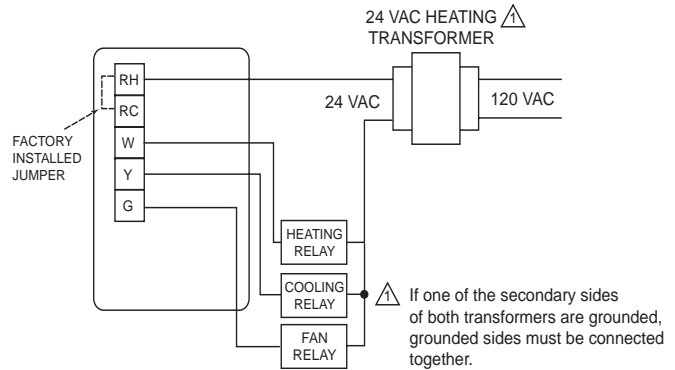

Figure 4 T205 Wiring To Heating/Cooling System With Single Transformer.

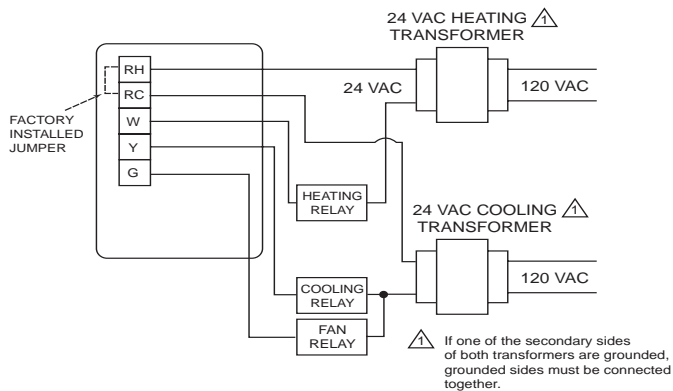

Figure 5 T205 Wiring To Heating/Cooling System With Dual Transformer.

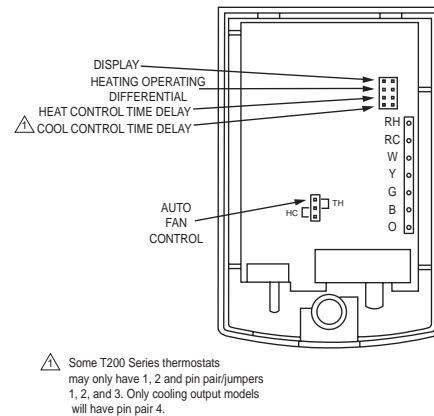

Figure 6 Terminal Identification.

Application

The T500 series thermostats are available in four basic models for low and line voltage control of valves, relays, and fan motors in fan coil and packaged units for commercial, industrial, and residential installations. Special order option allows heating and/or cooling pilot light indication.

Features

- Set point dial stop (optional).
- LED status indicators (optional).
- Bellows type sensor for constant and close temperature differential.
- System and fan switches



T513

Model Chart

Model No.	Outputs	Dial	Fan Control	System Switches
T511	Two-pipe	Celsius	3-Speed	On/Off
T511F	Two-pipe	Fahrenheit	3-Speed	On/Off
T513	Four-pipe	Celsius	3-Speed	Heat/Off/Cool
T513F	Four-pipe	Fahrenheit	3-Speed	Heat/Off/Cool

Specifications

Inputs

Power req.	24 to 250 Vac @ 50/60 Hz.
Connections	Power: Up to 18 AWG wire. Control: Up to 18 AWG wire.

Outputs

Electrical	Switch rating (heating): 6 amp resistive, 1.5 amp inductive. Switch rating (cooling): 6 amp resistive, 1 amp inductive. Fan switch rating: 6 amp resistive, 3 amp inductive.
Control ranges	Setpoint adjustment range: 50 to 85 °F (10 to 30 °C). Operating differential: 2 F degrees (1.1 C degrees).
Mechanical	Material: Molded ABS. Finish: Bone white.

Environment

Ambient temperature limits	Shipping and storage: -30 to 130 °F (-34 to 55 °C). Operating: 32 to 130 °F (0 to 55 °C).
Humidity	Non-condensing.
Locations	NEMA Type 1.
Dimensions	5-1/5 H x 3-1/4 W x 1-3/4 D in. (132 x 82 x 45 mm).
Agency Listing	CE compliant.

Accessories

Model No.	Description
WP500	5-1/2 x 5-1/2" (140 x 140 mm) adapter plate.
PIN500	Set point dial stop kit.
CAL500	Set point calibration kit.
680-243	Auto seasonal changeover switch.

On/Off Low/Line Voltage Thermostat/Controller



T500 Series

Typical Applications

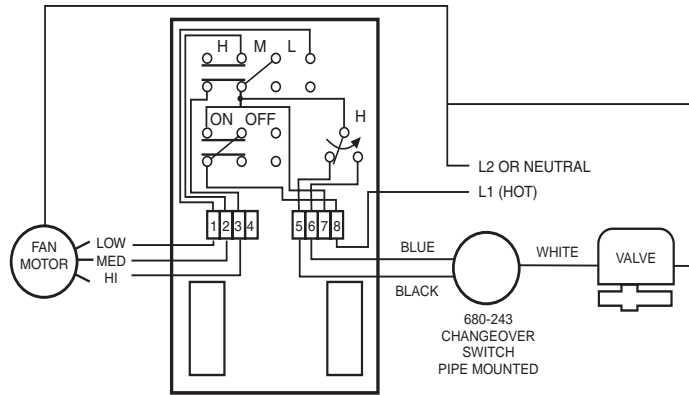

Figure 1 T511, 2-Pipe Heating & Cooling With Changeover Switch.

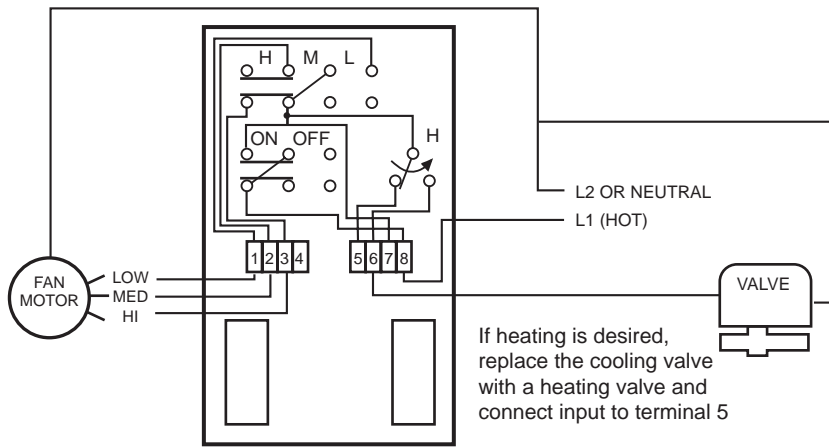

Figure 2 T511/T511F, 2-Pipe Cooling.

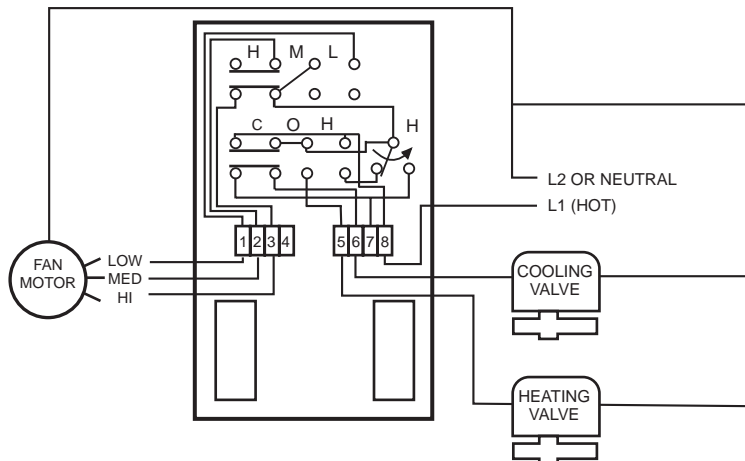

Figure 3 T513/T513F, 4-Pipe Heating/Cooling.

Application

The 31-102 model thermostats control heating and cooling applications which require a single pole/double throw switch, adjustable heat anticipator and fixed cooling anticipator.

The 31-103 model thermostats control heating and cooling applications with adjustable heat anticipator and fixed cooling anticipator. Includes a "Heat-Off-Cool" system switch and "On-Auto" fan switch.

Features

- Mounted directly on wall or standard outlet box with thermometer.
- Adjustable heat anticipator.
- Fahrenheit and Celsius models.
- Dust-proof operation.
- A bi-metal activated mercury bulb is used as the switching mechanism.



31-102



31-103

Model Chart

Model No.	Description	Temperature Range
31-102	Standard low voltage thermostat in Fahrenheit.	50 to 90 °F
31-103	"Heat-Off-Cool" system switch and "On-Auto" fan switch in Fahrenheit.	
31-100	Standard low voltage thermostat in Celsius.	10 to 33 °C
31-101	"Heat-Off-Cool" system switch and "On-Auto" fan switch in Celsius.	

Specifications

Inputs

Power input	24 to 30 Vac, 1.0 amp.
Heat Anticipator	24 Vac, 0.3 to 1.2 amp. Cool anticipator: 5 W

Environment

Ambient temperature limits	Shipping and storage: 0 to 120 °F (18 to 49 °C). Operating: 32 to 110 °F (0 to 43 °C).
Humidity	95% RH, non-condensing.
Locations	NEMA Type 1.
Dimensions	2-3/4 x 4-1/2 inches (70 x 114 mm).

**On/Off Thermostat
31-100 Series**



Typical Applications

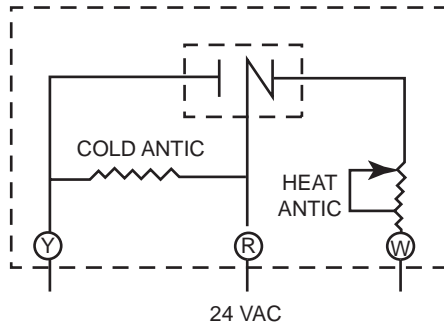

Figure 1 Heat/Cool Thermostats 31-100 and 31-102.

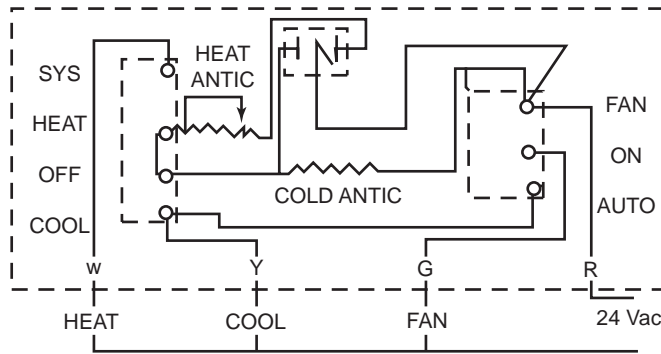

Figure 2 Heat/Cool Thermostat 31-101 and 31-103.

Application

The 680 series low or line voltage changeover switches are designed to switch a thermostat from heating to cooling based on a change in supply water temperature. The 680 series switches can be mounted on 5/8" or 7/8" O.D. copper tube or iron pipe.

Both models are easily mounted to the supply piping with a simple spring clip included with the thermostat. Each thermostat also includes the necessary wire nuts and strain relief bushing.



680-243

Features

- Add-on switch for seasonal change over.
- Includes all necessary parts for installation.
- Snap acting SPDT.

Model Chart

Model No.	Voltage	Inductive		Resistive Amps	Description
		FLA	LRA		
680-243-5	120	5.8	34.8	10	Standard changeover switch
	240	2.9	17.4	5	
680-243-6	120	10.0	60.0	25	Includes a conduit connection
	240	5.0	30.0	25	

Specifications

Inputs

Connections	Color coded leads, 36 in (914 mm).
--------------------	------------------------------------

Outputs

Mechanical	Changeover temperature range: 65 ±5 to 83 ±5 °F (18 ±2 to 28 ±2 °C).
-------------------	--

Environment

Ambient temperature limits	Shipping and storage: -20 to 176 °F (-29 to 80 °C). Operating: 220 °F (104 °C) fluid at ambient temperature of 125 °F (52 °C).
Locations	NEMA Type 1.

Agency Listings

CSA	Approved.
------------	-----------

Typical Application

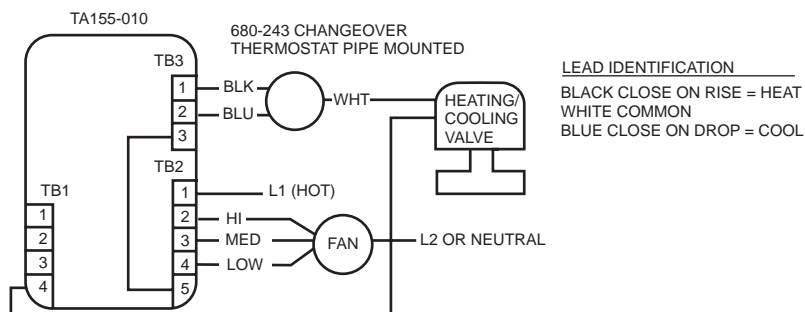



Figure 1 Typical Wiring.

**Seasonal Changeover Switch
680 Series**



Catalog Part Number	Description
---------------------	-------------

PopTop™ Inverted Flare Sweat Fittings
Fits all PopTop 3/4" Inverted Flare and Classic 0647 and 0767 Small Inverted Flare

	436-214-1	1/2" Sweat Female Elbow and Nut
	436-214-4	1/2" Sweat Male Elbow 90° and Nut
	436-220	1/2" Sweat Female Tube and Nut
	436-229-3	1/2" Sweat Male 3" Tube and Nut
	436-252	3/4" Sweat Female Tube and Nut
	436-256	1" Sweat Female Tube and Nut

Replacement Motors for Erie Classic and G Dampers
Class "F" Rated Temperature 250 °F Fluid/169 °F Ambient

	30-118-A	24 Vac 50/60 Hz
	30-118-B	110/120 Vac 50/60 Hz
	30-118-D	208 Vac/60 Hz
	30-118-T	277 Vac, 50/60 Hz
	30-118-U	220/230 Vac 50/60 Hz

Replacement Motors R Classic Valve and Dampers
Class "F" Rated Temperature 250 °F Fluid/169 °F Ambient

	30-140-A	24 Vac 50/60 Hz
	30-140-B	110/120 Vac 50/60 Hz
	30-140-U	220/230 Vac 50/60 Hz

Classic Replacement End Switches
Classic Valves and Dampers

	630-202	Unsealed for Valves and Dampers
	630-232-7	Sealed for 2-Way Valves w/Bearing Plate
	630-232-8	Sealed for 3-Way Valves w/Bearing Plate
	630-274	Sealed for 2 & 3-Way 747 and 773 Valves

Classic Rebuilding Kits (Normally Closed Only)
1/2" & 3/4" Rebuilding Kits for Body Styles 635, 654, 647, 672, 691 and 1" 751

	630-240-1	2 and 3-Way NC, w/o End Switch
	630-240-2	2-Way, NC, w/Sealed End Switch Included
	630-240-3	2 and 3-Way, NC, w/End Switch (Not Included)
	630-240-5	3-Way NC, w/Sealed End Switch Included

Catalog Part Number	Description
---------------------	-------------

Classic Rebuilding Kits (Normally Opened Only - Mfg. after 12/92)
1/2" & 3/4" Rebuilding Kits for Body Styles 635, 654, 647, 672, 691 and 1" 751

	630-259-4	2 and 3-Way NO, w/o End Switch
	630-259-5	2 and 3-Way, NO, w/Sealed End Switch Included
	630-259-6	2 and 3-Way, NO, w/End Switch (Not Included)

Classic Rebuilding Kits (Normally Closed Only)
1" Rebuilding Kits for Body Styles 747, 773

	630-266-1	2 and 3-Way NC, w/o End Switch
	630-266-2	2-Way NC, w/Unsealed End Switch
	630-266-3	3-Way NC, w/Unsealed End Switch

Classic Rebuilding Kits (Normally Opened Only - Mfg. after 12/92) 1" Rebuilding Kits for Body Styles 747, 773

	630-267-3	2 & 3-Way NO, w/o End Switch
	630-267-4	2 & 3-Way, NO, w/End Switch (Not Included)

Classic Modulating Motor Kits for "M", "T", "ST", "P", & "SP", Valves
Actuator Motor and Gear Drive

	645-213	24 Vac for "M" Valves
	646-253	24 Vac for "T" Valves
	646-277	24 Vac for "P" Valves with Circuit Board
	646-279	24 Vac for "SP" Valves with Circuit Board
	646-280	24 Vac for "ST" Valves

Damper Actuator, Accessories
Shaft Kits for Direct Drive "L", "H" & "R" Type

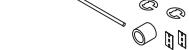
	453-52	6" to 12" Shaft and Hardware, 5/16" Dia.
	453-69	12" to 20" Shaft and Hardware, 5/16" Dia.

Damper Actuator, Replacement Motor (H only)
Class "A" Rated Temperature 120 °F Ambient

	30-145-A	24 Vac 50/60 Hz
	30-145-B	110/120 Vac 50/60 Hz
	30-145-U	220/230 Vac 50/60 Hz

Catalog Part Number	Description
---------------------	-------------

**Boiler Boss® System Accessories
Water Level & Temperature and Outdoor Air Sensors**

	BTS-1 Boiler Temperature Sensor (BB2400)
	LWC-1 Low Water Cutoff w/10' Cable (BB2400)
	OAS-1 Outdoor Air Sensor w/25' Cable (BB1200 and BB2400)
	OAS-2 50' Shielded Cable for OAS-1 (BB1200 and BB2400)
	SENS-10K 10K Enc. Thermometric 3 Sensors – OA, PRI, SEC (BB3000 and BB3600)

**Boiler Boss Accessories
Expansion Relay and Replacement Transformers**

	EXP10 Expansion Relays for SR100 to SR600 Replacement for VL500 and WA300
	EXT10 Foot Mounted, 10 VA, 120 V/24 V
	EXT15 Foot Mounted, 15 VA, 120 V/24 V
	EXT25 Foot Mounted, 25 VA, 120 V/ 24 V
	EXT40 Foot Mounted, 40 VA, 120 V/ 24 V
	EXT75 Foot Mounted, 75 VA, 120 V/ 24 V
	SKT10 Relay Base with Terminals for EXP10

**Boiler Boss Accessories
Fuses – BB3000**

40-8-68	F1 Fuse (5A-250V) Slow Blow
40-8-69	F2 Fuse (10A-250V) Slow Blow

Catalog Part Number	Description
---------------------	-------------

**T 155, 157, 167 & 168 Thermostat Accessories
Sensors, Change-over Switches, Wall Plates**

	65170 Warmer / Cooler Dial/T155/157/167
	65345 4 3/4" x 4 3/4" Cool Gray Wall Plate
	65406 60" Remote Sensor
	65409 Fahrenheit Dial/T155/157/167
	65410 Celsius Dial/T155/157/167
	65860 Dial Stop Kit/T155/157/167
	680-243-5 36" Changeover Switch
	680-243-6 36" c/o Switch with Conduit Connection

**Room Thermostats Accessories
Transformers, 120 Vac to 24 Vac, 240 Vac to 24 Vac**

28-240	Hub Mount, 20 VA, 240 V to 24 Vac
28-260	Plate Mounted, 40 VA, 120 V/24 V

Actuator Specification

Water hammer is symptomatic of a system problem, such as high differential pressure across a valve, a 2-way valve installed backward, or a pump dead heading against a valve attempting to close off. Variable high differential pressures can damage zone valve actuators. Differential pressure across a valve is not the same as pump head pressure, or static pressure in a system.

Differential pressure across a valve in a closed loop system affects the close-off capability of the actuator. It is the difference in pressure between pump supply and pump return. Do not exceed the valve Differential Pressure close-off ratings published in the **Erie installation valve data sheets and the Valve Selection pages in this publication.**

Subject to inspection, actuators with gears damaged by water hammer due to differential pressure excess, are not covered by Invensys warranty.

Relationship to Specification

The smaller a valve's port, the greater the actuator's ability to close without noise or seat leakage. From Invensys data, select the actuator's pressure differential specification while maintaining adequate (Cv) flow to the load.

System solutions to valve noise from pump head pressures include: a pressure differential regulator by-pass across a pump's supply and return (loop) to eliminate pump head pressure spikes, selection of a pump with a flatter curve, and boiler Indoor/Outdoor reset control.

For valve seat by-pass leakage (inability to stop flow), use a lower Cv valve or a High close-off actuator. Cv means Capacity value (or Gallons Per Minute at a one lb. pressure drop across the valve). For most standard heating replacement applications, a 3.5 Cv valve will work with a General rated actuator. However, if you need to estimate a Cv: divide the GPM by the Square Root of the acceptable pressure drop.

$$Cv \text{ req'd} = \frac{\text{Estimate GPM req'd}}{\sqrt{\text{estimate allowable pressure drop across valve}}}$$

Example: One US gallon (4 L) heated from 160 °F to 180 °F will release 10,000 BTUs of heat. Therefore, a 3.5 Cv valve is capable of transferring 35,000 BTUs at a 1 lb drop across its port to the load (coil, baseboard, etc.).

Oxygenated (potable) Water

Erie zone valves are designed for use in closed loop heating and cooling systems only. They are not meant to operate in systems where fresh (oxygenated) water is used for human or animal consumption. For pool or spa, space heating and cooling, where oxygenated water is used as the media, the zone valve must be placed on the closed loop side of a heat exchanger. Subject to inspection, zone valves exhibiting premature failure from corrosion due to oxidation from excess fresh oxygen, or improperly treated boiler water will not be covered by Invensys warranty.

Thermostats and Transformers

Troubleshooting a system by shorting across thermostat load connections will burn out heat anticipators in mechanical thermostats, and will destroy Triacs in electronic thermostats. Subject to inspection, thermostats with evidence of electrical short will not be covered by Invensys warranty.

Short circuiting a transformer secondary will burn out the transformer primary. Subject to inspection, transformers with evidence of electrical short, will not be covered by Invensys warranty.

All specifications are nominal and may change as design improvements are introduced. Invensys Building Systems shall not be liable for damages resulting from misapplication or misuse of its products.

Invensys, Boiler Boss, Erie, PopTop, and Priority Plus are trademarks of Invensys plc and its subsidiaries and affiliates. All other trademarks are the property of their respective owners.

The confidential information contained in this document is provided solely for use by Invensys employees, licensees, and system owners, and is not to be released to, or reproduced for, anyone else. Neither is it to be used for reproduction of this control system or any of its components.

© Copyright 2003 Invensys plc. All rights reserved.

No part of this document may be photocopied or reproduced by any means, or translated to another language without prior written consent of Invensys.