

MA51-710x Two Position Series MF51-7103 Floating Series MS51-7103 Proportional Series

DuraDrive™ Linear Series Spring Return Actuator General Instructions

Application

DuraDrive Linear Actuators are designed to mount directly onto two-way or three-way globe valves without the use of linkages. They provide linear travel to operate valves from 1/2" to 2" VB-7xxx and discontinued 1/2" to 1-1/4" VB-9xxx in chilled water, hot water and steam applications up to 366 °F (186 °C). Linear spring return actuators provide either two position, floating or proportional modulation control (depending on model selection) of valves in HVAC systems.

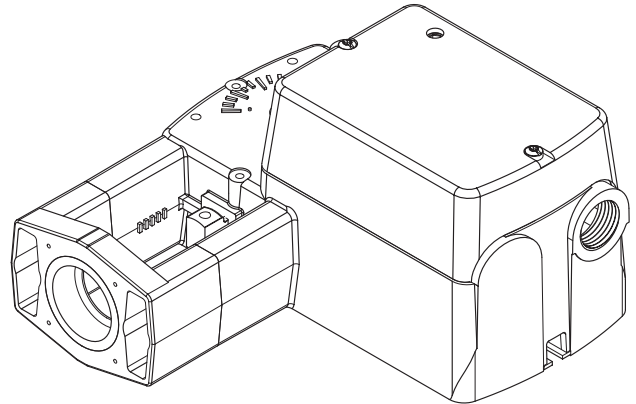

Mx51-710x



Features

- Two position models controlled by SPST controller
- Floating models controlled by SPDT floating controllers
- Proportional models controlled by 0-3 Vdc, 6-9 Vdc, 0-10 Vdc, 0-20 mAdc, 2-10 Vdc, or 4-20 mAdc. Control function direct/reverse action is jumper selectable
- 105 lb force (467 newton) with 1/2" (13 mm) nominal linear stroke
- 24 Vac, 120 Vac, and 230 Vac models
- Rugged polymer housings rated for up to NEMA 2/IP54
- Overload protection throughout stroke
- Automatically sets input span to match valve travel
- Compact size to allow installation in limited space
- Manual override to allow positioning of valve and preload
- Spring return operation
- Direct mount to valves without separate linkage
- Polymer housing rated for plenum use
- Five year warranty

Applicable Literature

F-Number	Description	Audience	Purpose
F-26080	EN-205 Water System Guidelines	<ul style="list-style-type: none"> - Application Engineers - Installers - Service Personnel - Start-up Technicians 	Describes Invensys Building Systems approved water treatment practices.
F-27252	VX-7XXX-8XX Series VX-7XXX-59X Series VX-9XXX-8XX Series VX-9XXX-59X Series Selection Guide	<ul style="list-style-type: none"> - Sales Personnel - Application Engineers - Installers - Service Personnel - Start-up Technicians 	Provides Mxx1-720x and Mx51-710x actuator, valve, and valve assembly selection data including specifications, close-off pressures, and dimensional information.
F-26895	AM-703 Input Scaling Module, AM-704 Pulse Width Modulation Interface, AM-705 Positioner, AM-706 Positioner, AM-708 Resistor	<ul style="list-style-type: none"> - Installers - Service Personnel - Start-up Technicians 	Provides step-by-step mounting instructions
F-27175	AM-756 Metric Conduit Adapter, AM-763 Hexcrank, AM-770 Replacement Valve Linkage Parts Kit	<ul style="list-style-type: none"> - Installers - Service Personnel - Start-up Technicians 	Provides step-by-step mounting instructions

SPECIFICATIONS

Actuator Inputs

Control Signal: See Table-1 for actuator models and control type.

Power Input: See Table-1. All 24 Vac circuits are Class 2. All circuits 30 VAC and above are Class 1.

Connections: 3 ft (91 cm) appliance wire or plenum cables, enclosure accepts 1/2" (13 mm) conduit connectors. For M20 Metric connector, use AM-756 adaptor.

Actuator Outputs

Electrical:

Position Feedback Voltage (proportional or floating only),

For voltage ranges, the feedback signal is the same range as the input signal. The 4-20 mA_{dc} current range and floating actuators have a 2-10 V_{dc} position feedback signal. The position feedback signal can supply up to 0.5 mA_{dc} to operate up to four additional slave actuators.

Mechanical:

Linear Stroke, 1/2" (13 mm) nominal.

Approx. Stroke Timing, See Table-1.

Manual Override, Allows positioning of valve and preload using manual crank.

Right/Left Jumper, Permits reverse acting/direct acting linear motion (MS51 only).

Environment:

Ambient Temperature Limits,

Shipping & Storage, -40 to 160 °F (-40 to 71 °C).

Operating, -22 to 140 °F (-30 to 60 °C).

Temperature Restrictions, For maximum ambient 140 °F (60 °C) the maximum allowable fluid temperature should not exceed valve rating. See F-27252 Selection Guide for specific ratings.

Humidity: 5 to 95% RH, non-condensing.

Location:

NEMA 1. NEMA 2 (enclosure is air plenum rated), UL Type 2 (IEC IP54) with customer supplied water tight conduit connectors.

Agency Listings

UL 873: Underwriters Laboratories (File #E9429 Category Temperature-Indicating and Regulating Equipment).

CUL: UL Listed for use in Canada by Underwriters Laboratories. Canadian Standards C22.2 No. 24-93.

European Community: EMC Directive (89/336/EEC). Low Voltage Directive (72/23/EEC).

Australia: This product meets requirements to bear the C-Tick Mark according to the terms specified by the Communications Authority under the Radio Communications Act 1992.

Note: All performance specifications are nominal and conform to acceptable industry standards. For applications at conditions beyond these specifications, consult Invensys Building Systems. Invensys shall not be liable for damages resulting from misapplication or misuse of its products.

Table-1 Specifications.

Part Number	Control Signal	Actuator Power Input						Approximate Stroke Timing in Seconds @ 70F (21°C) ^a	
		Voltage	Wiring System	Running		DC Amps	Holding	Powered	Spring Return
				50/60 Hz	50/60 Hz				
			VA	W					
MA51-7103-000	Two Position SPST	24Vac ±20% 20-30 Vdc	Appliance Wire	5.3	4.1	0.15	1.2	44	19
MA51-7103-100			Plenum Cable	5.3	4.1	0.15	1.2		
MA51-7100-000		120 Vac ±10% 50/60 Hz	Appliance Wire	7.9	6.2	n/a	2.1		
MA51-7101-000		230 Vac ±10% 50/60 Hz	Appliance Wire	7.4	5.4	n/a	2.1		
MF51-7103-000	Floating	24Vac ±20% 20-30 Vdc	Appliance Wire	6.9	4.7	0.16	2.1	60	16
MF51-7103-100			Plenum Cable	6.9	4.7	0.16	2.1		
MS51-7103-000 ^b	2-10 Vdc Proportional ^c		Appliance Wire	6.6	4.2	0.14	1.5		
MS51-7103-100 ^b			Plenum Cable	6.6	4.2	0.14	1.5		
MS51-7103-020 ^b	0-3 Vdc Proportional		Appliance Wire	6.6	4.2	0.14	1.5		
MS51-7103-120 ^b			Plenum Cable	6.6	4.2	0.14	1.5		
MS51-7103-030 ^b	6-9 Vdc Proportional		Appliance Wire	6.6	4.2	0.14	1.5		
MS51-7103-130 ^b			Plenum Cable	6.6	4.2	0.14	1.5		
MS51-7103-040 ^{b d}			Appliance Wire	7.8	4.9	0.16	3.4		
MS51-7103-140 ^{b d}			Plenum Cable	7.8	4.9	0.16	3.4		
MS51-7103-050 ^b	0-10 Vdc Proportional		Appliance Wire	6.6	4.2	0.14	1.5		
MS51-7103-150 ^b			Plenum Cable	6.6	4.2	0.14	1.5		
MS51-7103-060 ^b	4-20 mA ^d	Appliance Wire	6.6	4.2	0.14	1.5			
MS51-7103-160 ^b		Plenum Cable	6.6	4.2	0.14	1.5			

- ^a Timing was measured with the actuator mounted on a VB-7xxx Series valve.
- ^b Proportional (MS) models shipped with RA/DA jumper set for DA (actuator extends with increasing signal).
- ^c 4-20 mA^d with AM-708 500 ohm field-installed resistor.
- ^d Has 20 Vdc power supply for System 8000 applications.

Globe Valve Close-Off Pressures: For close-off pressure ratings on globe valve assemblies, consult Linked Globe Valve Assemblies with DuraDrive Linear Series Actuators Selection Guide F-27252.

ACCESSORIES

- AM-756 Metric Conduit Adapter M20 x 1.5 to 1/2" NPT
- AM-770 Replacement valve linkage parts kit
- AM-764 Linkage kit for damper applications

MS51-7103

- AM-703 Input rescaling module, adjust signals to 2-10 Vac, zero and span adjust
- AM-704 Interface, pulse width modulation (PWM)
- AM-705 Positioner (NEMA 4 housing)
- AM-706 Min and/or manual positioner for flush panel mount
- AM-708 500 ohm resistor for 4 to 20 mA control signal

TYPICAL TWO POSITION CONTROL (wiring diagrams)

Figure-1 illustrates typical wiring diagrams for spring return **two-position MA51-710x** actuators. See Table-1 for model selection. See 8 for wiring diagrams notes guide.

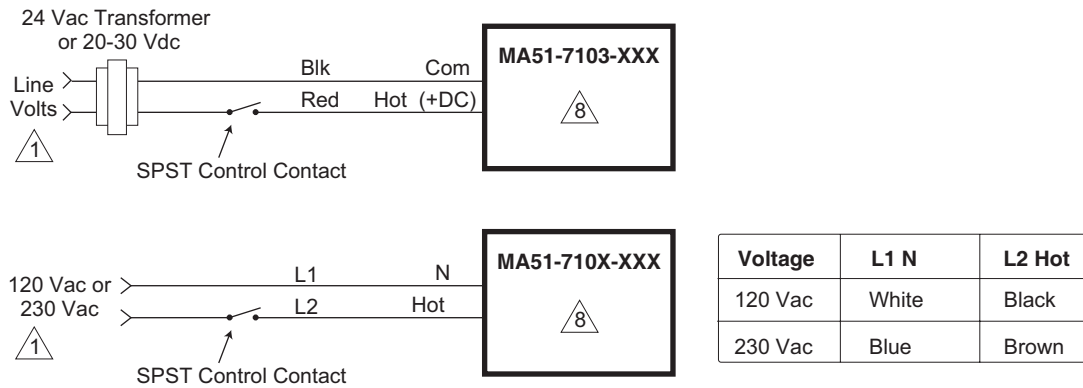

Figure-1 Typical Wiring Diagrams for Two Position Actuators

TYPICAL FLOATING CONTROL (wiring diagrams)

Figure-2 through Figure-5 illustrates typical wiring diagrams for spring return **floating MF51-7103** actuators. See Table-1 for model selection. See 8 for wiring diagrams notes guide.

Caution: This product contains a half-wave rectifier power supply and must not be powered off transformers used to power other devices utilizing non-isolated full-wave rectifier power supplies. Refer to *EN-206, Guidelines for Power Multiple Devices from a Common Transformer, F-26363* for detailed information.

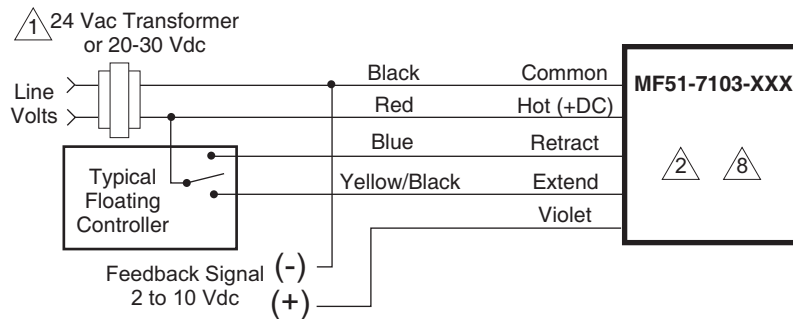

Figure-2 Floating Point Control

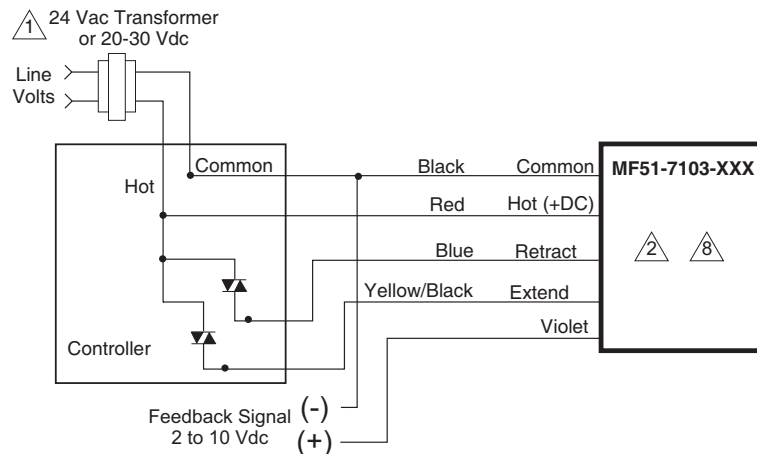

Figure-3 Triac Source

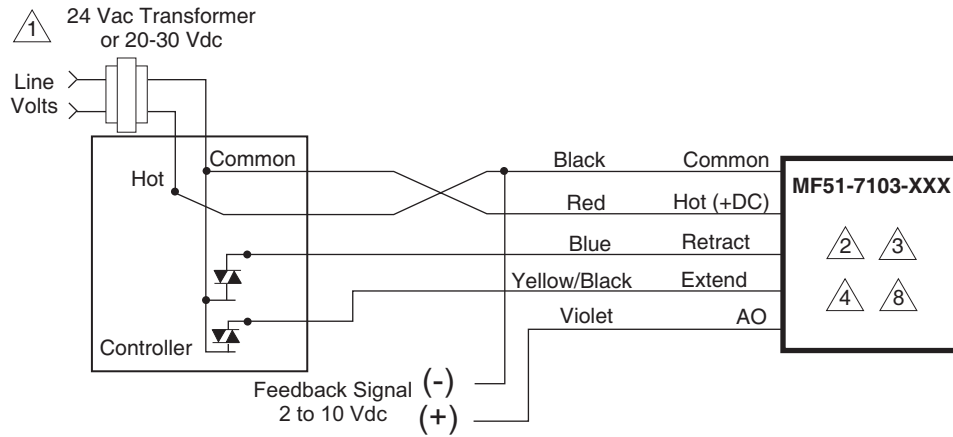

Figure-4 Triac Sink

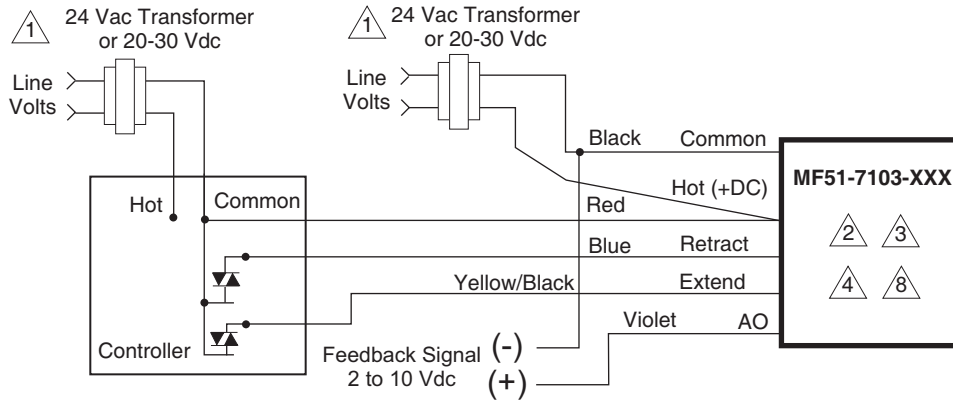

Figure-5 Triac Sink With Separate Transformers

TYPICAL PROPORTIONAL CONTROL (wiring diagrams)

Figure-6 illustrates typical wiring diagrams for spring return **proportional MS51-7103** actuators. See Table-1 for model selection. See 8 for wiring diagrams notes guide.

Caution: This product contains a half-wave rectifier power supply and must not be powered off transformers used to power other devices utilizing non-isolated full-wave rectifier power supplies. Refer to *EN-206, Guidelines for Powering Multiple Devices from a Common Transformer, F-26363* for detailed information.

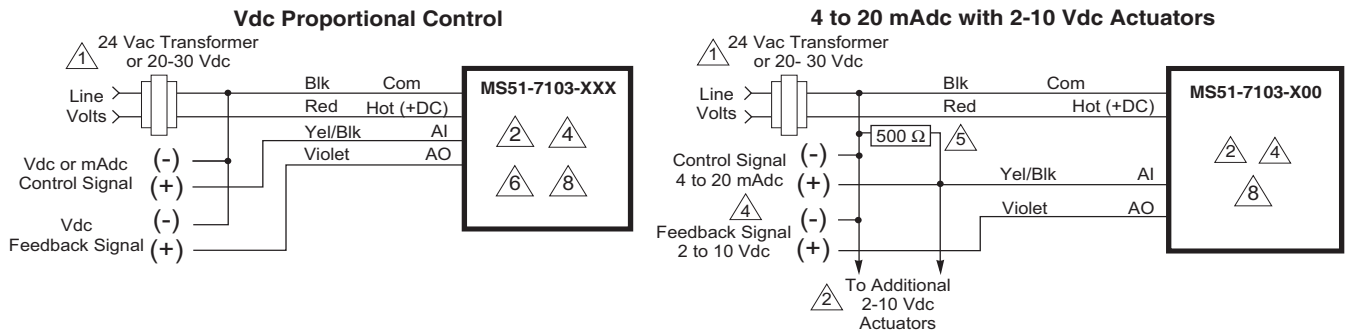

Figure-6 Typical Wiring Diagrams for Proportional Control 24 Vac Basic Models

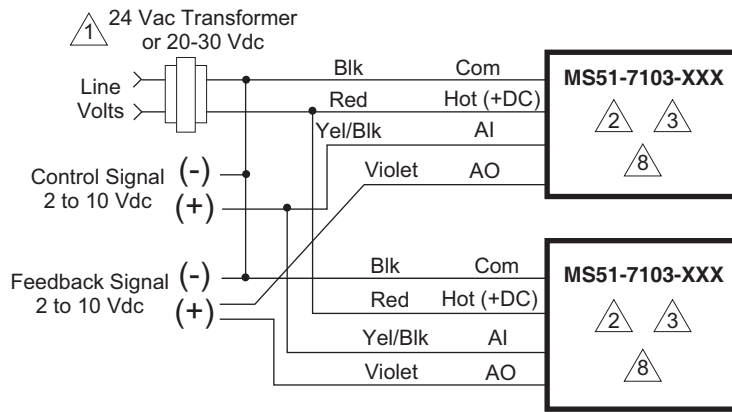

Figure-7a Typical Wiring Diagrams for Proportional Control 24 Vac Models Wired in Parallel

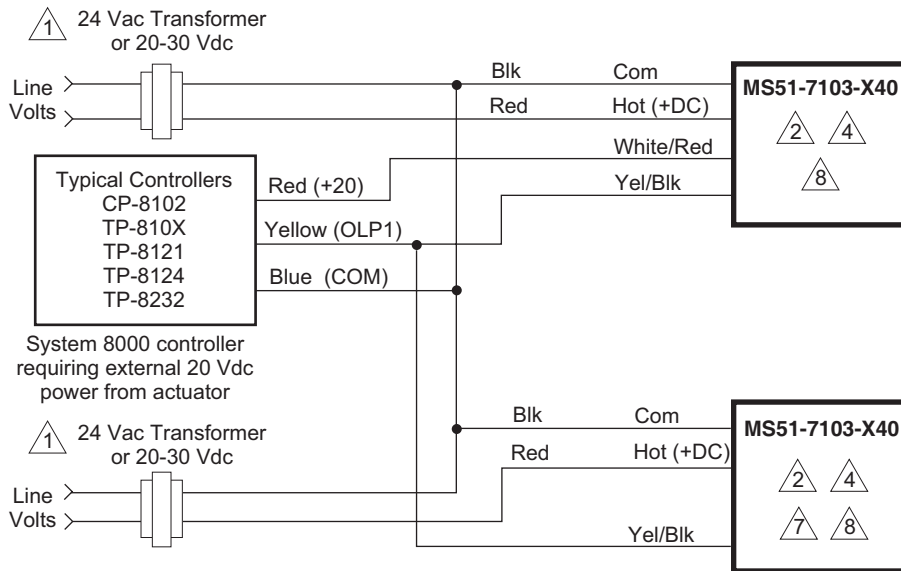

Figure-7b Typical Control Wiring for Two MS51-7103-X40 to System 8000 Controllers Requiring External 20 Vdc Power from Actuator

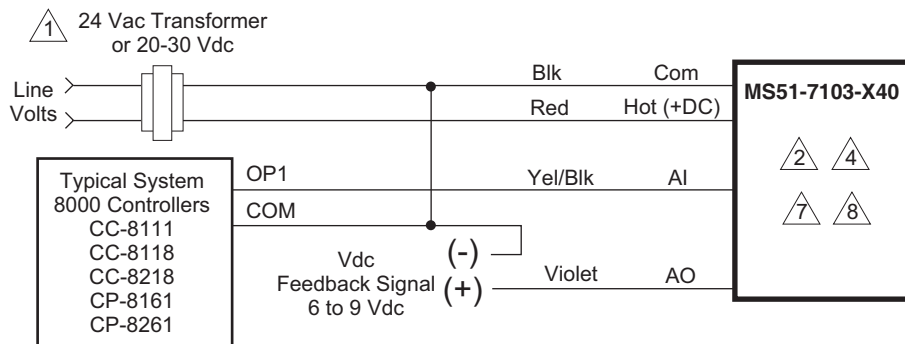

Figure-7c Typical Control Wiring for MS51-7103-X40 to Controllers not Requiring External 20 Vdc Power from Actuator

- 1 Provide overload protection and disconnect as required.
- 2 Actuators may be wired (120V mA does not have red wire and 230V mA does not have red or black wires) in parallel. All actuator black wires are connected to the transformer common and all red wires are connected to the hot lead. Power consumption must be observed.
- 3 The Common connection from the actuator must be connected to the Hot connection of the controller. The actuator Hot must be connected to the controller Common.
- 4 If the controller uses a full-wave power supply and does not provide isolated outputs, a separate transformer is required.
- 5 A field-supplied 500 ohm resistor (AM-708) is required for this application.
- 6 On MS51-7103-X60 (4-20 mA) models a 500 ohm resistor is incorporated in the product. Do not use an external resistor.
- 7 If using multiple MS51-7103-040's with System 8000 controller requiring 20 Vdc power; tape off red +20 Vdc power supply leads on all but one actuator.
- 8 Cable on some models contains more wires than are used in applications. Only those wires actually used are shown.

Figure-8 Wire Diagram Notes Guide

INSTALLATION

Inspection

Inspect the package for damage. If damaged, notify the appropriate carrier immediately. If undamaged, open the package and inspect the device for obvious damage. Return damaged products.

Requirements

- Job wiring diagrams
- Appropriate accessories
- Pliers for removing and inserting connecting pin
- Installer must be a qualified, experienced technician
- TOOL-37, 1 5/8" open end wrench for valve mounting nut
- 5/16" and 7/16" open-end wrench for stem jam nuts and stem extension
- #8 Torx screwdriver (not provided)

Precautions



General

Warning:

- Electrical shock hazard! Disconnect the power supply (line power) before installation to prevent electric shock and equipment damage.
- Make all connections in accordance with the job wiring diagram and in accordance with national and local electrical codes. *Use copper conductors only.*
- Floating and Proportional Models: These products contain a half-wave rectifier power supply. They must not be powered with transformers that are used to power other devices utilizing non-isolated full-wave rectifier power supplies. Refer to EN-206, Guidelines For Powering Devices From A Common Transformer, F-26363 for detailed information.

Caution:

- Avoid electrical noise interference. Do not install near large contactors, electrical machinery, or welding equipment.
- Manual override to be used only when power is not applied to unit.
- When operating manual override (observe position indicator), back off 5° from full extended mechanical stop to ensure proper release.
- Use with fluid temperatures above 100°C requires insulation on the pipe and control valve.

Federal Communications Commission (FCC)

Note: This equipment has been tested and found to comply with the limits for a Class B digital device, pursuant to Part 15 of the FCC Rules. These limits are designed to provide reasonable protection against harmful interference in residential installations. This equipment generates, uses, and can radiate radio frequency energy and may cause

harmful interference if not installed and used in accordance with the instructions. Even when instructions are followed, there is no guarantee that interference will not occur in a particular setting—Which can be determined by turning the equipment off and on—the user is encouraged to try to correct the interference by one or more of the following measures:

- Reorient or relocate the receiving antenna.
 - Increase the separation between the equipment and receiver.
 - Connect the equipment to an outlet on a circuit different from that to which the receiver is connected.
 - Consult the dealer or an experienced radio/television technician for help.
-

Canadian Department of Communications (DOC)

Note: This Class B digital apparatus meets all requirements of the Canadian Interference-Causing Equipment Regulations.

Cet appareil numérique de la classe B respecte toutes les exigences du Règlement sur le matériel brouilleur du Canada.

European Standard EN 55022

Warning: This is a Class B digital (European Classification) product. In a domestic environment this product may cause radio interference in which case the user may be required to take adequate measures.

Location

Caution: Avoid locations where excessive moisture, corrosive fumes, vibration, or explosive vapors are present.

Mounting

- Mount the linear actuator directly on the valve in locations that clear the maximum dimensions of the actuator case (see Figure-12).
- Ensure that the valve body is installed correctly. The arrow must point in the direction of flow. With three-way valves observe stem position (stem up or stem down) for proper flow characteristics. See Table 3.
- It is preferable that the actuator is mounted above the valve body. This will minimize the risk of damage to the actuator in the event of condensation or a valve leak. Refer to Figure-10.

Changing Control Function (proportional units only)

These actuators are equipped with a jumper to control the function of the signal as received. See Figure-9. Factory setting is for direct acting. Remove cover to change jumper setting.

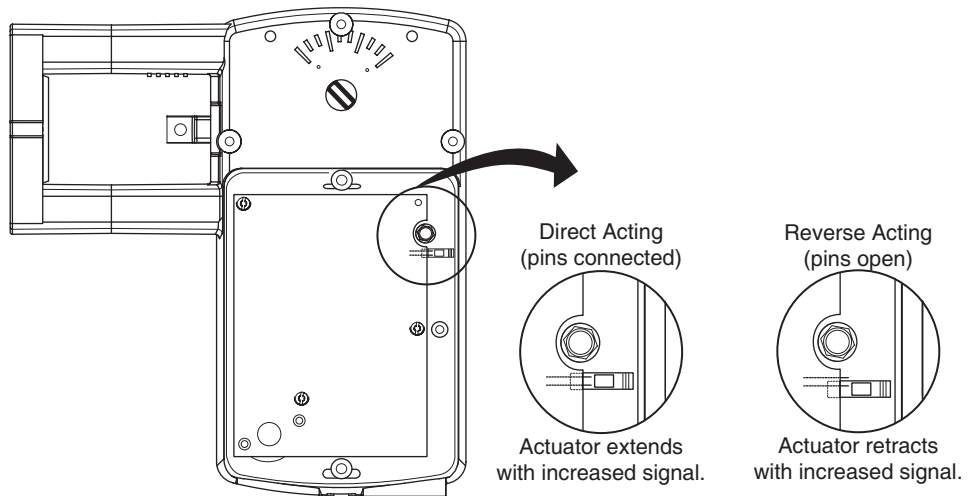

Figure-9 RA/DA Jumper Setting for Proportional Models

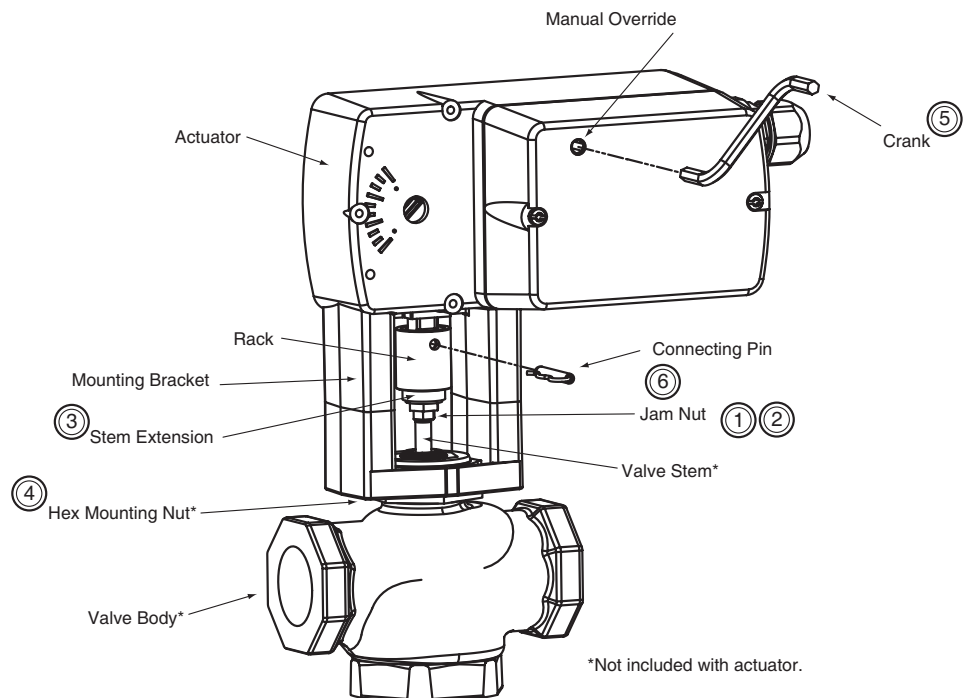

Figure-10 Mx51-710x Series Actuator Exploded View

Installation: Mx51-710x Series Actuator to 1/2" to 2" VB-7xxx Series Valve Bodies, 2-Way Stem-Up Closed and 3-Way Mixing or Diverting Applications

- A. Preload the valve to insure proper close-off according to the numbered steps in Figure-10 and the text below. (Remove power before proceeding.)
1. Locate the steel jam nut that came packaged with the actuator. (Do not re-use the brass jam nut present on an existing valve.)
 2. Screw the nut onto the valve stem all the way as far as it will go (you may need to use a TOOL-20-1 or a 5/16" open-end wrench). At least 1/2" of the valve stem should extend above the nut.
 3. Thread the stem extension onto the valve stem, making contact with the jam nut. Raise the valve stem to the full up position.

4. Orient the actuator mounting bracket on the valve and tighten the hex mounting nut securely against the bracket using TOOL-37.
 5. Insert the crank provided in the actuator cover. Wind the crank two turns counterclockwise. Press in the turn crank 1/8 turn counterclockwise to lock in position.
 6. Rotate the stem extension until the through holes in the stem extension and rack line up. Insert connecting pin to secure stem extension and tighten jam nut against stem extension using TOOL-20-1 or a 5/16" open end wrench.
- B. Apply power to the actuator and check the system operation for heating or cooling output in response to the control signal.

Installation: Mx51-710x Series Actuator to 1/2" to 2" VB-7xxx Series Valve Bodies, 2-Way Stem-Up Open

- A. Preload the valve to insure proper close-off according to the numbered steps to 10 and the text below. (Remove power before proceeding.)
1. Locate the steel jam nut that came packaged with the actuator. (Do not re-use the brass jam nut present on an existing valve.)
 2. Screw the nut onto the valve stem all the way as far as it will go (you may need to use a TOOL-20-1 or a 5/16" open-end wrench). At least 1/2" of the valve stem should extend above the nut.
 3. Thread the stem extension onto the valve stem, making contact with the jam nut. Push the valve stem to the full down position.
 4. Orient the actuator mounting bracket on the valve and tighten the hex mounting nut securely against the bracket using TOOL-37.
 5. Insert the crank provided in the actuator cover. Wind the crank counterclockwise until the actuator fully extends, then unwind 2 turns and press in and turn crank 1/8 turn counterclockwise to lock in position.
 6. Rotate the stem extension until the through holes in the stem extension and rack lineup. Insert connecting pin to secure stem extension and tighten jam nut against stem extension using TOOL-20-1 or a 5/16" open end wrench.
- B. Apply power to the actuator and check the system operation for heating or cooling output in response to the control signal.

Valve Mounting

The valve should be mounted in a weather-protected area, in a location that is within the ambient temperature limits of the actuator. The installation of the actuator assembly should provide clearance on all sides to allow for any maintenance that may be needed (see Figure-10 and Figure-11).

1. Following general piping practices is recommended.
2. Apply pipe sealant sparingly to all but the last two threads of a properly threaded, reamed, and cleaned pipe. Make sure the pipe chips, scale, etc. do not get into the pipe since this material may lodge in the valve seat and prevent proper closing and opening of the valve. The valve must be piped with an inlet and an outlet.
3. Start the joint hand-threading the pipe into the valve. If the thread alignment feels normal, continue to turn the pipe by hand as far as it will go.
4. Use a pipe wrench to fully tighten the pipe to the valve.

Caution: Do not over-tighten the pipe, which may cause stripped threads. Avoid twisting or crushing the valve while tightening the pipe.

5. Insulate only the valve body and associated piping, not the actuator.
6. In chilled or cold water systems where the environment is humid, use a drip pan under the valve to catch condensate.

Caution: The DuraDrive linear actuator is designed to effectively support its own weight. No load or weight should be resting on the actuator, long term damage may occur to the actuator, mounting connection or the valve.

- Do not insulate the actuator/linkage. Doing so will result in excess heat buildup within the actuator.

- For non-steam application the globe valve assembly must be mounted so that the actuator is at least 5° above the horizontal (Figure-11) to ensure that any condensate that forms will not travel into the mounting bracket or actuator.
- On steam applications, the globe valve assembly must be mounted approximately 45° from horizontal.
- Temperature Restrictions: For maximum ambient 140 °F (60 °C) the maximum allowable fluid temperature should not exceed valve rating. See F-27252 Selection Guide for specific ratings.

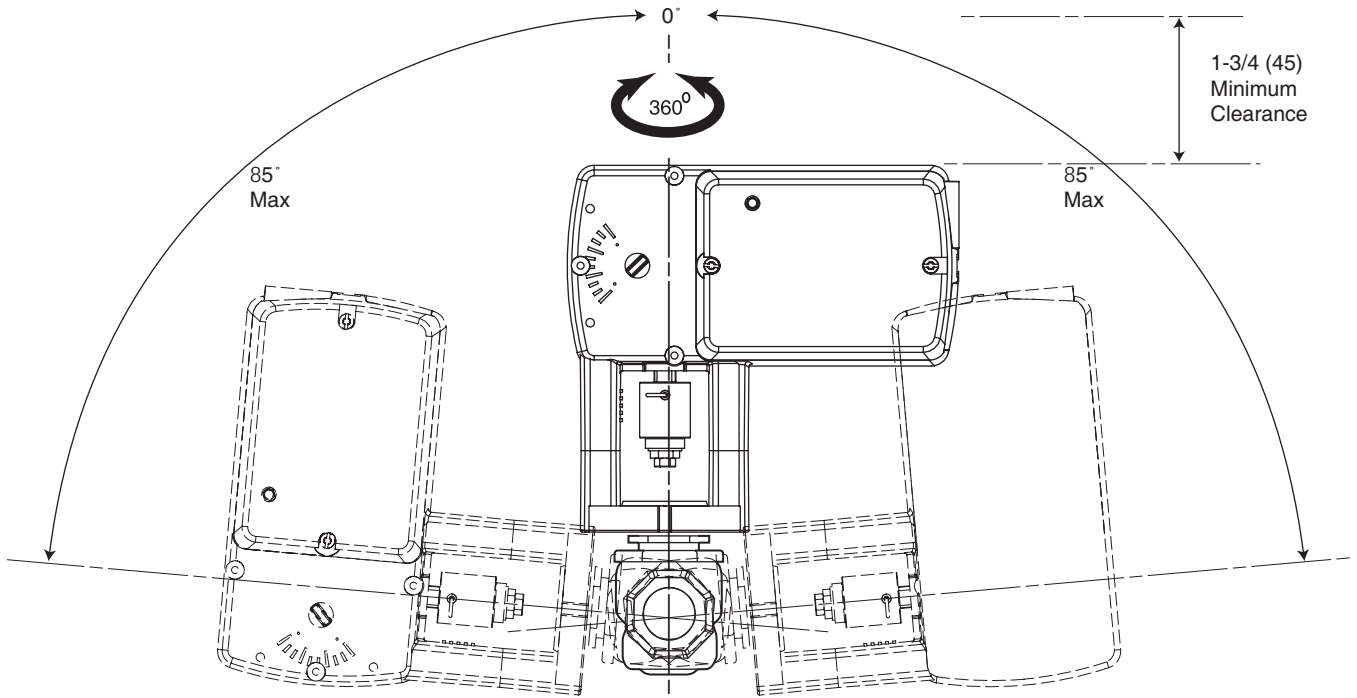

Figure-11 Acceptable Mounting Orientations for Non-Steam Applications

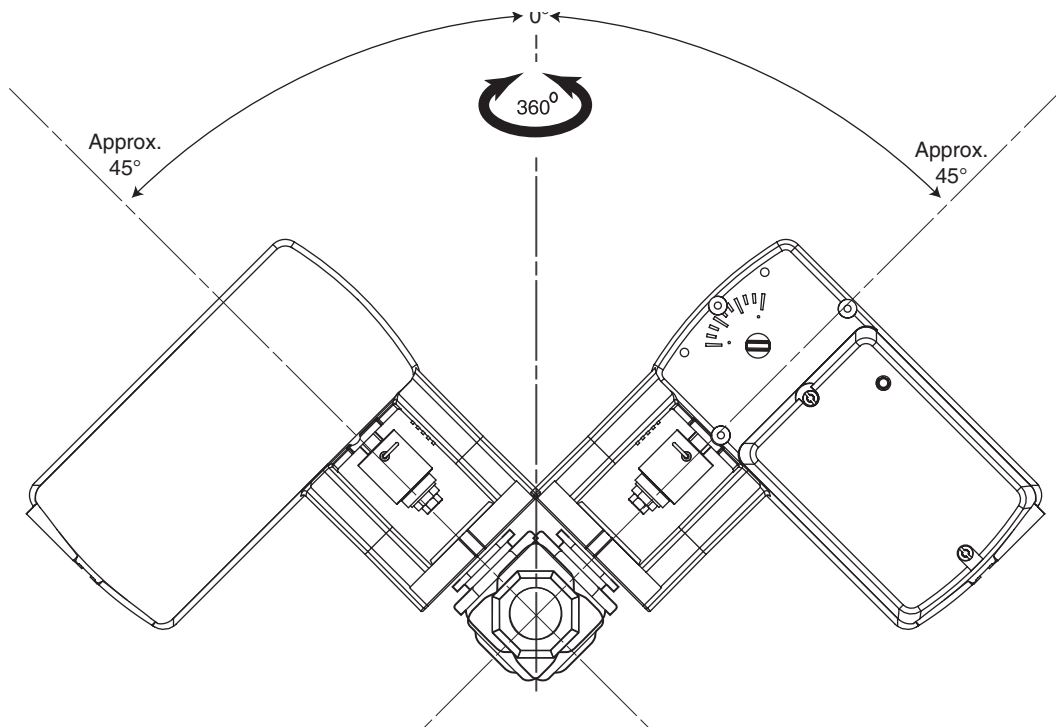

Figure-12 Acceptable Mounting Orientation for Steam Applications

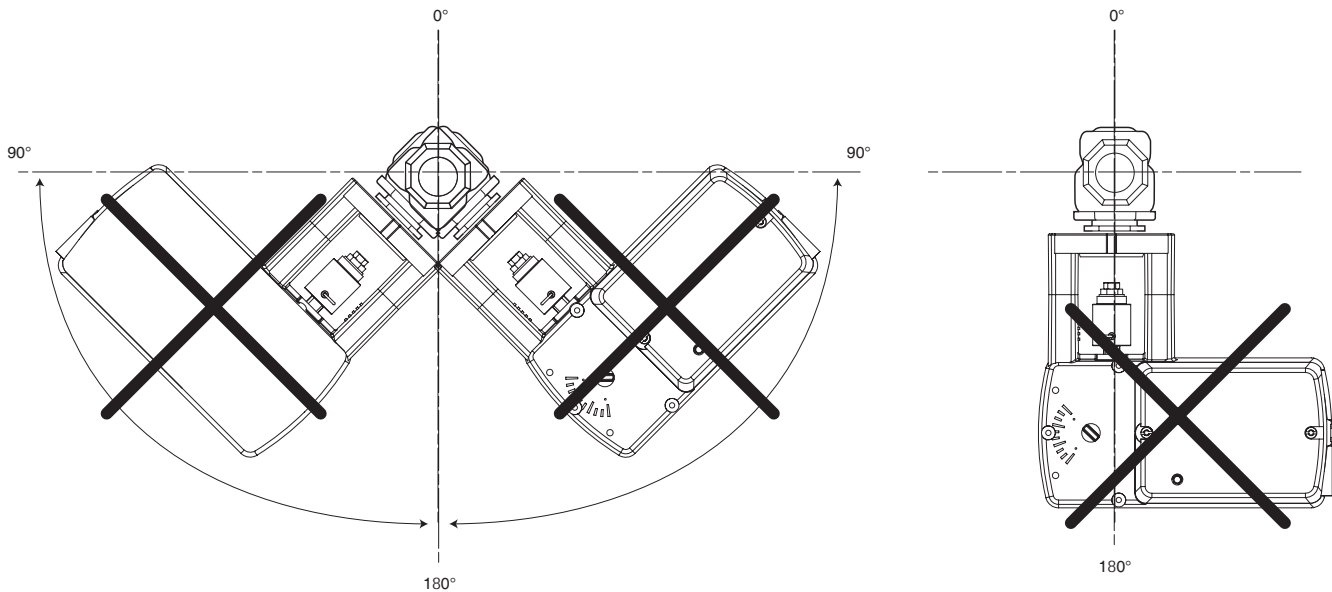

Figure-13 Unacceptable Mounting Orientation

MANUAL OVERRIDE OPERATION

When necessary, the actuator's output shaft can be repositioned using the manual override mechanism as follows:

1. Disconnect power from the actuator. The actuator will fully retract.
2. Without pushing down on the crank, crank the manual override counterclockwise until the actuator extends to the desired position. Push in until the mechanism locks in position. (The manual override lock will release the next time power is applied.)
3. If you desire to reposition the actuator manually from a locked position, turn the crank 1/8 turn counterclockwise and pull out to release. Adjust position as desired.

Caution:

- Only use manual override when the actuator drive motor is not powered.
 - Engaging the manual override when the actuator is powered may cause damage to the gears.
 - Using power tools to adjust the override will cause damage to the gears.
-

Wiring Requirements

Control Leads

See Table-2 for power wiring data. Refer to Figure-1 through Figure-7 for typical wiring.

Table-2 Power Wiring

Actuator Voltage	Part Number	Maximum Wire Run in ft. (m)					
		12 AWG	14 AWG	16 AWG	18 AWG	20 AWG	22 AWG
24 Vac 20-30 Vdc	MA51-7103	1678 (512)	1055 (322)	664 (202)	417 (127)	263 (80)	208 (63)
	MF51-7103	1289 (393)	810 (247)	510 (155)	321 (98)	202 (61)	160 (49)
	MS51-7103	1140 (348)	717 (219)	451 (137)	284 (86)	178 (54)	141 (43)

CHECKOUT

After the entire system has been installed and the actuator has been powered up, the following check can be made for proper system operation. Check for correct operation of the valve while actuator is being stroked.

1. Apply power to the actuator. Actuator and valve should be driven to their powered position

as determined by the control signal. Refer to Table-3 for valve flow.

2. Break power to the actuator. Actuator and valve should return to the spring return position (retracted position).

Table-3 Assembly Configuration Chart

Valve Body	Valve Body Action	Normal Position		Action ^a
		Valve Stem	Flow	
VB-721x VB-921x ^b	Two-Way Stem Up Open	Up	Open	A to AB flow decreases as actuator extends
VB-722x VB-922x ^b	Two-Way Stem Up Closed	Up	Closed	A to AB flow increases as actuator extends
VB-731x VB-931x ^b	Three-Way Mixing	Up	B to AB	A to AB flow increases as actuator extends B to AB flow decreases as actuator extends
VB-732x VB-932x ^b	Three-Way Diverting	Up	B to AB	B to A flow increases as actuator extends B to AB flow decreases as actuator extends

^a Proportional models shipped with RA/DA jumper set for DA (actuator extends with increasing signal).

^b Discontinued 1/2" to 1-1/4" VB-9xxx.

Note: Check that the transformer(s) are sized properly.

- If a common transformer is used with multiple actuators, make sure that polarity is observed on the secondary. This means connecting all black wires to one leg of the transformer and all red wires to the other leg of the transformer.
 - If multiple transformers are used with one control signal, make sure all black wires are tied together and tied to control signal negative (-).
 - If the controller uses a full-wave power supply and does not provide isolated outputs, a separate transformer is required.
-

THEORY OF OPERATION

The MA, MF and MS series actuators are directly mounted onto the valve without the use of a separate linkage. They are equipped with true mechanical spring return operation for reliable, positive close-off on valves. When power is applied, the actuator moves to its powered position, at the same time tensing the spring return safety mechanism. When the power is removed, the spring returns the actuator to its normal position (retracted position). The spring return system provides consistent close-off force to the valve.

MA series two-position actuators use a DC motor controlled by on board electronics. When the actuator encounters a stall or end of travel position, the motor current is automatically reduced, preventing damage to the actuator or motor.

MF or MS series floating or proportional actuators use a DC motor which is controlled by a microprocessor. The microprocessor supplies the intelligence to provide a constant speed and to know the actuator's exact position. The microprocessor monitors and controls the DC motor's rotation and provides a digital rotation sensing function to prevent damage to the actuator in a stall condition.

All actuators may be stalled anywhere in their normal rotation without the need of a mechanical end switch.

MAINTENANCE

Regular maintenance of the total system is recommended to assure sustained optimum performance. The Linear series actuators are maintenance free.

FIELD REPAIR

None. Replace with a functional actuator.

DIMENSIONAL DATA

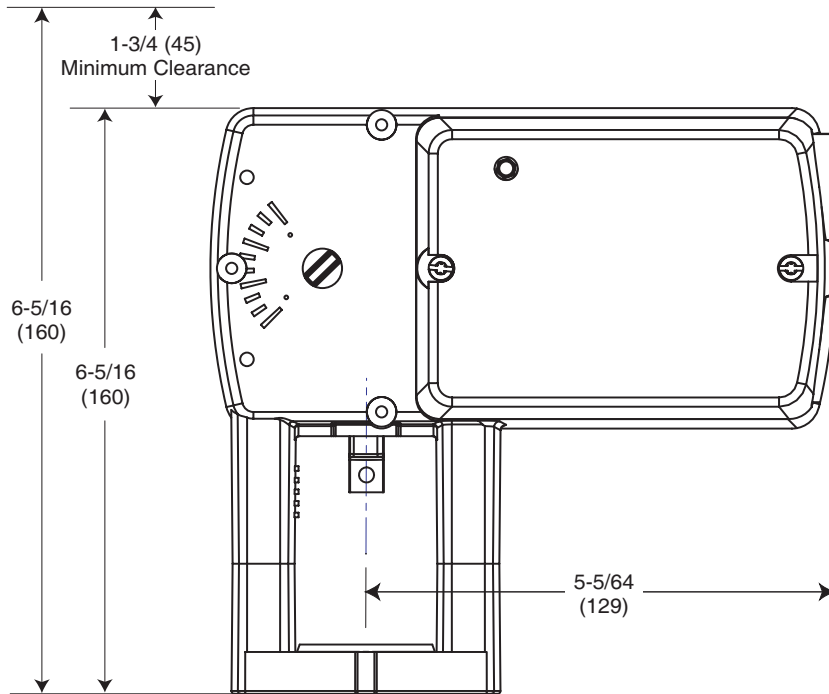

Dimensions shown are in inches (mm).

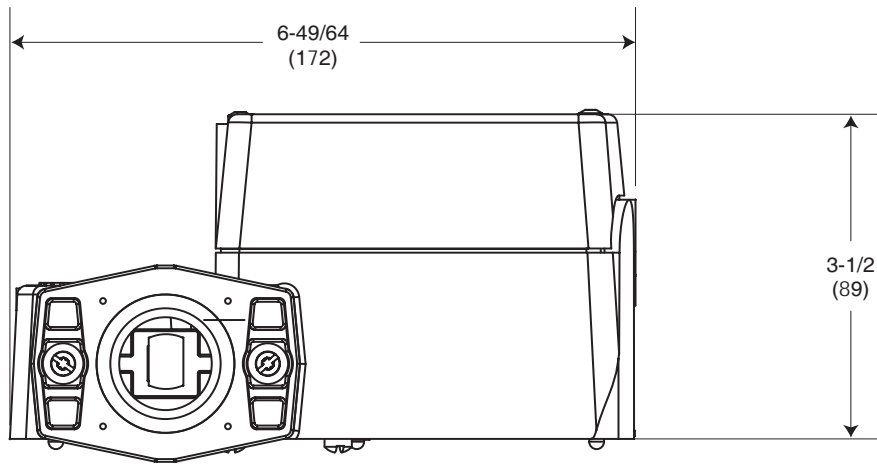

Figure-14 Mx51-710x Spring Return Valve Actuator Dimensions

© Copyright 2004 Invensys Building Systems, Inc. All rights reserved.

No part of this document may be photocopied or reproduced by any means, or translated to another language without prior written consent of Invensys.

All specifications are nominal and may change as design improvements are introduced. Invensys shall not be liable for damages resulting from misapplication or misuse of its products.

Invensys, DuraDrive, EconoDrive and DuraLynx are trademarks of Invensys plc and its subsidiaries and affiliates.

All other trademarks are the property of their respective owners.